

JUNE

HANDBOOK

OF

ELECTRO-THERAPEUTICS

BY

DR. WILHELM ERB,

PROFESSOR IN THE UNIVERSITY OF LEIPZIG

TRANSLATED BY

L. PUTZEL, M.D.,

NEUROLOGIST TO RANDALL'S ISLAND HOSPITAL, AND PHYSICIAN TO THE CLINIC FOR NERVOUS
DISEASES, BELLEVUE OUT-DOOR DEPARTMENT, ETC.

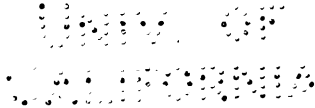

WITH THIRTY-NINE WOODCUTS

NEW YORK

WILLIAM WOOD & COMPANY

56 & 58 LAFAYETTE PLACE

1883

1-1

COPYRIGHT
WILLIAM WOOD & COMPANY
1888

TO THE
LIBRARY OF

TROW'S
PRINTING AND BOOKBINDING COMPANY
201-213 East Twelfth Street
NEW YORK

TABLE OF CONTENTS.

PART I.

PHYSICAL INTRODUCTION.

LECTURE I.

The Various Kinds of Currents—Contact Electricity; the Galvanic Current—Galvanic Circuits—Induction Electricity; the Faradic Current—The Ordinary Apparatus and Auxiliary Apparatus; Induction Apparatus and Galvanic Batteries pp. 1-10

LECTURE II.

Accessory Apparatus; Selector or Element Numerator—Polarity Changer—Galvanometer—Measurement of the Absolute Strength of the Current—Rheostat—Conducting Wires—Electrodes and their Various Forms—Electrical Table—Physical and Physiological Recognition of the Poles. pp. 11-18

LECTURE III.

Physical Laws of the Diffusion of the Current and their Application in Electro-therapeutics—Ohm's Law—Strength of Current—Resistance of Various Conductors: Resistance of the Animal Tissues, especially the Epidermis—Individual Differences in Man and their Consequences—Essential and Extra-essential Resistance; Conclusions therefrom Concerning the Construction of Apparatus—Density of the Current and its Laws—Practical Deductions for Various Electro-therapeutical Purposes—Electrolytic and Cataphoric Effects pp. 19-32

PART II.

PHYSIOLOGICAL INTRODUCTION.

LECTURE IV.

Effects of Electrical Currents on the Healthy Living Body—Electro-physiology of the Motor Nerves and the Muscles—Stimulant Action—Pflueger's Law of Contraction—Action of the Poles—Law of Contraction of the Motor Nerves in the Living Body—Polar Method of Examination—Law of Polar Contraction and its

Different Grades—Faradic and Galvanic Reaction of the Muscles—Electrotonic Phenomena—Electrotonus in the Living Body—Modifying and Exhilarating Effects. pp. 23-43

LECTURE V.

Electro-physiology of the Sensory Nerves and Nerves of Special Sense—Sensory Nerves of the Skin and their Law of Contraction—Sensory Nerves of the Muscles—Optic Nerve and Retina—Acoustic Nerve and the Nervous Auditory Apparatus—Nerves of Taste—Nerves of Smell. pp. 44-49

LECTURE VI.

Electro-physiology of the Secretory and Vasomotor Nerves—Cervical Sympathetic—Effect of Electrical Currents on the Skin—Electro-physiology of the Brain and Spinal Cord—Phenomena in Galvanization of the Brain and Spinal Cord in Man—Electro-physiology of the Organs of the Thorax and Abdomen—Electrolytic and Cataphoric Effects—Galvanic Introduction of Drugs into the Body—Remak's Catalytic Effects—Indirect Catalyses. pp. 50-57

PART III.

METHODS OF ELECTRICAL EXAMINATION AND ELECTRO-DIAGNOSIS.

LECTURE VII.

The Methods of Electrical Examination—Examination of the Motor Nerves and Muscles—Polar Method—General Rules—Method of Quantitative Examination of Irritability with the Faradic and Galvanic Currents—Method of the Qualitative Examination of Irritability—Examination of the Eye—Examination of the Auditory Apparatus—Galvanic Examination of Taste—Examination of Electro-cutaneous Sensibility—Electro-muscular Sensibility pp. 59-68

LECTURE VIII.

Pathological Changes of Electrical Irritability and their Diagnostic Significance—A. Electro-diagnosis of the Motor Nerves and Muscles—1. Increase—2. Diminution of Electrical Irritability—3. Degeneration Reaction—Description of De R—Its Course—Increased Mechanical Irritability pp. 69-78

LECTURE IX.

3. Degeneration Reaction (continued)—Its Relation to Degenerative Atrophy of the Motor Nerves and the Muscles. Their Description—Comparison of their Course with that of the De R.—Complete and Partial Degeneration Reaction—Occurrence of the De R.—Diagnostic Conclusions therefrom—Its Prognostic Significance—Special and Critical Remarks. pp. 79-88

LECTURE X.

4. **Rarer Quantitative and Qualitative Changes of Electrical Irritability:** *a.* Increase of Secondary Irritability (Convulsive Reaction)—*b.* Diminution of Secondary Irritability (Exhaustion Reaction)—*c.* Qualitative Changes in the Law of Contraction of Motor Nerves—*d.* Different Reaction of the Nerves to the Faradic and Galvanic Currents—*e.* Latent Period of Irritation in Faradic Stimulation of the Muscles—*f.* Diplegic Contractions—**B.** Electro-diagnosis of the Sensory Nerves—Anomalies of Farado-cutaneous and Farado-muscular Sensibility. pp. 89-94

LECTURE XI.

- C.** Electro-diagnosis of the Nerves of Special Sense. 1. Optic Nerve and Retina—2. Acoustic Nerve and Auditory Apparatus.—*a.* Simple Galvanic Hyperæsthesia—*b.* Hyperæsthesia with Change and Reversal of Normal Formula—*c.* Qualitative Anomalies without Hyperæsthesia—*d.* Torpor—3. Nerves of Taste—Electro-diagnosis of the Vasomotor Nerves, the Sympathetic, Pneumogastric, Central Nervous System, etc. pp. 95-102

PART IV.

GENERAL ELECTRO-THERAPEUTICS.

LECTURE XII.

- The Therapeutic Value of Electricity—Various Electro-therapeutic Theories—Empirical Standpoint—Available Effects of the Current and the Method Employed—Stimulating, Modifying (Refreshing), Catalytic Effects—Empirical Basis of the Latter—Direct and Indirect Catalysis—Therapeutic Galvanization of the Cervical Sympathetic—Reflex Effects of the Current.** pp. 103-112

LECTURE XIII.

- Methods of Therapeutic Applications in Local Diseases—Polar or Direction Method?—Advantages of the Polar Method—Empirical Methods—Influence upon the General Organism: 1. General Faradization (according to Beard and Rockwell); 2. General Galvanization; 3. Central Galvanization (Beard); 4. The Electrical Bath—Special Methods of Treatment: 1. Galvanic Treatment of Pressure and Painful Points; 2. Treatment with Feeble, Continuous, Galvanic Currents.** pp. 113-120

LECTURE XIV.

- General Principles and Special Technical Recommendations for Electrical Treatment—Treatment in Loco Morbi—Technique of the Localization of the Current—Local Faradization of the Motor Nerves and the Muscles—Plan of Treatment—Personal Acquaintance with the Effects of the Current—Choice of the Strength of the Current—Choice and Management of the Electrodes—Avoidance of Unnecessary Irritative Effects—Duration and Frequency of the Individual Applications—Entire Duration of Treatment** pp. 121-134

*PART V.***SPECIAL ELECTRO-THERAPEUTICS.**

INTRODUCTION..... pp. 135-136

I. DISEASES OF THE BRAIN, INCLUDING THE PSYCHOSES.**LECTURE XV.**

Introductory Remarks—Physiological, Experimental, and Theoretical Basis of Electro-therapeutics of the Brain—Therapeutical Facts—Collection of a Series of Individual Observations—Conclusions therefrom—Negative or Partial Curative Effects—The Forms of Disease in which Electro-therapeutic Success may, and those in which it may not, be expected..... pp. 137-147

LECTURE XVI.

Development of Electro-therapeutical Methods—Direct Treatment of the Brain: Catalytic and Vasomotor Effects and the Methods of Producing them—Stimulating and Modifying Effects—Technique of the Application of the Galvanic and Faradic Current in Cerebral Diseases—Indirect Treatment of the Brain: Galvanization of the Sympathetic—Reflex Effects from the Skin—Symptomatic Treatment—Electro-diagnosis in Cerebral Diseases—Electro-therapeutics of Individual Forms of Disease: Cerebral Neurasthenia; Insomnia; Hyperæmia; Anæmia; Hemorrhage; Cerebral Softening; Inflammation; Degeneration; Sclerosis, etc.; Bulbar Diseases—Incurable Cerebral Affections..... pp. 148-155

APPENDIX.**ELECTRO-THERAPEUTICS OF THE PSYCHOSES.****LECTURE XVII.**

Introduction—Investigations of Arndt and their Results—Short Résumé of the Literature—Available Effects of the Electrical Current—Rules and Methods of Electrical Treatment of Individual Forms of Psychoses—Treatment of Individual Symptoms..... pp. 156-159

II. DISEASES OF THE SPINAL CORD.**LECTURE XVIII.**

Introduction—Physiological and Theoretical Basis for the Electro-therapeutics of the Spinal Cord—Therapeutical Data; Selected Cases—Conclusions therefrom—Therapeutic Failures—Forms of Spinal Disease in which Electro-therapeutic Success may be expected—Methods and Technique of Electro-therapeutics of the Spinal Cord—Direct Treatment: Action of the Poles and the Direction of the

Current—Methods of Application in Circumscribed and Longitudinal Diseases—Indirect Treatment: From the Sympathetic; Combined Treatment of the Sympathetic—Reflex from the Integument—Diplegic Irritation—Treatment of Points of Pressure and Points Dououreux—Symptomatic Treatment..... pp. 160-169

LECTURE XIX.

Treatment of Individual Forms of Spinal Disease—Electro-diagnostic Preliminary Remarks—1. Spinal Meningitis—2. Meningeal Apoplexy—3. Functional Diseases of the Cord; Concussion, Spinal Irritation, Spinal Neurasthenia—4. Hemorrhages into the Spinal Cord: Severe Traumatic Lesions—5. Myelitis; Multiple Sclerosis—6. Tabes Dorsalis; Direct Galvanic Treatment; Treatment of the Painful Points; Farado-cutaneous Brush—7. Spastic Spinal Paralysis—8. Acute Anterior Poliomyelitis; Electrical Examination; Electrical Methods of Treatment—9. Subacute and Chronic Anterior Poliomyelitis—10. Progressive Muscular Atrophy; Condition of the Electrical Irritability; "Juvenile" Form; Method of Treatment; Amyotrophic Lateral Sclerosis—11. Acute Ascending Paralysis—12. Secondary Degeneration..... pp. 170-179

III. DISEASES OF THE PERIPHERAL NERVES.

LECTURE XX.

Introduction—Available Current Effects in Diseases of the Peripheral Nerves—Practical Experience: Cases—Technique and Methods of Electrical Treatment—Individual Forms of Disease: Neuritis; Hemorrhages and Circulatory Disorders; Slight Mechanical and Traumatic Lesions; Severe Traumatic Lesions; Degenerative Atrophy of the Nerves; Functional Disorders—Symptomatic Treatment—Electro-diagnostic Remarks..... pp. 180-186

IV. PARALYSIS AND ATROPHY.

LECTURE XXI.

Definition and Pathogenesis of Paralysis—Objects of Electro-therapeutics in Paralysis and the Methods of Effecting them: a. Removal of the Cause of Paralysis—b. Removal of Obstructions to Motor Conduction; Direct and Indirect Method; Utilization of Reflex Paths; Method of Application of the Faradic and Galvanic Currents for these Purposes—c. Relief of Finer or Grosser Nutritive Disturbances in the Motor Conducting Paths—d. Restoration of the Normal Condition of the Paralyzed Muscles—Treatment of Muscular Atrophy—Results of Electro-therapeutics in Paralysis—Electro-diagnosis of Paralysees—Practical Technical Remarks..... pp. 187-195

LECTURE XXII.

Electro-therapeutics of Individual Forms of Paralysis—1. Paralysis of the Ocular Muscles: Pathogenesis; Cases; Methods of Treatment; Results—2. Paralysis of the Muscles of Mastication—3. Paralysis of the Facial Nerve: Rheumatic

Form; its Situation and Nature; Condition of Electrical Excitability; Prognosis; Cases; Methods of Treatment; Results—Other Forms of Facial Paralysis—4. Paralysis of the Spinal Accessory Nerve—5. Paralysis of the Hypoglossal Nerve..... pp. 196-206

LECTURE XXIII.

Electro-therapeutics of Individual Forms of Paralysis (continued)—6. Paralysis of the Neck and Trunk: Pathogenesis; Cases; Methods of Treatment—7. Paralysis of the Upper Limbs: Pathogenesis; Symptomatology; Electro-diagnosis; Cases; Methods of Treatment; Results—8. Paralysis of the Lower Limbs: Pathogenesis and Individual Varieties; Electro-diagnosis; Cases; Methods of Treatment; Results..... pp. 206-218

LECTURE XXIV.

Electro-therapeutics of Individual Forms of Paralysis (conclusion)—9. Paralysis of the Velum Palati and Pharynx; Paralysis of Deglutition: Pathogenesis; Cases; Methods of Treatment—10. Paralysis of the Laryngeal Muscles; Paralysis of the Vocal Cords: Character and Methods of Treatment; Percutaneous and Endo-Laryngeal Application; Results—11. Paralysis of Respiration: Artificial Respiration; Rhythmical Faradization of the Phrenics—12. Diphtheritic Paralysis: Pathogenesis and Symptoms; Cases; Electrical Treatment; Galvanization of the Heart; Results—13. Lead Palsy and other Toxic Paralysis: Characteristics of Lead Palsy; Electrical Excitability; Situation and Character of the Disorder; Method of Treatment—14. Muscular Atrophy and Hypertrophy: Purely Muscular Atrophy; Atrophy in Articular Affections; Cases; Treatment; Muscular Hypertrophy; Congenital Myotonia..... pp. 219-233

V. PAIN, NEURALGIA AND NEURALGIFORM AFFECTIONS.

LECTURE XXV.

Introduction—Definition and Nature of Pain and Neuralgia—The Neuralgic Change—Electro-therapeutic Objects: Removal of the Abnormal Nutritive Conditions in the Nerves and of the Causes of the Neuralgic Change; the Actions of the Current Available for this Purpose; Cases—Electro-therapeutic Methods; Causal Treatment—Anti-neuralgic Methods: Direct Application of the Galvanic and the Faradic Current; Indirect, Electro-cutaneous Brush; Galvanic Treatment of Painful Points—General Plan of Treatment—Results..... pp. 234-244

LECTURE XXVI.

Individual Forms of Neuralgia: 1. Trigeminal Neuralgia; Practical Remarks Concerning the Individual Methods of Treatment—2. Cervico-occipital Neuralgia—3. Headache and Migraine; Various Methods of their Treatment—4. Cervico-brachial Neuralgia—5. Intercostal Neuralgia—6. Neuralgia of the Lumbar Plexus—7. Sciatica; Various Methods of Galvanic and Faradic Treatment; Neuralgia of the Urinary and Sexual Organs; Coccygodynia—8. Neuralgias of the Joints—9. Visceral Neuralgias: Neuralgia of the Pharynx and Larynx; Angina Pectoris, Gastralgia; Enteralgia; Lead Colic; Neuralgia in the Distribution of the Pelvic Nerves..... pp. 245-258

VI. SPASM AND CONTRACTURE.

LECTURE XXVII.

Introduction: Character and Pathogenesis of Spasms; the Spastic Change—The Electrical Irritability—Electro-therapeutic Objects: Relief of the Direct Motor Irritation; Removal of Reflex Stimuli; Production of Vigorous Inhibition; Cases—Electro-therapeutic Methods; Causal Treatment; Direct Antispastic Treatment and its Methods; Galvanic and Faradic; General Plan of Treatment; Results—Individual Forms of Spasm: Spasms of the Muscles of Mastication; Mimic Facial Spasm; Blepharospasm; Spasm in the Distribution of the Spinal Accessory and in the Neck; Spasm in the Muscles of the Trunk; Respiratory Spasm, Singultus, etc.; Spasms in the Upper and Lower Limbs pp. 259-272

VII. ANÆSTHESIA.

LECTURE XXVIII.

Character and Pathogenesis of Anæsthesia—Electrical Examination—Objects of Electro-therapeutics; Cases—Methods of Electrical Treatment: Causal Treatment; Direct Treatment of Anæsthesia; Methods with the Faradic and Galvanic Currents; Relief of Secondary Trophic Disturbances; Results—Individual Forms: Anæsthesia of the Trigemini, the Pharynx and Larynx; Vasomotor Anæsthesia; Hysterical Anæsthesia; Ataxic Anæsthesia. pp. 273-279

VIII. DISEASES OF THE CERVICAL SYMPATHETIC.—VASOMOTOR, TROPHIC, AND ALLIED NEUROSES.

LECTURE XXIX.

Diseases of the Cervical Sympathetic; Occurrence and Symptoms; Irritation and Paralysis; Methods of Electrical Treatment—Vasomotor Neuroses—Cutaneous Angioneuroses—Symptoms of Spasm and Paralysis of the Vasomotor Neuroses; Methods of Electrical Treatment—Intermittent Dropsy of the Joints—Vasomotor Trophic Neuroses of the Integument—Anomalies of the Secretion of Perspiration—Progressive Facial Hemiatrophy; Probable Site; Methods of Electrical Treatment—Scleroderma; Method of Treatment. pp. 280-287

IX. GENERAL NEUROSES.—CENTRAL AND OTHER FUNCTIONAL NEUROSES.

LECTURE XXX.

Theory of the Functional Neuroses—Electro-therapeutic Objects: Removal of the Local Nutritive Disturbances; Influence upon the Entire Nervous System and the Entire Organism; Removal of Definite Causes of Disease; Treatment of Individual Symptoms—1. Neurasthenia: Various Forms; Nature of the Disease; Methods

of Treatment; Results—2. Hypochondriasis—3. Hysteria; its Nature, Object, and Methods of Electrical Treatment—4. Epilepsy—5. Co-ordinate Professional Hyperkineses; Writer's Spasm; Various Forms; Methods of Treatment—6. Chorea Magna. pp. 288-297

LECTURE XXXI.

7. Chorea Minor: Its Situation and Character; Electrical Treatment—8. Tetanus: Methods of Treatment—9. Tetany: Its Characteristics: Electrical Excitability; Character and Location of the Disease; Electrical Treatment—10. Catalepsy—11. Tremor—12. Paralysis Agitans—13. Athetosis—14. Basedow's Disease: Symptoms and Location of the Disease; Methods of Electrical Treatment—15. Vertigo—16. Diabetes Mellitus and Insipidus. pp. 298-306

X. DISEASES OF THE ORGANS OF SPECIAL SENSE.

LECTURE XXXII.

Introduction—Diseases of the Visual Apparatus: Their Electro-diagnosis—Diseases of the Lids, Conjunctiva, Cornea, Iris, Lens, Vitreous Body, Choroid—Diseases of the Retina and Optic Nerve: Retinitis Pigmentosa; Papillitis and Papillo-retinitis; Optic Neuritis; Cases; Method of Treatment—Atrophy of the Optic Nerve: Tabetic and Genuine Atrophy; Cases; Treatment— Amaurosis without Anatomical Lesion—Hemianopsia—Diseases of the Ocular Muscles: Insufficiency of the Interni; Accommodative Asthenopia; Mydriasis; Nystagmus pp. 306-315

LECTURE XXXIII.

Diseases of the Auditory Apparatus—Introduction—Dryness of the Auditory Canal—Opacities of the Membrane—Diseases of the Auditory Nervous Apparatus: Nervous Tinnitus Aurium; Its Relations to Galvanic Reaction; Electro-diagnosis; Therapeutic Indications; Determination of the Method of Treatment; Cases; Principles of Treatment; Special Procedures in Individual Cases; General Rules and Technical Remarks; Results—Nervous Deafness; Cases; Method of Treatment—Deaf-mutism—Menière's Disease—Neuroses of the Gustatory Nerves; Ageusia—Neuroses of the Olfactory Nerves: Anosmia and its Treatment . . . pp. 316-326

XI. DISEASES OF THE ORGANS OF LOCOMOTION, THE GLANDS, THE THORACIC VISCERA, AND THE DIGESTIVE APPARATUS.

LECTURE XXXIV.

Diseases of the Organs of Locomotion: Muscular Rheumatism; its Varieties and Character; Various Methods of Treatment; Results—Articular Affections; Introduction—Acute Inflammations of the Joints: Traumatic and Other Forms; Rheumatic Polyarthritis; Chronic Inflammations of the Joints: 1. Monoarticular Chronic Articular Rheumatism; 2. Polyarticular Chronic Articular Rheumatism; 3. Arthritis Deformans; 4. Stiffness and Ankylosis of the Joints—Diseases of the Glandular Organs; Tumors of the Lymphatic Glands—Scrofula—Splenic Tumors—Diseases of the Thoracic Viscera—Nervous Asthma—Nervous Palpitation of the Heart—Debility and Irregularity of the Heart. . . . pp. 327-335

LECTURE XXXV.

Diseases of the Digestive Organs: Neuroses of the Oesophagus—Diseases of the Stomach: Nervous Vomiting; Cardialgia; Nervous Dyspepsia; Methods of Electrical Treatment; Atony and Dilatation of the Stomach—Diseases of the Intestines: Nervous Enteropathy; Enteralgia; Atony and Paralysis of the Muscular Coat of the Intestines: 1. Occlusion of the Intestines by Atonic Accumulation of Fæces; Pathology; Cases; Methods of Electrical Treatment; Invagination of the Intestines; 2. Chronic Constipation from Atony of the Intestines; Cases; Percutaneous Faradization; Recto-abdominal Faradization; Galvano-faradization; 3. Prolapsus Ani; Paresis of the Sphincter Ani; Ascites; its Faradic Treatment. pp. 336-344

XII. DISEASES OF THE URINARY AND SEXUAL ORGANS.

LECTURE XXXVI.

Diseases of the Bladder. Introduction. Vesical Spasm; Causal and Direct Treatment—Paralysis of the Bladder: Various Forms; Pathogenesis; Causal and Direct Treatment; Percutaneous and Internal Applications; Galvanization of the Lumbar Cord—Nocturnal Enuresis: Its Nature; Methods of Treatment—Diseases of the Male Sexual Organs: Inflammation and Hypertrophy of the Prostate; Orchitis—Functional Disorders: Impotence; Pollutions; Spermatorrhœa; Aspermatism; Pathogenesis; Causal and Direct Treatment—Diseases of the Female Sexual Organs—Introduction—Ovarian Hyperæsthesia—Disturbances of Menstruation: Amenorrhœa; Dysmenorrhœa; Menorrhagia—Chronic Metritis—Changes in the Position of the Uterus—Deficient Secretion of Milk—Concluding Remarks—Contra-indications to the Employment of Electricity—Condition of the Circulatory Organs and Mode of Reaction of the Nervous System. pp. 345-357

INDEX. pp. 359-366

EXPLANATION OF THE ABBREVIATIONS USED IN THE TEXT

An = Anode, positive pole.

Ca = Cathode, negative pole.

Cl = Closure.

O = Opening.

D = Duration, the period during which the circuit is closed.

C = Contraction.

Ca Cl C = Cathodal closure contraction.

An O C = Anodal opening contraction.

Ca Cl Te = Cathodal closure tetanus = **Ca D C >**, cathodal duration contraction.

C R = Resistance to conduction.

D N = Deflection of the needle.

De R = Degeneration reaction.

ELECTRO-THERAPEUTICS.

PART I.

PHYSICAL INTRODUCTION.

LECTURE I.

The Various Kinds of Currents—Contact Electricity; the Galvanic Current—Galvanic Circuits—Induction Electricity; the Faradic Current—The Ordinary Apparatus and Auxiliary Apparatus; Induction Apparatus and Galvanic Batteries.

I MAY assume without a doubt that you are acquainted with the doctrine of the physics of electricity in all its main features. This, at all events, forms the only reliable foundation of electro-therapeutics, the basis for an assured employment of this therapeutic agent for diagnostic as well as therapeutic purposes. I cannot, therefore, recommend too strongly to you a careful attention to this subject and its frequent recapitulation. If you desire to become good electro-theraputists, you must completely master it, so far as it comes in question for our especial purposes. The attainment of this goal will be rendered considerably easier for you by the excellent little works of J. Rosenthal, Fick, Zech, v. Beetz, and de Watteville.

At the same time I neither can nor will omit to give a short description of those features which are absolutely necessary in order to understand what is to come hereafter; but this can be nothing more than a rapid sketch, which you should fill in by independent study.

As is well known, electricity appears in various modifications, which are dependent on the method of their production and on the arrangement of the current-producing apparatus.

At the present time, we employ almost exclusively, for therapeutic purposes, the so-called electrical current. For a long time past, and even to-day, numerous therapeutic trials have been made with frictional electricity, the so-called tension or static electricity, obtained from frictional

electric machines and the so-called induction machines ; but these experiments—even the latest ones made in Paris—have furnished no very encouraging results, and static electricity has still to conquer a secure place in electro-therapeutics. In the following disquisition we shall therefore not refer to this form of electricity—for which, however, the same laws, in general, hold good as for the electrical current.

Electrical currents, as is well known, may be produced by very different substances ; in electro-therapeutics we employ almost exclusively, at the present time : 1, *galvanic currents* produced by *contact* (constant, continuous battery currents) ; and 2, the so-called *faradic currents* produced by induction (induced, interrupted, induction currents). The currents produced by the newer, powerful electrical machines, which are used chiefly for industrial purposes, and which are, perhaps, destined to play a

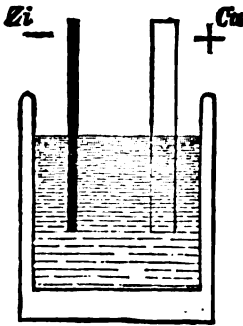

FIG. 1.

FIG. 1.—A simple galvanic element ; zinc (Zn) and carbon or copper, (Cu) immersed in a fluid (solution of acid or salts).

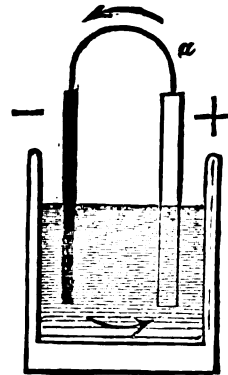

FIG. 2.

FIG. 2.—A simple galvanic element, closed by the circuit of closure (a) ; the direction of the positive current is indicated by the arrow.

prominent part in electro-therapeutics, may be left unnoticed for the present.

Contact Electricity.—The most simple scheme for the production of contact currents—entirely apart from the still unsettled physical theory of galvanism, concerning which we need not enter here further in detail—is the following : If two different metals (either copper and zinc, or carbon and zinc) in the shape of plates are placed parallel to one another, but without coming in contact, in a fluid, a solution of a salt or acid (as in Fig. 1), a separation of the electricity in the metals will be produced by their contact with the fluid, so that all the positive electricity accumulates, under a certain tension, on the one metal, all the negative electricity on the other.

This tension varies greatly, according to the quality of the metals and the fluid employed. The various metals can be arranged in a series (ten-

sion series), in which the one situated at one end becomes most positively electrical from contact with a certain fluid, that at the other end most intensely negatively electrical.

Such a simple combination—two metals in a fluid—is called an *open chain*, or an open, simple element. If the free ends of the metals are connected with one another by a conducting body, as a metal wire (Fig. 2), the electrical tensions produced upon the two metals are equalized through this wire, which is termed the “circuit of closure,” inasmuch as the electricity flows from one metal to the other. We then have a closed element in which an electrical current is flowing.

The equalization of the tension does not cease with the closure of the chain, but the contact of the metals with the fluid (or their chemical action upon one another) causes a continuance of the separation of the electricity, a constantly recurring tension, by means of which—so long as

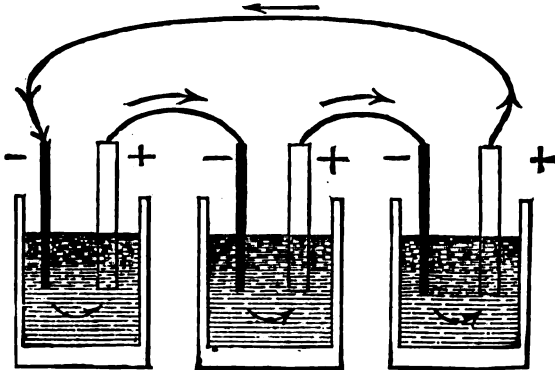

FIG. 3.—A compound chain. Three elements arranged “behind one another.” The direction of the current is indicated by the arrows.

metals and fluid are still present—a constant flow of electricity is produced in the circuit of closure and throughout the entire chain.

This power of permanently maintaining and constantly reproducing a certain difference in the electrical tension, is called the electro-motor power of such a combination. Its amount depends alone upon the quality of the metals and fluids employed in the combination. In any individual case, the greater the difference of tension between the two metals, the greater is the amount of electricity produced by the combination, and thus, also, *ceteris paribus*, the greater will be the strength of the current produced.

If a number of these simple elements are placed alongside one another, and the metal of one connected with the differently named metal of the next (Fig. 3), the tensions produced in all the individual elements will be aggregated, and the sum of these tensions will appear at the terminal points of such a compound chain. It produces a corresponding increase

of the strength of the current in the "circuit of closure," which connects the free end of the metal of the last element, which has become positive, with that of the first element, which has become negative.

This form of connection of the elements is called an arrangement "behind one another." In the electro-therapeutics of internal diseases, we make exclusive use of such elements arranged "behind one another" (for reasons which will be made evident later), and these may be collected in any number desired into so-called "batteries;" we shall therefore, once for all, discuss such elements and batteries alone.

In a compound element of this character, the "circuit of closure" passes from the first to the last element; the current flowing in it has a

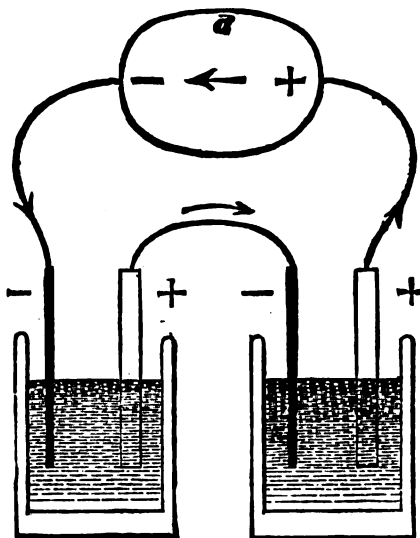

FIG. 4.—Schematic representation of the introduction of the human body (a) into the circuit of closure of a galvanic chain. + is the anode, — the cathode.

definite strength and direction, and naturally runs in an opposite direction in the element itself from that in the "circuit of closure"—in the "circuit of closure" from the carbon to the zinc, within the chain itself from the zinc to the carbon. It has been agreed to call that end of the element from which the positive current passes into the "circuit of closure," the positive pole or the anode, the opposite end, where the positive current again enters the chain, i.e., leaves the "circuit of closure," the negative pole, or cathode.

You may now divide the "circuit of closure"—imagined, in its simplest form, as a simple conducting wire—and insert any other conducting body between the two ends

(a, Fig. 4). The current will then pass through this conducting body, according to the laws which govern the latter. This is also true when the human body or individual parts of it are inserted in such a "circuit of closure." The points of entrance and exit of the current and its diffusion in the body then depend upon the situations at which both halves of the "circuit of closure" are applied, upon the resistance of the body, etc. These factors all depend upon laws which I shall soon explain to you. That portion of the "circuit of closure" which conveys the positive current to the human body is called the positive pole or anode (An); the other part, by which the positive current escapes from the body, the negative pole or cathode (Ca). The portions of the "circuit of closure" giving ingress and egress to the current, and which, for practical purposes, may

be given various forms at the points of contact with the human body, are called electrodes.

The essence of electro-therapeutics consists simply in the fact that the human body—either as a whole, or generally only certain parts of it—is introduced in a definite manner into the “circuit of closure” of a galvanic (or some other electrical) current; in other words, the current is conveyed by means of the electrode to the body or its parts, and allowed to act upon it, with a certain intensity, for a variable period, with or without interruptions. It is very evident that an endless variety of applications may be produced in this manner, and that the art of the electro-therapeutist consists essentially in the choice of the proper method of application in an individual case of disease.

The chief requisite of all galvanic elements employed for electro-therapeutic purposes is that they should furnish a constant current of a strength corresponding to the relations of the human body as regards conduction, and which may be readily conveyed to the body by suitable electrodes. At a later period I will briefly refer to the other necessary auxiliary apparatus.

Induction Electricity.—Under this term we may discuss the induction currents produced by magnets as well as by galvanic currents, since essentially they amount to the same thing.

Electrical currents may be produced by the action of magnets upon closed conductors; if a magnet is rapidly approximated to such a closed conductor—for example, a wire wound upon a cylinder, a wire spiral, the ends of which are connected with one another—an electrical current develops in the spiral during this approximation: if the magnet is rapidly removed, a current again develops in the spiral, but in the opposite direction from the first. These currents are so much stronger, the stronger the magnet, the more rapid its approximation and removal, and the greater the number of turns in the wire spiral. If the human body is introduced between both ends of the wire spiral, these currents will pass through the body and may thus be employed physiologically and therapeutically. Upon this principle depends the construction of the so-called magneto-electrical or rotation apparatus, in which, by a suitable arrangement, a magnet is very rapidly and frequently approximated and removed from a wire spiral, by means of which a large series of rapidly following currents develop, directed alternately in opposite directions; these may exercise a very vigorous effect upon the human body. The rotatory apparatus have recently been displaced by the so-called induction apparatus, because their employment was attended with much inconvenience. I will therefore spare you further details concerning their construction.

Perfectly analogous electrical currents may be produced with great readiness by galvanic currents, by means of induction. If a wire spiral, through which a galvanic current is following, is rapidly approximated to

a similar closed wire spiral, an electrical current develops in the latter during this approximation, and is directed in the opposite direction to that flowing through the former ; if the first spiral is now removed with equal rapidity, a current again develops in the second spiral, which now flows in the same direction as that in the first. This is also the case when both spirals are fixed at a certain distance from one another ; and if a galvanic current now develops in the first—the primary—spiral, it is as if it were very rapidly brought from an infinite distance into close proximity, and an induced current will develop accordingly in the other—the secondary—spiral, and likewise when the galvanic current again disappears in the primary spiral. Such a rapid development and disappearance of the current can be produced readily by alternate opening and closure of the primary current in the primary spiral. At each closure, a current develops in the secondary spiral in a direction opposite to the primary current ; at each opening a current develops in the same direction. These “induced” currents are so much stronger, the stronger the primary current, the greater the number of turns in the primary as well as the secondary spirals, and the closer both spirals are to one another—strongest, therefore, when one is pushed entirely over the other.

If the opening and closure of the primary current follow rapidly and constantly, a continuous series of rapidly following currents alternately directed in opposite directions occur in the secondary spiral ; these are the so-called induced or induction currents, or faradic currents, as they are now called almost universally by electro-therapeutists. If the human body is inserted in the secondary spiral, these faradic currents will pass through the body, and can produce their physiological and therapeutical effects.

All currents produced in this manner have an extremely short duration ; they are currents of almost momentary duration. The apparatus constructed in the most varied forms for their production are the so-called induction apparatus. Their ordinary construction gives rise to the circumstance that the induced currents (of the secondary spiral) produced by the closure and opening of the primary current are of unequal strengths : the current developing during closure (closure induction current) is delayed and weakened by an extra current (to which we shall refer again), developing at the same time in the primary spiral, while at the opening of the primary current this extra current does not develop usually, and consequently cannot modify the secondary opening induction current. The stronger opening current is always followed, therefore, by a weaker closure current in the secondary spiral. The difference between both is quite considerable, as you can readily prove by holding both ends of the secondary spiral in the hands, and making single openings and closures of the primary current ; at each opening you will experience a very severe shock, at each closure a very feeble shock or none. By a suitable arrangement

applied to the apparatus, this difference may be almost entirely compensated; usually this is not done in the apparatus employed for therapeutical purposes.

In the application of these currents to the human body, the opening current is so predominant that it may be taken into consideration almost exclusively, and we are thus justified, to a certain extent, in determining the direction of the current, and choosing the name of the pole according to it. In the employment of secondary induction currents, we may indeed speak of the anode and cathode, inasmuch as we mean that this is true of the opening current alone; but we should not forget that each electrode is alternately anode and cathode in rapid succession.

The action of the induced current may be considerably intensified by combining with it the action of a magnet. If a soft iron rod or a bundle of iron wires be pushed into the primary cylinder, it becomes magnetic on closure of the current, demagnetized on opening it, and the induction effect, which corresponds to that of a magnet rapidly approaching from an infinite distance and disappearing with equal rapidity, is added to that of the primary coil. In the majority of our induction apparatus these soft iron wires are introduced therefore within the primary coil.

In all these apparatus you will also find a small arrangement which automatically produces interruption (closure and opening) of the primary current, and which is conveyed from an external source—usually one or two galvanic elements—to the primary spiral; the contact which secures the closure of the current is broken and restored with extremely rapid alternation, by means of an armature which is made to vibrate through the action of a magnet. The principle of this arrangement is always the same; the method of its construction may be very different.

I must here refer to another point, viz.: that in the primary spiral itself induction effects and currents develop, inasmuch as the individual coils of such a spiral produce induction in one another. The currents developing on closure need not usually be considered, but, on the other hand, the induction current developing at the opening of the primary current may be readily detected by suitable mechanism, and employed for therapeutical purposes; this is the so-called extra current. It is an induced current, but develops in the primary spiral; it is also called the primary faradic current, that developing in the secondary spiral being termed the secondary faradic current.

The fundamental principle of the induction apparatus therefore consists in this, that by means of frequent interruptions of a galvanic current passing through the primary spiral, currents are induced in the secondary as well as in the primary spiral, and these may be conveyed to the human body by suitable arrangements.

A gradation of the strength of these currents may be secured by pushing one spiral over the other, by pushing in the soft iron wire, etc. It

should always be kept in mind in this connection that induced currents consist of a large number of currents of momentary duration, following one another in rapid succession; entirely different, therefore, from the galvanic current, which flows constantly in the same direction.

In the consideration of the apparatus and accessory apparatus in common use, I shall merely give a short description, pertaining chiefly to the principles involved. I desire simply to formulate the demands which must be made upon the apparatus, and which can be fulfilled in various ways, and I will then describe, somewhat more closely, the most indispensable accessory apparatus.

The first demand to be made upon an induction apparatus is that the spirals be sufficiently large to produce the necessary strength of current, and that the length and thickness of the wires in the primary and secondary coils present a proper relation to one another. (It has always appeared to me that secondary coils of very thin wire are less suitable because they produce currents which are decidedly more painful.) Convenient arrangements for the conduction of the secondary and primary induction currents must be present, and the possibility of properly graduating the strength of the current. Finally, the automatic interruptor should have a good and reliable movement; the galvanic element necessary to work the instrument must be sufficiently strong and constant, and the number of coils and the thickness of the wire in the primary spiral must be chosen correspondingly.

For all scientific investigations, for exact work, for permanent apparatus in the home of the physician and specialist, the well known Dubois-Reymond's sliding apparatus are best adapted.

For other purposes, especially for outside practice, the so-called portable induction apparatus are best suited. The coils may be placed either horizontally or vertically, are also provided with an arrangement to graduate the current, not infrequently with scales, upon which these gradations can be read off.

The industry of manufacturers and the inventive spirit of many electrotherapeutists have led to the construction, also, of numerous small, so-called pocket induction apparatus, which are characterized by small size and weight, usually by ready applicability; they may be very useful in many cases in practice, but are not suited for more exact diagnostic and scientific investigations, and usually lose their power after prolonged use.

In the construction of galvanic batteries all possible galvanic elements may be employed, provided they are well made and in good condition—from the older Daniell's, Grove's, Bunsen's elements to the newer ones of Stoehrer, Siemens-Halske, Pincus, Leclanché, Trouvé, Muirhead, Smee, etc. For practical purposes, with respect to cheapness and especially with reference to convenience, filling and cleaning the elements, it will naturally be necessary for you to make a choice.

To one point I cannot omit calling your attention at the present time, viz., that no great importance is to be attached, in practical electro-therapeutics, to the greatest possible and absolute constancy of the elements. The requirement of really constant elements, which is sometimes maintained by "exact" electro-therapeutists or brought into prominence by the instrument makers, is simply naïve when compared with the real circumstances. A constancy of the elements, such as is required in our applications to each individual, lasting three, five, or at the most ten minutes, is secured even by the poorest construction; and, on the other hand, even in the employment of the most constant elements during ordinary therapeutical applications to the living body, so many factors are introduced which cause variations in the strength of the current—for example, increasing conductivity of the epidermis and skin on account of the moisture of the latter; duration of the current; change of resistance from increased or diminished temperature, from the larger or smaller amount of fluid with which the electrodes are moistened; change in the pressure with which they are applied; polarization at the electrodes, perhaps also within the tissues, etc.—that the supposed constancy of the current is purely illusory. The constancy of the elements is only important with reference to the duration and reliability of the battery as a whole, but it is not by any means a necessary requisite for our therapeutical purposes and may be fully compensated by other advantages, presented by many inconstant elements.

The most necessary qualities required in a galvanic battery by the practical physician are: cheapness, readiness of use and ease in keeping it in order, a certain durability of the elements, a sufficient number of the latter, the possibility of removing and reinserting them at any moment, a suitable and easy method of introducing and employing any number of elements.

We now possess a large number of batteries composed of the most various elements (Stoehrer, Leclanché, Siemens-Halske, Daniells, Trouvé, etc.) which leave scarcely anything to be desired.

One difficulty still remains: a transportable battery which is readily conveyed without any inconvenience and at the same time remains in working order, so that the practitioner can carry it in his carriage, still remains to be constructed. Great progress has been made in this direction, and there are now numerous batteries which are readily transportable. But they still present many inconveniences. You will be told in one of the next lectures that the elements employed for therapeutical purposes in human beings may be as small as desired without losing their electro-motor power. But this small size nevertheless has its practical limits on account of the slight durability of many of these elements, the danger of rapid evaporation and the necessity of frequent renewal of the fluid, on account of the frequent change necessary in the metal of the ele-

ments, etc. It would, however, be very interesting to investigate whether elements of varying size but of the same construction, or elements of varying construction (Bunsen and Leclanché, Daniell and Pincus), can produce different physiological and therapeutical effects. From a purely physical standpoint, this cannot be readily accepted, but the remarks and observations of some electro-therapeutists indicate such a possibility.

So far as my observation goes, the batteries constructed by Stoehrer, and which have been subjected to innumerable imitations, appear to me to be the most serviceable. For the specialist, for hospitals, etc., the large batteries of Siemens-Halske or Leclanché elements, or even of Meidinger elements, may be recommended, but they require thorough repair from time to time, and it is more difficult to keep them in order.

LECTURE II.

Accessory Apparatus: Selector or Element Numerator—Polarity Changer—Galvanometer—Measurement of the Absolute Strength of the Current—Rheostat—Conducting Wires—Electrodes and their Various Forms—Electrical Table.—Physical and Physiological Recognition of the Poles.

THE proper practical application of the apparatus above described requires a number of accessory apparatus, upon the proper construction of which depends in good part the ease and exactness of the application of the current for diagnostic and therapeutic purposes.

Under the term selector, or better, element numerator (according to Zech) is meant a small apparatus which should not be absent in any galvanic battery and which enables us to include or exclude from the circuit any number of elements desired—if possible without interruption of the closed current. This is effected by a number of contacts corresponding to the number of elements, and which may be connected with the conducting wires by the most various methods; either by means of contact springs which are fixed to a sliding movement, to be moved to and fro (Stöhrer), or to a revolving disc, and are so arranged that the last contact is not broken until the next has been reached; or by means of two plugs, one of which is not removed until the other has already been placed in the next. The most perfect selector is that which enables us to include one additional element at a time in the circuit; this is frequently only possible for the smaller number of elements, for the larger ones each three, five, or ten elements.

A very important accessory apparatus, which is indispensable for all more exact investigations, is the polarity changer. This little apparatus is introduced into the circuit for the purpose of changing the direction of the current at pleasure. It must also be so arranged that it permits simple opening and closure of the current in any direction of the latter, and also reversal of the direction of the current with readiness. The very practical polarity changer, which is now in almost general use, has the construction shown schematically in Fig. 5.

Upon the periphery of a movable gutta-percha disc two metal strips are fastened in such a manner that a distance of 1 to 1½ ctm. is left between their free ends. Four metallic contacts conduct the current to and fro; 1 and 2 are connected with the battery (Anode +, Cathode -), 3 and 4 con-

vey the current farther through the circuit. The metal strips mentioned secure the connection between two contacts—in position I., between 1 and 3 on the one hand, and 2 and 4 on the other. In this position of the disc, which is revolved by the lever *a*, the current passes from 1 to 3, and 3 is therefore the anode; it returns from the circuit, from the human body, to 4 and then passes to 2; 4 is therefore the cathode; the current passes in the circuit of closure from 3 to 4.

If the lever *a* is turned a quarter of a circle so that it assumes position III., you will see that this direction is reversed; contact 1 is now connected with 4, contact 2 with 3; 4 has become the anode, 3 the cathode; the current passes in the circuit of closure and the body from 4 to 3; you have thus produced a "reversal of the direction of the current."

If the lever *a* is only turned 45°, so that it assumes position II., two of the contact springs touch the free space between the two metal strips, *i. e.*,

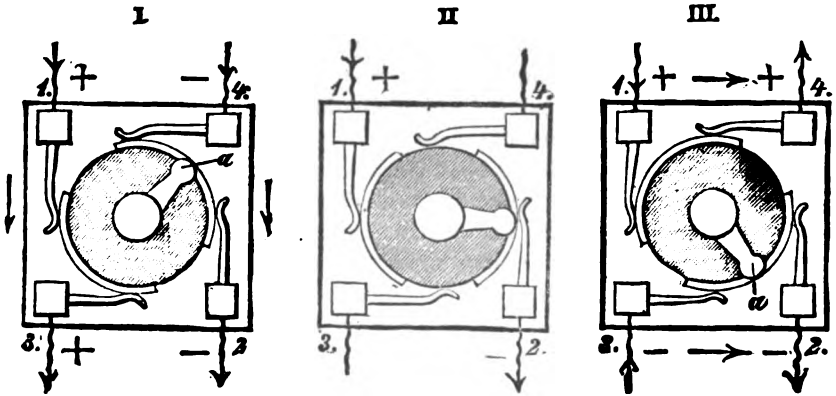

FIG. 5.—Schematic representation of the polarity changer in three different positions of the hard rubber disc, which may be revolved by the lever *a*. Contacts 1 and 2 are connected with the battery, 3 and 4 conduct the current into the circuit of closure. In I., the anode is situated at 3, in III. at 4, and the direction of the current in the circuit of closure is accordingly reversed. In II., the circuit is open.

the current is open. You may then, at pleasure, close it in one or the other direction and again open it, without reversing the current; you may at will convert each of the contacts 3 and 4 into the anode or the cathode, and if the electrodes in connection with them are applied to a certain part of the body, you may there secure the action of the cathode or the anode, make a cathodal closure and opening, or an anodal closure and opening. Or you may, at the same locality, reverse from the anode to the cathode or vice versa.

Brenner's modification consists in the introduction of an intervening piece, which fills the free space between the two metal strips with the exception of a small slit, and thus permits very rapid reversal of the current, which is requisite for many diagnostic purposes.

The polarity changer is an indispensable apparatus for exact electrical

examination, for the making of repeated closures and openings of the current in both directions, and for reversals of the current. In many batteries you will still find polarity changers which merely permit reversal of the current, but not simple opening and closure of the current; these are worthless or, at least, absolutely useless for electro-diagnostic examinations.

A good galvanometer is no less indispensable for all accurate investigations and, I may also add, for the ordinary operations of electro-therapeutics. Formerly it was only employed to indicate that the current was really passing. More recently it has been recognized that the galvanometer is very useful and even necessary in measuring the strength of the current which really comes into play, in diagnostic examinations as well as in the therapeutical applications. I was the first to declare it incontrovertible that, in quantitative electrical examinations of irritability, the determination of the strength of the current employed can be made by means of the galvanometer alone, as its determination in the manner formerly in vogue, according to the number of elements employed or the resistance of the rheostat introduced into the circuit, is entirely insufficient and faulty. At my suggestion Hirschmann in Berlin has constructed a galvanometer (a vertical galvanometer, according to the principle of the multiplier) which meets all ordinary requirements, possesses four grades of sensitiveness, and thus permits measurement of the most varying strengths of the current and is very useful in diagnostic examinations. This has been very generally accepted, but it possesses the disadvantage that the figures found by its means can only be compared with each other in each individual instrument, since the movements of the needle vary greatly according to the sensitiveness of the instrument. In addition, the strength of the current is only proportional to the angle of deflection when the latter is small, while the strength of the current increases much more rapidly than the angle of deflection when this is great.

The attempt has been made recently to construct a galvanometer which will indicate the absolute strength of the current. These galvanometers are graduated empirically in such a manner that the strength of the current is expressed in definite, generally accepted units, so that we can simply read off: this is a current of six, or ten, or twenty, or twenty-five "units of the strength of the current." On account of the increasing resistance with the increased deflection of the needle, it is evident that the divisions of the scale must gradually come in closer proximity. At present authors are still at variance with regard to the unit of strength to be accepted—whether the "milliveber" proposed in England, or the units employed in Germany, and which differ slightly from the English.

The adoption of the same scale would be attended with very great advantages; we would then be able to express the strength of the current in simple numbers (for example, a current of five, ten, twenty millivebers, etc.), to mention accurately the strength of the current in examining the

irritability of nerve-structures, to compare the statements of others with our own figures, to control accurately the strength of the current in therapeutics, and thus regulate the dose of electricity as of all other medicinal agents.

Easy as this may appear to some, there are still many technical difficulties which must be overcome in the construction of such galvanometers. A physiological obstacle to the general applicability of absolute measures of the strength of the electrical current appears to me to be much more important; this is the significance of the density of the current, which is entirely independent of its absolute strength, with regard to its physiological and therapeutical action. Every experienced electro-therapeutist knows that the effect of a definite strength of current, if the electrode applied to the nerve has a surface of contact of one square centimetre, is entirely different from that produced if the surface of contact measures twenty square centimetres. The most exact statements must be made with regard to the method of application, the form and size of the electrodes, and their exact points of application, or the statement of the absolute strength of the current will have no value.

Numerous attempts have been made to introduce the so-called rheostat into electro-therapeutics, in order to make a delicate and uniform gradation of the strength of the current in the circuit. The attempt was made to attain this end, partly by introducing graduated resistances into the circuit,—usually columns of fluid such as water, solutions of salt, and the like (fluid rheostats)—partly by introducing into the auxiliary circuit of the main circuit variable resistances, with the increase in which the strength of the current in the circuit increases, with whose diminution the strength of current in the main circuit diminishes (Brenner's rheostat). All these instruments fulfil their purpose in a very defective manner. The fluid rheostats soon become uncertain on account of electrolysis and polarization, usually act promptly only when the number of elements is small, and are to be recommended at the most in those cases in which we wish to change the strength of the current very gradually. The fluid rheostats constructed by Stöhrer according to Ringe's suggestions are very practical; they are filled with a 40 per cent. solution of sulphate of zinc, with amalgamated zinc electrodes. These are simple, cheap, and practically useful.

It appears to me, however, that much praise cannot be bestowed upon any form of rheostat, and that our accessory apparatus for the delicate and uniform gradation of the strength of the current still require very much improvement.

The so-called *conducting wires* serve to convey the current from the polarity changer to the electrodes. They must be as thin and flexible as possible, not unroll nor easily break, and be about 1.5 to 2 m. long. They are best made of very fine, loosely rolled silver or copper wires, or of woollen or silk threads surrounded by metal. They must be well insu-

lated, best by thin rubber tubes, in order to prevent their becoming moist and thus allowing the possibility of unintended accessory closures. It is especially important that their connection with the clamps of the polarity changer and the electrodes be as solid and secure as possible.

For diagnostic and therapeutic purposes the current is conveyed to the human body by means of electrodes. Very much depends upon their size, form, and construction; we still find very unpractical electrodes, which are absolutely insufficient for many purposes. The choice depends entirely upon the purposes which we desire to attain, and is regulated simply by the physical laws which we will discuss in the next lecture.

Metallic electrodes (of brass, preferably well nickel plated) are the

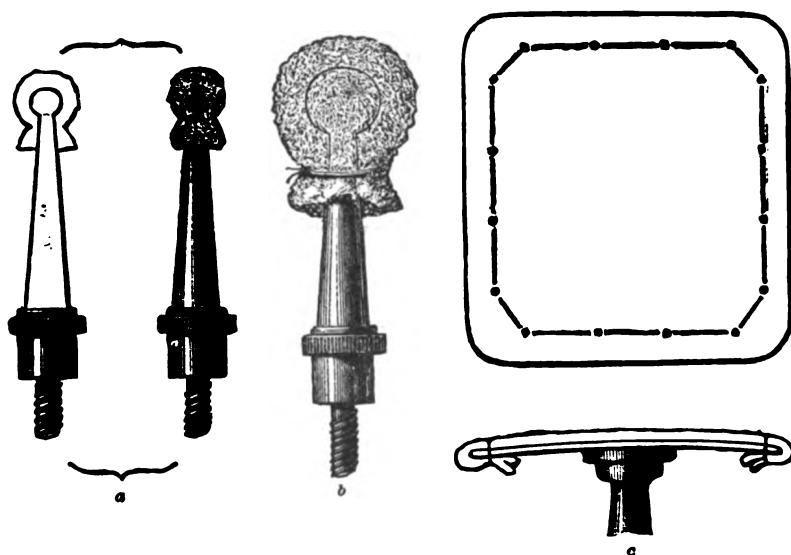

FIG. 6.—Various electrodes (natural size) which may be fastened to the handle represented in Fig. 7. a, "fine" or "smallest" electrode. b, "small" electrode. c, "medium" electrode, slightly convex upon the surface. All the electrodes are metallic and nickel plated, a and b covered with sponge, c, with flannel and linen.

most useful, but those made of carbon may also be employed. The electrodes may be button-shaped or flat; the former are best covered with a moderately thick layer of fine sponge, the flat ones with soft flannel surrounded by a layer of fine linen. Flat electrodes may be square or round; they should be somewhat bent at the edges and angles or have a concave surface, especially the larger forms. Chief attention must be paid to the fact that the covering is not worn at the edges, so that the metal comes through.

The size of the electrodes varies greatly according to the use to which they are to be put; for the most careful localization of the current upon individual points, fine branches of nerves, motor points of muscles, etc., we employ button-shaped electrodes, the diameter of whose sponge cover-

ing is not more than $\frac{1}{2}$ ctm. I shall hereafter call these "fine" or "smallest" electrodes (Fig. 6, *a*). The next larger form, for the stimulation of muscles and larger nerve-trunks, for the application of the current to the eye, face, neck, may have a sponge covering with a diameter of $1\frac{1}{2}$ to 2 ctm. diameter, and they will be called by me "small" electrodes (Fig. 6, *b*). Then comes the flat electrode, which is preferably employed by me for all applications of the galvanic current to the face or neck, for local galvanic stimulation of the nerves and muscles, for quantitative examination of galvanic irritability; this is a square plate, the sides of which are 4 to 5 ctm.

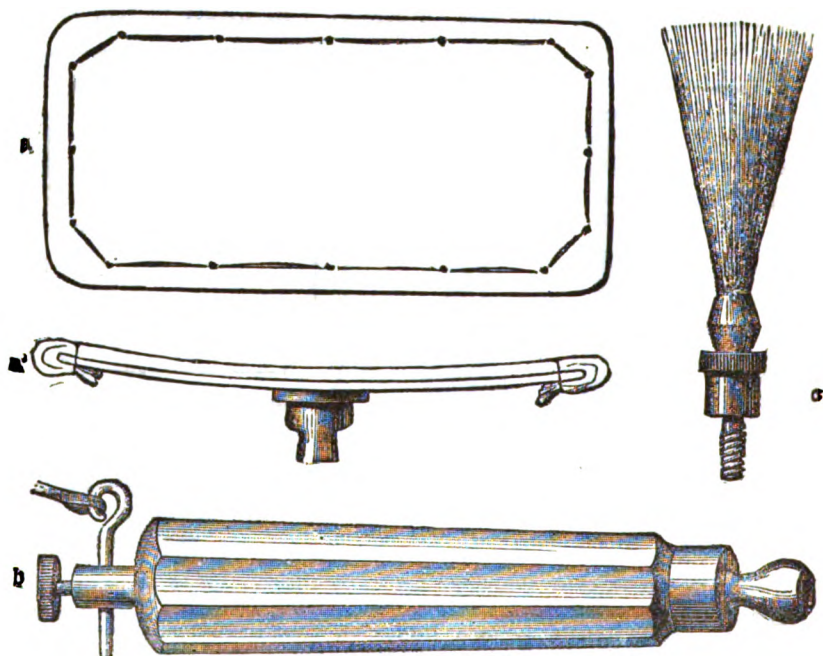

FIG. 7.—*a*, "large" electrode (10-12 ctm. long, 5-6 ctm. wide); *a'*, the same shown transversely. *b*, handle, to which all electrodes can be screwed. *c*, electrical brush.

long, and which I call the "medium" electrode (Fig. 6, *c*). Finally, the "large" electrode, to be employed in all applications to the back in diseases of the spinal cord, in sciatica, in affections of the large joints, and as an indifferent electrode; it is a rectangular plate, concave on the free surface, the sides being 5 to 6 ctm. and 10 to 12 ctm. long (Fig. 7, *a* and *a'*). Still larger electrodes, "very large" ones, will rarely be necessary, but I have occasionally employed such in very fat persons or for special purposes. In galvanizing the brain for various diseases I have recently employed large, plate-shaped electrodes (the sides being 14 to 17 ctm. long), accurately bent according to the curve of the skull; these are covered with a

thick, soft layer of sponge, can therefore be well adapted, and appear to me very serviceable; I will call them "large head electrodes" (Fig. 8).

The majority of these forms of electrodes may also be made of compressed gas carbon, but they present no noteworthy advantages, and the large ones are unpractical on account of their thickness and inflexibility.

The electrodes must be screwed upon good strong handles; the form and size of the latter depend mainly on habit and personal preferences of the electro-therapeutist. I find the strong and large ones (Fig. 7, *b*) most serviceable. For many examinations it is very useful to have handles which are furnished with an interrupting apparatus, so that the current may be opened and closed during the fixation of the electrode by the pressure of the finger.

In their application to the body, the electrodes must always be thoroughly moistened, because otherwise they will not conduct the current;

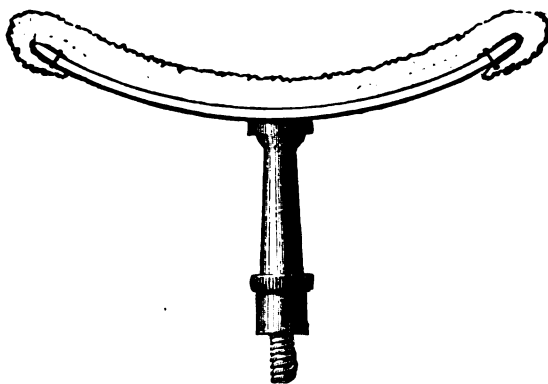

FIG. 8.—"Large head electrode," side view (14 ctm. long, 7 ctm. wide). Flexible, made of metal. Covered with thick, soft sponge.

the unmoistened epidermis is also an extremely poor conductor. The moistening is best done with very warm water. Cold water is a much poorer conductor, moistens the epidermis much more slowly and with more difficulty, and is usually very uncomfortable to the patient. Salt water, though it conducts much better, has so many inconveniences (destruction of the electrodes by electrolysis, more marked burning of the skin, production of stains on the clothes, etc.) that I have long discarded it. At the most I employ it in those cases in which, on account of unusually great resistance, the strength of the battery is insufficient to produce the desired effects.

Hitzig has also employed and recommended "unpolarizable" electrodes for electro-therapeutic purposes. They are said to have the special advantage of being but slightly painful. But as their advantages are by far counterbalanced by the difficulty in handling these electrodes and keeping them in order, they have not secured a foothold in practice.

Apart from those mentioned you will usually need a series of other electrodes for certain special purposes ; thus, especially, a dry metallic electrode, then one made of numerous fine metallic threads in the form of a brush (electrical brush, Fig. 7, *c*), then special electrodes for the treatment of the urethra, bladder, uterus, rectum, pharynx and larynx, recently even the stomach, etc. These consist of polished metallic buttons fastened to a long metallic staff, covered with rubber and of varying thickness, according to the object in view.

This is about all the apparatus which you will need in order to fulfil all the practical and even the majority of the scientific purposes of electro-therapeutics. As a matter of course, it is useful to have all these apparatus arranged in a convenient manner, and so-called electrical tables have therefore been constructed, usually in a very elegant form.

But these are by no means absolutely necessary ; I have never possessed one and have always helped myself in a much more simple manner.

Before leaving this subject, allow me to make a few remarks concerning the determination of the pole which is desirable when we cannot trace directly the connections from the An and Ca of the battery to the connecting wires. This is done most simply by means of the electrolysis of iodide of potassium. Some starch-paste is mixed with a solution of iodide of potassium and the pole wires are placed in it ; the iodine which is set free will produce an intense blue color at the anode. This test is usually insufficient for the faradic current ; the electrolysis is only distinct when the intensity of the current is enormous, or it must be made more distinct by special methods (single opening currents, passage of sparks). The recognition of the poles by the different physiological effects, is as certain as their electrolytic determination. The cathode, if applied to a motor nerve, produces a much stronger muscular contraction on making the current than the anode ; if both poles are applied to the cheeks, the anode will produce a much stronger and distinct gustatory sensation in the tongue than the cathode ; many electro-therapeutists can clearly distinguish the two poles by the quality and color of the flashes of light on galvanizing the eye. You see, then, that we have, at any moment, sufficient means to distinguish the two poles from one another. The cathode of the faradic current (the opening current) may also be readily recognized by its greater irritative effects on motor and sensory nerves.

LECTURE III.

Physical Laws of the Diffusion of the Current and their Application in Electro-therapeutics—Ohm's Law—Strength of Current—Resistance of Various Conductors: Resistance of the Animal Tissues, especially the Epidermis—Individual Differences in Man and their Consequences—Essential and Extra-essential Resistance; Conclusions therefrom Concerning the Construction of Apparatus—Density of the Current and its Laws—Practical Deductions for Various Electro-therapeutical Purposes—Electrolytic and Cataphoric Effects.

In the very large majority of cases it is the expressed desire of the electro-therapeutist to allow the electrical current to act upon certain parts of the body, viz., the diseased parts, with a certain strength, density, and direction, or predominantly with one of the two poles.

You have become acquainted in the previous lectures with the source of the current and the apparatus employed for conveying it conveniently to the body. To-day we must examine how the current can be introduced into the human body, how it can be localized in certain parts in the manner desired. For this purpose, it is necessary that we again recall to mind the laws of the distribution of the current in various conducting parts. The human body is nothing more than a large conducting mass of definite resistance; and the laws controlling the distribution of large conducting masses therefore apply to it without any limitation.

These are the well-known Ohm's laws, and their accurate knowledge is of the greatest importance to the electro-therapeutist. Only by constantly bearing them in mind and utilizing them in a rational manner will you be enabled to apply the current rationally and scientifically. I know of nothing in physics which is of more importanæ to the electro-therapeutist than an accurate knowledge of these very laws.

1. The *strength of the current* (intensity = I) is in the first place dependent upon the electro-motor power (E) of the combinations employed in its production, of the metals and fluids employed in the circuit, of the position of the metals employed in the tension series, of the strength of the inducing magnet or the inducing current, of the number of coils in the cylinders, etc. If all the other conditions are alike, especially the circuit of closure and the external shape of the individual combinations, *the strength of the current is directly proportional to the electro-motor power of one couplet or other source of electricity.*

It follows that various elements and combinations may have a different value and that, in choosing them, consideration must be paid to their varying electro-motor power. If we wish to obtain a certain strength of current—and this must be comparatively great in electro-therapeutics—we must choose elements of relatively great electro motor power, induction apparatus of a certain size whose coils have a sufficiently large number of turns.

2. You will at once discover, however, that although the electro-motor power remains the same, the quality of the circuit of closure has a very decided effect on the strength of the current. (I presume, as a matter of course, that you employ one of the accessory apparatus furnished by physics in measuring the strength of the current.) The circuit of closure introduces a certain resistance ($= R$) to the passage of the current. Circuits of closure of various constructions produce different resistances, and changes in the strength of the current will ensue according to the variations in these resistances. The following law formulates this relation: *the strength of the current is inversely proportional to the resistance in the closed chain.*

From a combination of this law with that previously laid down, it follows directly that the expression of the strength of current of a closed combination is the following: the strength of current is equal to the electro-motor power divided by the resistance, or $I = \frac{E}{R}$.

This statement is of no small practical importance, since we have to deal in the human body—as you will soon learn—with enormous resistance to conduction, and we must therefore choose, for electro-therapeutic purposes, combinations of relatively large electro-motor power, though even then we will only obtain currents of relatively little strength.

3. Further examination will teach you that not alone the quality of the conductor in the circuit of closure will affect the resistance which it presents, but also the form of the conductor. Thus, a certain weight of metal, when it assumes the form of a short, thick cylinder, presents an entirely different resistance to the current from that presented when the metal has the shape of a long wire. It has been found that *the resistance of a conductor is directly proportionate to its length, and is inversely proportionate to its transverse section.*

It therefore follows that the strength of current diminishes with increasing length of the conductor, but increases with its increasing transverse section. *Cæteris paribus* the current will be so much stronger the shorter and thicker the circuit of closure, and so much weaker the longer and thinner it is.

These laws lead to certain deductions with regard to electro-therapeutics, which we will consider somewhat more in detail.

Various conductors present very different resistances to the current.

The metals are the best conductors ; pure silver affords the least resistance, then follow copper, gold, zinc, iron, etc.; mercury presents the greatest resistance, about fifty times as great as that of silver (both are employed as units of resistance).¹

Much greater resistance is presented by the various conducting fluids, such as solutions of salts, diluted acids, etc. ; they present 10,000 to 300,000 times as much resistance as mercury. Pure distilled water is the poorest of all these conductors (about one hundred and twenty million times as great as that of mercury, Zech), but a slight addition of salts or acids increases very markedly its conductivity.

Animal tissues are also poor conductors ; they may be regarded in general as solutions of salts of various concentration, and their conductivity depends in great part upon the blood circulating through them and upon the parenchymatous fluids. The many attempts made to determine the resistance of conduction (C R) of the different tissues have led to various results, but it seems that they do not present any very great differences in this respect, though muscular tissue is the best and bone the poorest conductor. It should also be mentioned that the transverse resistance of the nerves (when the current is directed transversely across them) is five times greater, and that of the muscles about nine times greater than their longitudinal resistance. It seems, then, that the conductivity does not depend solely upon moisture with solutions of salts ; it is, at all events, considerably diminished by the internal polarization which immediately occurs.

In electro-therapeutics, however, we do not have to deal, as a rule, with the exposed animal tissues, but with parts which are covered by the external skin and with its horny layer, the epidermis ; this is a circumstance of the greatest importance, which is too often very little considered. In all ordinary applications of the electrical current to the human body the main resistance is offered by the epidermis. In comparison with this resistance, all others need scarcely be considered ; at all events, the epidermis is decisive with regard to the general strength of the current, though not with regard to the distribution of the current within the body.

The epidermis consists of the mucous and horny layers. The former, consisting of soft, cellular elements, will present approximately the same resistance as the other animal tissues. This is different with regard to the horny layer, consisting of dry, vitreous cells ; this layer may be regarded as non-conducting, offering a very great or absolute resistance to the current, as you can readily demonstrate upon the thick horny layers of the heels and soles of the feet or upon callous hands. Thorough moistening with warm water or a solution of salt is alone capable of restoring the conductivity of this horny epidermis.

¹ The Siemens unit, which is the one most in use, is equal to the resistance of a column of mercury 1 sq. mm. in transverse section and 1 m. in length.

If the horny layer covered the entire surface of the body in a uniform manner, it would indeed augur ill for the ordinary percutaneous application of electricity; at all events, the apparatus at present in use would be insufficient. But, entirely apart from the microscopical interstices between the individual histological constituents of the horny layer, it is also perforated by a large number of more or less closely approximated openings, by the excretory ducts of the sebaceous and sudariparous glands and by the hair-follicles, therefore by canals, which are everywhere covered and permeated by a fluid containing salts; it thus affords the current ready entrance to the deeper layers of the cutis, and in this manner to the interior of the body. The resistance of the epidermis to conduction undoubtedly depends chiefly upon these fine passages for the current, upon their number and their more or less close approximation.

The variations in the thickness and moisture of the epidermis, and in the quantity of hair-follicles and glandular excretory ducts are entirely sufficient to explain the fact that the epidermis presents a varying resistance to the current in different parts of the body, and also that very great differences in resistance are observed in different individuals upon corresponding parts of the body.

Sex and age, race, and habits of life have great influence in this respect; bare portions of skin act differently than covered ones; parts frequently subject to pressure act differently than those which are protected, etc.

The following figures will serve as examples to illustrate the individual and local differences in the resistance of the integument to conduction.

If the same electrodes, with the same amount of moisture and an equal duration of the current, with the same introduction of the galvanometer and constant number of elements, be applied successively to various symmetrical parts of the body, you will obtain, for example, at the following parts of the body the deflections of the needle here indicated:

On both temples.....	40°
“ cheeks.....	50°
“ lateral surfaces of the neck.....	35°
“ scapulæ.....	20°
“ loins.....	5°
“ anterior surfaces of the thighs.....	3°
“ popliteal spaces.....	26°
“ external surfaces of the legs.....	2°
“ anterior surfaces of the arm.....	25°
“ external surfaces of the forearm.....	22°
“ palms of the hands.....	20°

Similar relations will be found in all individuals. The differences of C R (Resistance to Conduction) at similar parts of the skin in different indi-

viduals are often still more striking. In ten healthy young men, I have found the following deflections of the needle with a precisely similar method of application (An on the sternum, Ca upon the ulnar nerve of the right arm):

10°, 18°, 9°, 7°, 6°, 16°, 6°, 16°, 4°, 8°.

In two young girls, the application of the An to the small of the back, the Ca to the neck with a current of ten elements, produced in one 33° deflection of the needle, in the other a deflection of 5° (in the latter, 18 elements were required to produce a deflection of 33°).

In two men suffering from lead palsy, whom I examined at the same time, two series of experiments showed the following considerable differences:

EXPERIMENT I.—An upon the sternum, Ca upon the left deltoid:

CASE A.		CASE B.	
(Aged 44 years).		(Aged 26 years).	
With 6 elements,	31° N. D.	4°	N. D.
“ 4 “	26° “	2°	“
“ 2 “	16° “	0°	“

EXPERIMENT II.—An upon the sternum, Ca upon the right radial nerve:

CASE A.		CASE B.	
With 6 elements,	29° N. D.	7°	N. D.
“ 4 “	24° “	3°	“
“ 2 “	14° “	½°	“

There may thus be enormous differences, and I might multiply these examples much further.

The resistance to conduction also undergoes considerable changes upon the same part of the integument of one individual, on account of the increasing effect of the current, the increased moisture, greater congestion of the skin, etc.

This is extremely important in making quantitative tests of irritability and may be readily demonstrated at any moment. Although the electrodes remain in one position, the deflection of the needle noted in the beginning becomes greater with the duration of the action of the current, the number of elements remaining the same; it increases with every renewed closure of the current, still more upon every change of polarity, and remains finally at a much higher figure than at the beginning of the experiment. The diminution in the resistance becomes still more striking, if we allow successively stronger currents to act and then return to lesser strengths of current. The intimate causes of this diminution of the resistance to conduction on account of the action of the current itself

are not yet entirely apparent ; we may think of the cataphoric action of the current, of changes in polarization, but especially of the action of the current on the blood-vessels of the skin, their dilatation and the greater permeation of the skin with fluid produced in this manner, especially in the vicinity of the hair follicles, sudoriparous glands, etc. (E. Remak). To this cause probably is due also the fact that, for example, the application of a mustard poultice considerably diminishes the resistance of the integument to conduction.

You will be frequently astonished to find how great a resistance to conduction the integument of children presents; this holds good to a still greater extent with reference to old age ; the C R of the skin in old people is often extraordinarily large, so that, for example, you may without any risk employ a number of elements even upon the head, which can not be tolerated at all by the most vigorous young people. You will find, by means of the galvanometer, that this "tolerance" or "brain torpor" reduces itself, as a rule, to a very much increased C R of the skin. Thus, in one man aged seventy years I was compelled to employ 24 Stöhrer's elements (the battery being in good working order) in order to obtain a sufficient strength of current (30° to 35° deflection of the needle).

Hence follows the stringent rule *that we should form an opinion, by means of a few preliminary trials with the galvanometer, concerning the C R of the skin in each individual whom we wish to examine or treat.*

In comparison with the resistance of the epidermis, the length of the portion of the human body included in the circuit need scarcely be considered, or not at all. However great this length may be, it does not much affect the strength of the current ; this depends solely on the condition of the epidermis at the points of application of the electrodes. It is a very striking fact in this connection that upon applying the electrodes to the neck and the popliteal space, the current is very much stronger than if the electrodes are placed at a distance of 10 to 15 ctm. upon both scapulæ or the lumbar region.

This is shown by the following experiment :

A healthy man of middle age ; two "medium" electrodes, A and B, are placed in various positions ; a current of ten elements is closed until the needle comes to rest, then change of polarity made and a second reading of the deflection of the needle, galvanometer 150 C R.

1. Electrode A in the neck, B in the popliteal space, at a distance of 100 ctm. :

Deflection of needle during first direction of current 19° .

Deflection of needle after change of polarity 24° .

2. Electrode A on right, B on left lumbar muscles, at a distance of 10 ctm. :

Deflection of needle during first direction of current 10° .

Deflection of needle after change of polarity 15° .

3. Electrode A upon sternum, B on inner surface of forearm, at a distance of 50 ctm. :
 Deflection of needle during first direction of current 2° .
 Deflection of needle after change of polarity 8° .
4. Electrodes A and B upon inner surface of forearm, at a distance of 5 ctm. :
 Deflection of needle during first direction of current $\frac{1}{2}^{\circ}$.
 Deflection of needle after change of polarity 2° .

In the ordinary application of the current to the human body, therefore, its strength depends mainly on the resistance of the epidermis ; everything else is subordinate. And as the length of this conductor (*i.e.*, the thickness of the epidermis) nowhere presents any considerable differences, it follows that the area of the latter is alone decisive with regard to the strength of the current to be attained in the body ; *i.e.*, the extent of the epidermis which serves for the introduction of the current into the body—in other words, the size of the electrodes applied to the skin determines in the main the strength of the current. What occurs beneath the epidermis is quite immaterial.

It therefore follows that, other things being equal, the electrodes must be so much larger, the greater the strength of the current which we wish to introduce into the body ; this can be readily shown by means of the galvanometer on applying electrodes of various sizes.

As a matter of course, however, the size of the electrodes which may be employed also has its limits. The attempt has been made to render us independent, to a certain extent, of the size of the metallic or carbon electrodes by placing underneath them moistened layers of blotting-paper, by means of which the introduction of the current is to be obtained through a large surface of the epidermis. But this method does not prove very serviceable in practice.

4. As a matter of course the current in a closed circuit passes not alone through the circuit of closure, but also through the element itself, its metals and fluids, and, according to its constitution, naturally meets here with a certain resistance. This resistance, which is situated in the chain itself and caused by its construction, is called the essential resistance, while that met with in the circuit of closure is called the extra-essential resistance. Both are merely parts of the general resistance present in the closed chain and are subject to the same laws. It is therefore also true of the "essential" resistance that it increases with increasing length and diminishes with the increasing diameter of the conductor through which it passes ; or, in other words, the further the two metals in the fluid are separated from one another—the longer therefore the passage through the fluid from one metal to the other—the greater is the resistance (and the weaker the current) ; and the larger the surface of the metal and the deeper the metals are immersed in the fluid, *i.e.*, the greater the area of

the layers of fluid which must be passed through, the smaller will be the resistance (and the stronger the current). The essential resistance also, therefore, influences the strength of the current, and the previously mentioned formula should therefore read : $I = \frac{E}{W+w}$ in which W is the essential and w the extra-essential resistance.

The strength of the current may then be affected by a change in three factors, the electro-motor power, the essential, and the extra-essential resistance. The factor which is unchangeable so far as our purposes are concerned, is the extra-essential resistance (the human body and its parts in the circuit of closure) ; in order to change the strength of current in the circuit of closure we must change one of the other two factors, either increase or diminish the electro-motor power or the essential resistance. A simple consideration will show that, under certain circumstances, we may only do one or the other, that both are not suitable for all cases.

For electro-therapeutical purposes we practically work under two very different conditions : in the ordinary percutaneous application of electricity the circuit of closure contains the human body, which presents an enormous resistance, very much greater than the resistance in the chain itself ; the extra-essential resistance is here much greater than the essential.

In galvano-caustic applications, on the other hand, the circuit of closure is formed by a good conductor, a metallic wire, and this presents a much less resistance than that present in the chain itself ; here the extra-essential resistance is much smaller than the essential. The latter event does not concern us here ; but the mere mention of the fact shows that in the first case a change of the essential resistance remains without any appreciable effect upon the strength of the current, while in the second case, with a small extra-essential resistance, the essential resistance is almost solely decisive with regard to the strength of the current, and therefore changes in it must modify the latter.

It can be readily shown with regard to the first case that if, for example, we wish to increase the strength of the current, we cannot do this by diminishing the essential resistance (enlargement or deeper immersion of the metals, closer approximation to one another, etc.), but only by the addition of new electro-motor power, *i.e.*, by an *increase in the number of elements*.

For our case, *viz.* : the percutaneous application of the current, we will assume that the essential resistance is 8, the extra-essential 200, then—

$$\text{for one element } I = \frac{E}{W+w} = \frac{1}{8+200} = \frac{1}{208} ;$$

$$\text{for two elements } I = \frac{2E}{2W+w} = \frac{2}{16+200} = \frac{2}{216} = \frac{1}{108} ;$$

$$\text{for four elements } I = \frac{4E}{4W+w} = \frac{4}{32+200} = \frac{4}{232} = \frac{1}{58} ;$$

i.e., we have almost doubled the strength of the current by doubling the number of elements, and almost quadrupled it by quadrupling the number.

On the other hand, let us assume that, under the same conditions, the element is enlarged, *i.e.*, the essential resistance is diminished. Assuming the same resistance as above, it will be found that in

$$\text{an element twice as large } I = \frac{E}{\frac{1}{2}W + w} = \frac{1}{4 + 200} = \frac{1}{204};$$

so that the strength of the current has been scarcely affected.

This will occur at once, however, if the essential resistance is great, the extra-essential resistance small, as in the galvano-caustic battery. Assuming now that $W = 200$, $w = 8$, it follows that

$$\text{for one element } I = \frac{E}{W + w} = \frac{1}{200 + 8} = \frac{1}{208};$$

$$\text{for an element twice as large } I = \frac{E}{\frac{1}{2}W + w} = \frac{1}{100 + 8} = \frac{1}{108};$$

$$\text{for an element four times as large } I = \frac{E}{\frac{1}{4}W + w} = \frac{1}{50 + 8} = \frac{1}{58}.$$

It is evident, then, that the intensity of the current is increased by enlargement of the elements, but not by any increase in the number of elements.

The simple conclusion follows for our purposes that, *in the percutaneous application of the current for electro-therapeutical objects, a greater intensity of the current (assuming a given electro-motor combination) can be obtained by an increase in the number of elements and not by an enlargement of the individual elements.*

5. The conception of the density of the current is of special importance with regard to a comprehension of the effects of the current and its proper practical application.

The experience of physiologists teaches that an appreciable stimulating effect upon the peripheral and central nervous system only occurs when the current employed has a certain "density." It is at least probable that a similar condition obtains also for the therapeutic effects of the current, that at least a considerable portion of them are alone produced when the diseased part is brought under the influence of a current of certain density.

By the term density of the current we understand the relation of the strength of the current to the transverse section of the conductor through which it passes. This relation may be understood most readily, as I believe, if you consider the matter figuratively, and suppose the electrical current to be composed of a large number of parallel threads.

The greater the number of threads composing a current, the greater is the strength of the current; the greater the number of threads which are compressed into a unit of the transverse section, the greater is the density of the current. If you imagine a current, for example, of one thousand threads carried through a metallic conductor, 1 sq. *ctm.*, in transverse section, and then through one which has an area of 2 sq. *ctm.*,

the thousand threads in the second case will be dispersed over twice as great an area and the current will possess but half the density, while it will have the same strength in both cases. The adjacent Fig. 9. may serve as an illustration. The current is similar to a girl's loose hair, which may be gathered into a thin coil without changing the number of the hairs.

It seems that appreciable physiological and therapeutical effects do not begin until the number of threads of current, passing through the transverse section of the animal tissues, exceeds a certain limit. It is therefore important to obtain a clear idea of these relations and to render evident those measures by which it is possible to bring any part of the body desired under the influence of a current of a certain density.

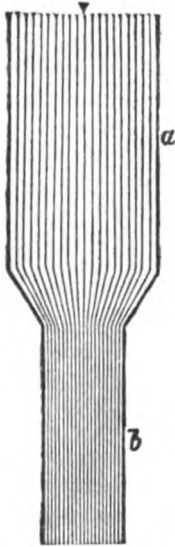

FIG. 9. — Schematic representation of varying density of the current, its strength remaining the same; the same number of threads of current in part *b* of the conductor compressed into half the area of part *a*: the density in *b* is therefore twice as great as in *a*.

For this purpose you must, above all, form an idea of what occurs with the current and its threads, when we introduce them into the body in the ordinary manner, *i.e.*, from two points on the surface of the body, by means of electrodes which are applied to those parts. A number of threads of current corresponding to its strength here enters the body, and is dispersed in all directions according to Ohm's laws. All the threads of the current enter through the surface of the electrodes, and are then spread over the much larger area of the body or parts of the body. The greatest density, therefore, must always be present in the immediate vicinity of the electrodes, and, if these are of equal size, the density of the current will be equal at both electrodes (*vide* Fig. 10); if the electrodes are of different sizes, the greatest density will be found at the smaller one, because the same number of threads of the current are here compressed into a smaller space (*vide* Fig. 11).

In the interior of the body the greatest intensity of the current will be found in the straight line connecting the electrodes (because this presents the least resistance), the largest number of threads of the current will here be accumulated and, therefore, the relatively greatest density of the current will also be found in this situation. But this cannot be very large, since, on account of the great area of the body and the approximately equal conductivity of its parts, the density must diminish markedly very close to the electrodes. However, in especially favorable situations—for example, in transverse conduction through the head with tolerably large electrodes, or in transverse conduction through an extremity—a quite considerable density of the current may be secured, even in the depths of

the tissues. According to the relative position of the electrodes, the zone of relatively greatest density of the current between the electrodes will

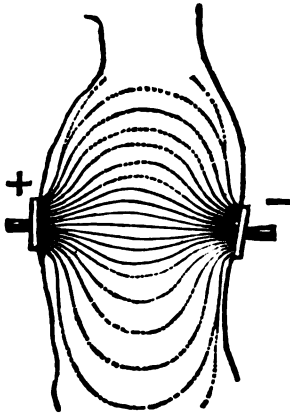

FIG. 10.

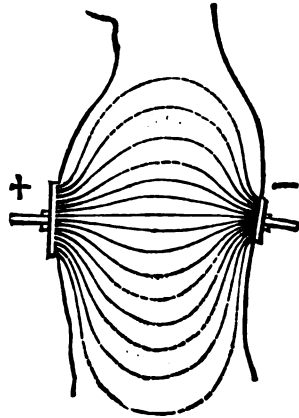

FIG. 11.

FIG. 10.—Schematic representation of the distribution and density of the current with two electrodes of equal size: the density beneath them is equal.

FIG. 11.—Schematic representation of the density of the current with electrodes of different sizes, the An twice as large as the Ca; the density beneath the Ca is twice as great as beneath the An.

vary somewhat in shape; in transverse passage of the current through the body or individual parts this zone will have the shape of a bellied cylinder, extending from one electrode to the other, as in Fig. 12; if, on the other hand, the electrodes are placed near one another upon the surface of the body, it will assume the shape of a section of a sphere or

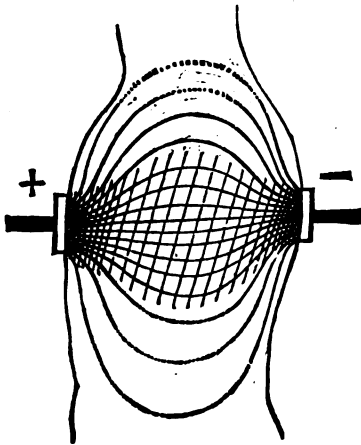

FIG. 12.

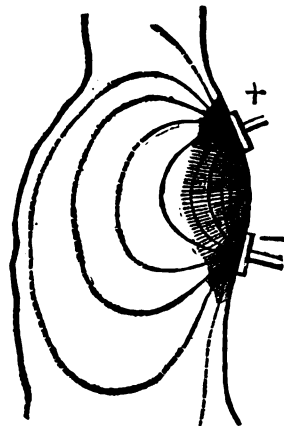

FIG. 13.

FIG. 12.—Schematic representation of the density of the current in its transverse passage through the body. The ineffective threads of current are dotted. The approximate zone of greatest density is shaded.

FIG. 13.—Schematic representation of the density of the current upon application of the electrodes to the same surface, close to one another. Ineffective threads of current dotted. Zone of greatest density shaded.

cylinder, the base of which corresponds to the surface of the body, as represented in Fig. 13. Those parts of the body situated outside of this

zone, although they contain a certain number of threads of current (according to Ohm's laws), nevertheless present such a slight density of current that they may be left entirely out of consideration.

This subject constitutes the quintessence of electro-therapeutical technique. Our object almost always is to localize the current in a certain density upon definite parts of the body, and this can be done only by having a clear idea of the facts just developed with regard to the strength and density of the current. Upon this depends exclusively the choice of the electrodes and their points of application for our various purposes. You will allow me to illustrate this by a few important examples.

If you wish, *a*, to localize the current with a certain intensity and density upon one definite point, not far removed from the surface, two electrodes of different sizes are employed, the smaller one being placed as near

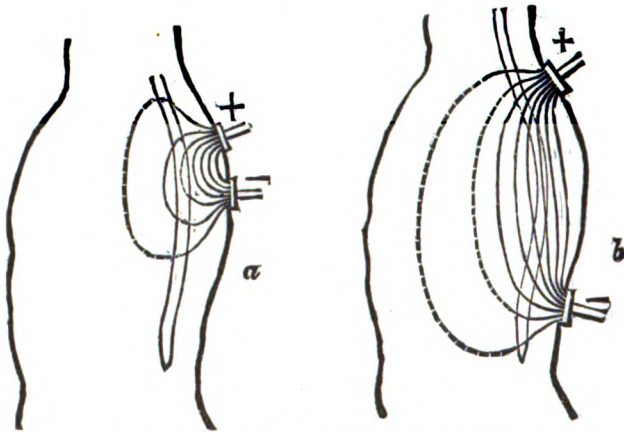

FIG. 14.—Schematic representation of the distribution and density of the threads of current with regard to their entrance deeply into the tissues (in this instance, into the spinal cord). *a*, when the electrodes are in close proximity, *b*, when far removed from one another.

as possible to the point in question, the larger one (as large as possible) at a considerable distance; the end desired will be attained so much more certainly the greater the difference in the size of the electrodes. (If one is very small, the requisite intensity of the current must be secured by an increase in the number of elements, as the smaller surface of the electrode causes a considerably greater resistance.) This is the method employed daily in the electrical examination of individual nerves and branches of nerves, in local stimulation of these parts or of the motor muscular points for therapeutical purposes, etc.

If you wish, *b*, to localize the current upon larger parts near the surface you should choose two moderately large electrodes of equal size and apply them in quite close proximity upon the part of the body in question, so that the latter falls within the spherical segment of relatively greatest density, as shown schematically in Fig. 13. This method should be adopted,

for example, if you desire to electrize energetically the deltoid or biceps, the gluteus or vastus internus or an enlarged joint, etc.

If you intend, *c.*, to localize the current in parts situated deeply, the electrodes should be as large as possible and be placed upon the part in question at the greatest possible distance from one another. The closer the electrodes are to one another the greater will be the difference between the length of those threads of current which pass superficially and those which pass deeply from one electrode to the other, and the greater the number which will remain near the surface. If the electrodes are widely separated this difference will become less, and comparatively more threads of current will pass into the deeper parts, as is shown in Fig. 14. This method is especially employed in the treatment of the spinal cord, which is relatively far removed from the surface; the rule here is "large electrodes, widely separated."

Or two electrodes of equal size are employed and applied in such a manner that the part in question is situated, as far as possible, in the straight line connecting them. This method is especially adapted for treatment of deep-seated diseases of the brain (as is shown clearly in the adjoining figure), but may also be employed to influence circumscribed spots of disease in the spinal cord, for the treatment of morbid processes situated deep in the viscera, etc.

These three methods of application will suffice under all circumstances.

It is worthy of notice that these conditions of dispersion of electrical currents in the human body hold good chiefly, as it seems, for the galvanic current, at least so far as the action upon deeper parts is concerned. As Helmholtz has shown, the faradic current appears to act somewhat differently in this respect, and does not enter deeply with the same rapidity and readiness as the galvanic current. This will explain various electro-therapeutical experiences, such as the fact that deeply situated nerves and muscles are much more readily stimulated by the galvanic than by the faradic current, that the latter does not produce the expected effect upon the spinal cord and brain, the viscera, etc. This is of practical importance.

I will finally refer briefly to two physical effects of the current, which are, perhaps, of no slight significance in electro-therapeutics.

The first is the electrolytic action of electrical currents. You are acquainted with all the details of this action, and I need remind you merely that in the passage of the current through certain compound conductors (electrolytes), these are decomposed into their component parts, the latter being given off at the two poles—the so-called electro-negative elements,

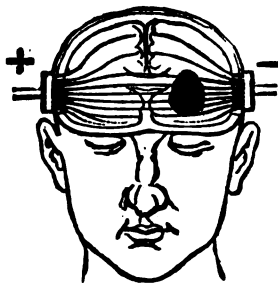

FIG. 15.—Schematic representation of the best method of application of the electrodes in order to bring a lesion, situated deeply in the left cerebral hemisphere, into the field of the most dense and effective threads of current.

oxygen, iodine, chlorine, etc., and the acids, at the anode, the electro-positive elements (hydrogen, potassium, sodium, copper, etc.), the alkalis and bases, at the cathode.

Similar phenomena also occur in animal fluids and tissues ; as Dubois-Reymond, Hermann, and others have shown, the electrolytic processes occur whenever a current passes from another conductor into an electrolyte, when two electrolytes are in apposition and also in the interior of firm masses which are permeated by an electrolyte and through which a current is flowing. The animal organism, when penetrated by an electrical current, presents such a condition ; electrolytic processes will therefore develop within it.

But decomposable fluids, electrolytes, are present also in the elements which produce galvanic currents, and these are subject to electrolysis during the closure of the current. Ions will be separated in a gaseous or solid form at both metal plates, and new electrical currents thus develop in the chain, enfeebling the original main current. This process is called polarization of the current. This is the cause of the inconstancy of the ordinary simple chains, *i.e.*, that their electro-motor force gradually diminishes during the period of closure. You all know of the attempts which have been made to prevent polarization and produce so-called constant elements. This has been effected in the elements of Daniell, Bunsen, Grove, Pincus, Leclanché and others. These are matters of the greatest interest from a physical point of view and for certain technical purposes.

For our purposes, however, really constant elements are an unnecessary luxury, since, on the one hand, even inconstant chains will suffice during the short period of the application of the current, and, on the other hand, even the most constant elements can never succeed in producing an approximately constant current in the human body.

The various forms of current produce very different degrees of electrolytic action ; by far the greatest is possessed by the galvanic current, much less by the magneto-electric induction current, and still less by the faradic current. This is supposed to depend on the very different duration of these currents.

The other physical effect to which I wish to call attention is the so-called mechanical or cataphoric action of the electrical current. It is possibly of great importance in therapeutics and depends upon the fact that during the passage of a current through an electrolyte contained in porous bodies, fluid is impelled from the anode to the cathode, *i.e.*, in the direction of the positive current. The amount of fluid moved in the porous body in a unit of time is so much larger the stronger the current and the poorer the conducting power of the fluid. Firm particles, suspended in the fluid, are said to move in the opposite direction to the fluid itself. It is evident that the animal tissues are constructed in such a manner as to allow the production of these cataphoric effects.

PART II.

PHYSIOLOGICAL INTRODUCTION.

LECTURE IV.

Effects of Electrical Currents on the Healthy, Living Body—Electro-Physiology of the Motor Nerves and the Muscles—Stimulant Action—Pflueger's Law of Contraction—Action of the Poles—Law of Contraction of the Motor Nerves in the Living Body—Polar Method of Examination—Law of Polar Contraction and its Different Grades—Faradic and Galvanic Reaction of the Muscles—Electrotonic Phenomena—Electrotonus in the Living Body—Modifying and Exhilarating Effects.

I now pass to the discussion of the physiological effects of electricity upon the living body. We will first investigate in what manner the electrical current influences the individual organs of the human body under physiological conditions, and what consequences follow its application to these parts. Important deductions may thence be drawn, both with regard to diagnosis as well as treatment of morbid conditions. The electro-physiology of the nervous system and of the muscles teaches us a large number of most important and interesting facts, and has led, in many respects, to a depth and exactness of knowledge, such as are scarcely excelled in any other branch of physiology.

The action of electrical currents upon the motor nerves and muscles is best known and has been most thoroughly studied.

I turn first to the motor nerves, paying special attention to the stimulating effects of electrical currents upon them.

It is a fact which can be demonstrated at any moment that the motor nerves of man or the vertebrates, either laid bare or *in situ*, can be irritated by the application of electrical currents (faradic or galvanic), and that this irritation makes itself apparent by a muscular contraction (in the muscle supplied by the irritated nerve).

This irritation is determined by the law formulated by Dubois-Reymond: "The absolute amount of the density of the current at any certain moment does not act as a stimulant to the motor nerves, but merely the change in its amount from one moment to another, *i.e.*, only the variations

in the density ; these act so much more powerfully the greater they are in a unit of time, or, their amount being equal, the more rapidly they occur ; most powerfully, therefore, upon sudden closure and opening of the current." It therefore follows that, as a rule, a constantly flowing galvanic current does not produce any stimulation during its duration ; furthermore, that very gradual diminution or increase of the current remains without any visible, stimulant effect, even for a great strength of the current ; and finally, that simple variations of density, the current remaining closed, may act as a stimulant, provided that such variations occur in sufficient amount and with a certain rapidity.

Hence follows, also, the vigorous irritative effect of faradic currents upon the motor nerves, because they are composed of currents of very brief duration and thus produce very considerable and very sudden variations of density. If induction currents are allowed to act upon the motor nerves, each one will be followed by a short muscular contraction, corresponding to the strength of the induction current ; the contractions, therefore, are more vigorous during the opening than during the closing current of the secondary spiral. If a series of such currents act upon the nerves, an identical series of muscular contractions will follow ; if the succession of these irritants attains a certain rapidity, the individual contractions will be collected into a single permanent, so-called tetanic contraction. It is unnecessary to enter into the details of the irritant effect of faradic currents ; it will suffice to mention that usually the individual induction currents act merely like closure of the current, the opening producing a scarcely noticeable contraction.

Every sufficiently large variation in the density of a galvanic current, if conveyed to a nerve, produces an irritation of the nerve and at the same time a muscular contraction ; this occurs most certainly during the variations of density connected with making and breaking the current. It was early recognized that the stimulant effects upon opening and closing currents of various strengths, and also on changing the direction of the current in the nerve, are very different, and much labor has been devoted to discovering the relations of these differences. These have been formulated by Pflueger in his law of contraction. This law—which holds good only when the nerve is laid bare and well isolated—is as follows :

With *weak* currents, in both directions, contraction occurs on closure alone, but none is produced on opening ; the contraction on closure of the ascending current is somewhat stronger than that of the descending ;

With *moderate* currents, contractions occur on opening and closing in both directions ; but the former are always weaker than the latter ;

With *very strong* currents (such as are never employed upon human beings), contraction occurs on opening but none on closure of the ascending current ; and it also occurs on closure but not on opening of the descending current.

All these phenomena and phases of the law of contraction are based upon well-founded facts. The most important of these is that the irritative effect of the galvanic current occurs only at the poles and starts from them ; the irritation on closure occurs at the cathode alone, on opening at the anode alone. Pflueger also found that the irritant action of the cathode is greater than that of the anode, and thus the irritation at the closure of a certain current is greater than at the opening. It was further found that the more central portion of a motor nerve is more irritable than the peripheral portion and, finally, that with very strong currents considerable resistance to the propagation of the irritation occurs at both poles, and increases with the strength and the period of closure of the current. Pflueger's law is thus explained in the simplest manner: with *weak* currents, contraction occurs only on closure in both directions of the current, because contraction on closure is the stronger and appears first ; contraction on closure of the ascending current appears somewhat earlier because the central part of the nerve on which the cathode is placed is somewhat more irritable. When the current is *moderately strong*, the closure contraction in both directions of the current is stronger than the opening contraction on account of the predominant irritative effect of the cathode. When the currents are *very strong*, the resistance to conduction, which develops at the poles and disappears but slowly, inhibits the propagation of the closure irritation when the current is ascending, and the propagation of the opening irritation to the muscle when the current is descending, and thus produces the peculiar third stage of the law of contraction.

It follows from the previous remarks that the phenomena of the law of contraction depend alone upon the different effects of the two poles, and that the irritation on closure (Ca action) is considerably greater than that on opening (An action).

When the current is strong, its closure is not followed by a simple short contraction, but often by a long-drawn tonic or tetanic contraction which gradually subsides (closure tonus or closure tetanus, C Te). An entirely satisfactory explanation of this phenomenon has not been offered, and I have referred to it because it is readily produced in the human subject. Opening tetanus, *i.e.*, a vigorous opening contraction of a tonic, protracted character occurs only in such nerves whose irritability has been very much increased ; it is readily explained by Pflueger's law of electrotonus. In the human subject it occurs with extreme rarity and, as it seems, in pathological cases alone.

Pflueger's laws also explain another phenomenon which was first known as Volta's alternatives ; if the current has been closed for some time in one direction, the irritability of the nerve is increased to opening in the same direction or closure in the opposite ; repeated changes in the direction of the current therefore produce a considerable increase in the amount of contraction. This cannot be entirely explained by the diminution in the

resistance to conduction, but rather by the summation of the irritating effect of the anode (disappearance of anelectrotonus) and of the cathode (development of catelectrotonus) at one part of the nerve (alternating at each change of polarity).

Rumpf has recently shown, by a series of physiological experiments, that, in a motor nerve which is still connected with the central organ, the opening contraction of the ascending current occurs considerably later than in one which is separated from the central organ. This is observed occasionally under pathological conditions.

I will add further that motor nerves are entirely non-irritable to the strictly transverse passage of the current (faradic or galvanic), and also to very short (under 0.0015 second) galvanic currents, a characteristic, however, which is much more marked in muscles.

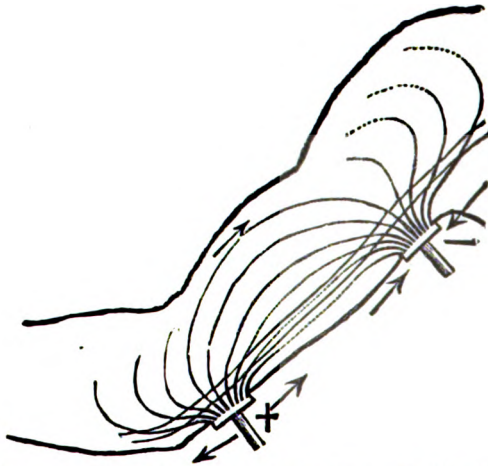

FIG. 16.—Schematic representation of the effective threads of current in the ordinary percutaneous application of both electrodes to a nerve (ulnar nerve in the arm). The ineffective threads of current are dotted. There are four different directions of the current in the nerve.

For the practical physician, however, the question arises whether the law of contraction can be demonstrated upon the motor nerves of the living and healthy human being. Experience teaches that this is possible, despite the great obstacles presented. But our experiments on this subject cannot compare in exactness with those of the physiologist. We have to deal with nerves which are surrounded by more or less thick layers of good conducting tissues and which are followed by a large number of the threads of current; we cannot therefore maintain uniform density of the current in the nerve. The greatest density of the current will be found immediately beneath the electrodes; even in the intrapolar portions of the nerves, the density will soon become so slight, if the electrodes are not closely approximated, that a part of the nerve may be regarded as not traversed by the current. And it will be impossible to maintain a definite, single di-

rection of the current in the living nerve, surrounded as it is by soft parts. A glance at the adjoining plate (Fig. 16), will show that in ordinary percutaneous application, not less than three, perhaps even four efficient directions of the current must be present in such a nerve.

The direction of the current must therefore be left out of consideration; we must endeavor to find a law of contraction of the living motor nerves in the healthy body, without any reference to the direction of the current.

In fact, there is no doubt that the problem may be simplified by merely testing the action of the poles in the living human being. This problem is solved without much difficulty. If but one pole is brought into the immediate vicinity of the nerve to be tested, and the other removed as far as possible, the density of the current under the first pole will be so great that its action will be brought into play almost exclu-

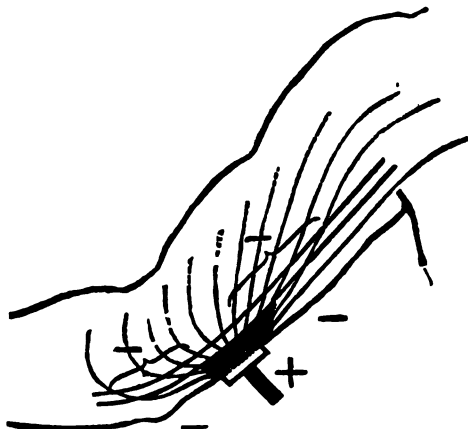

FIG. 17.—Schematic representation of the primary and secondary (virtual) polar action upon unipolar application of the electrode over a nerve-trunk.

sively, this may then be examined separately on closure and opening, and with an increasing strength of current. This is the so-called polar method of examination from which Brenner developed also a polar method of therapeutics.

But this method also presents difficulties and peculiarities. We can by no means produce an entirely isolated action of the poles in any nerve; if the current enters a nerve at any point (that is, if there is an anode at any part of the nerve) it must make its exit at some other, perhaps at various places (*i.e.*, it must have a cathode somewhere). It will depend solely upon the density of the current of exit in how far this second, virtual, pole comes into play. In fact, a glance at Fig. 17, will show that an isolated pole placed upon a nerve must have not alone one, but even two opposite poles in its immediate neighborhood. If the current enters

through the anode in a certain density the threads of current will flow along both directions of the nerve with diminishing density; the cathode may be regarded as present at the point at which the density has become so slight that the current is ineffective. Every anode is therefore surrounded by two cathodes of much less density, and the reverse occurs when the isolated cathode is applied to the nerve. Under all circumstances, in this method of application, in addition to the action of the pole applied directly, we must therefore expect to find the action of the opposite pole, though very much enfeebled.

In the polar method of examination one electrode, termed the "active" one, is brought in as close approximation as possible to the nerve to be examined, and then connected, as desired, with the An or Ca of the battery. The other or "indifferent" electrode is placed on some remote part of the body (sternum, spine, epigastrium, popliteal space); I always employ the sternum, to which the electrode can readily be applied by the person examined.

The requisite making and breaking of the circuit are best done by means of the metallic polarity changer; if the Ca is on the nerve and the circuit is closed this is called "making a cathodal closure," Ca Cl; if the circuit is opened, "cathodal opening," Ca O; and similarly with the anode.

It is best to begin (with a definite slight strength of current) by examining Ca C in about three closures, and at the same time observing Ca O; An C and An O are then examined in the same manner; to secure the opening contraction it is advisable to keep the current closed for a little while, as this increases the irritability on opening the circuit. With an increasing strength of current we then examine at what intensity the various forms of contraction are produced, and can then arrange them in a formula, in which the various degrees of contraction are represented as C, C', C'', or C, CC, CCC, etc., according to the strength of the contraction. In making these examinations you should employ the greatest similarity and regularity of method, because in this way alone can you arrive at results which may be compared with one another and can avoid, to a certain extent, the numerous sources of error of such investigations in the human subject.

By this method you may readily demonstrate, in the majority of the motor nerves, that the cathode *chiefly* produces stimulation on closure, the anode *chiefly* on opening; you will also find that the stimulant action of the cathode is much greater than that of the anode.

From these statements it is evident that the first contraction which occurs upon stimulation of a motor nerve is Ca Cl C. As an illustration let us take the ulnar nerve. You will find that, perhaps with eight elements, Ca Cl C first develops, but no contraction occurs at Ca O, An Cl, and An O; with ten elements, Ca Cl C becomes stronger, and a feeble An Cl C occurs; perhaps also a feeble An O C. With twelve elements, Ca

Ca C' becomes very active, perhaps assumes a slight tonic character (weak Ca Cl Te), An Cl C and An O C become stronger, especially the latter; Ca O is still inefficient. Finally, with fourteen, sixteen, or eighteen elements, you will observe Ca Cl Te', An Cl C, An O C', and finally distinct Ca O C, though this always possesses little strength.

We may therefore distinguish three stages of the law of contraction.

First stage (feeble current) : Ca Cl C.

Second stage (moderate current) : Ca Cl C' stronger. An Cl C and An O C also occur, both of approximately equal strength, though sometimes one, sometimes the other develops a little earlier in different nerves. The latter differences are undoubtedly due to the anatomical position of the nerves and to the density of the threads of currents producing the secondary polar action which is dependent thereon.

Third stage (strong current) : Ca Cl C becomes tonic and = Ca Cl Te; An Cl C and especially An O C' become more powerful, and at the same time weak Ca O C occurs.

Further stages do not occur in the living, healthy individual; a still higher stage would be the occurrence of anodal opening tetanus, but this has not been observed to my knowledge in the healthy motor nerves of man. With very high strengths of current, it is easier to produce a slight prolongation and tonic character of An Cl C.

In formulating the law of contraction, Brenner has introduced a very simple and practical formula, which contains the six possible stimulant factors (Ca Cl, Ca D = cathodal duration, *i.e.*, the period of closure of the circuit; what is termed closure tetanus is a Ca D reaction, and Ca O, An Cl, An D = anodal duration, An O), next to which the strength and duration of the contractions may be appended in a manner readily understood. The following is the formula for the three stages of the law of motor contraction :

First stage.	Second stage.	Third stage.
Ca Cl C	Ca Cl C'	Ca Cl C''
Ca D—	Ca D—	Ca D C>
Ca O—	Ca O—	Ca O C
An Cl—	An Cl C	An Cl C
An D—	An D—	An D—
An O—	An O C'	An O C'

The above mentioned facts will be made clearer, perhaps, by the schematic representation of the different strengths of the contractions in the individual factors of irritation. The strength of the individual contractions in any nerve is, *ceteris paribus*, the product of the amount of irritation of the acting pole (I) and the density of the current at the point of irritation (D), *i.e.*, C = I D. We will assume that the amount of irritation of the Ca = 1, of the An = $\frac{1}{2}$. We will also assume the density of the current at the active electrode (in the most shaded part of Fig. 18) = 1,

and, on the other hand = $\frac{1}{2}$ at the point of secondary polar action (in the lightly shaded parts above the electrode).

If the Ca is the active electrode, it acts upon closure of the current with an amount of irritation 1 and density 1; Ca Cl C is therefore 1×1 , and has the strength 1. Upon opening the current, the irritant action occurs at the virtual An with an amount of irritation of the An = $\frac{1}{2}$ and a density $\frac{1}{2}$. Ca O C accordingly is $\frac{1}{2} \times \frac{1}{2}$, and has a strength $\frac{1}{4}$.

If the An is the active electrode the stimulation upon closure of the

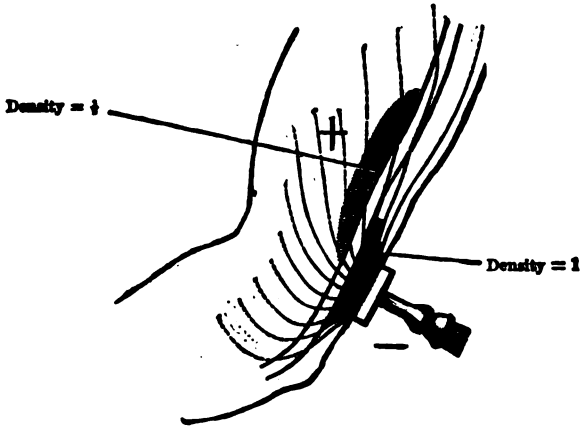

FIG. 18.—Schematic representation of the varying density at the active (—) and the virtual (+) pole upon unipolar application of the Ca to the nerve.

current occurs at the virtual cathode, with an amount of irritation of the Ca = 1 and density $\frac{1}{2}$; An Cl C accordingly is $1 \times \frac{1}{2}$, and has a strength $\frac{1}{2}$.

Upon opening the current the irritation occurs at the An itself, with an amount of irritation $\frac{1}{2}$ and density 1; An O C accordingly is $\frac{1}{2} \times 1$ and has a strength $\frac{1}{2}$.

For a definite strength of current, the amount of contraction with the various forms of stimulation may be accordingly formulated as follows :

$$\begin{aligned} \text{Ca Cl C} &= 4 \\ \text{An Cl C} &= 2 \\ \text{An O C} &= 2 \\ \text{Ca O C} &= 1 \end{aligned}$$

The electrical irritability of the voluntary muscles has long been a subject of dispute and never-ending labor to the physiologist. The much-disputed question whether the muscles possess irritability independent of the motor nerves (or more properly stated, whether the undoubted irritability of the muscles can be brought into action by other means than through the motor nerves) appears to be settled finally, and the occurrence of muscular irritability to be established beyond a doubt. This question, of purely theoretical interest to the physiologist, has a not inconsiderable significance to the pathologist, since, apart from pathological irritative processes in the muscular tissue itself, we meet not infrequently with morbid

processes in which muscular irritability is demonstrable apart from all action on the part of the motor nerves, and can be employed by us for important diagnostic and prognostic purposes.

It has been found by physiologists that Dubois-Reymond's law of stimulation also holds good for the muscles.

The muscular tissue reacts much less than do the nerves to currents of very short duration ; its irritation by faradic currents is therefore somewhat more difficult than by galvanic.

But the faradic current acts upon the muscle, as upon the nerve, with a contraction at each single induction stroke of a certain strength, and with a tetanic contraction upon a rapid succession.

The law of galvanic contraction of the muscles appears to be entirely analogous to that of the motor nerves, and to depend upon the fact that the closure stimulation occurs alone at the Ca, the opening irritation alone at the An. With a moderate strength of current closure and opening contractions occur at both poles, but the latter are much weaker and often entirely absent ; an opening contraction only occurs regularly with greater strength of current and very prolonged duration of closure. With strong currents a certain degree of shortening of the muscles remains after the closure as well as the opening contraction (closure and opening duration contraction).

The examination of direct muscular irritability in the human subject meets with special difficulties, and we possess very little definite knowledge on this subject.

The living muscles react with more or less vigorous tetanic contraction (according to the strength of the current) to faradism, and with single contractions to individual induction currents. This occurs so much more readily the closer the electrodes are approximated to the points of entrance of the motor nerve-branches into the muscle, or touch these directly (motor points). Upon this depends the method of local faradization of the muscles.

The galvanic reaction of the muscles occurs in such a manner that they respond to stimulation with both poles by a closure contraction alone, the opening contraction being absent or obtained only exceptionally. The latter fact is perhaps explained by the slight irritability of the muscles to the short opening irritation. The closure contractions are short and vigorous, but frequently they do not seem to me to be as prompt as after irritation of the nerves ; they often show a slight tendency to tonic contraction, but are never markedly slow.

But Ca Cl C is not much greater than An Cl C, and this is a distinct difference from the normal condition of the nerves.

To a certain extent, an isolated irritation of the muscles of the body by the galvanic current, a local galvanization, may be effected, and is based upon the same principles and methods as local faradization.

A second, very important group of effects of the electrical current upon the motor nerves are the so-called modifying, irritability changing, electrotonic effects. We mean those effects of electrical, especially galvanic, currents which are expressed by a change in the electrical, thermal, or mechanical irritability of the motor nerves (and muscles) during the passage and after the cessation of the current; these are included under the term electrotonic phenomena.

The following are the essential features of the doctrine of electrotonus:

A galvanic current passing longitudinally along a motor nerve (polarizing current) changes its irritability along the entire length most markedly in the vicinity of both poles. At the cathode and its vicinity the electrical, mechanical, and thermal irritability is increased (catelectrotonus); at the anode and its vicinity it is diminished (anelectrotonus). Both increase with the duration and intensity of the polarizing current and touch one another in an indifferent point of the intrapolar region. The change of irritability is greatest at the electrodes and diminishes in a curve on each side; within the intrapolar region this curve cuts the line of co-ordinates at the indifferent point.

Upon breaking the polarizing current the negative modification of the irritability of the anode (anelectrotonus) is changed at once to a very marked positive modification, which requires some time for its disappearance; at the Ca, on the other hand, a brief negative modification of irritability first occurs, but very rapidly passes into a vigorous positive modification with increase of the irritability, and then gradually returns to the normal condition. After breaking the polarizing current, therefore, a more or less prolonged increase of irritability persists at both poles.

Many attempts have been made to demonstrate the electrotonic phenomena in the living human subject, and these attempts may, in the main, be regarded as successful.

However, the first attempts made by Eulenberg and by myself furnished diametrically opposite results. Eulenberg's result coincided entirely with those obtained by physiologists; mine showed diminution of irritability near the Ca, increase of irritability near the An. But I am perfectly satisfied with regard to the correctness of my results. They are explained by the dispersion of the current and the rapidly diminishing density in the vicinity of the polarizing electrodes, *i.e.*, by the two virtual electrodes of an opposite sign which are present in the neighborhood of each electrode (*vide* Fig. 17). If, in view of these considerations, I placed the irritating electrode immediately at or within the polarizing electrode, regular catelectrotonus and anelectrotonus was presented, as in physiological experiments. These phenomena have also been studied by others, though unsatisfactorily, and a review of the entire question is desirable. For the present we may remain satisfied with the result that it is possible

to demonstrate the electrotonic phenomena upon the motor nerves of the living human subject. But we recognize the fact that the conditions are much more complicated than in the isolated nerve-muscle preparation, and that we are unable to polarize longer stretches of the nerve in a uniform manner. Indeed, as shown in the adjoining figure (Fig. 19), we always obtain a series of not less than six—or in unipolar stimulation, at least three—anelectrotonic and cat:lectrotonic portions of the nerve.

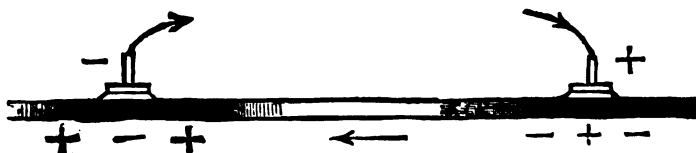

FIG. 19.—Schematic representation of varying polarization of the nerve in bipolar percutaneous application of the electrodes. The anelectrotonic parts are shaded transversely, the cat:lectrotonic parts vertically.

Of more importance to the therapist are the more or less persistent effects which remain after opening the circuit, *i.e.*, the—perhaps permanent—modification after opening the polarizing current. Physiology teaches that, under these circumstances, an increase of irritability remains at both poles; but the rapid return to the normal condition is by no means very promising with regard to permanent changes under pathological conditions.

The attempt has been made to demonstrate this positive modification upon the intact nerves of the human subject. Remak, in his experiments, came to the conclusion that cathodal duration produces a positive modification of Ca Cl C, but this occurs after anodal duration to a slighter degree, and only when the experiment is modified. These results need verification; their real utility in therapeutics is very problematical.

LECTURE V.

Electro-physiology of the Sensory Nerves and Nerves of Special Sense—Sensory Nerves of the Skin and their Law of Contraction—Sensory Nerves of the Muscles—Optic Nerve and Retina—Acoustic Nerve and the Nervous Auditory Apparatus—Nerves of Taste—Nerves of Smell.

WITH regard to the sensory nerves of the skin the question arises whether the galvanic current stimulates them by its continuous passage or by variations of density alone. At all events, the application of a sufficient strength of current to the skin causes a continuous sensation, a peculiar pricking, and this soon passes into a uniform burning which may increase to the most severe pain. A large share of this sensation, especially the uniform burning, may be due to the irritating effect of the chemical substances which are set free at the surface of the body by electrolysis: another part is probably due to the direct action of the current upon the sensory apparatus in the skin. Many physiologists lean toward the view that the sensory terminal organs react differently to the current than do the conducting paths, that they are not alone stimulated by variations of density, but also by the constant passage of the current. This is, to a certain extent, negatived by the fact that continuous irritation of a nerve trunk causes a continuous eccentric sensation in its region of distribution.

It is well known that experiments on animals throw a very imperfect light upon the phenomena observed in the sensory nerves. A so-called law of contraction of these nerves has only been obtained in a round-about way, inasmuch as the reflexes occurring upon irritation of them (in slightly strychninized animals) were employed as indications of the sensory irritation. By means of this method Pflueger found the law of contraction of sensory nerves to be in complete harmony with that of the motor nerves, *mutatis mutandis*, i. e., with the differences necessarily produced by the direction of the conduction in sensory nerves (for the third stage).

In the sensory nerves of the human subject, however, it is evident that the polar method of examination is the only one which can be employed, and that the problem consists in determining the reaction of these nerves at both poles on making and breaking the current, and with different strengths of current. I have recently shown that there is a striking similarity in these respects to the law of polar motor contraction.

The sensory irritations produced by the galvanic current appear not alone in that part of the skin covered by the active electrode, but also in the region of distribution of those sensory nerves of the skin whose trunk lies within the boundary of this electrode. With a gradually increasing strength of current, a brief Ca Cl sensation first develops, which, with a stronger current, passes into a permanent pricking, eccentric, and local sensation, whose intensity gradually diminishes during Ca D; then follows a similar feebler, short An O sensation; somewhat later a feeble An Cl sensation, which only passes into an An D sensation with still stronger currents; finally, with a relatively great strength of current, if the Ca D sensation has been allowed gradually to subside, a feeble, but distinct, Ca O sensation develops (during the entire experiment a lively burning sensation is felt in addition to the pricking one, and is confined exactly to the surface of contact of the electrode). Here also it is evident that the Ca chiefly produces closure reaction, the An opening reaction, and that the stimulant effect of the Ca predominates markedly.

The sensation produced by the action of the faradic current upon the nerves of the skin is a peculiar one; every induction stroke causes a short, sticking sensation, which increases, if the armature vibrates freely, to a continuous pricking, and (especially under the use of dry metal electrodes, or the metallic brush) to a burning and very painful sensation. If a sensory nerve trunk is directly irritated, a peculiar eccentric pricking sensation is felt in the entire region of distribution; this is much stronger on irritation with the Ca of the opening current than with the An. Individual strokes of the current are not so painful as rapidly repeated ones, and the intensity of the faradic sensation or the pain increases with the rapidity of the interruptions.

The sensory nerves of the muscles cannot be readily examined when isolated, except in muscles which have been laid bare by wounds, etc., or in complete anæsthesia of the skin, and under these circumstances a sensory impression has never been observed in the muscles without a simultaneous contraction. Every vigorous muscular contraction is accompanied by a distinct sensation, which has nothing in common with tegumentary sensations and may increase to actual pain during tetanic contraction; this constitutes the electro-muscular sensibility. It is a peculiar, dull, tensile sensation, which is directly proportionate to the muscular contraction. This sensation also becomes distinct with strong galvanic currents, as soon as they produce a tetanic contraction of the muscles.

Much more interesting results are furnished by electrical examination of the nerves of special sense, or rather the organs of special sense (we have to deal chiefly with the stimulation of terminal apparatus, retina, concha, semicircular canals, etc.). As a matter of course such experiments can be made upon the human subject alone.

With regard to electrical irritation of the organs of special sense, it

may be premised that they react very slightly or not at all to the faradic current.

On the other hand, these organs react to the galvanic current with comparative, in part with extreme readiness, and they do this by their specific sensations; it can be easily shown that these sensations are dependent on the influence of the two poles. It is self-evident that we always have to deal with a direct galvanic irritation of the nervous apparatus of the special senses in question.

The eye, *i.e.*, the optic nerve or retina, reacts most readily to the galvanic current. You need simply pass a very weak current through the temples or cheeks, and flashes of light will appear on making or breaking the current, their intensity becoming greater with the increase in the strength of the current. The same observation may be made if somewhat stronger currents are applied at a distance from the eye, upon the neck or even the chest and back, thus showing the great sensibility of the retina to galvanic currents. Helmholtz describes very accurately the sensations of light and color in his variously modified experiments, and endeavors to explain them upon the basis of electrotonic laws with reference to the direction of the current in the retina and the fibres of the optic nerve situated therein.

But it is useless to attempt to explain the variations in the sensations of light by the difference in the direction of the current. The anatomical arrangement of the optic nerve fibres in the retina renders such an attempt hopeless.

Brenner has shown that the galvanic stimulation of the nervous apparatus of sight is essentially a polar action, and he has formulated the following law:

At the application of each of the poles to the eye, a lightning-like sensation of light is felt upon making and breaking the current, though differing qualitatively (different colors); the sensations of light and color at Ca Cl are qualitatively like those at An O, and those at An Cl like those at Ca O; for example;

Experiment a.	Experiment b.
Ca Cl: reddish light.....	whitish yellow.
Ca O: bluish light.....	blue.
An Cl: bluish light.....	blue.
An O: reddish light.....	whitish yellow.

With a current of moderate strength, the sensation is that of a sudden glow of light, like heat lightning, illuminating the dark field of vision and (sometimes with difficulty) permitting the recognition of a more or less distinct color; this may be so decided that both poles may thereby be distinguished from one another after a little practice.

In many individuals with good powers of observation a further differen-

tiation occurs, inasmuch as a bright-colored, shining patch appears in the centre of the field of vision ; this is surrounded by a paler glow of light, a sort of circle. This is shown by the following illustration :

Ca Cl: blue centre, yellowish green rim.

Ca O: yellowish green centre, bright blue rim.

An Cl: yellowish green centre, bright blue rim.

An O: blue centre, yellowish green rim.

The colors vary greatly in different persons, but they are always alike in the same individual.

The chief phenomena of the galvano-optic reaction in most individuals, who possess a certain gift of observation, can be obtained with readiness with a very slight strength of current (4-6-8 elements, the indifferent electrode being placed upon the neck or sternum, the active one upon the closed lids or the temples, in a moderately darkened room).

It is noteworthy from a theoretical point of view that Ca Cl and An O, and also Ca O and An Cl, produce qualitatively identical sensations. The conclusion might be drawn that Ca at opening and An at closure have a definite stimulant effect different from the closure stimulation of Ca and opening stimulation of An ; but it is more correct to assume that the difference is due to a change in the locality of irritation in Ca O and An Cl, since these must be regarded as secondary polar effects (of the virtual An and Ca).

It would be interesting and important to know whether the galvanic visual sensation occurs from irritation of the retina or optic nerve, or from irritation of the layer of nerve fibres in the retina, but this question is still undecided.

I will also make brief mention of the reaction of the iris to the electrical current. Its muscular tissue reacts promptly to the faradic current, and, by a suitable arrangement of the electrodes, the sphincter pupillæ and dilator pupillæ can be made to contract separately ; this can also be done by stimulating their nerve trunks (motor oculi communis and cervical sympathetic).

The latter has not been effected hitherto in the human subject ; the direct stimulation, also, has been tried by very few (Duchenne), and is only possible in chloroform narcosis or anæsthesia of the cornea. Two fine wire electrodes (best armed with the same pole, the other being placed upon the trunk) are applied 2-3 mm. from the edge of the cornea ; with a sufficient strength of current, marked contraction of the pupil will occur.

Attention has long been paid to the galvanic stimulation of the auditory apparatus, but it was reserved for Brenner to demonstrate its law of contraction.

Stimulation of the acoustic nerve in healthy persons is not easy; the nerve is situated so deep that quite strong currents are necessary to produce irritation, and these give rise to such disagreeable auxiliary phenomena (from irritation of the eye, sensory nerves, nerves of taste and salivation, facial nerve, and especially the brain) that many healthy individuals only accustom themselves gradually to observe the auditory sensations. Were it not for the fact that so many patients suffering from ear diseases present a very marked increase of galvanic irritability, we would, perhaps, still be searching for the law of stimulation of the normal auditory apparatus. With perseverance, however, this can also be determined in the majority of healthy individuals.

This is done at present by the so-called external method; a large moist sponge electrode ("medium size") is placed immediately in front of the auditory canal, pressing slightly upon the tragus, but without occluding the canal or filling it with water. The indifferent electrode is placed on the back of the neck. The strength of the current being increased, repeated cathodal closures, at times An Cl are made, or, if the irritability is very slight, repeated changes of polarity; the person experimented upon is directed to pay close attention to his auditory sensations.¹

An extremely simple formula will thus be elicited; the normal auditory apparatus only gives a sensation at closure upon irritation with the Ca, and only at opening upon irritation with the An, the former being much stronger and appearing earlier than the latter. The normal formula of the acoustic nerve, therefore, with a moderate strength of current is: only Ca Cl S (sensation of sound); with a stronger current, it is the following:

Ca Cl S, loud sound.
 Ca O, nothing.
 An Cl, nothing.
 An Os, feeble noise.

The quality of the sounds varies somewhat, but not so much in healthy individuals as in those suffering from ear diseases. Healthy individuals usually hear a more or less loud whistling or hissing, or perhaps a roaring or buzzing. The An O reaction is usually very feeble and short. With increasing strength of current, the auditory sensations increase in intensity, distinctness, and duration, and assume a more musical or whistling character.

We find in this nerve of special sense that the physiological law of different polar action—the Ca stimulating only at closure, the An only at opening—is presented with remarkable precision and clearness.

¹ For further details, vide Brenner's book and my articles in the Knapp-Moos' Archiv für Augen- u. Ohrenheilkunde.

But we must ask ourselves why purely polar effects are alone obtained in this nerve? According to our previous statements, an anode is inevitably present in a nerve presenting a cathode, and here, as in the motor nerves, we should expect, upon irritation with the Ca the action of the secondary virtual An. Why does this not happen in the present case? Hitzig has endeavored to explain this phenomenon by the anatomical relations (the position of the nerve in a bony canal, its direct transition into the brain tissue, the divergence of the acoustic fibres in the central organ), on account of which the density of the threads of current producing the secondary polar action will be so slight that they will be usually ineffective. Under pathological conditions, however, these effects (Ca O and An Cl reaction) may develop. It is also possible that the extreme terminal apparatus of the nerve can alone be stimulated by the galvanic current, and that this always reacts exclusively under the influence of the nearest pole, while the effect of the other virtual pole only occurs at the central end of the nerve, which is perhaps not at all excitable, or at least not with such weak currents.

With the simplest galvanic element (a piece of zinc and copper) placed on the tongue we can produce a peculiar, acid, salty, metallic taste, which, with stronger currents, readily develops upon the application of the electrodes to the cheeks, throat, temples, mastoid processes, and the neck. This is the so-called galvanic taste.

More careful examination—for example, if two medium electrodes be placed upon the cheek—teaches that distinct gustatory sensations occur on both sides, *i.e.*, at both poles, but that they are very different on the two sides. At the An the sensation is more marked and metallic, alkaline, or perhaps very acid; at the Ca it is feebler, more biting, salty, constricting, and never, according to Vintschgau, alkaline. The difference is so striking that the An can readily be distinguished from the Ca by this means.

We also find that the continuous passage of the current is accompanied by a continuous sensation, as the latter is not alone present upon making and breaking the current, but also during its passage, although it rapidly diminishes and disappears with weak currents; when the current is strong, the sensations persist for a long time. Whether these sensations are due to the local action of the alkalies and acids produced by electrolysis, or to the stimulation of the nerves of taste or of their terminal organs, is still undecided.

Very little is known concerning galvanic stimulation of the olfactory nerve. Althaus states that, upon the passage of strong currents into the nasal cavity, he experienced a phosphorus-like smell, and he attributes this to an irritation of the olfactory nerve by the current. Others suppose that this smell is due to the development of ozone (?) in the nasal cavity.

LECTURE VI.

Electro-physiology of the Secretary and Vasomotor Nerves—Cervical Sympathetic—Effect of Electrical Currents on the Skin—Electro-physiology of the Brain and Spinal Cord—Phenomena in Galvanization of the Brain and Spinal Cord in Man—Electro-physiology of the Organs of the Thorax and Abdomen—Electrolytic and Cataphoric Effects—Galvanic Introduction of Drugs into the Body—Remak's Catalytic Effects—Indirect Catalysis.

CONCERNING the electro-physiology of the *secretory nerves* we possess relatively little knowledge which is useful to us. In the human subject very few experiments have been made. It is known that upon passing a galvanic current transversely through the cheeks or the anterior and posterior aural region, in irritation of the acoustic nerve, etc., an active secretion of saliva occurs in the majority of individuals. It is still undecided whether this is due to direct irritation of the chorda tympani or to a reflex stimulation of salivary secretion from irritation of the gustatory nerves or the sensory nerves of the buccal and pharyngeal cavities.

According to Moritz Meyer, the application of the galvanic current in a certain manner to the region of the cervical sympathetic produces a local increase of the secretion of sweat in the corresponding half of the face and the hand; Adamkiewicz states that energetic faradic irritation of the tibial nerve in the popliteal space causes an abundant secretion of sweat in the foot.

No "law of contraction of the *vasomotor nerves*" has yet been discovered but a large number of almost confusing phenomena have been observed. Upon faradic irritation of the vessels, they first contract and then dilate after the cessation of the irritation; if the nerves have been divided for some days their stimulation at once causes dilatation. Upon galvanic irritation with both poles, contraction and then dilatation of the vessels occurs, with stronger currents the dilatation rapidly ensues and predominates. According to Gruetzner, the galvanic current is a direct irritant for certain vascular nerves, viz., the vaso-dilators of the skin; the passage of a constant current for a few minutes through the sciatic nerve of the dog at once produces, independently of the closure or opening of the current, a dilatation of the vessels without previous contraction.

The electro-physiology of the *sympathetic system* will detain us for a few moments, because this has become a matter of prime importance with

regard to certain therapeutic questions ; these remarks refer chiefly to the cervical sympathetic.

This is a very complicated nervous structure, all of whose relations are by no means known, and which is especially shrouded in darkness on account of the interpolation of the large sympathetic ganglia with their problematic functions. It contains the great mass of vasomotor nerves distributed to certain parts ; to the integument of the face and scalp, partly to the brain and eye, perhaps also to the upper extremity ; it also contains fibres which regulate the secretion of perspiration, preside over the dilatation of the pupil and influence the position of the ball of the eye (smooth muscular bundles in the lids and orbits, Mueller's muscle) ; finally, it contains fibres distributed to the heart, and who knows what others.

Physiologists teach us that faradization of the cervical sympathetic causes contraction followed by dilatation of the vessels of the corresponding side of the head and face, increase of the mean cerebral pressure, dilatation of the corresponding pupil and the orbital fissure, slight protrusion of the eyeball, finally acceleration of the action of the heart.

The effect of galvanization of the cervical sympathetic is much slighter and less certain ; many physiologists have not witnessed any effects upon the pupil and the vessels of the scalp, and the statements of others are contradictory.

In the human subject the matter is even more complicated, on the one hand on account of the deep situation of the cervical sympathetic and the difficulty of reaching it, on the other hand, on account of the close proximity of the pneumogastric, the carotid with its vasomotor fibres, the base of the brain, the cervical and brachial plexuses, the cervical region of the spinal cord, etc. The following phenomena have been observed :

Upon faradization of the cervical sympathetic, dilatation of the corresponding pupil (doubtful, because perhaps due to a reflex from the skin), contraction of the vessels, unilateral pallor and coolness, followed by increased warmth.

Upon galvanization of the cervical sympathetic (one pole in the pharynx, the other at the angle of the lower jaw ; or An upon the manubrium sterni, Ca at the angle of the jaw ; or finally, Ca at the angle of the jaw, An at the side of the last cervical vertebra), circulatory changes in the retina and corresponding half of the face and ear ; changes in the pupil, at first dilatation, sometimes followed by contraction ; diminution of the blood-pressure and the frequency of the pulse (doubtful) ; increased warmth and perspiration in the corresponding hand ; a tired feeling and dizziness (very doubtful).

G. Fischer came to the conclusion that the effect of so-called galvanization of the sympathetic is due in great part to the stimulation of the vagus and its branches, and of sensory nerve fibres. But some observations on

pathological cases appear to prove that the cervical sympathetic may be directly influenced by the current; I shall return to this subject at a later period.

We will next turn our attention to the effects of electrical currents upon the *external skin*.

The redness of the skin produced by various applications of the current is undoubtedly caused by dilatation of the blood-vessels.

Upon faradization of the skin with moist electrodes, only insignificant changes occur with a moderate strength of current; with relatively strong currents there is occasionally a temporary pallor of the skin and cutis anserina, which may be followed by more permanent redness. Upon application of the faradic brush the phenomena are more marked; the pallor very rapidly subsides, and is followed by bright redness, which lasts for some time and then disappears without a trace.

Galvanization of the skin, even with a moderate current, will produce (in addition to the pricking and burning sensation previously mentioned) an intense redness at both poles, which may persist for a very long time. Small papules and even broad wheals are not infrequently observed at the point of application and the redness may persist for hours; after repeated applications the epidermis desquamates.

With stronger currents and prolonged duration, it is found that the two poles produce somewhat different effects.

At the cathode you often find, in the beginning, contraction of the vessels and pallor of the skin, followed by a more pale, rosy redness; the skin becomes infiltrated, thickened, covered with wheals, surrounded by a deep red rim; upon opening the current, an intense redness remains for a long time at the site of the electrode.

At the anode, an intense dark scarlet redness occurs at once; the skin does not appear thickened but covered with small elevations; after opening the circuit, the redness continues for a very long time and is followed by desquamation of the epidermis.

If the current is strong, the application of a small metallic Ca to the skin (An in the shape of a large sponge electrode) gives rise to the production of a small vesicle filled with opaque, strongly alkaline fluid; after removal of the electrode this soon dries into a small brown scab, which falls off after a time, leaving a small loss of substance and a permanent, not infrequently pigmented cicatrix. A corresponding anodal application produces comparatively slight effects; the metal electrode is blackened from oxidation, and the wheals which may be present give exit, if pricked, to an acid fluid. If the electrodes are moist and well covered, such phenomena will not ensue. However, there is no doubt that the galvanic current produces very marked changes in the circulation and nutrition of the skin, but the deeper tissues cannot be affected to such a marked extent.

The physiological effects of electrical currents upon the *brain* have been the subject of numerous investigations. Contrary to what happens in the peripheral motor nerves, it has been found that An Cl produces greater stimulation of the cerebral cortex than Ca Cl ; perhaps the cause of this remarkable phenomenon is to be found in the different chemical reactions of the gray and white matter—living peripheral nerve fibres are alkaline (Funke), the gray matter of the brain acid, the white substance neutral or faintly alkaline (Gscheidlen). If the currents are weak or of moderate strength, the shortest possible closure of the circuit will diminish the irritability at the same pole, but increase it at the other; changes of polarity cause most vigorous stimulations. The faradic current is also effective.

Upon performing galvanization of the head, a series of very decided phenomena develop, but faradization of the head in the human subject appears to be devoid of effect.

Vertigo is the earliest and almost constant symptom when galvanization of the head is performed in such a manner that the largest amount of current passes through the brain (transversely through the temples or the mastoid processes, or from the forehead to the back of the neck). This phenomenon consists of a disturbance of equilibrium which is merely of a subjective nature in the mildest grades, but in the higher grades is rendered objective by tottering of the head and trunk so that the individual may even fall; these higher grades may be accompanied by apparent rotatory movements of external objects, or by a sensation of rotation of the body.

It has been ascertained that galvanic vertigo develops with so much more readiness the greater the angle formed by the line connecting both electrodes upon the skull with the sagittal longitudinal diameter; it is therefore most intense when the current is passed transversely, most feeble when passed antero-posteriorly.

Brenner found that, on passing the current transversely, a distinct sensation of vertigo occurs upon closure of the current, together with an objective tottering of the head toward the side of the anode; upon breaking the current, a much slighter degree of tottering toward the side of the cathode. The subjective feeling predominates greatly over the actual amount of tottering.

The sensation of vertigo also continues during the passage of the current. Distinct apparent rotation of surrounding objects is then associated with it, so that the persons experimented on fear that they will lose their equilibrium entirely. These rotations occur usually in a vertical plane, the objects appearing to pass from the side of the anode to that of the cathode, rising upon the former and sinking upon the latter. According to Hitzig, they are due to the ocular movements produced by the galvanic irritation.

The ocular movements probably occur as the result of the severe vertigo and the disturbance of the muscular sense.

If a vigorous current is passed transversely through the mastoid processes, associated, nystagmus-like, oscillating movements of the eyes occur in a definite direction, viz.: in that of the positive current. If the anode is situated on the right side, both eyes will be directed to the left.

In addition, many persons complain, upon galvanization of the head, of a certain dulness, a feeling of confusion, and perhaps of threatening syncope, which may even terminate in syncope in very sensitive individuals. In certain cases a feeling of nausea, and even vomiting, have been noticed.

The results of physiological experiments are much scantier with regard to the spinal cord than the brain. A few authors have investigated the modifying effects of galvanic currents upon the cord. J. Ranke found that the reflex irritability of the spinal cord in the frog could be diminished or entirely extinguished by a current of a certain strength passing through the cord in any direction. Legros and Onimus only found this effect with the descending current, the reflexes being often increased by the ascending current. Finally, Uspensky thinks the spinal cord should be regarded electrically as a peripheral nerve which can be brought into an electrotonic condition by the galvanic current, and he found corresponding changes in the reflex irritability and the respiratory movements.

It has been supposed that the spinal cord of the human subject cannot be reached by electrical currents applied in the ordinary percutaneous method, but this view has been disproven. Large, flat electrodes should be placed on the back, very strong currents employed, and closure and opening should be resorted to. If the Ca is situated on the upper lumbar vertebræ, Ca Cl or change of polarity to Ca will produce vigorous contractions of the muscles supplied by the sciatic nerve, thus proving that the current has penetrated at least into the spinal canal. In addition, numerous undoubted therapeutic experiences teach us that the galvanic current may reach the spinal cord. Nevertheless, our knowledge with regard to the physiological effects of electrical currents upon the spinal cord is almost nil.

Electro-physiological examination has been scarcely directed to the heart and lungs. It has been shown that a certain method of application of the galvanic current will cause movements of coughing, especially if the Ca is placed upon the back of the neck, the other upon the back, and closure of the current or change of polarity is then made; in some persons, also, this will occur if the upper electrode is placed upon the dorsal vertebræ.

We are somewhat better acquainted with the effects of electrical currents upon the abdominal organs.

It has been said that contraction of the gall-bladder, especially in catarrhal jaundice with very dilated gall-bladder, has been obtained by vigorous percutaneous faradization in the region of the organ.

Many observers state that they have succeeded with the faradic current, either directly or in a reflex manner, in effecting a considerable reduction in the size of chronic enlargements of the spleen. Some have faradized the spleen directly by means of moist electrodes, others have employed vigorous irritation of the skin in the splenic region by means of two faradic brushes.

The striated muscular tissue of the pharynx and velum palati may be readily faradized and galvanized by means of suitable electrodes. Local contractions then occur, or, if the currents are strong, vigorous, widespread muscular contractions, movements of deglutition and gagging develop. If the An is placed on the upper part of the back of the neck, and the Ca rapidly passed over the lateral surface of the laryngeal region, you will see and hear a movement of deglutition with every Ca Cl and short labile stimulation (with 6-10 elements). We evidently have to deal here with a reflex process from the sensory nerves of the pharynx and larynx (chiefly the superior laryngeal nerve).

Contraction of the muscular fibres of the œsophagus can also be effected readily by means of electrodes shaped like sounds.

The smooth muscular fibres of the stomach and intestinal tract react to electrical currents by slow contraction, which gradually grow stronger, spread more or less from the site of primary stimulation in a peristaltic manner, and outlast the irritant for a shorter or longer period. They appear to be less affected by the galvanic than by the faradic current.

The effect of vigorous faradization of the abdomen (which can be observed with special distinctness in cases of large inguinal hernia with thin tegumentary coverings, or in persons with very thin, flaccid abdominal walls), consists of the production of visible, palpable peristaltic movements of the stomach and intestines, which sometimes cause gurgling. As an effect of faradization of the stomach, Schliep observed a rapid disappearance from the organ of water which had been introduced; defecation often occurs soon after intestinal faradization. The digestive tract may be reached in various ways: either by percutaneous application, one electrode upon the back, the other stable or slowly moving over the corresponding portion of the abdominal wall, or by means of the introduction of an electrode into the stomach (either a stomach electrode proper or an œsophageal sound to which a wire has been attached), or into the rectum, the other being applied stable or labile upon the external abdominal wall. The electrode, which is introduced internally, causes scarcely any sensation.

Electrical stimulation of the bladder can be readily performed. If a urethral electrode is introduced as far as the neck of the bladder, the contraction of the sphincter vesicæ and urethral muscles upon faradization can be readily detected. Vesical electrization may be done with both currents, either percutaneously or by the introduction of catheter-shaped

vesical electrodes as far as the sphincter or into the bladder. Nothing is known concerning electrization of the other abdominal organs.

I now come to the consideration of the electrolytic and cataphoric effects of electrical currents; this refers almost exclusively to the galvanic current, the effects of the faradic being almost nil in these respects.

The occurrence of electrolytic processes in the animal organism have been distinctly proven with reference to the surface of the body alone, as has been shown on page 52. But concerning the effects produced within the economy, we possess merely surmises. A beginning has been made by Drechsel, who succeeded in producing urea from solutions of carbonate of ammonia by electrolysis with changing currents. It is at least probable that this process also occurs within the living organism. On account of the scantiness of our actual knowledge concerning electrolytic effects in the human subject, I will refrain from theoretical considerations; I will again recur to the subject in considering the therapeutical effects.

Concerning the cataphoric effects we stand on a somewhat more solid foundation. A successful attempt has recently been made to employ the cataphoric action in the introduction of drugs into the body. After v. Bruns had shown that the galvanic current could force iodide of potassium through dead and living parts of the human body, Munk devised the most serviceable method of effecting this object.

The elder Remak had recognized the fact that the chief effects of the galvanic current in disease are very complicated; that we probably have to deal, in the majority of cases, with changes in the nutrition of the parts (molecular, chemical, histological changes). In his studies concerning the curative influence of the galvanic current in inflammations, contusions, hemorrhages, rheumatism, neuritis, etc., it became evident to him that these effects were perhaps direct, from change in the molecular condition, osmosis, etc., of the tissues, but partly also indirect, from changes of circulation and the current of nutritive fluids in the tissues. He has included a number of these effects under the common term catalytic action, viz., dilatation of the blood-vessels and lymphatics, causing more ready circulation of the blood and nutritive fluids, and increased absorption; increased power of imbibition of the tissues, increased osmotic processes and thus increase of volume (especially in the muscles); changes in the disassimilation and nutrition of the nerves on account of their stimulation or sedation; changes in the molecular arrangement of the tissues caused by electrolytic processes; finally, the consequences of the mechanical transport of fluids from one pole to the other.

The physiological or experimental foundation of these catalytic actions is still very imperfect and fragmentary. The conviction of the reality of these changes has forced itself upon almost all electro-therapeutists since the time of Remak, on account of a large array of pathological and therapeutical experiences with which you will become acquainted at a later

period. It would be very desirable, however, if this entire matter were subjected to experimental investigation.

Remak had observed that frogs' muscles, when galvanized by a labile current, showed an enormous congestion, became tenser and appeared swollen, and he maintains that they absorb water much more rapidly than non-galvanized muscles.

Furthermore, the changes described by Remak, Bollinger, v. Ziemssen, and myself after galvanization of the skin are so evident that they have always appeared to me to constitute an important argument in favor of catalytic action.

Of especial importance is the demonstration of the vasomotor effects of electrical currents. The recent experimental researches of Löwenfeld with regard to dilatation and contraction of the cerebral vessels upon transverse and antero-posterior passage of the galvanic current through the head are valuable in this respect.

Perhaps, also, the electrical actions upon trophic nerve-tissues may produce changes in the disassimilation of other tissues and organs of the body, organic metamorphoses, modifications of nutrition, which constitute a part of the "catalytic" effects.

PART III.

METHODS OF ELECTRICAL EXAMINATION AND ELECTRO-DIAGNOSIS.

LECTURE VII.

The Methods of Electrical Examination—Examination of the Motor Nerves and Muscles—Polar Method—General Rules—Method of Quantitative Examination of Irritability with the Faradic and Galvanic Currents—Method of the Qualitative Examination of Irritability—Examination of the Eye—Examination of the Auditory Apparatus—Galvanic Examination of Taste—Examination of Electro-cutaneous Sensibility—Electro-muscular Sensibility.

THE examination of the motor nerves and muscles is by far the most important ; this consists of a carefully measured and graduated stimulation of circumscribed parts, usually situated near the surface, viz., individual nerve-trunks and branches, individual muscles and portions of muscles.

The chief object of examination consists in localizing the current with the necessary intensity and density upon these individual parts, and in keeping other parts as free as possible from their action.

It follows from the laws formulated in Lecture IV. that the polar examination is alone serviceable in examining small parts situated within larger conducting masses.

The following general rules hold good in the polar method of examination in the human subject :

Only one pole may be employed for each irritation ; the effect of the other pole is not excluded, but it should be repressed as much as possible.

The electrode employed for the local irritant effect is called the active or irritant electrode (electrode A) ; the other is the indifferent electrode (electrode B).

The active electrode should be as small as possible, in order to secure the greatest density of current. But this has its limits, especially with regard to the galvanic current ; if the electrode is too small, the strength of

current will be diminished too much on account of the diminution in the transverse section of conduction and the examination thus rendered more difficult; I therefore employ in galvanic examination the "small" or "medium" electrode.

The indifferent electrode should be as large as possible, in order that the density of the current may be as slight as possible and therefore relatively ineffective. This electrode should be applied to the most indifferent position, and the sternum seems to me to be the best in this respect; it is in the median line, the current meets with equal resistance in passing to symmetrical parts of the body, it passes immediately into the trunk and rapidly loses its density; there are no nerves or muscles in the neighborhood whose irritation will interfere with the examination; in addition, the sternum is quite insensible, and the person examined can readily apply the electrode in this position. The indifferent electrode may also be applied to the back of the neck, or the small of the back, but these positions are less serviceable on account of the vicinity of the spinal cord and roots of the spinal nerves in the latter case, and the head and brain in the former. In a few exceptional cases, however, some other localization must be chosen.

One of the most important rules is that the same method of examination should always be employed, and, if possible, the same apparatus, at least when the results of various examinations are to be compared with one another. Every observer should be skilled in the use of his own instruments, and this requires great practice and technical skill.

It is a rule of no slight practical significance, that, in diagnostic investigations, the examination should always begin upon the healthy parts. Inattention to this rule not infrequently causes us to overlook slight disturbances.

METHOD OF THE QUANTITATIVE DETERMINATION OF THE IRRITABILITY OF NERVES AND MUSCLES.

This examination may be made with regard to both forms of current.

The following was the method of faradic examination formerly in general use and also largely employed at the present time; a careful determination was made of the amount of withdrawal of the cylinder at which the minimum muscular contraction occurred (upon irritation of the motor nerves or direct muscular irritation), or the contractions occurring in symmetrical parts were compared with one another, the strength of current remaining the same (equal withdrawal of the cylinder).

This method would be very good if, apart from the variable amount of withdrawal of the cylinder, all the other conditions of the examination remained constant.

But this occurs, as a rule, only in unilateral diseases, upon comparing

perfectly symmetrical parts of one and the same individual. This method is, however, entirely uncertain in bilateral diseases, in which comparison must be made with other healthy individuals. It must be remembered that there are great differences in the resistance to conduction in various individuals (*vide* Lecture III, p. 23).

We must therefore lay down the principle that the resistance to conduction should also be tested ; only when this is found to be similar can we draw any useful conclusions with regard to the presence of differences in the electrical irritability.

In order to free this examination still further from comparison with other individuals, I have endeavored to develop another method of examination.

The purpose of this is to determine the irritability of the nerve-trunks in various parts of the body (head, trunk, upper and lower limbs) and then compare them with one another in healthy persons. In fact, a quite constant relation of the four principal parts of the body was determined, and any considerable deviation of one or another of these pairs of nerves from this relation may be regarded as pathological. It is therefore possible to recognize pathological changes of irritability by the exclusive examination of the patient.

As a matter of course, it was necessary to determine the resistance to conduction in all the parts examined. It was found that this presented quite a constant relation in healthy individuals ; only under the assumption that the relation of the resistance to conduction is approximately normal can the relative values of the irritability be properly estimated. If the relation of the resistances to conduction varies in the same manner as the withdrawal of the cylinder, the conclusions with regard to the irritability become more certain ; if it varies in the opposite manner, the conclusions become more uncertain or may be entirely negated.

The following method should therefore be employed : in the examination the following four nerves or nerve-branches on each side are chosen ; the frontal branches of the facial nerve at the temple (Fig. 28), the spinal accessory nerve in the neck (Fig. 28), the ulnar nerve above the elbow joint (Fig. 29), and the peroneal nerve above the head of the fibula in the popliteal space (Fig. 33). We now determine the amount of withdrawal of the cylinder at which the minimum contraction, *i.e.*, the feeblest distinctly perceptible contraction, is obtained. These numbers are then noted.

With a "medium" electrode, well moistened in warm water, we then determine the amount of deflection of the needle of the galvanometer which occurs with a definite number of elements (10 to 12) and with stable action of the current upon all the localities previously employed for stimulation. I usually employ the Ca for the site of irritation, the An remaining on the sternum. The figures thus obtained are also noted.

We thus obtain two series of figures, one of which represents the relative condition of the faradic irritability of the four pairs of nerves, the other the relative condition of the galvanic resistance to conduction at the corresponding regions of the skin on each side. I have shown above how the results obtained in the second series complement the conclusions drawn from the first series. Both series present a quite constant relation in healthy individuals of approximately similar physique and position in life, and in the same sex. I append two illustrations in healthy individuals:

1. Healthy man ; artisan ; thirty-eight years old :

	Withdrawal of cylinder in millimetres. Minimum contraction.		Deflection of galvanometer, with ten elements, 150 C. R.	
	right	left	right	left
Frontal nerve.....	right 165	left 166	right 18°	left 19°
Spinal accessory nerve ...	right 172	left 177	right 16°	left 15°
Ulnar nerve.....	right 150	left 158	right 6°	left 6°
Peroneal nerve.....	right 160	left 163	right 7°	left 9°

2. Healthy man ; laborer ; twenty-four years old :

Frontal nerve.....	right 195	left 192	right 17°	left 17°
Spinal accessory nerve ...	right 187	left 182	right 10°	left 9°
Ulnar nerve.....	right 175	left 185	right 6°	left 10°
Peroneal nerve.....	right 180	left 180	right 5°	left 5°

These tables are valid for my apparatus alone ; but, although the absolute figures may vary for other apparatus, their relative proportion will not vary.

After having collected a large number of these tables, I have found that the figures are almost exactly the same for both sides of the body, that the four pairs of nerves are irritated by almost the same minimum strength of current, the differences being rarely more than 20-25 mm.

The relation of the resistances to conduction is somewhat different ; the spinal accessory presents less resistance than the ulnar and peroneal, and the frontal nerve still less. There are so many variations in women and children, especially on account of the varying development of the panniculus adiposus, that I do not consider it practicable to determine the normal formula for them. That mentioned above refers to healthy laboring men in middle age.

If the faradic examination of individual nerves is desired, and not a general examination, this is done by careful comparison with the healthy side or with other healthy individuals, all the precautions being taken to

which I have previously referred. In order to prevent mistakes, repeated examinations should be made in all important or doubtful cases.

In quantitative galvanic examination of irritability greater precautions must be observed than in the faradic examination. A statement of the number of elements employed, or the resistance experienced in a rheostat is only sufficient to a certain extent in comparing both halves of the body of one individual; it is useless for comparison with other individuals, on account of the remarkable difference of the resistance to conduction in different persons (Lecture III, p. 23).

The first requisite in the determination of fine quantitative differences is that the nerves and muscles to be compared should be examined with the same density of current. This depends, on the one hand, upon the size and surface of contact of the electrodes, on the other hand, upon the strength of the current. The same electrodes should therefore always be employed in the examination. In addition, the strength of the current should be determined at any period of the examination by means of the galvanometer. If the electrodes are alike, and the strength of the current is accurately determined, we may be certain that if the deflection of the needle be the same, the same density will be present under the active electrode. In addition, the latter should be placed upon the parts to be compared in exactly the same manner and position, and with the same degree of pressure. If, when these conditions are fulfilled, the deflection of the needle necessary to produce a minimum contraction increases, then the irritability is diminished; if the requisite deflection of the needle diminishes, then the irritability is increased.

One of the most important sources of error in this mode of examination is due to the fact that the position of the nerves at the surface of the body is somewhat variable.

The indifferent "large" electrode should be placed upon the sternum, the active "medium" electrode is carefully placed upon the nerve or muscle; we then determine when the first Ca Cl C develops, beginning with a small number of elements; the galvanometer is then introduced and the amount of deflection of the needle noted. The strength of the current is then increased still further, three cathodal closures being made at each stage, until that strength of current is reached at which Ca Cl Te appears; the deflection of the needle and the number of elements is then again noted.

If we have an opportunity for comparison with symmetrical healthy nerves, slight differences of irritability may be determined with great certainty. This is much more difficult when we must institute a comparison with other individuals. In order to avoid this as much as possible, we may examine the four pairs of nerves of different parts of the body, as has been previously explained with regard to the faradic current. The following table will serve as an illustration of the results thus obtained:

Healthy man ; artisan, thirty-eight years old :

Nerve,	Appearance of first Ca Cl C with	Appearance of first Ca D C > (Tet.) with
Right frontal nerve.....	8 elements 16°	12 elements 32°
Left frontal nerve.....	6 " 18°	10 " 29°
Right accessory nerve.....	6 " 7°	12 " 29°
Left accessory nerve.....	6 " 8°	12 " 31°
Right ulnar nerve.....	6 " 5°	14 " 28°
Left ulnar nerve.....	6 " 5°	14 " 27°
Right peroneal nerve.....	8 " 7°	14 " 29°
Left peroneal nerve.....	8 " 8°	12 " 28°

The frontal nerve, however, presents a very variable relation, and I therefore think it more practical to exclude it, as a rule, from the examination.

The strength of current at which An Cl C, An O C and Ca O C develop in the various nerves may be examined in a similar manner.

In addition to the quantitative examination of the irritability, you should also ascertain whether any anomalies of the law of contraction, etc., are present. I will therefore add a few words with regard to the

METHOD OF THE QUALITATIVE DETERMINATION OF THE IRRITABILITY OF THE NERVES AND MUSCLES.

No qualitative determination of irritability with the faradic current has yet been obtained. This examination with the galvanic current plays a prominent part in electro-diagnosis.

The question with which we have to deal is the determination of the law of contraction of each individual nerve or muscle ; we must observe whether the contractions appear in the proper manner, present the ordinary strength, and are unchanged in form and duration. In general the same method is to be employed as in the determination of the law of contraction, *i.e.*, the polar method, with the previously mentioned precautions. It is especially important that you should be well informed with regard to the peculiarities of each nerve of the body, as these may deceive the beginner. Especially important with regard to the muscles is the examination of the mode of contraction, its rapid or slow occurrence, the predominance of one or the other factor of irritation. In doubtful cases it is well to compare the corresponding muscle of healthy individuals.

METHOD OF EXAMINATION OF THE EYE.

The polar method is strictly employed, the active "medium" or "small" electrode being placed upon the closed lids (or upon the temple

or forehead), the indifferent "large" electrode closing the circuit upon the sternum. It has also appeared to me to be useful to apply the indifferent electrode upon the back of the neck. The examination of each eye is then made in the usual manner with regard to Ca Cl and Ca O, An Cl and An O. Four, six, or, at the most, eight elements are usually sufficient. The examination is rendered easier if made in a half-darkened room, the eyes being kept closed.

On account of the very great irritability of the retina it is often difficult in cases of unilateral disease to prevent the diffusion of the current to the other eye. In such cases the indifferent electrode should be applied as a "small" electrode to the corresponding temple, the irritant electrode (also "small") to the closed lid.

METHOD OF EXAMINATION OF THE EAR.

Brenner first employed the polar method of examination which I have previously described. I have changed this method somewhat; the irritant electrode, a "medium" well-moistened one, is applied directly in front of the ear so that it covers the entire tragus and presses it slightly inward without occluding entirely the auditory canal. The indifferent electrode may be applied to the sternum; nor is it inadvisable to apply it to the hand of the same side. We will effect our object most readily, however, by applying it to the back of the neck, partly on account of the slight resistance to conduction at this place, partly on account of the more favorable direction of the densest threads of current. I have previously explained in detail the manner in which the examination should be conducted.

Patience and considerable practice are essential requisites; repeated sittings are often necessary to accustom the patients to the various disagreeable auxiliary effects. We should begin with weak currents and increase the strength very gradually; the occurrence of Ca Cl reaction is especially facilitated if we have previously allowed Ca D to act; the more rapidly Ca Cl and An O follow one another, the more actively will Ca Cl act. The production of An O reaction is facilitated by long duration of closure; it is most readily obtained if we gradually increase to the greatest strength of current tolerated during An D and then suddenly open the circuit.

METHOD OF EXAMINATION OF TASTE.

The poles may be placed upon the cheeks and the current allowed to pass transversely through the buccal cavity; the person experimented upon should then describe the sensations of taste occurring upon the two sides. The polar method is also useful for more localized examination. A

"fine" sponge electrode, provided with an interruptor, is placed upon various parts of the tongue, pharynx, cheek, etc., and Ca Cl and Ca D, An Cl and An D then tested.

Neumann has devised a serviceable method of examination; the two well-isolated pole wires are fastened to an elastic catheter or a glass rod in such a manner that both ends, which are provided with small buttons, project at a distance of 2 to 3 mm. from one another. Armed with one or two elements this double electrode serves admirably to carefully localize the sensations.

ELECTRICAL EXAMINATION OF THE SENSIBILITY OF THE SKIN.

It has not always been borne in mind that the application of electrical currents to the skin tests two factors; first, the electrical irritability of the nerves of the skin and their terminal organs, *i.e.*, the law of sensory contraction; secondly, the reaction of the skin as a sensory organ to the electrical irritant, which produces a specific sensation.

It is a question whether it is justifiable to test the "absolute sensitiveness" of the skin by means of electricity, and to employ this as a measure of the degree of its sensorial irritability. The skin, regarded as a sensory organ, cannot be tested with irritants other than those adequate to it, *viz.*, touch, pressure, various temperatures, and the higher grades of these irritants which produce pain; it may be disputed whether electricity should be included among these "adequate" irritants of the skin. In fact, the electrical sensation is a specific, distinct quality of tegumentary sensibility, whose careful examination, however, is of value in many morbid conditions.

I have previously shown (Lecture VI., page 44) how the electrical irritability of the nerves of the skin and their terminations can be tested with the faradic and galvanic currents.

The attempt has been made to recognize finer disturbances of sensation, chiefly by means of the faradic current.

Leyden first described such a method; by means of two blunt points of a compass, which are situated one centimetre from one another, the secondary faradic current is introduced into the skin, and then the withdrawal of the cylinder, at which a minimum electrical sensation occurs at various parts of the surface of the body, is determined. From the series of figures which he thus obtained Leyden drew the conclusion that the absolute sensibility presents but moderate differences at various parts of the surface of the body.

Upon employing this method, however, I have by no means obtained such a smooth series of figures as Leyden, and this fact appears to me to be due to faults in the method itself. Slight moisture of the skin, perspiration, etc., cause the results to vary; and finally, the resistance to

conduction has been entirely overlooked. I have long since discarded this method as unpracticable; and I may say the same of Bernhardt's plan of testing the sensation to pain with the galvanic current.

I have, therefore, endeavored to devise a more serviceable method of testing the farado-cutaneous sensibility.

Electrode B, large and moist, is always placed upon the sternum. I employ an irritant electrode, which, like the brush, has the advantage of numerous points of entrance of the current into the skin, but avoids the disadvantage of the mechanical action of the individual threads of the brush. A bundle of more than four hundred fine, insulated, and varnished metal wires are enclosed in a hard rubber tube about two centimetres in diameter, firmly adherent at one end to the handle of an electrode (Fig. 20, *a*); the other free end is as smooth as possible, so that it produces the sensation of a perfectly smooth metallic surface upon being placed on the skin. Upon being applied to the surface, this covers a circle of skin two centimetres in diameter, into which about four hundred threads of current enter at the same time. We thus exclude all possible sources of error (sweat-ducts, hair-follicles, small nerve-twigs, etc.) and are independent of slight changes in the position of the irritated spot.

This electrode (connected with the Ca of the opening current) is then applied with moderate firmness to the integument; the cylinder being now gradually withdrawn, we ascertain its position when the first minimum electrical sensation occurs; the cylinder is then withdrawn more rapidly until the individual experiences a distinct sensation of pain, and the amount of withdrawal of the cylinder is again noted.

The examination is then repeated upon as many parts of the body as is desired. In addition, it appears to me to be necessary to determine the resistance of the skin to galvanic conduction, in order to be able to control the results of the examination due to deviations in the former. Numerous experiments on healthy persons give approximately the following average figures for the various parts of the body. (See Table, p. 68.)

Very little remains to be said with regard to the examination of the electro-muscular sensibility. Of late this has almost fallen into oblivion, and it is certainly by no means so readily tested as is often supposed.

The examination is made by causing more or less vigorous contractions of the individual muscles with the faradic current, by irritation of

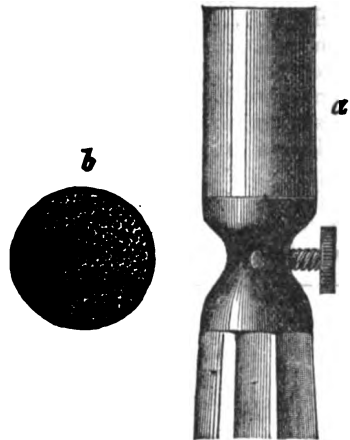

FIG. 20.—Electrode for examination of farado-cutaneous sensibility. *a*, hard rubber tube; *b*, free surface of the electrode.

their nerve-trunks or motor points, and then directing attention to the sensation of tension and contraction, increasing to pain, which occurs in the muscles. On account of the coincident irritation of the sensory nerves and the skin it is not always easy to distinctly recognize this sensation; the examination is therefore certain and simple in those cases alone in which anaesthesia of the skin is present.

Point of irritation.	Minimum.	Pain.	Deflection of needle with 8 El. 150 C. R.
Cheek.....	200-220	130	26°
Neck.....	180-200	120	22°
Arm.....	200	120	21°
Forearm.....	190	115	18°
Dorsum of hand.....	175	110	15°
Tips of fingers.....	125	90	2°
Abdomen.....	190	120	20°
Thigh.....	180	115	21°
Calf.....	170	110	19°
Dorsum of foot.....	175	110	10°
Sole of foot.....	110	80	5°

LECTURE VIII.

Pathological Changes of Electrical Irritability and their Diagnostic Significance—A. Electro-diagnosis of the Motor Nerves and Muscles—1. Increase—2. Diminution of Electrical Irritability—3. Degeneration Reaction—Description of De R.—Its Course—Increased Mechanical Irritability.

A. CHANGES IN THE ELECTRICAL IRRITABILITY OF THE MOTOR NERVES AND MUSCLES.

BOTH quantitative and qualitative changes occur, the latter especially in the muscles, and rarely without the coincident occurrence of the former. The reaction of the nerves and muscles to the faradic and galvanic current is parallel in many cases, in others it is totally divergent.

1. INCREASE OF ELECTRICAL IRRITABILITY.

The pathological increase of irritability, with regard to faradic examination, is characterized by a more ready reaction of the nerves and muscles to the current; by an increase in the amount of withdrawal of the cylinder at which the minimum contraction occurs, or by increased intensity of the contraction occurring upon equal withdrawal of the cylinder. The following table illustrates increased faradic irritability of the peroneal nerves in a relatively recent case of ataxia :

	Withdrawal of cylinder in millimetres. Minimum contraction.		Deflection of galvanometer, ten elements. 150 C. R.	
Frontal nerve	right 170	left 168	right 24°	left 24°
Spinal accessory nerve	right 166	left 167	right 17°	left 18°
Ulnar nerve	right 170	left 165	right 6°	left 6°
Peroneal nerve	right 205	left 200	right 7°	left 8°

The results are still more evident if the increase of irritability is unilateral.

With regard to the galvanic current, simple increase of irritability is characterized by the occurrence of the first Ca Cl C, with a less strength of current; the rapid transition of Ca Cl C, with a slight increase in the

strength of current, into Ca D C (tetanus) ; very early appearance of An O C ; finally, the occurrence of An O Te as the highest degree of intensity.

In many cases the increased irritability is distinctly shown by a striking disproportion between the motor and sensory reaction, *i.e.*, very vigorous contraction with very slight sensation and without any pain. In simple increase of irritability qualitative changes of importance are absent.

A case of tetany, in which the following results were obtained, will serve as an illustration :

In the radial nerve :

First Ca Cl C with $\frac{1}{2}^{\circ}$ deflection of needle (normally, 3°).

First Ca D C with 3° deflection of needle (normally, 10°).

In the ulnar nerve :

First Ca Cl C with $\frac{1}{4}^{\circ}$ deflection of needle (normally, 6°).

First Ca D C with $3\frac{1}{2}^{\circ}$ deflection of needle (normally, $10-11^{\circ}$).

In this patient An O tetanus was obtained with fourteen elements ; in a healthy individual, with a similar resistance to conduction, this cannot be produced with 24 to 26 elements.

The determination of these quantitative changes of irritability occurs with the greatest facility in unilateral affections, in which a comparison may be made with the corresponding healthy parts ; when this is not the case, the directions previously laid down for exact quantitative determination of irritability hold good. Such changes can then be readily and positively ascertained.

Occurrence.—Simple increase of electrical irritability is, on the whole, a rare phenomenon, and possesses no great diagnostic importance ; perhaps it would be found more frequently if a careful quantitative examination were more often made.

It has been observed, in a moderate degree, in some forms of cerebral paralysis, in hemiplegias of various kinds and not too long standing, especially in those associated with motor-irritative symptoms (contractures) ; more rarely in some spinal affections, for example, in the initial stage of locomotor ataxia, perhaps also in some nerves in recent cases of progressive muscular atrophy ; but all these statements require more careful investigation. Finally, it is somewhat more frequent in certain forms of peripheral paralysis, usually only for a short period at the beginning, though sometimes for a longer time ; for example, in recent cases of rheumatic facial paralysis (Erb, Brenner, Beyer), also in paralysis of the radial nerve from compression (Bernhardt), and in recent neuritis.

But the occurrence of increased electrical irritability is more interesting and important in certain forms of spasm. I first demonstrated this in a case of tetany, in which the occurrence of An O tetanus was especially well marked. I have since observed this condition in all cases of tetany which have come under my notice, and this has been corroborated by other observers. In my first cases the increased irritability was confined

to the nerves of the trunk and extremities, but others have also found it in the facial nerve. It is also said to occur in recent cases of chorea minor, but I have not succeeded hitherto in verifying this statement.

2. DIMINUTION OF ELECTRICAL IRRITABILITY.

With regard to the faradic current, this is characterized by a diminution in the amount of withdrawal of the cylinder necessary to the production of a minimum contraction, or by a distinctly feebler character of the contractions with stronger currents; the diminution of irritability may increase so that progressively stronger currents are required to produce contraction. If the strongest currents which can be employed produce no contraction we speak of "the extinction of faradic excitability." Strictly speaking, this is at first true of percutaneous stimulation alone; feeble contractions can often be produced for a long time in the exposed muscles, or by means of electro-puncture. It is especially evident in unilateral diseases when a comparison can be made with symmetrical parts. The following will serve as illustrations:

1. *Progressive muscular atrophy*, most marked on one side:

	Healthy side.	Diseased side.
Ulnar nerve	130 mm.	110 mm.
Median nerve	155 "	138 "
Peroneal nerve	140 "	105 "

C R the same on both sides.

2. *Case of true muscular hypertrophy of the left leg.* (O. Berger, Case

I.) Diminution of faradic muscular irritability:

Quadriceps	right, 95 mm. ; left, 50 mm.
Vastus externus	" 100 " " 35 "
Gastrocnemius	" 87 " " 15 "
Tibialis anticus	" 105 " " 55 "

But even moderate diminution of faradic irritability may also be determined in bilateral affections.

3. *Case of locomotor ataxia ; man aged thirty-seven years :*

Frontal nerve	right, 170 mm. ; left, 165 mm. ; 10° C R.
Spinal accessory nerve	" 175 " " 180 " 8° "
Ulnar nerve	" 175 " " 185 " 2° "
Peroneal nerve	" 132 " " 142 " 1½° "

Therefore diminution of faradic irritability in the peroneal nerves.

In some cases, also, the diminution of faradic irritability is very evident in different parts of the same nerve, for example, in the nerves of the arm at the elbow compared with the wrist. Thus, for example, in progressive muscular atrophy:

	At the elbow.	At the wrist.
Median nerve	168 mm.	113 mm.
Ulnar nerve	165 "	123 "

In another case I obtained the following results :

	At the elbow.	At the wrist.
Median nerve	155 mm.	Extinguished.
Ulnar nerve.....	176 "	"

It is self-evident that we cannot conclude positively that the same fibres are irritable at the elbow, but non-irritable at the wrist, although such a condition is possible. In many cases we may only conclude that the central portion still contains a number of irritable fibres, but the peripheral part does not. Which of these two interpretations is correct will be ascertained by careful observation of the muscles which are to be contracted.

With regard to the galvanic current, diminution of excitability is first expressed by the occurrence of the minimum Ca Cl C with a greater strength of current ; a disproportionately great strength of current is necessary to produce Ca Cl Te ; finally the reactions gradually disappear ; at first Ca O C is no longer possible, then An Cl C and An O C diminish and disappear ; very soon Ca D C can no longer be produced, so that finally Ca Cl C alone remains with a very great strength of current. If this can no longer be obtained (even with a change of polarity) we speak of extinction of galvanic irritability.

This is the usual course of events in simple diminution of galvanic irritability in the nerves ; there are no qualitative changes of the law of contraction or the mode of contraction. The latter is always short and lightning like, not slow and long drawn out. This is also true of the muscles, but only in a portion of the cases ; in another part, qualitative changes also occur. Then the extinction of the contractions follows a different order, finally An Cl C alone remains and the contractions are slow and long drawn. But this forms part of the degeneration reaction, which will soon engage our attention.

I will first give a few examples of unilateral affection of the nerves and muscles :

1. Pressure paralysis of the right radial nerve (middle form) :

First Ca Cl C : right at 22° ; left at 10° deflection of needle.

First Ca D C : right at 34° ; left at 31° deflection of needle.

2. Atrophy of left quadriceps from inflammation of knee-joint (Rumpf) :

Crural nerve	{	Ca Cl C : right, 4° ; left, 7°
		An Cl C : " 5° " 12°
		An O C : " 31° " 37°

3. Encephalopathy ; left hemiparesis :

Ulnar nerve.....	{	Ca Cl C : right, 8 EL., 6° ; left, 10 EL., 15°.
		Ca D C : " 14 EL., 28° ; " 18 EL., 36°.
Peroneal nerve...	{	Ca Cl C : " 4 EL., 3° ; " 10 EL., 19°.
		Ca D C : " 10 EL., 26° ; " 18 EL., 38°.

Thorough examination also gives satisfactory results in bilateral diseases.

1. Locomotor ataxia :

Ulnar nerve Ca Cl C, 6° ; Ca D C, 30°.
 Peroneal nerve Ca Cl C, 20° ; Ca D C, 40°.

2. Spastic spinal paralysis ; man aged thirty-five years :

Right frontal nerve Ca Cl C, 10°.
 Right spinal accessory nerve .. Ca Cl C, 4° ; Ca D C, 35°.
 Right ulnar nerve Ca Cl C, 2° ; Ca D C, 36°.
 Left ulnar nerve Ca Cl C, 3° ; Ca D C, 35°.
 Right peroneal nerve Ca Cl C, 17° ; Ca D C, 41°.
 Left peroneal nerve Ca Cl C, 23° ; Ca D C, 45°.

These two cases show diminution of galvanic irritability in the peroneal nerves alone.

Occurrence.—Simple diminution of electrical irritability occurs very rarely in cerebral paralyzes and only in a very slight degree ; at all events, it only occurs in such cases, as a rule, after the disease has lasted for many years, and the integrity of the electrical irritability is justly regarded as characteristic to a certain extent of cerebral paralysis and as a valuable aid in diagnosis.

In bulbar paralyzes (especially chronic progressive bulbar paralysis) diminution occurs frequently in the nerves as well as in the muscles ; the latter often present the degeneration reaction.

In certain spinal affections a simple diminution of electrical irritability is not infrequently observed ; thus, to a moderate degree in old cases of locomotor ataxia, in spastic spinal paralysis, in cases of chronic myelitis and multiple sclerosis, in the spinal affections of general paresis, in unilateral spinal lesions upon the paralyzed side, etc. Even higher grades of diminution are sometimes observed in connection with the simple atrophy of muscles, which is due to their inaction.

Perhaps this also includes the cases of acute ascending paralysis, acute myelitis, and other spinal affections in which a rapid and marked decrease of faradic and galvanic irritability has been observed.

In progressive muscular atrophy, simple diminution of electrical irritability in the nerves and a large part of the muscles can generally be alone determined, especially in those obscure forms which begin in early childhood and drag their weary course for years ; in the typical form, on the other hand, degeneration reaction is found in a portion of the muscles.

In peripheral affections it must be remembered that those parts of the nerve situated centrally from the lesion cease, upon the occurrence of paralysis, to be open to examination, *i.e.*, they appear inexcitable under all circumstances, because they are deprived of connection with the muscles to which they are distributed, and can therefore not manifest their irrita-

bility. It is characteristic of peripheral paralysis that the portion of the nerve situated on the proximal side of the lesion is entirely inexcitable to the faradic and galvanic currents, and this can be often employed to secure more accurate localization of the cause of the paralysis.

You must be very cautious in assuming a simple diminution of electrical irritability in the peripheral portion of the nerve ; as a rule, it occurs only as a part-symptom of the degeneration reaction, which is manifested in the nerve as diminution progressing to complete extinction of the faradic and galvanic irritability ; in the muscles, on the other hand, as diminution and loss of faradic irritability, while the galvanic excitability passes through an entire series of quantitative and qualitative changes, terminating in complete extinction. In rare cases of certain peripheral paralysis, however, simple diminution of electrical irritability has been alone observed.

In an entire series of diseases of the muscles, also, their electrical irritability is simply diminished to a greater or less extent without any qualitative changes. This occurs, as a rule, in the rare cases of true muscular hypertrophy, and to a still greater extent in so-called pseudo-hypertrophy of the muscles, in which the greatly diminished electrical irritability stands in striking contrast to the colossal size of the muscles. But practically and diagnostically this is much more important in the very frequent atrophy and paralysis of the muscles as a result of joint diseases (shoulder, knee, etc.). Qualitative changes of paralysis are always absent in such cases, and this is very important in the differentiation from degenerative atrophy.

Seeligmueller has recently described some cases of arsenic paralysis, in which the faradic and galvanic irritability was very markedly diminished without any degeneration reaction. Da Costa* makes a similar statement. We not infrequently meet with cases of old paralysis, atrophy etc., in which examination merely shows more or less diminution of irritability ; but it is then difficult or impossible to decide whether we do not have to deal with the terminal stage of the degeneration reaction.

At all events, the diminution of electrical irritability possesses a certain diagnostic significance, and especially the slighter grades appear capable of facilitating the diagnosis of certain (particularly central, spinal) affections, of excluding simulation, etc. In several medico-legal cases I have thus succeeded, by a careful quantitative electrical examination, in determining the almost solitary positive fact which indicated the actual existence of disease, and thus securing justice to the patient.

5. THE DEGENERATION REACTION (DE R).

Under this term, which was first employed by me, is understood an entire cycle of quantitative-qualitative changes of irritability, which occurs in the nerves and muscles under certain pathological conditions, and presents intimate relations to certain histological degenerative changes occurring in

these structures. It is characterized in the main by diminution and loss of the faradic and galvanic irritability of the nerves, and the faradic irritability of the muscles, while the galvanic irritability of the muscles persists, is sometimes considerably increased, and is always changed qualitatively in a definite manner.

Clinical observation teaches that the De R is not always completely developed, but that there are also cases in which it is, so to speak, restricted to the muscles, the nerves being more or less spared (partial De R). I will first give a detailed description of the complete De R.

The most important fact is that the course of the changes in the irritability of the nerves and muscles is entirely different.

After the action of a paralyzing lesion the motor nerves present, in rare cases, a slight increase of electrical irritability, which continues for a short time (one to two days); as a rule, however, a continuous diminution of the faradic and galvanic excitability begins immediately or very soon after the development of paralysis (second or third day). It is completely extinguished by the end of the first week or during the second, so that, at least by percutaneous stimulation, no contraction can be produced by the strongest faradic and galvanic currents. The diminution begins at that portion of the nerve situated nearest to the lesion, and spreads quite rapidly toward the periphery. In this respect the nerve reacts almost entirely alike to both forms of current.

This absolute inexcitability continues for a variable period; for a very short time in mild cases, for many weeks and months in obstinate cases, and permanently in incurable ones.

Then the first traces of returning irritability to both currents appear at the same time, when the restoration of the lesion and the regeneration of the nerves have progressed to a certain extent. These traces are first observed in that portion of the nerve situated next to the lesion, progress very gradually toward the periphery and increase very gradually; this holds good for both currents alike. In severe cases the irritability remains less than normal for a more or less protracted period, and, in such cases, voluntary motion is sometimes completely restored, while the electrical irritability of the nerves still presents an undoubted diminution.

In such cases you may usually notice that the inexcitability of the nerves continues at a period when voluntary movements can be produced, *i.e.*, a return of mobility, despite continuous loss of electrical irritability, and that the increase of voluntary motion occurs more rapidly than that of the electrical irritability. This simply indicates that the nerve will conduct the stimulus of the will, but is not excitable by the electrical currents.

This striking phenomenon is explained by the fact that the conductivity and electrical irritability of the nerves are two separate qualities. As soon as the central and peripheral parts of the nerve have reunited at the site of lesion, and a certain stage of regeneration has appeared in the

peripheral portion, the motor paths are capable of conduction, but they are not yet excitable by electrical currents; for this purpose the regeneration must have proceeded farther. If, in the accompanying illustration (Fig. 21) of such a motor nerve, the site of lesion situated between *b* and *c* has been regenerated, a conduction of the stimulus coming from *a* to the muscle is again possible, although the part below *c* is still electrically inexcitable. If the electrical stimulus is applied below *c* no contraction follows, if applied above *b* distinct contractions follow; as the stimulus of the will acts above *b*, it will also give rise to muscular contractions.



FIG. 21.

The reaction of the muscles in De R is entirely different from that of the nerves.

The muscle reacts almost exactly like the nerve to the faradic current; a progressive diminution of irritability ensues, and terminates in complete extinction during the course of the second week. As in the nerves, this extinction of faradic excitability continues for a longer or shorter period and then slowly returns to the normal, though somewhat later than in the nerves.

The reaction to the galvanic current is entirely different. During the first week there is a moderate diminution of galvanic irritability, but during the course and toward the end of the second week an increase occurs which may reach a considerable intensity in the next few weeks, and is combined with qualitative changes in the formula of contraction as well as its manner.

The increase of galvanic irritability becomes evident very rapidly; finally, distinct reaction on closure and opening may be obtained with eight, six, four, even two elements with a strength of current which scarcely influences the needle of the galvanometer. With this increase of irritability a progressive change in the mode of contraction also begins; instead of the normal, short, lightning-like contraction, a slow, long-drawn contraction occurs, which passes into continuous tetanus, lasting during the entire duration of the current with relatively feeble currents. I regard the slowness of contraction as especially characteristic of the De R, and it is present under all circumstances.

Not less striking than this change in the mode of contraction is the coexisting qualitative change in the law of contraction of the muscle. This is chiefly caused by the more marked increase of An Cl C; this soon becomes as great as Ca Cl C (An Cl C = Ca Cl C), and in most cases becomes considerably greater (An Cl C > Ca Cl C); next to the slowness of contraction this is a very important characteristic of the De R.

This condition is made evident by the adjoining curves, which show only closure contractions.

What is true of An Cl also holds good with regard to Ca O C; this increases with greater relative rapidity than An O C, and soon equals it, though we rarely find $\text{Ca O C} > \text{An O C}$. However, I have repeatedly observed the latter condition.

This condition—*increase and qualitative change of galvanic irritability*—continues unchanged for a variable period (three to eight weeks).

A gradual diminution of the galvanic irritability then occurs, while the qualitative changes, especially the slowness of the contractions, continue uninterrupted; greater strengths of currents are gradually required to

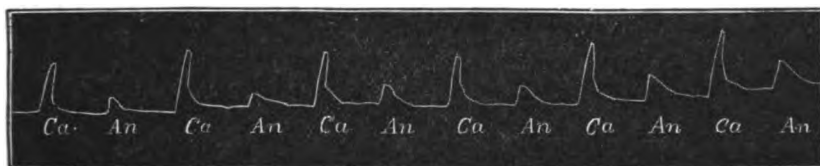

1.

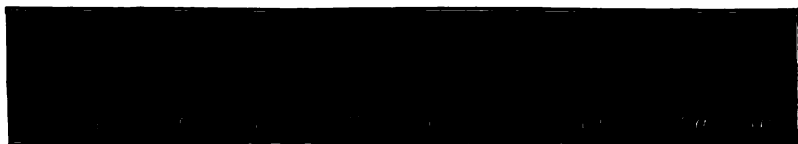

2.



3.

FIG. 22.—Curves of closure contractions in direct (unipolar) stimulation of the muscles in the distribution of the peroneal in the leg; Ca = Ca Cl C; An = An Cl C. 1. Curve in a healthy girl, 33 elements; Ca Cl C considerably greater than An Cl C. 2. Case of chronic anterior poliomyelitis, De R. Curve in the peroneal distribution, 38 elements; An Cl C much greater than Ca Cl C. 3. The same case, with 40 elements; predominance of An Cl C and slow character of the contractions very marked.

produce the slow contractions. In incurable cases the diminution of irritability increases more and more; finally Ca Cl C disappears entirely and a feeble An Cl C remains as the last trace of vitality in the muscular fibres. Years may elapse before the galvanic irritability of the degenerated muscle has entirely disappeared.

In curable cases, however, the normal conditions gradually return in the muscles, and with more or less rapidity according as the regeneration occurs sooner or later. But you should never expect that the normal condition will be restored forthwith in the muscles, with the return of conduction and irritability in the nerves; the changes in the muscle require some time for their retrogression, and it may therefore happen that qualitatively normal contractions are obtained for some time through the nerves, although the qualitatively abnormal contractions of the De R are still visible upon direct irritation of the muscles. The normal reaction returns

very gradually ; as a rule, however, the irritability remains below the normal for a considerable period after the restoration of mobility.

Neumann has discovered that the striking difference in the faradic and galvanic excitability of the muscles is due to the physical difference between the two currents. He ascertained that in such pathological cases, currents of a certain duration are alone capable of stimulating the changed muscles ; as the faradic currents are of mere momentary duration, they remain without effect upon the diseased muscles. If, by any means, the galvanic current is made of very short duration, it also remains entirely ineffective. But why the degenerated muscles lose the capacity of reaction to currents of very short duration remains to be discovered ; it is probably due, in great part, to the chemical and molecular changes in the contractile substance.

The increased mechanical irritability of the muscles also stands in close relation to these changes. It is observed more or less distinctly in all cases of this kind and is characterized by the occurrence of a very distinct but slow contraction upon all kinds of mechanical irritants (best upon slight, sudden tapping with a percussion hammer or the finger, upon simple pressure, or even rapid removal of a compressing body). This symptom usually appears somewhat later and disappears earlier than the increase of galvanic irritability, but is often observed for weeks and months.

LECTURE IX.

3. Degeneration Reaction (*continued*)—Its Relation to Degenerative Atrophy of the Motor Nerves and the Muscles. Their Description · Comparison of their Course with that of the De R—Complete and Partial Degeneration Reaction—Occurrence of the De R—Diagnostic Conclusions therefrom—Its Prognostic Significance—Special and Critical Remarks.

It has been established beyond a doubt that the phenomena of the De R possess intimate relations with certain histological changes in the nerves and muscles.

They are the phenomena of degenerative atrophy of the motor nerves and muscles, of which the changes occurring after experimental section or compression of the nerves may be regarded as a type.

The first result of such a traumatic lesion is the degeneration of the peripheral portion of the nerve. Within a few (two to four) days the medullary sheath coagulates and breaks up into clumps, drops, granules, a process which spreads quite rapidly and leads to the formation of masses of granules and granular corpuscles. This is associated with softening, degeneration, and destruction of the axis cylinder, together with marked proliferation of the nuclei in the sheath of Schwann. Gradually a large part of the products of degeneration is absorbed and the sheath of Schwann merely contains a homogeneous protoplasmic mass. This process spreads very rapidly from the site of the lesion toward the periphery into the finest ramifications of the nerves.

These appearances are also associated with changes in the neurilemma ; apart from the circumscribed traumatic neuritis at the site of lesion, an increase of the nuclei in the sheath of Schwann occurs in the entire peripheral portion of the nerve, together with a considerable accumulation of cellular elements in the endoneurium and perineurium ; these become transformed into spindle cells and connective tissue, which increases to a marked extent, forces itself in broad bands between the individual bundles of nerve-fibres and into the latter themselves, leading finally to cirrhosis of the nerves. How this hyperplasia of the connective tissue occurs is a question ; whether from the irritation produced by the products of degeneration of the nerves or from paralysis of vasomotor and trophic fibres is still undecided.

After a shorter or longer period, according to the form and severity of

the lesion, more or less complete regeneration of the nerve occurs. The unsettled question as to the manner in which this is effected may be left to the histologists. To us as electro-therapeutists it is sufficient to know that it does occur.

Parallel with the changes in the nerves are analogous histological changes in the muscles supplied by them. The first phenomenon noticeable is a progressive diminution in the size of the muscular fibres, which becomes distinct during the second week, is very considerable after the lapse of a few weeks, and, in incurable cases, leads to complete disappearance of the fibres. The transverse striation becomes somewhat indistinct, but fatty or granular degeneration of the fibres is observed only exceptionally. A considerable increase in the number of the muscle nuclei, which are accumulated in masses and chains, occurs at the same time; finally a chemical change in the muscular substance develops and is manifested by the greater tendency of these muscles to the development of so-called waxy degeneration.

Cellular infiltration and connective tissue proliferation in the interstitial connective tissue of the muscles also occur, and the terminal result is an evident cirrhosis of the muscle, whose atrophic and small fibres appear surrounded, after the lapse of a few weeks, by large tough bands of fibrous tissue. In incurable cases the entire muscle is transformed into connective tissue, which may afterward become the seat of a deposit of fat.

As soon as the regeneration of the nerves occurs, the muscle is slowly restored to its normal condition, though this requires a long time. Experimental and clinical investigations have proven that these degenerative changes are the main cause of the De R.

The degeneration of the peripheral portion of the nerve corresponds exactly in point of time to the diminution and extinction of its faradic and galvanic excitability, and is undoubtedly the cause thereof. With the regeneration of the nerve begins the return of the excitability of its peripheral portion. But the electrical irritability reappears somewhat later than the conductivity of the nerve-fibres for voluntary impulses or for electrical irritation applied to the central portion. This seems to depend upon the stage of development of the regenerated fibres; they do not appear to become excitable until they are provided with a medullary sheath of a certain width, while they are capable of conduction at an earlier stage. With the increasing development of young fibres the irritability increases but it remains below the normal for some time, partly on account of the insufficient development of nerve-fibres and the cirrhosis of the nerves, to a still greater extent on account of the atrophy and cirrhosis of the muscles, which do not respond with normal vigor to stimulation proceeding from the nerves.

The degeneration of the intramuscular nerves is the cause of the depression of their faradic and galvanic excitability during the first week, as

no changes are noticeable at this time in the muscular fibres themselves. The chemico-histological alterations of the transversely striated substance are undoubtedly the cause of their inexcitability to the short faradic

1. Paralysis with relatively early return of motion.

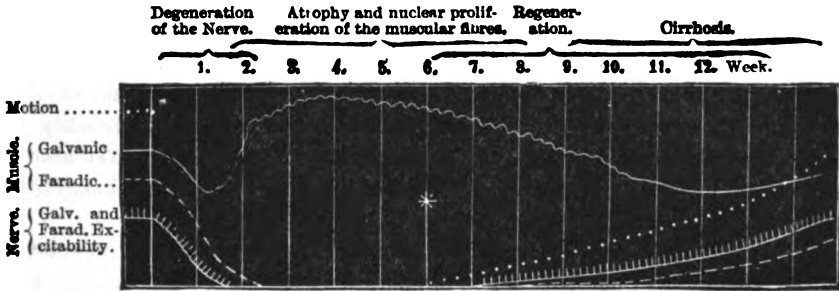

2. Paralysis with late return of motion.

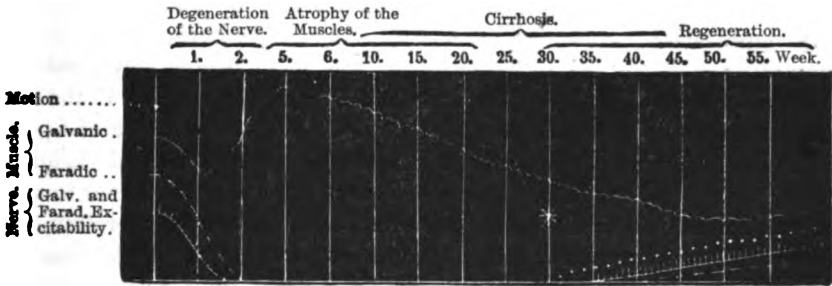

3. Incurable paralysis. Motion lost permanently.

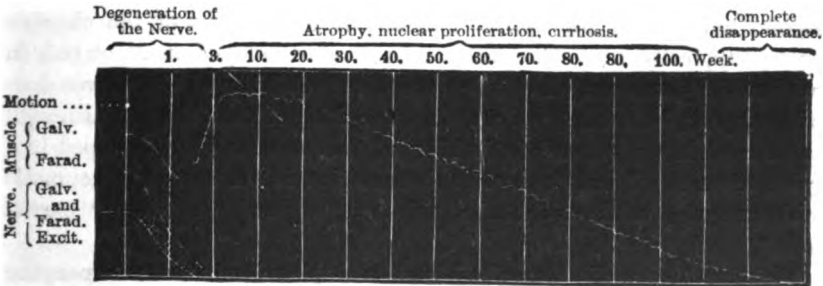

FIG. 28.—Schematic representation of complete De R with regard to motion, and the faradic and galvanic irritability of the nerve and muscle.

current on the one hand, and the great increase and qualitative change of galvanic irritability on the other hand. The further course of these degenerative changes, the increasing atrophy of the muscular fibres, cause the later depression of galvanic irritability. The compensation of these

changes and the return of the previous volume of the muscles give rise to the restoration of normal irritability.

With a view to the more ready comprehension of the facts I append three plates of De R and its relations to degenerative atrophy. In all three the first heavy ordinate indicates the occurrence of the lesion, the sudden cessation of mobility (°°°°), its beginning return is indicated by an asterisk (*); in the first plate you find an early, in the second a late, in the third no return of mobility. The figures above the ordinates indicate the number of weeks which have elapsed since the occurrence of the lesion. The wavy shape of the line, showing the galvanic irritability of the muscles, indicates its qualitative alteration. The short remarks above the plates point out approximately the stage of the histological changes in the nerve and muscle.

But it should not be expected that a similar regularity in the course of the changes will be observed in all pathological cases, as it is in an experiment or in simple traumatic lesions of the nerves. There are numerous deviations from complete "De R," which may be occasioned by the form of the lesion, various disturbances of the trophic influences, temporary improvement, constantly recurring fresh disturbances, etc. Even the period at which the regeneration of the nerve begins may produce great differences in the general symptomatology of the De R. If the regeneration occurs early, the nerve may be irritable to the faradic and galvanic currents, while the changes in the muscle are still at their height. It may therefore happen that the muscle reacts in a normal manner to the nerves, but direct irritation still produces De R. If the regeneration occurs very late the muscular changes may have passed into the later stages, with greatly diminished galvanic irritability when the electrical irritability of the nerves begins slowly to reappear.

But there is an entire series of cases in which the course does not correspond entirely to the above scheme, but only a part of the changes develops typically, while the remainder are not developed at all, or only in a rudimentary manner. In these cases the irritability of the nerves does not disappear, but sinks to a certain, often insignificant, degree, although the changes in the galvanic irritability of the muscles are developed in a typical manner. I first observed this condition in six cases of rheumatic facial paralysis, and have included this category under the term "partial De R."

This can be readily described, and is depicted on the accompanying plate.

Merely a slight depression of faradic and galvanic irritability occurs in the nerves; this is often very insignificant but always distinctly demonstrable. It is often manifested more by the diminution of the maximum contraction than by the later occurrence of the minimum contraction. A corresponding diminution of faradic irritability also appears in the mus-

de, while the galvanic irritability presents the same changes as in complete De R. But experience teaches that in all these cases of partial De R, the disease is comparatively mild and disappears with relative rapidity.

In these cases it is probable that the nerve is not degenerated, or very slightly, while the muscle presents the same histological lesions to which we previously attributed the changes in their electrical irritability.

Experience teaches that all possible gradations may occur between normal reaction and partial De R, and between the latter and complete De R, and you may not infrequently observe, in the same individual, that partial and complete De R are present in different parts of the muscles.

Occurrence.—You will have foreseen that it is undoubtedly present in all forms of disease which are analogous to the experimental division

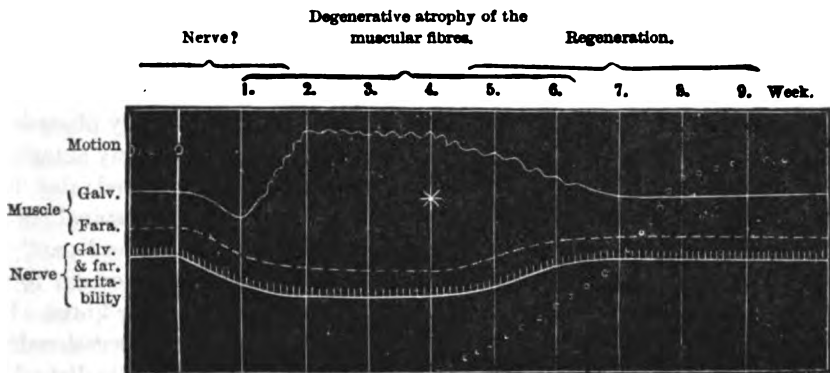

FIG. 34.—Schematic representation of partial De R. The faradic and galvanic irritability of the muscle are diminished to a slight extent. Motor power returns at an early period; complete and rapid recovery. Degeneration of the nerve probably absent.

or compression of motor nerves, viz: in so-called traumatic paralyzes, which are produced by injury, section, rupture, or bruising of the nerve. To this category also belong the numerous compression or pressure paralyzes, if the lesion of the nerve reaches a sufficient grade to destroy the trophic influences. You will learn hereafter that in mild forms of compression paralysis, motor conduction may be alone disturbed, while the completely intact electrical irritability allows us to conclude that all trophic disturbances of importance are absent. Among these compression paralyzes I not alone include those due to external mechanical pressure (sleeping on the arm, tight surgical bandages, tourniquets, difficult labor, poor crutches, etc.), but also to internal pathological processes (tumors, aneurisms, extravasations of blood, retraction of cicatrices, formation of callus, joint changes, etc.).

This also includes so-called neuritic paralyzes, especially those in which there is at first interstitial neuritis and mechanical pressure upon the motor fibres caused thereby, while in those forms which are described as paren-

chymatous neuritis, there is a primary degeneration of the nerve-fibres, which gives rise to an abolition of conduction in some part.

De R also occurs in many rheumatic paralyses, especially in certain forms of rheumatic facial paralysis. It is probable that, in these cases, slight neuritic changes are associated with compression of the nerves (especially during their course through narrow, bony canals).

De R is also found in spinal diseases, so far as these affect the gray anterior columns of the spinal cord ; therefore in the various forms of anterior poliomyelitis, in its acute as well as its subacute and chronic forms ; also in the disseminated chronic, progressive form (typical progressive muscular atrophy), and no less in chronic progressive bulbar paralysis, naturally also in so-called amyotrophic lateral sclerosis. In all these chronic forms, however, the De R usually appears in a part of the muscles alone and in great part as partial De R. The latter may also be observed in all the forms of disease previously mentioned (with the exception of severe traumatic paralyses).

You will not be astonished to hear that De R is occasionally observed in hemorrhages into the spinal cord (*hæmatomyelia*), if the gray anterior columns of the cervical or lumbar enlargements are implicated, also in various forms of acute and chronic myelitis, in tumors of the spinal cord under similar circumstances ; it is also a constant symptom in lead paralysis, with regard to which we are in doubt whether it owes its origin to a lesion of the anterior gray columns or of the peripheral motor fibres. It may also be mentioned that the De R in lead paralysis is occasionally observed in muscles which are not paralyzed, and in which trophic disturbances are, therefore, alone present.

De R is also found occasionally in diphtheritic paralyses which, in part at least, are attributed to neuritic and degenerative changes in the nerve-trunks and the motor-roots of the nerves. It may also be observed in paralysis after acute diseases (neuritis, hemorrhage, poliomyelitis, etc.), also in paralysis from syphilis, etc.

De R has *never* been observed in paralysis of cerebral origin (from lesion of the conducting paths above the gray nuclei of the medulla oblongata, or from lesion of the cerebral cortex) ; it never occurs in paralysis from disease of the white columns of the cord (with the exception of the anterior root-bundles), or in hysterical paralysis.

I also lay stress upon the fact that De R has never been found in undoubted local and primary affections of the muscles ; not in myositis and especially not in the so frequent atrophy and paresis of the muscles after joint diseases ; it is also entirely absent in all atrophies from disuse.

The following conclusion may be drawn with regard to the presence of De R, viz., that it presupposes the existence of considerable anatomical changes (degenerative atrophy) in the nerves and muscles (perhaps in the latter alone).

We may also conclude that the paralysis or atrophy which is present has a neurotic origin, and that some serious disorder must be situated either in the peripheral motor conductors, or in the trophic centres of the central organ, i.e., in certain portions of the anterior gray substance of the spinal cord or the medulla oblongata.

With regard to their nutritive conditions the motor nerves and muscles are under the influence of certain nervous apparatus (trophic centres), by whose continuous action they are retained in a normal histological and functional condition. We may entertain the suspicion that the large multipolar ganglion cells, or at least a part of them, possess these trophic functions.

Every separation of the peripheral nerves and muscles from this central apparatus disturbs their trophic actions, and the peripheral parts will undergo progressive degeneration until the connection with the centres is again restored. It is immaterial with regard to the effect whether the separation is due to interference with conduction or interruption of continuity in the peripheral paths, or to destruction or abolition of function of the centres: in both events degenerative atrophy is inevitable.

How these trophic influences produce their effect is merely a matter of conjecture. But all facts hitherto known agree in this, viz.: that true degenerative atrophy and De R occur in neurotic disorders alone and that these possess a definite situation; De R does not occur in undoubted primary affections of the muscles.

But there are cases of simple atrophy of the muscles, without degenerative changes and without De R, which may attain very high grades; they occur not infrequently in the last stages of severe spinal paraplegias, sometimes in consequence of severe cerebral paralysis; a somewhat similar condition is found in progressive unilateral atrophy of the face. From our previous experience we may assume that, in such cases, the gray anterior columns must be intact. This view has received corroboration from Strümpell's recently published case of spinal disease, in which extensive atrophy was present without any degenerative disturbance, without De R—but also without degeneration of the anterior gray columns. But we are still ignorant as to the real cause of this form of atrophy, whether it is due to simple inaction or to some other form or degree of trophic disturbance. Perhaps a portion of the muscular atrophies, which are so frequent in joint affections, belong to this group.

To return, after this digression, to the De R, its occurrence only teaches us, with reference to the diagnosis of any affection which may be present, that certain histological changes—degenerative atrophy—are present in the nerves and muscles, whence follows immediately a conclusion with regard to the severity of the lesion and the degree of disturbance of conduction.

With regard to the site of the lesion the De R merely shows with

certainty that we have to deal with a neurotic affection, and that the lesion must be situated either in the peripheral nerves, the motor roots, or the gray masses of origin. A true cerebral affection is positively excluded by the presence of De R.

With reference to the diagnosis of the kind of lesion, little can be determined, from the presence of De R, with regard to the more immediate cause of the paralysis.

Very important and practically valuable conclusions may be drawn in many cases with regard to prognosis.

Under otherwise similar circumstances, *i. e.*, in one and the same form and cause of disease, the lesion is so much more serious, the duration of the disease the longer, the chance of complete restitution slighter—the more developed and complete the De R is and the more advanced the stage in which it is found. Partial De R is therefore more favorable than the complete, the later stages more unfavorable than the earlier. A prognosis may thus be made in the individual forms of disease.

The most striking example of this is afforded by ordinary rheumatic facial paralysis, three forms of which are distinguished according to the duration and severity of the disease and are recognized by the results of the electrical examination. If the electrical irritability is entirely normal (mild form), the prognosis is very favorable and the disease will last two to three weeks; if partial De R is present (middle form), the disease will continue about one or two months; but if complete De R is present (severe form), the prognosis is relatively unfavorable and the paralysis will last from three to nine months or longer. Similar statements with regard to prognosis will also hold good of compression-paralysis of the radial nerve, and of one form of spinal disease, *viz.*, chronic anterior poliomyelitis.

It must not be forgotten, however, that these prognostic rules do not obtain for all possible paralyses but for those alone which possess a certain etiology and similar localization. It is therefore only true of rheumatic facial paralyses *inter se*, or of compression paralyses of the radial nerve *inter se*; but it is not permissible to compare a cerebral facial paralysis with one due to caries of the petrous portion of the temporal bone, or the latter with a rheumatic paralysis, or to compare the conditions of a compression paralysis of the radial nerve with one produced by the formation of callus, or with progressive muscular atrophy in this region.

The description of De R here given does not by any means pretend to be exhaustive in all directions and details; it furnishes merely the general typical picture, its regular appearance in simple and uncomplicated cases. But I will not fail to add a few explanatory and special remarks.

It lies in the nature of the case that all kinds of variation from the typical condition occur; pathology does not deal with simple and smooth experiments, but with varying, complicated, fluctuating, morbid processes. Their more rapid or slow development, the occurrence of improvement

and relapse, so that processes of degeneration and regeneration are mingled with one another, instead of developing in a regular series; circumscribed or manifold disseminated lesions, which affect only individual parts of the nerves and muscles in varying combination; repeated occurrence of degenerative atrophy in the same neuro-muscular tracts, as, for example, in recurring lead palsy; combination of various disturbances, which may lead at the same time to different kinds of change of electrical irritability—these are the chief factors which may disturb the regular course of the De R. As a matter of course, they produce an extraordinary variety and complication of conditions, which we must expect in pathological cases, and whose disentanglement and explanation can only be effected when we constantly keep in mind the possibilities just mentioned.

Above all, however, a very careful and skilful examination is necessary; by a large experience alone can the De R be recognized under less favorable circumstances and the characteristic peculiarities determined when they are very slightly marked. Especially in the later stages it is always very useful to introduce the greatest possible quantities of current into the muscles, in order to compensate somewhat for the advanced diminution of irritability: therefore large electrodes should be employed, the skin well moistened, the strength of the current increased by changes of polarity, perhaps both electrodes placed upon the muscle, and disturbing contractions of other muscles excluded as much as possible. The latter precaution is especially serviceable in examination of the small muscles of the hand, the ball of the thumb and the interossei, and is effected readily by applying the indifferent electrode either to the dorsal surface of the wrist-joint or the palm of the hand.

By means of these and similarly modified applications (made in accordance with Ohm's laws), it is usually possible to distinguish the relatively feeble and slow contractions of De R from the more vigorous contractions of the adjacent muscles. This can be rendered still easier by excluding the movements of the healthy muscles by means of suitable fixation. If the irritability is very much depressed during the latest stages and when the muscles are uninfluenced, it may happen that the excitability does not make its appearance distinctly until after repeated examinations. Very useful and important in many cases in the demonstration of beginning or slight degeneration, is the recognition of a form of "double contraction" which I have often observed and demonstrated: upon closure a short, lightning-like contraction of the adjacent healthy muscles is observed at the beginning and is followed immediately by the slow, characteristic contraction of De R. This may be noticed very distinctly in lead palsy, in which, upon stimulation of the extensors of the forearm, a short, lightning-like flexion of the hand and fingers occurs and is immediately followed by slow, less marked extension of these parts. It is very instructive, also, when, in beginning De R, Ca Cl produces a vigorous, lightning-like contraction, An Cl a slow, long-drawn contraction in one and the same muscle; this may be observed with special distinctness in bulky muscles (triceps or biceps brachii, vastus internus, etc.).

In certain cases of De R the stage of increased excitability appears to be very short, perhaps entirely absent, and the qualitative changes of excitability then develop alone. I lay much more stress upon these latter changes than upon the increase of excitability; the De R will always be recognized most certainly by the slow, insufficient contractions and the predominance of An Cl action.

Frequently no distinct changes can be demonstrated in old cases; there may be merely a simple diminution of excitability, including the galvanic excitability, and it may be doubtful whether De R has been present or not. In this event there may be numerous combinations with the simple diminution of electrical irritability due to spinal diseases.

It is a very interesting and theoretically important fact that well-developed De R is noticed occasionally in muscles which are not at all paralyzed or present merely a moderate and insignificant diminution of mobility. I noticed this first in a case of lead palsy; the deltoid presented no appreciable disturbance of motion, but marked typical changes of galvanic excitability with slight diminution of faradic excitability (the nerve-trunk was not examined). Kast has recently described a case under my observation in which the thenar muscles, although retaining normal power, presented complete De R, i.e., the nerve itself was inexcitable to faradic and galvanic currents.

A different reaction of the nerve to the faradic and galvanic currents, analogous to the De R in the muscles, has been observed in very exceptional instances.

It is a more noteworthy fact that, during a certain stage of De R, the degenerated muscle reacts with an exquisitely slow contraction to faradic stimulation and to stimulation through the nerve. In this event the muscular fibres are evidently so degenerated that they are no longer capable of contracting quickly as they usually do, for example, in cases of partial De R, when stimulated through the nerve. This peculiar reaction appears to occur only when the nerves are regenerated, or at least only in the later stages of the entire process, when it has run a very long course.

LECTURE X.

4. Rarer Quantitative and Qualitative Changes of Electrical Irritability: *a.* Increase of Secondary Irritability (Convulsive Reaction)—*b.* Diminution of Secondary Irritability (Exhaustion Reaction)—*c.* Qualitative Changes in the Law of Contraction of Motor Nerves—*d.* Different Reaction of the Nerves to the Faradic and Galvanic Currents—*e.* Latent Period of Irritation in Faradic Stimulation of the Muscles—*f.* Diplegic Contractions—B. Electro-diagnosis of the Sensory Nerves—Anomalies of Farado-cutaneous and Farado-muscular Sensibility.

4. RARE QUANTITATIVE AND QUALITATIVE CHANGES OF ELECTRICAL IRRITABILITY.

In this section I will give a short description of various rare forms of electrical reaction which have been observed occasionally but which are at the present time devoid of practical significance.

a. Benedict has described as *convulsive reaction* a quantitative change of irritability in which, after the current has been allowed to act for a short time, the contractions produced are much more vigorous than normal, and may even be intensified into convulsive contractions. This is probably the same as Brenner's "increase of secondary irritability." Under the term "secondary irritability" he refers to the degree of irritability, expressed in numbers, which is produced by the action of the current itself upon the nerves. If, for example, the nerve in the beginning shows the first Ca Cl C with sixteen elements, and after the current has passed for some time with twelve elements, "sixteen elements" indicates the primary, "twelve elements" the secondary irritability of the nerve. The farther these figures become removed from one another, the less, therefore, the number of elements which prove effective at a later period, the greater the secondary irritability, and *vice versa*. Unfortunately, the part played in this secondary irritability by changes in the resistance to conduction of the current itself has not been accurately determined, and to the latter must probably be attributed the lion's share of this phenomenon. But there is no doubt that cases occasionally occur which indicate a real change of irritability in this sense, as in certain psychoses, tumors of the brain, certain spasmodic diseases, chorea, tetany, etc.; but its occurrence has no appreciable practical significance.

b. The antithesis of the previous anomaly is the *diminution of secondary irritability, the reaction of exhaustion*. While healthy nerves and

muscles show no appreciable exhaustion and may be repeatedly stimulated effectively by the same irritant, it may happen under pathological conditions that the primarily effective strength of current afterward becomes inefficient. For example, the minimum contraction at first occurred at 180 mm. withdrawal of the cylinder; after some time, not until 160 mm.; and finally at 140 mm. Or the first Ca Cl C occurs with sixteen elements, but, after repeated closure of the current, eighteen or twenty elements are required to produce contraction.

This phenomenon has been observed in paralysis from disease of the cerebral hemispheres, in progressive muscular atrophy and in apoplectic hemiplegia; it has also been found in a case of true muscular hypertrophy, and in another case of probable chronic anterior poliomyelitis, temporarily during the gradual depression of faradic irritability of the muscles in the transition to De R.

c. Qualitative change in the law of contraction of the nerves. Qualitative changes in the law of contraction are as rare in the nerves as they are common in the muscles. Brenner, despite his extensive experience, has never observed any of these changes.

In two cases I observed, in the ulnar nerve, the occurrence of An Cl C before Ca Cl C, the contraction being of a purely nervous character (short, lightning-like). Both cases were chronic affections of the spinal cord, one being locomotor ataxia, the other a complicated disease (spastic paralysis of the legs, paresis with exaggerated reflexes in the arms, sensory disturbances, indication of ataxia in left arm alone, etc.). In this case An Cl C occurred earlier and more vigorously in the left ulnar nerve with feeble currents, while the normal condition was presented when stronger currents were employed. More careful examination showed:

With 10 elements	An Cl C'	Ca Cl
" 12 "	An Cl C >	Ca Cl C
" 14 "	An Cl C' >	Ca' Cl C
" 16 "	An Cl C' =	Ca' Cl C,
" 18 "	Ca Cl C'' >	An Cl C', An OC
" 20 "	Ca Cl C''' >	An Cl C', An OC, Ca OC

Petřina has repeatedly observed a similar predominance of the An Cl C in cerebral tumors.

Rumpf has found that the An OC occurs earliest and most readily if the nerves in question are separated from the central organ. He has also observed this in the human subject:

1. Crutch paralysis of the radial nerve, 15th day:

	Healthy side.	Diseased side.
Ca Cl C with 11° deflection of needle;		12° deflection of needle.
An Cl C " 29° " "		30° " "
An O C " 35° " "		25° " "

This shows increased irritability of An O.

2. Compression paralysis of the radial nerve, 8th day :

Healthy side.		Diseased side.
Ca Cl C with	21° N D.	33° N D
Ca D C >	38° "	37° "
An Cl C	36° "	35° "
An OC	32° "	23° "

In this case, accordingly, diminution of irritability to Ca Cl and increase to An O.

d. Different reaction of the nerves to the faradic and galvanic currents. Soon after the discovery of the De R the difference in the reaction of the muscle to the faradic and galvanic currents was also supposed by the majority of observers to hold good with regard to the motor nerves. I showed that this opinion is incorrect and that in De R the nerve reacted in exactly the same manner to the faradic and galvanic currents. It appeared indeed as if this were always the case, at least no other result was obtained in the innumerable observations of De R in the human subject.

But there are a few facts which prove that this change of irritability in the nerves really occurs. Bernhardt has recently described a case of traumatic ulnar paralysis in which this nerve presented distinct diminution of faradic irritability, and a not inconsiderable increase of galvanic excitability. But this case belongs undoubtedly to De R, despite the incomprehensible repeated assurance of the author "that no De R was present;" according to the clinical history, the muscles supplied by the ulnar nerve presented increased galvanic excitability, predominance of An Cl C, and a slow mode of contraction, with markedly diminished or entirely extinguished faradic irritability.

e. Latent period of irritation in faradic stimulation of the muscles. By means of an apparatus devised by Marey, M. Mendelssohn has measured the period of latent irritation of the muscles in the human subject; he employed only the faradic current as the irritant, and found that this period presented a variable duration (0.006 to 0.008 second on the average), dependent on the intensity of the current on the one hand, and on the irritability and contractility of the muscles on the other hand.

Under pathological conditions, numerous variations occurred in the duration of this period of latency; it stands in an inverse relation to the irritability and contractility of the muscles. Its duration diminishes constantly in contracted muscles, and increases with the existence and intensity of trophic changes in the muscles. Thus, Mendelssohn found a diminution of the period of latency (to 0.003 second) in hemiplegias with contracture of the muscles, in spastic spinal paralysis, chorea, etc.; and a prolongation of this period (to 0.02 to 0.04 second) in hemiplegia complicated with atrophy, in progressive muscular atrophy, in amyotrophic lateral sclerosis, in ataxia during the stage of paralysis and atrophy, and also in hysteria (0.009 to 0.015 second).

It would be interesting to investigate somewhat more closely the relations of the period of latency in degeneration reaction.

f. Diplegic contractions. Under this term R. Remak first called attention to remarkable phenomena of contraction which occur in rare cases if the electrodes of the galvanic current are arranged in a certain manner. If the button-shaped anode is placed in one mastoid fossa, or upon the adjacent part of the neck, and a broad plate-shaped cathode is put between the scapulæ or even somewhat lower on the other side of the vertebral column, peculiar, more or less vigorous movements will occur in the arm on the side opposite the anode, even if the electrodes are kept immovable. The contractions are said to remain absent if the position of the electrodes is reversed, also if the Ca is brought into the region of the neck.

Remak looked upon these contractions as reflex and regarded the superior cervical ganglion as their chief point of departure, later the simultaneous irritation of two sympathetic ganglia. The electrodes must therefore be situated far apart. The occurrence of diplegic contractions may be facilitated and strengthened by the administration of strychnine. Remak observed them especially in progressive muscular atrophy and arthritis nodosa and attributes great curative properties in these diseases to galvanic treatment by means of this diplegic arrangement of the electrodes.

These phenomena have been rarely observed by later writers. Drissen found diplegic contractions in a vasomotor neurosis and in paresis of the nerves of the arm; Moritz Meyer in arsenical paralysis, Fieber in lead paralysis, apoplectic paralysis, etc., Eulenburg in lead paralysis; Eisenlohr found them slightly developed in bulbar paralysis (but with reversed position of the poles). I have observed feeble diplegic contractions in a case of progressive muscular atrophy; in a case of atrophic paralysis of the arms, with sensory and trophic disturbances of the skin (neuritis? spinal disease?), they did not occur distinctly until the patient had taken strychnine for some time; in a third case of atrophy of the muscles of the hand and forearm (the interpretation of which was difficult) rhythmical contractions occurred in various muscles of the fingers and forearm upon diplegic stimulation with both directions of the current; the muscles remained motionless on direct irritation of the brachial plexus.

The statements of various observers with regard to the best manner of producing these contractions only agree to a slight extent with those of Remak. Fieber could produce the contractions with the faradic current. Moritz Meyer produced them from other points (pit of stomach, dorsal spine), while Eulenburg found that they appeared "upon crossed and even unilateral application to any part of the surface of the trunk with a stabile or labile current." You thus see how different the statements are with regard to these diplegic contractions. They possess no special importance from a diagnostic or therapeutic standpoint. To this category

of reflex phenomena belong also the "galvano-tonic reflex contractions" which were so carefully studied by Remak, and also the contractions obtained, upon galvanic stimulation of a leg, in the arms or the non-irritated leg (in hemiplegia, ataxia, etc.), and which are said to be caused by centripetal action of the current. It is probable that these phenomena are due merely to an unusual degree of reflex irritability; they possess no practical significance.

B. THE CHANGES IN THE ELECTRICAL IRRITABILITY OF THE SENSORY NERVES.

From a pathological standpoint very little is known with regard to the electrical reactions of the sensory nerves. We are acquainted only with simple increase (hyperæsthesia) or diminution (anæsthesia) of electro-cutaneous sensibility, which usually runs parallel, to a greater or less extent, with the disturbances of the remaining qualities of tegumentary sensation (especially the sensation of pain). These disturbances may occur in the most different morbid conditions and are determined by the methods previously described (Lecture VII, p. 66). Electricity serves merely as a test of function and does not determine the changes in the irritability of the conducting paths, as it does in the case of the motor nerves.

Thus we can ascertain that the electro-cutaneous sensibility is increased or diminished in various peripheral as well as central (especially spinal) diseases, and in what parts this occurs. Especially in unilateral affections we can often determine very slight changes by faradic examination better than by other methods of testing sensation. As an illustration I append a case of traumatic lesion of the vertebral column, followed by slight weakness and anæsthesia of the left leg, the latter symptom being readily detected by the electrical examination.

A man, aged twenty-four years:

Point of irritation.	Minimum.		Pain.		Deflection of needle with 12 elements, 150 C R
	Right side.	Left side.	Right side.	Left side.	
Cheek	230	205	155	164	12°-16°
Neck	200	195	152	152	3°- 4°
Forearm	180	165	150	135	3°- 3°
Tip of fingers.....	144	140	110	112	5°- 4°
Thigh	180	142	138	119	3°- 2½°
Calf	195	142	145	100	2°- 2½°
Sole of foot.....	105	77	75	52	4°- 5°

In locomotor ataxia it has been ascertained that the electro-cutaneous sensibility runs parallel, on the whole, with the sensibility to pain, and that if analgesia is present, tactile sensation being unimpaired, the minimum of faradic sensibility as well as of the faradic sensibility to pain first develop with much higher strengths of current. In many cases the farado-cutaneous sensibility appears simply diminished over the entire body and the difference in the withdrawal of the cylinder for the minimum sensation and pain is not much greater in many ataxics than in healthy persons. But the faradic examination discloses anomalies which may readily escape observation by the ordinary examination of sensation. The following case will serve as an illustration.

Locomotor ataxia, man aged thirty-six years (the numbers for both sides of the body are grouped together, as they were approximately equal) :

Points of Irritation.	Minimum in mm.	Pain in mm.	Deflection of needle. 10 elements.
Cheek	150	120	26°
Neck	154	110	20°
Arm	154	110	12°
Forearm	152	108	7°
Dorsum of hand	144	103	10°
Tips of fingers	90	70	3°
Abdomen	136	100	16°
Thigh	128	85	5°
Calf	120	78	5°
Dorsum of foot	112	70	4°
Sole of foot	85	45	10°

A comparison with the normal tables distinctly shows the general diminution of farado-cutaneous sensibility.

In but one case of ataxia did I find an evident farado-cutaneous analgesia, while the numbers of the minimum sensation were scarcely diminished. In this case the numbers of the minimum farado-cutaneous sensation varied from 203 mm. (cheek), 170 (arm), 177 (thigh), 150 (sole of foot), but absolutely no sensation of pain could be produced in any part of the body by the most powerful current. This condition appears to be exceptional, however, even in locomotor ataxia.

LECTURE XI.

C. Electro-diagnosis of the Nerves of Special Sense. 1. Optic Nerve and Retina—2. Acoustic Nerve and Auditory Apparatus—*a.* Simple Galvanic Hyperæsthesia—*b.* Hyperæsthesia with Change and Reversal of Normal Formula—*c.* Qualitative Anomalies without Hyperæsthesia—*d.* Torpor—3. Nerves of Taste—Electrodiagnosis of the Vasomotor Nerves, the Sympathetic, Pneumogastric, Central Nervous System, etc.

C. CHANGES IN THE ELECTRICAL IRRITABILITY OF THE NERVES OF SPECIAL SENSE.

1. To my regret I must admit that very little is known with regard to the pathological relations of the electrical irritability of the retina and optic nerve.

It has long been known that the galvanic reaction of the visual apparatus diminishes and disappears in amaurosis, atrophy of the optic nerve, and similar lesions, but Neftel first made detailed statements based upon Brenner's method of examination: in a case of hemianopsia he found a corresponding defect in the galvanic color disk, and this is also said to occur in separation of the retina; he finds that, as a rule, the galvanic reaction of the eyes is parallel with the acuteness of sight.

I have made a few investigations in this direction but I must confess that they are incomplete in many respects.

I make brief mention of the following personal cases:

1. Double optic neuritis with secondary atrophy of optic nerves; amblyopia (fingers visible at 6 and 2 feet). Feeble galvanic sensation of light on both sides: whitish, without any difference between both poles or at opening and closing the current.

2. Fracture of skull. Left eye completely amaurotic; right eye, amblyopia and temporal hemianopsia. No galvanic reaction in left eye; in the right eye galvanic sensation of light, confined almost exclusively to median (left) half of the field of vision.

3. Case of locomotor ataxia with complete amaurosis from atrophy of the optic nerves; formerly had distinct galvanic sensation of light; this is now entirely absent, however strong the current employed.

4. *Tumor cerebri* (?). Bilateral complete amaurosis; at first choked disk, later white atrophy of the optic nerves: indifferent electrode placed upon the neck; when the active electrode is placed upon the right temple, upon the right or left closed lid, a sensation of light is produced upon the

right side alone, upon Ca Cl and An Cl ; if the active electrode, however, is placed upon the left forehead, then a feeble sensation of light is perceived upon the *left* side in addition to that on the right.

5. *Amblyopia of right eye* from retrobulbar neuritis. Vigorous galvanic reaction in the left eye ; no sensation of light in the right eye with 6 and 8 elements ; a few months later, after distinct improvement of vision had occurred, the right eye also reacted distinctly, but more feebly than the left.

6. *Bilateral amaurosis* as the result of a pistol-shot wound of the left temple ; feeble vision on left side, absolute blindness on the right side ; smell lost. Distinct sensation of light on right side, with 4 to 6 elements and the most direct galvanic stimulation possible. On the left side, feeble sensation with 2 elements, strong sensation with 4 elements (considerable improvement of vision at a later period).

I refrain from drawing any conclusions from my observations, but I believe that the study of this field would be well repaid and I recommend it to the attention of ophthalmologists.

2. We are much more fortunate with regard to the electro-pathological reactions of the nervous auditory apparatus. It has been found, in a certain series of cases, that the results of the electrical examination not alone furnish indications for electrical treatment, but also for the special method to be adopted. In most cases we have to deal with obstinate tinnitus aurium, which can be relieved by no other method but is often cured by the galvanic current.

Brenner in his investigations found a number of anomalies in the galvanic reaction of the acoustic nerve, all of which have been corroborated by later observers. The most frequent of these is

a. *Simple galvanic hyperæsthesia of the acoustic nerves.* It is characterized by more ready irritability of the nerve without any change in the normal formula. The readiness with which the nerve reacts in such cases is often astonishing ; the complete formula of acoustic reaction may be obtained with a scarcely perceptible current.

Increased reaction to very feeble currents is therefore the first and most striking criterion of this galvanic hyperæsthesia ; it is manifested not alone by the fact that Ca Cl produces sensations very early, but also that An O sensations occur with relatively feeble strengths of currents, near to Ca Cl sensation.

The sensations of sound are also unusually loud and of very marked timbre and character (loud whistling, hissing, ringing of bells, etc.).

Furthermore, these sensations continue much longer than normal, so that very soon the Ca Cl ringing continues during the entire duration of the closure of the current, although with somewhat diminished intensity, and the otherwise momentary An O reaction is converted into a more or less prolonged (sometimes 20 to 40 seconds) loud ringing, which gradually subsides.

Brenner has further shown with regard to this hyperæsthesia, that the secondary and tertiary irritability is considerably increased, and that the increased irritability is manifested with simple positive and negative changes of polarity, as well as in various other respects.

Brenner's "paradox reaction" must be regarded as an especially high grade of hyperæsthesia. This is characterized by the fact that when one ear alone is armed and examined—the other electrode being placed in the hand or on the sternum—the unarmed ear also reacts, in the same manner as if it were armed with the indifferent electrode. This condition appears

paradox because Brenner has shown that the acoustic nerve always reacts to the electrode situated nearest to it. But it can be readily shown that, in the method of application referred to, the threads of current entering the skull at the one ear must leave it in the neck, whether the indifferent electrode is situated in the neck, sternum, leg or hand; this condition is the same, however, as if the indifferent electrode occupied the entire neck. But the unarmed ear is in closer proximity to the neck than to the armed ear, and consequently it must react to the indifferent electrode situated in the former locality. Thus this phenomenon loses its paradoxical character. It is nothing more than the expression of so marked

an increase in the galvanic irritability of the acoustic nerve that even the feeble currents which reach the unarmed ear are capable of evoking sensations of sound in the latter. It would be better perhaps to discontinue the use of the term "paradox reaction."

Simple galvanic hyperæsthesia of the acoustic nerve is a very common phenomenon; I have very often found it accidentally in individuals who were scarcely aware that their auditory apparatus was not normal. It occurs with very moderate disturbance of hearing, with but slightly distinguishable changes in the ear (opacity and retraction of the membrana tympani, partial atrophy of the latter, etc.); very frequently in all possible chronic diseases of the ear, old purulent otorrhœa, purulent inflammations of the middle ear, destruction of the membrane, chronic catarrh of the middle ear with difficulty of hearing and tinnitus aurium; also in caries of the petrous portions of the temporal bone, in gunshot and other injuries of this bone from fractures of the skull, in rheumatic and traumatic facial paralysis, etc.

Brenner has also pointed out a strikingly frequent coincidence of this (and other) pathological reactions of the auditory nerve with central or intracranial disturbances in the organ of sight; as in paralysis of the ocular muscles, mydriasis, paresis of accommodation, etc., following frac-

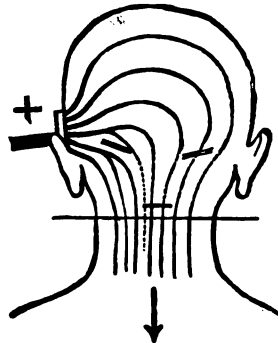

FIG. 25.—Schematic representation of the distribution of the current in the skull when one ear is armed with the An; the position of the virtual cathodes is shown upon the neck.

tures of the skull or intracranial diseases of various kinds. This is frequently merely an accidental coincidence, but in many cases there is a direct connection, the central disease giving rise to both disturbances.

In fact, galvanic hyperæsthesia (and other anomalies) of the acoustic nerve are occasionally observed in central diseases (locomotor ataxia, chronic myelitis and encephalitis, cerebro-spinal meningitis, tumors, etc.). Their intimate connection with the central disease has not yet been ascertained. Very interesting also is the repeated demonstration by Jolly of galvanic hyperæsthesia of the acoustic nerve (with or without qualitative anomalies of the formula) in auditory hallucinations.

Brenner has formulated a very attractive explanation for the development of galvanic hyperæsthesia in ear diseases. He starts with the well-known fact that our nerves of special sense fall into a condition of increased irritability if their adequate stimuli are withdrawn for a protracted period; if kept for a long time in the dark, we therefore learn to distinguish our surroundings, are dazzled by ordinary daylight, and recognize electrical images more distinctly in the dark than in the light. This is also true of the auditory nerves; but if this condition of deprivation of auditory stimuli lasts for a long time, nutritive disturbances occur in the nerves, which are manifested by increased and perverse reaction of the auditory nerve, and may finally lead to diminution of irritability.

This explanation will hold good for those cases alone in which the galvanic hyperæsthesia is combined with disturbances of hearing, with diseases of the auditory conducting apparatus; and these cases undoubtedly form the majority. But there are cases of galvanic hyperæsthesia (even with a change of the normal formula) in which no trace of auditory disturbance can be demonstrated, and some other mode of development must be acknowledged for such instances.

The coincidence of simple hyperæsthesia with nervous tinnitus aurium is extremely frequent and practically of the greatest importance. I will refer to this subject in the section on therapeutics. It may here be mentioned that a part of these subjective noises appear to develop in the nerve itself. In many of these cases simple hyperæsthesia of the auditory nerve is present, and they are characterized especially by the fact that the electrical current has a sedative influence upon the tinnitus aurium. As a rule, the subjective noise ceases forthwith and completely at An C1 and An D, but occurs with its former or increased intensity at An O, while Ca C1 and Ca D cause a considerable increase of the roaring, and Ca O a temporary diminution.

In another series of cases of subjective noises, the cause must be sought outside of the nerve; these are entirely uninfluenced by the galvanic current, whatever its direction and strength.

There is also a third group, in which two kinds of noises are present at the same time, one of which is diminished by the current, the other en-

tirely uninfluenced thereby. Hyperæsthesia is usually present in these cases, though not always in a pure form ; the former of these noises must probably be located in the nerve.

We therefore possess in the galvanic examination of the auditory apparatus—on the one hand in the demonstration of galvanic hyperæsthesia of the auditory nerve, on the other in the determination of the sedative or stimulant action of the various factors of galvanic irritation upon the nervous tinnitus aurium—a very important diagnostic aid in recognizing certain forms of this annoying affection as probably of a nervous character and in differentiating them from other forms. You will learn at a later period what important prognostic and therapeutic data are also furnished by this examination.

We must regard as a further, though somewhat more rare, development of simple hyperæsthesia :

b. Galvanic hyperæsthesia with anomaly and even reversal of the normal formula. In addition to the normal sensations of sound, other pathological ones occur, at first An Cl and An D sensations, later Ca O sensation, all with the signs of hyperæsthesia. In almost all cases the newly developed sensations are very clearly distinguished by their character and timbre from the normal sounds. Among themselves the pathological sounds correspond as completely as the normal sensations in healthy individuals or the Ca Cl and An O sensations in simple hyperæsthesia.

The following case will serve as an illustration :

A man aged fifty-four years. Chronic difficulty of hearing ; tinnitus aurium. Opacity and depression of tympanum.

Left ear. External method of application, indifferent electrode on the hand. 10 elements.

Ca Cl, shrill, loud whistling.

Ca D, continuous whistling.

Ca O, short humming noise.

An Cl, loud humming and roaring

An D, gradually diminishing humming.

An O, whistling as in Ca Cl.

In addition, these new pathological sensations may gradually increase in intensity ; they appear earlier and more readily than the sensations produced by the normal factors of irritation, and these, on the other hand, grow weaker and weaker. Finally, the normal sensations may entirely disappear and the pathological ones alone remain, although the irritability is still increased ; the hyperæsthesia is then attended with complete reversal of the normal formula.

The following personal case will serve as an illustration :

A lady aged sixty years ; on the right side simple hyperæsthesia, on the

left side hyperæsthesia with reversal of the formula. Difficulty of hearing on the right side, complete deafness on the left. Marked tinnitus aurium, especially on the left side. Old ear disease, formerly considerable discharge; marked opacity and retraction of both membranæ tympani.

External method of application, the indifferent electrode placed in the hand.

Right ear, 4 elements.	Left ear, 6 elements.
Ca Cl, loud whistling noise.
Ca D, continued whistling.
Ca O,	slight whistling.
An Cl,	loud whistling.
An D,	continued whistling.
An O, slight whistling.

That is, a reversal of the normal formula on the left side, with somewhat less hyperæsthesia than on the right. Ca Cl causes cessation of the tinnitus in the left ear, but this continues unchanged at An Cl.

These forms of hyperæsthesia with change and reversal of the normal formula occur, as it seems only in very severe and old diseases of the ear, in serious affections of the middle ear, diseases of the labyrinth, and the like. In these cases, finally, the hyperæsthesia may diminish and disappear, and then the anomalies of the formula alone remain. We then speak of

c. Qualitative anomalies of the galvanic acoustic reaction without hyperæsthesia. Under this head are included all those anomalies which are not attended with special readiness of irritability of the acoustic nerve. All possible gradations may occur between the development of reaction to all six factors of irritation and simple reversal of the formula, addition of one or the other pathological reaction, absence of one or the other normal reaction, etc., so that the most varied formulæ may be presented.

It is by no means certain that all these anomalies develop from a previous simple hyperæsthesia; it is not even probable, since an entire series of observations (for example, in rheumatic facial paralysis, central affections, injuries to the skull, etc.) teach us that injuries and nutritive disturbances may occasionally act directly upon the auditory nerves in such a way that they react at once in an abnormal manner. Finally, mention should be made of the possibility that qualitative changes in the formula are perhaps induced by changes in the anatomical relations of the external parts surrounding the auditory nerves, so that threads of current, *i. e.*, the virtual pole, may reach the auditory nerve in another manner than in the normal auditory apparatus.

These changes occur usually in old, more or less severe diseases of the ear; they have also been observed with striking frequency in rheumatic facial paralysis, and occasionally in central affections.

As a matter of course a different form of galvanic reaction may be found in each ear, according as the aural affection is unilateral or varies on the two sides in kind, intensity, and duration. The skilled physician will have no difficulty in unravelling such a condition by careful examination, and the greatest possible isolation of each ear during the examination by the use of a branched electrode.

I must finally add that we are warranted in accepting the idea of a condition of

d. Torpor of the auditory nerve. This means a diminished galvanic irritability of the nerve. The nerve can be stimulated by very considerable currents alone, then gives merely feeble Ca Cl sensations, often none at all.

You are aware that even under normal conditions galvanic stimulation of the auditory nerves is frequently unsuccessful: we must therefore be very cautious in adopting the notion of torpor of the acoustic nerve. This diagnosis can be made most readily in cases of unilateral disease or when we can directly follow the gradual transition from abnormal readiness of irritability to pathological difficulty in evoking irritability, as occurred in one of my cases.

Torpor of the auditory nerve generally occurs only in severe and incurable disturbances of audition, although no definite relation can be determined to any anatomical changes which may be present. This anomaly is rare and recognizable with difficulty.

3. With regard to galvanic stimulation of the *nerves of taste* nothing has hitherto been determined, under pathological conditions, beyond simple diminution or loss of the galvanic sensation of taste, which is readily recognized by the methods previously mentioned (page 65).

Concerning the electro-diagnosis of the *olfactory nerves*, and also of the *vasomotor* and *secretory nerves*, the *cervical sympathetic*, the *pneumogastric*, the *heart-muscle*, *bladder*, *uterus*, *central organs of the nervous system*, etc., we know nothing at the present time; the observations hitherto made cannot be utilized practically. As a beginning worthy of notice we may mention the observations made by Hitzig on the reaction of paralyzed muscular fibres of the vessels. He found in several cases of paralysis of the axillary nerve that, in the region of circumscribed anæsthesia of the skin caused thereby, the integument became entirely white upon stimulation with strong labile galvanic currents, while the surrounding healthy portion acquired a purple color. Stimulation of longer duration, the application of a strong stabile galvanic current or of a faradic brush kept in one place, produced, on the other hand, more or less marked dilatation of vessels with the formation of wheals. Hitzig observed similar though less marked phenomena in other paralytic and trophic disorders, but the subject has not been investigated further.

70 vml
ABBOUUAO

PART IV.

GENERAL ELECTRO-THERAPEUTICS.

LECTURE XII.

The Therapeutic Value of Electricity—Various Electro-therapeutic Theories—Empirical Standpoint—Utilizable effects of the Current and the Method Employed—Stimulating, Modifying (Refreshing), Catalytic Effects—Empirical Basis of the Latter—Direct and Indirect Catalysis—Therapeutic Galvanization of the Cervical Sympathetic—Reflex Effects of the Current.

WE now turn to a consideration of the therapeutic value of electricity, to the estimation of its curative properties in the most varied forms of disease and thus to a determination of its practical therapeutic effects.

We may state, unhesitatingly, that electricity is an extremely powerful and many sided remedy, and that more evident and undoubted curative effects may be attributed to it in diseases of the nervous system than to almost any other remedy. The experience of the last thirty years leaves not the least doubt that electricity is valuable in the treatment of neuralgia, anæsthesia, spasms, and paralysis, in diseases of the peripheral nerves as in those of the central nervous system, and that its introduction into therapeutics has caused a more favorable prognosis in many forms of disease. I am not guilty of exaggeration when I say that the curative effects not infrequently astonish even the experienced physician by their magical rapidity and completeness.

Despite these facts, however, we know extremely little of a positive nature with regard to the finer processes in electrical curative effects, or their connection with the, to a certain extent, well-known physiological effects of electrical currents.

The chief difficulties in this problem appear to me to lie on the pathological side of the question, viz., in our ignorance of the finer nutritive or molecular changes occurring in the nerves in various diseases. We possess scarcely any positive knowledge concerning the real nature and final causes of the so frequent inflammatory disturbances, degeneration,

atrophy, etc., of the tissues! And how much less do we know concerning the more subtle processes in the various disorders of the nervous system, in neuralgias, spasms, paralyses and other manifold neuroses!

On the other hand, our knowledge of the various effects of electricity is by no means so extensive as many seem to think. We are accurately acquainted only with the irritating and modifying action of electrical currents upon the nerves and muscles; concerning so called electrolytic effects upon the living animal we know practically nothing, and this is also true of so called cataphoric action; with regard to our "catalytic" effects, which are now referred to so frequently, it may be said that they are almost entirely hypothetical.

And who will affirm that there are not other at present unknown effects of electricity upon the living organism, upon which the most important therapeutic results depend?

These remarks will suffice to give you an approximate idea of the real value of previous electro-therapeutic theories, and I will therefore make but a few statements concerning the most important ones.

The greatest authority was enjoyed by the electrotonic theory, according to which the majority of the curative effects of electricity are due to its modifying action (increase or diminution of irritability). What appeared more natural than that neuralgia and spasms could be relieved by the sedative action of the anode, with production of anelectrotonus, anaesthesia and paralysis cured by the exciting action of the cathode, with production of catelectrotonus? But apart from the fact that we are not certain that an increase of irritability really occurs in the one group of cases, and a diminution in the other, it must be remembered that electrotonic action disappears very rapidly after the cessation of the current, while the curative effects of the current are more or less permanent. It may also be objected to the electrotonic theory that a purely polar action can scarcely be produced in a single nerve of the body (perhaps with the exception of the acoustic nerve). Under all circumstances it will be impossible to explain the manifold curative properties by electrotonic action alone, although a certain space in therapeutics must be reserved for such action.

According to the stimulation theory, electricity acts merely as an irritant, and cure is effected by the various gradations of this irritant. But this theory does not advance us a single step further. At all events, it is no sufficient argument for this hypothesis that the electrotonic theory is unacceptable, and that apart from the electrotonic effects of electricity we are only positively cognizant of its action as a nerve stimulant. And how shall the stimulant action of the electrical current explain its manifold curative effects in the most varied affections, in those of a diametrically opposite character. We will see, at a later period, that a part, but by no means all, of the curative results can be explained in this manner. It is possible, however, that the electrical irritation of the trophic tracts and

centres may modify the nutritive processes in the nerves, muscles, and other tissues, may further regeneration, remove finer nutritive disturbances, and thus cause recovery of morbid processes. It does not appear to me inconceivable that, for example, the undoubtedly favorable effect of methodical exercise upon the nutrition of the muscles is attributable to the fact that every motor irritation is associated with irritation of trophic fibres, and that the nutritive processes are thus stimulated. May not many curative effects of electricity be explained in a similar manner?

This view encroaches upon the domain of the theory of catalytic effects. The latter hypothesis attributes all electro-therapeutic results to a sum of effects among which the trophic effects mentioned are not absent, but which also include the action upon the blood-vessels and vasomotor nerves, upon electrolytic and osmotic processes, and the mechanical effects of the current. I have previously stated (Lecture VI, page 56), that these "catalytic" effects are still hypothetical to a great extent; it follows, therefore, that such effects can not be made the basis of an electro-therapeutic theory, but at the most the starting-point for further investigations.

We are thus compelled to acknowledge the deficiency of the theoretical basis of our electro-therapeutical knowledge; now, as formerly, it must be studied upon an empirical basis. Only from a large number of further observations will we be enabled to gain, by degrees, a correct theoretical conception of electrical curative action.

After these general remarks I will advert to those effects of the current which can possibly prove of value in therapeutics. I will briefly mention the purposes for which they can be utilized, and by what methods they can best be produced.

The most frequently employed action of the current, and the one which admits of the most varied application, is the stimulating, irritating effect. It is indicated under various circumstances, especially in peripheral but frequently also in central diseases; in those cases in which we may expect to relieve pathological conditions by strong irritants; when we desire to overcome resistances to conduction in the sensory or motor nerve-tracts by a vigorous condition of stimulation, or to renew the depressed irritability by frequent action of a stimulus; furthermore, when we wish to stimulate the nutrition of the parts by action upon the trophic nerves, to effect circulatory changes by acting upon the vasomotor nerves, or to further the restitution of atrophic muscles by securing muscular contractions; or finally, when we wish to act, from the sensory parts, in a reflex manner upon the central organs, and through these upon the various peripheral organs, upon vasomotor paths, motor nerves and muscles, respiration and circulation, etc.

The methods by which these objects are effected follow readily from the remarks previously made; the faradic current is introduced by means

of moist electrodes of a suitable shape and size when the deeper parts are to be stimulated ; by means of dry electrodes (best with a metallic brush) when the nerves or other tissues of the skin are to be vigorously irritated ; the latter method is especially advisable to secure reflex effects.

More numerous methods may be employed for producing irritation by the galvanic current ; most readily by cathodal closures, which may be repeated with increasing strength and frequency ; anodal closure and opening are much less effective. An admirable method of obtaining irritating effects is by R. Remak's labile action of the current, especially the labile action of the cathode. This is done in the following manner : the well-moistened Ca is moved up and down quite rapidly over the nerve-trunk or muscle to be irritated, with a strength of current sufficient to produce vigorous, wave-shaped contractions (a current which will produce Ca Cl C in the same nerve is usually sufficiently strong). The vigorous stimulant effect of this irritation is due exclusively to the fact that, during the stroking movement, new parts of the nerve or muscle are successively brought into the domain of the electrode and thus of the greatest density of the current, and are thereby stimulated. A labile effect can also be produced with the anode, though not so powerfully as with the Ca. Remak has applied the term "terminal labile stimulation" to stroking with the Ca over those parts of the long muscles situated nearest to the tendinous ends, the current being allowed to pass, as far as possible, throughout the entire length of the muscle.

The most vigorous method of irritation is rapid change of polarity, especially to Ca after the An has been allowed to act for some time. Frequent repetition of these changes of polarity is often the only manner in which contractions can still be produced in markedly atrophic muscles with very much diminished irritability.

The site at which these applications must be made naturally depends upon the location and character of the disease, and also upon the object to be attained. I will merely remark that, in order to overcome obstacles to conduction in the nerve-paths, the stimulation of the sensory nerves should be performed peripherally from the site of the lesion, that of the motor nerves as central as possible ; the stimulation of degenerated and atrophic nerves and muscles must be effected upon these organs themselves.

The modifying, irritability-changing effects of the current are also very often required. In fact there are a number of cases in which we may expect a favorable result from such action ; whenever we assume a diminution in the irritability of the nerves and muscles, in certain paralyses and anæsthesia, in certain vasomotor affections, even in certain conditions of depressed spinal and cerebral activity, we are justified in resorting to the catelectrotonic action of the current (stimulating, strengthening, anti-paralytic, refreshing action), while the anelectrotonic action of the current

should be resorted to in increased irritability of the nerves and muscles, irritative conditions in the sensory, motor, and vasomotor tracts, and also abnormal conditions of irritation in the central nervous system, *i.e.*, in neuralgia, spasms, *puncta dolorosa*, spinal irritation, headache, insomnia, hyperæsthesia of the acoustic nerve, angiospastic migraine and the like.

The methods employed to secure these effects are very simple. They are uncertain with the faradic current, concerning whose modifying effects very little is known; it is usually held that feeble faradic currents produce increased irritability while very powerful currents diminish the irritability. This has been inferred chiefly from pathological and therapeutical data.

Diminution of irritability is also secured in many cases by the so-called increasing induction current: the large, moist electrodes being held in one position, the faradic current is first allowed to pass in a very feeble current and then gradually increased to the greatest strength which may be tolerated; it is retained at this height for some time and then slowly diminished. This procedure may be repeated several times at one sitting.

The modifying effects can be obtained more positively by the galvanic current. To produce increased irritability, the Ca should be applied in a stabile manner with increasing strength and duration; even after the current is opened, a positive modification of irritability persists for some time. The stabile application of the anode is the most suitable method for diminishing irritability; increasing strength and duration of the current likewise produce an increase of the desired effect. But a new difficulty here arises; with the opening of the current, after the cessation of an-electrotonus, a considerable increase of irritability occurs, and thus puts in question the entire result of the previous application. We must endeavor to obviate this; as it seems to me, this can be done with considerable certainty by carefully and gradually diminishing the strength of the current until it has sunk to nil.

In discussing the individual forms of disease I will formulate more in detail the special modifications of this method of treatment. Among the modifying effects must be included those which Heidenhain has described under the term "refreshing action" of the galvanic current. It is best secured by ascending stabile currents, depends probably in great part upon the electrotonic action of the Ca, and may be employed in those cases in which exhaustion of the motor apparatus has developed from over-exertion, excesses, and the like.

However obscure the catalytic effects of the current may be, their existence and extremely manifold applicability are universally recognized.

I have previously described them in detail (Lecture VI., page 56) and need merely repeat in brief what is meant thereby: they are the effects upon the vasomotor nerves and blood-vessels, probably also on the lymphatic vessels and the lymph current; the effects upon osmotic processes,

molecular arrangements, movements of fluids in the tissues, the electrolytic and cataphoric effects, perhaps also the effects upon the trophic nerves—in short, the influences resulting from all these upon the processes of resorption and nutrition in general. In fact, a sum total of effects which must secure to the electrical current an extremely powerful and many-sided influence upon various morbid processes in the nervous system as well as in the other tissues of the body. Thus, in all inflammatory disturbances of an acute and chronic character (neuritis, myelitis, sclerosis, etc.), in the most varied exudative processes, in rheumatism of the joints, muscles, and nerves, extravasations of blood, all kinds of degenerative changes, palpable and impalpable nutritive disorders of the nervous system.

Although the existence of these effects cannot be denied, we are far from being able to secure them with certainty and equally far removed from designating those forms of disease in which it may be assumed that these catalytic effects will prove successful.

I will now mention a number of pathological and therapeutical observations which bespeak the existence and pathological significance of these catalytic effects and present, to a certain extent, a positive basis for the criticism and further investigation of this interesting question.

In the first place we may refer to the results of galvanic treatment in the various forms of neuritis. R. Remak mentions several cases of primary and secondary neuritis and also of neuritis nodosa in which the pain and swelling disappeared more or less rapidly upon application of the galvanic current: Mor. Meyer observed very rapid disappearance of neuritis of the median nerve, with perceptible swelling, under stable action of the anode, and lately reports similar results in traumatic neuritis and other forms. Fr. Fischer and I have reported similar cases.

The observations in arthritis of various kinds are more numerous. Remak mentions a number of brilliant results in acute and chronic rheumatic and traumatic affections of the joints, which leave scarcely a doubt of the decided antiphlogistic action of the galvanic current. Various other writers have described very favorable results in chronic exudations into the joints, and other diseases of this class.

M. Rosenthal observed several cases in which chronic exudations into the joints disappeared under galvanic treatment; Moritz Meyer reports several cases in which favorable results were obtained, partly by faradization, partly by galvanization; Cohen obtained good effects in true arthritis from persevering treatment with the rotatory apparatus, and similar success is reported by Chéron from the galvanic treatment of deforming articular rheumatism; Weisflog noticed striking results from local faradization of traumatic and scrofulous inflammations of the joints, and regards this current as "the most vigorous, unailing, and valuable antiphlogistic for all traumatic inflammations."

Furthermore, resolution and atrophy of glandular tumors have been repeatedly effected by electrical currents. Onimus and Legros mention one noteworthy case in which two symmetrical glandular tumors were present, one of which was treated with the An alone, the other with the Ca alone; the one treated with the An disappeared more rapidly.

Moritz Meyer has effected a separation and reduction in size of multiple, large, hard glandular tumors by the application of very strong, frequently interrupted faradic currents; Chvostek has treated many strumous growths with the stable galvanic current, and effected often a considerable diminution in their size, in some cases very rapidly and completely.

No less striking are the results which some observers have obtained in hard cicatrices, stiffness of the joints and periostoses after gunshot wounds, by means of the galvanic current.

Finally, observations have been made upon evident action of the current in contusions, extravasations of blood, subluxations, and inflammations. Remak saw a brilliant result in a sprain of the wrist-joint in which the swelling and stiffness rapidly disappeared. Chvostek relieved a chronic inflammatory, traumatic infiltration of the leg by means of labile galvanization of the nerve. Sycianko states that he repeatedly cured acute gingivitis in a remarkably short period by the action of the anode; and Chéron and Moreau-Wolf maintain that they have had very favorable results from the galvanic current in gonorrhœal and traumatic inflammations of the testicles, and in chronic hypertrophy of the prostate.

There can be no doubt that similar effects, though to a less degree, may be produced even in more deeply situated tissues, but it would lead us too far to mention all the observations of palpable diseases of the brain and spinal cord in which undoubted favorable results were obtained from the catalytic action of the electrical current.

At all events, there is no doubt that such action exists, though its more intimate character is still involved in great obscurity. Catalytic effects are produced in the main by the galvanic current, and upon this fact depends, no doubt, its great superiority to the faradic current, especially in the treatment of more deeply situated organs.

The best method of securing the catalytic effects of the galvanic current appears to be its stable passage through the diseased part (with sufficient strength and duration of the current). It is probably useful to alter the direction of the current several times, as the vasomotor, electrolytic, and cataphoric effects of the current are undoubtedly intensified thereby. The position of the electrodes depends entirely upon the situation and size of the diseased part: if we have to deal with a small neuritic nodule, it may be entirely covered with one electrode, the other being placed upon an indifferent part of the body; if we have to deal with a diseased joint or a morbid process in the brain, the electrodes are placed on each side of the diseased part.

You will naturally ask whether the two poles do not have different effects and whether one or the other does not deserve the preference in special cases; *a priori*, this view is very probable, but we possess no positive evidence of its correctness.

It is generally held that the application of the anode to the diseased part is preferable when there are symptoms of active irritation, more active processes, abundant collections of fluid, very painful affections;

while the cathode should be applied to more torpid, chronic processes, indurations, scleroses, etc. But as many data favor an opposite view, or, at least, seem to indicate that the polar effect comes less in question than the direct passage of the current, I have preferred, as a rule, to place both poles upon the diseased part, and then change the direction of the current several times, or, in the unipolar application, to allow first one pole and then the other to act.

From theoretical considerations Chvostek arrives at the conclusion that short and not too strong currents may alone be employed (about three to ten minutes); he attributes the catalytic effects chiefly to stimulation of the vasomotor and trophic nerves; he regards it as preferable to treat the diseased part directly, and not alone the corresponding nerves, in order to take advantage also of the electrolytic and cataphoric actions of the current.

In many cases it also appears useful, in addition to treatment of the diseased part itself, to make a stable and labile application to the adjacent parts—vessels, lymphatics, muscles, skin—in order to act indirectly upon the circulation and nutrition of the diseased parts; repeated interruptions of the current and even changes of polarity may be useful, in order to intensify the individual effects of the current, to relax tense muscles, etc.; these measures are especially advisable in the treatment of diseased joints.

The faradic current is much less effective for catalytic purposes; more or less powerful currents are simply passed directly through the diseased part. In the resolution of glandular tumors, M. Mayer has employed the faradic current in such a manner that the strongest possible current (with moist electrodes) is applied for a few minutes, frequent interruptions being made during this period; a distinct separation of the tumor into smaller parts occurs forthwith, and the tumors are gradually reduced very much in size. R. Remak has also described an indirect catalysis. It is said to consist in a modification of the circulatory and nutritive conditions of various tissues, produced by galvanization of the nerve-trunks supplying them. Remak states that he has seen galvanization of the nerves, remote from the site of disease, cause more rapid absorption of extravasations of blood, disappearance of articular swellings, increase in the size of atrophic muscles, etc.; he recommends the application of the anode to the nerve-trunk, as far as possible from the site of disease, as an especially certain remedy in relieving the pain of inflamed parts, joints, etc. It would be very desirable, however, that these isolated observations should be confirmed and multiplied in order to place the doctrine of indirect catalysis upon a surer basis of fact.

This question has assumed an unexpected importance from a series of statements and hypotheses concerning galvanization of the cervical sympathetic as a therapeutic method. It has been said that this method of

application influences the vasomotor and trophic processes of the brain and spinal cord, the face and eye, the muscles and joints, even the skin and other parts of the body. Numerous cures have been reported by this method in cerebral hemiplegia, trigeminal neuralgia, migraine, paralysis and spasms in the distribution of the facial nerve and in the ocular muscles, in bulbar paralysis; also in neuro-retinitis and atrophy of the optic nerve, Basedow's disease, epilepsy, progressive muscular atrophy and lead paralysis, arthritis deformans, scleroderma, and various other diseases of the skin.

There can probably be no doubt of the correctness of a part of these observations, but this does not by any means imply that the cervical sympathetic is responsible for such results. In the ordinary methods of galvanization of the sympathetic, numerous threads of current undoubtedly reach the pneumogastric, carotid, the nerves at the base of the skull, the brain, the brachial and cervical plexuses, but especially the cervical region of the spinal cord, and the medulla oblongata with their numerous important centres for the vessels, pupils, respiration, the heart, nutrition of the muscles and joints, etc.; it is a question whether these effects are not more important than those upon the sympathetic.

I attach no great significance to the fact that physiological experiments upon the cervical sympathetic of healthy individuals (page 51) have been so barren of results with regard to the therapeutic application of this method. In such matters experience can be our sole guide in practice. The negative results of physiological experiments, in opposition to positive therapeutic facts, should not prevent us from employing so-called galvanization of the sympathetic as a therapeutic measure and testing its value. I am in favor of employing the term "galvanization of the neck," instead of "galvanization of the sympathetic," or better still, the term "subaural galvanization" recommended by De Watteville.

The most serviceable method of application is that recommended by Mor. Meyer; one pole (a "medium" electrode) is applied under the angle of the lower jaw on one side, immediately adjacent to the hyoid bone, and is pressed backward and upward against the vertebral column; the other somewhat larger electrode is applied to the opposite side of the neck near the spinous processes of the fifth to seventh vertebrae. The Ca is usually placed in the former position (region of the superior cervical ganglion). The employment of moderately strong currents is usually sufficient (6 to 10 Stoehrer's elements), a stable current is generally used, but labile and interrupted currents, even changes of polarity, are sometimes indicated. The duration of the application need not, as a rule, exceed one to three minutes. According to the circumstances of the case it is made unilaterally or bilaterally.

Benedict places a button-shaped An in the jugular fossa, the Ca upon the superior cervical ganglion; for anatomical and physical reasons this method is not as serviceable as the one just mentioned.

Finally, I will make a few remarks concerning certain reflex effects of electrical currents; I refer to changes in the vessels of the brain and spinal cord from faradic or other irritation of the skin and peripheral nerve-trunks. Contraction and dilatation of the vessels of the pia mater in the brain and cord have been observed, though not constantly, after irritation of peripheral nerves and organs. Probably a part of the results of peripheral electrization in diseases of the central organs must be attributed to such effects, and Rumpf has recently described a few cases in which peripheral cutaneous faradization apparently had a very favorable influence upon central hyperæmias, optic neuritis, locomotor ataxia, etc. The method employed by him consisted of slow stroking of a faradic brush to the chest, back and arms, with a moderate current, the sitting lasting five to six minutes.

From the above considerations you readily see that our theoretical views concerning the therapeutic applications of electricity are still defective and insufficient. We are confronted by a number of problems, toward whose solution merely the first steps have been taken; our most important problem still is to develop electro-therapeutics by empirical means. We may console ourselves, however, by the undoubted practical results which are achieved and by a glance at other branches of therapeutics and our ignorance of the method of action of the most valued remedies. Are we not unacquainted with the manner in which quinine relieves chills and fever, in which salicylic acid relieves acute articular rheumatism, and iodide of potassium tertiary syphilis? And so in electro-therapeutics the number of our successes should spur us on to continued investigation.

LECTURE XIII.

Methods of Therapeutic Applications in Local Diseases—Polar or Direction Method?—
Advantages of the Polar Method—Empirical Methods—Influence upon the General Organism : 1. General Faradization (according to Beard and Rockwell) ; 2. General Galvanization ; 3. Central Galvanization (Beard) ; 4. The Electrical Bath—**Special Methods of Treatment :** 1. Galvanic Treatment of Pressure and Painful Points ; 2. Treatment with Feeble, Continuous, Galvanic Currents.

A LIVELY dispute has arisen with regard to the question whether the direction of the current or the polar action should be taken as the general basis for the method of application.

Brenner first developed the well-founded polar method, according to which the action of the individual poles, and therefore the localization of one or the other pole upon the diseased part was decisive for the electro-therapeutic method.

Neither of these two methods was applicable with strict consistency, and theoretical considerations alone were opposed exclusively to one or the other ; indeed, a superficial glance sufficed to show that certain fields of the electro-therapeutic effects were very little or not at all affected by this dispute. What could be accomplished, for example, by the direction of the current in the treatment of glandular tumors, struma, joint inflammations and the like ?

It is, however, a matter of some interest to us to enter into this question and to weigh the arguments for both methods, pro and con, in order to form a decided opinion for our future conduct.

With regard to the direction of the current we know, in the first place, that in the majority of cases it is impossible to pass the current effectively in a definite direction through a nerve of the uninjured body, but that necessarily at least three different directions of the current (of rapidly diminishing density) must be present ; this has previously (page 37) been proven in detail. The only conceivable method of application by which one definite direction of the current is possible, at least in some parts of the nerves, viz., that in which the current is conducted from the end of a limb (hand or foot) to a more central part of the extremity or to the trunk, would only suffice for the peripheral halves of the nerves ; but careful consideration will show that in the neighborhood of the central electrode (centrally from it, especially when placed on the trunk) diffused currents of varying direction are unavoidable ; this method of application, in

addition, would be applicable only in the fewest cases. The advocates of the "direction" method must therefore devise other modes of application in order to bring the direction of the current exclusively into action.

Furthermore, all proof is lacking that the direction of the current is at all an essential factor in its action. On the contrary, the investigations of physiologists have proven that all the known effects of the current (stimulating, modifying, electrolytic, etc.) are exclusively polar effects, and come into play in any direction of the current (with the single exception of its strictly transverse passage). In fact, the direction of the current appears to be devoid of any decisive influence upon the occurrence of the polar effects. In only a few definite cases (third stage of Pflueger's law of contraction) is the conduction of the, nevertheless developing, irritative process inhibited in one or the other direction; but this cannot surely be interpreted as a "direction" effect. It is decisive in this respect, that the inhibition of conduction occurs sometimes with ascending, sometimes with descending currents, that it occurs in the sensory nerves in an opposite direction of the current to that in the motor nerves, and that it may be attributed to certain polar effects.

There appears, therefore, to be no reason for making the direction of the current the basis of our method of application; at all events, there is no scientific necessity for it, although a regard to technical practicability and, in some cases, certain surmises may induce us to employ such a method.

On the other hand, there are very weighty reasons for preferring the polar method, reasons of a physiological and physico-technical character, but also those which result from therapeutical experience.

In the first place, physiology has shown that all the recognized, therapeutically useful actions of the current are exclusively polar effects, and appear to be associated with the vicinity of one or the other pole; in general, all effects of the current are most intense in the immediate vicinity of the pole.

In the second place, it is technically much easier to subject any desired part of the body to the most intense possible action of one or the other pole, than to cause a definite direction of the current of uniform intensity. With the aid of accurate anatomical knowledge and the proper choice of the active and indifferent electrodes, this purpose can almost always be effected with readiness and certainty. One serious objection, however, cannot be escaped; an exclusive action of one pole upon a definite part is impossible, as we have previously seen; the effect of the other pole must always be present at the same time. But if you will remember how the currents are diffused, what a slight degree of density, and therefore of activity, they must have in by far the majority of cases, it will not be difficult for you to believe that the action of the "active" pole must be extremely predominant, in comparison with which the secondary polar

action may, in the majority of cases, be neglected ; furthermore, the latter may be diminished by suitable manipulation and the primary polar action be allowed to affect the nerve in an increased measure.

In addition, there are a certain number of therapeutical data which furnish proof of the efficacy of the polar method. The most striking are the facts observed with regard to nervous tinnitus aurium and hyperæsthesia of the acoustic nerve ; in these cases the pole indicated by the formula of galvanic reaction usually proves highly effective in the relief of the tinnitus as well as in the diminution of the hyperæsthesia, while the other pole is ineffective or even injurious. Holst has developed a galvanic treatment of migraine according to the principles of the polar method, and the successful results corresponded to his assumptions ; O. Berger ascribes brilliant results in trigeminal neuralgia to the application of the strict polar method (stable application of the An) ; Althaus has successfully employed the polar method in toothache and also in other neuralgias.

But the decisive feature in this question must be the main purpose, according to our present knowledge, of all electrical treatment, viz., to subject the diseased part as certainly and as intensely as possible (avoiding all injurious auxiliary effects) to the action of a current of sufficient density.

As we are unfortunately ignorant, in the majority of cases, of the manner in which the electrical current acts, we must at least see to it that it does or may act.

But, in the end, experience alone can teach us whether one pole (and which one) will prove especially effective ; *a priori* we will only be able to predict this with certainty in a limited number of cases. We should not be astonished if phenomena are occasionally observed which are opposed to our theories. In not a few cases you will find both poles effective in a similar manner, and, especially in the production of catalytic effects, it has hitherto proved impossible to give the preference to one or the other pole and to define their effects more accurately.

From all that has been said it appears probable that the direction of the current does not possess great influence upon any therapeutic result, but this is by no means proven. In this matter, also, further experience must decide the question. In many cases, indeed, a definite direction of the current may be useful to facilitate the action of one or the other pole, but this is only done in the service of the polar method.

It is evident that we have to deal in the main with empirical methods. I cannot warn you too strongly against illusions based upon theoretical views or against therapeutical illusions founded upon uncontrolled observations. Electro-therapeutic literature swarms with such instances and the defective criticism of observations has led to innumerable, unsuspected deceptions.

The remarks which have been previously made hold good essentially with regard to the local treatment of local diseases.

But mention must be made also of a few other measures whose object it is to influence the entire organism—methods which have been devised to combat certain forms of disease in which there is a general disturbance of the entire nervous system (as in various forms of neurasthenia, hysteria, hypochondria, etc.), or in which an affection of the blood and nutrition produces general weakness of the organism (anæmia, chlorosis with its nervous disorders, general muscular weakness, etc.); or, finally, those forms of disease in which we endeavor by stimulation of the entire organism, especially the muscular system and skin, or by an electrical influence upon the entire nervous system, to combat wide-spread, deeply seated, or certain peculiar disturbances (general weakness, hysteria, diffuse vasomotor paresis, diffuse affection of the skin, multiple diseases of the joints, etc.). There is no doubt that favorable results are often obtained by these methods.

1. *General faradization* (first employed by Beard and Rockwell). It purposes the most general faradic stimulation possible of the entire organism, with special preference of the central nervous system, the muscular system, and the skin.



FIG. 26.—Large round sponge electrode with short handle, used in general faradization. Half the natural size.

The following is the method; the patient, undressed in great part or lightly clothed, is seated upon a chair, the bare feet being placed upon a large, flat, well-moistened electrode (or in a vessel filled with lukewarm water), which is connected with the Ca of the secondary coil. The Anode is either formed by the moist hand of the physician (who takes the electrode in the other hand and allows the current to pass through his own body), or, better still, by a large sponge-covered electrode (5 to 8 ctm. diameter) (Fig. 26), which is brought in contact, as far as possible, with all parts of the body. In sensitive persons the “electrical hand” is advisable in applications to the forehead, head, and anterior parts of the neck, because the physician then has an excellent gauge of the strength of the current and because this method of application is very mild on account of the great adaptability of the hand.

We begin with the forehead, allowing a distinctly perceptible current to pass through it and the temples, and then pass to the vertex, where the An is allowed to remain for some time; a somewhat stronger current is then applied to the occiput and back of the neck; a still stronger current is then applied for some time along the spinal column, along which the electrode is slowly moved up and down, being kept a little longer upon special points, such as painful spinous processes; this is followed by fara-

dization of the neck (with a weaker current) in order to stimulate the sympathetic, pneumogastric, and phrenic nerves and the muscles of the neck; then the anterior surface of the chest, especially the cardiac region, and the abdomen are faradized with more vigorous currents; the An may remain for some time upon the epigastrium in order to affect the cœliac plexus, and is then slowly passed over the entire abdomen in order to stimulate intestinal action and the abdominal muscles; finally, the muscles and skin of the back and all four extremities are vigorously stimulated in succession; the electrode is forcibly drawn over all these parts, especially the main nerve-trunks and muscles, with such a strong current that active muscular contractions develop everywhere; at the close, the spine may undergo a second brief application.

The entire procedure should occupy about ten to twenty minutes, and must naturally be varied extremely in intensity, duration and the special localizations of the current in different individuals and forms of disease.

Beard and Rockwell ascribe to this method the following effects: the immediate effect, as a rule, is refreshing and stimulating; pains, general weakness, etc., disappear temporarily; the pulse is regulated; in very sensitive persons, dizziness, nausea, trembling, feeling of faintness may develop. Within one to three days after the application certain reactive symptoms may occur—muscular pains, increased nervousness, headache, insomnia, etc.

The permanent effects usually consist of improved sleep, increased appetite, improved digestion, increase in the size and firmness of the muscles, relief of pain and dulness in the head, etc., diminution of nervousness and depression. Beard and Rockwell attribute these effects to direct electrical stimulation of the entire central nervous system and the frequently repeated vigorous muscular contractions during the applications.

According to these writers, this method is indicated especially in "constitutional diseases," in all forms of disease associated with general feebleness of nutrition and the vital functions (for example, in neurasthenia, hysteria, hypochondriasis, nervous dyspepsia, anæmia and chlorosis, paralysis and neuralgia from constitutional causes, furthermore in certain functional disorders of the sexual and digestive organs); also in morbid symptoms, whose probably local cause cannot be recognized (as in many cases of neuralgia and paralysis, epilepsy, hysteria, etc.); finally, in diseases which, though themselves incurable, are associated with general feebleness of nutrition and other symptoms (insomnia, nervousness, weakness, etc.), which may be relieved.

I have employed general faradization with sufficient frequency to satisfy myself of its decidedly favorable effects.

2. *General galvanization* is the exact analogue of the previous method, except that the galvanic current is employed; the Ca is applied to the feet, and the An manipulated upon the body of the patient in the manner

which I have described for general faradization. The effects are said to be similar, but greater caution must be employed in applications to the central nervous system.

3. *Central galvanization.* A large flat Ca is placed upon the epigastrium, while the An is applied by means of a large, round sponge-electrode to the head, the sympathetic, and along the entire spinal column. The forehead is first stroked gently from one side to the other with a feeble current (2 to 8 elements), and then an application made for one to two minutes to the centre of the skull; the An is then moved up and down for one to five minutes along the sympathetics and pneumogastriacs in the neck, finally in the same manner along the entire spinal column for three to six minutes.

This method is said to be especially applicable in those neuroses in which the general nutrition and muscular power are relatively intact. Beard states that he has seen brilliant results from it in hysteria, hypochondriasis, chorea, cerebral and spinal neurasthenia, gastralgia, nervous dyspepsia, etc.

I have employed this method in a few cases, without observing any notable result, but I do not consider this a sufficient test. The results reported by Beard are so remarkable that we are justified in expecting from their confirmation the solution of various theoretically important questions.

4. Finally, I will briefly mention another method of general electrization of the body viz., *the electrical bath.*

In one variety, the metallic bath-tub is connected with one pole while the other pole is grasped by the hands of the patient. Care must be taken that the body of the patient does not come in actual contact with the metal of the bath-tub; this object is secured either by means of a wooden support or by some other arrangement which supports the body in the water.

In another form, the bath-tub consists of a non-conductor, and the electrodes are placed in the water. The individual parts of the body will be subjected more or less intensely to the action of the current, according to their approximation to the electrodes. In order to introduce the greatest possible quantity of electricity into the bath, very large electrodes should be employed, or an addition of salt, soda, or acid may be made to the water used in the bath.

The temperature of these baths may be varied according to the general indications of the case, and this is also true of the strength of the current to be employed; usually at least a slight sensation of the current should be felt. The duration of the bath varies from ten to thirty minutes.

Local electrical baths have also been employed, one electrode being represented by a basin of water in which the diseased part is immersed.

A priori, it cannot be denied that the electrical bath may produce very marked effects, but the therapeutical experiences hitherto obtained are not calculated to inspire great faith in its efficacy. It appears to have been

most successful in certain forms of tremor, especially mercurial and alcoholic tremor, then in chronic articular rheumatism, in cerebral neurasthenia.

In conclusion I will refer to two other methods of treatment which are capable of general application.

1. The first is the galvanic treatment of pressure and painful points, *i.e.*, of pressure points which, perhaps more or less painless in themselves, have an evident effect upon the production or relief of neuralgias and spasms; or of painful points which are revealed by pressure with the finger or electrical examination and are found associated with the other symptoms of spasms, neuralgia, locomotor ataxia, and the like, without producing upon pressure any notable influence upon the momentary condition of the symptoms.

R. Remak found these points upon or near the spinal column in some neuralgias, and also in the neuralgiform pains of ataxics, and often observed a magical sedative influence from the stable application of the An to these points. He also observed this in many forms of spasm, especially facial spasm, when he directed the current to points, pressure upon which produced inhibition or increase of the spasm, and which were often found more or less remote from the affected nerve-trunk, especially upon the spine. Onimus and Legros report similar observations in ataxia. Mor. Meyer found these painful pressure points, in a large number of neuroses, upon the spine (the spinous processes, more frequently the transverse processes). He believes that they are due to various anatomical lesions (periostitis, neuritis, small glandular tumors, inflammatory exudations, etc.) and often produce and maintain the neurotic symptoms; he has found that their galvanic treatment with the An is an excellent therapeutic remedy in neuralgia, spasms (chorea, writer's spasms), and even in ataxia. He has recently observed such pressure points in the nerve plexuses or other parts of the course of the nerve, and has corroborated his former experience with regard to the favorable action of the An. He recommends beginning the treatment with weak currents (4 to 8 elements).

Brenner has found such painful points upon the spine by passing the Ca (of a mild current) down the vertebral column. Upon passing over some points the patients experienced intense pain, and persistent application of the An to these parts causes them to disappear gradually, and usually leads to relief of the neuralgia, disappearance of the cincture feeling, and marked improvement of the ataxia.

I have not detected similar phenomena, except in rare cases of ataxia.

The best method of treating these points appears to be the stable application of the An, with feeble or moderately strong currents. The Ca may be applied to an indifferent spot or to more peripheral painful points, according to the circumstances of the case; the application should be continued from one to five minutes.

2. The other method is that of treatment with very feeble but very protracted uninterrupted galvanic currents. Currents of one or two, at the most four, elements are applied to the diseased part continuously for hours, or even for days and weeks.

Among more recent writers Ciniselli was the first to recommend the application of a "simple element" (a zinc or copper plate, connected by an insulated wire, *vide* Fig. 27) to the skin for the relief of various nervous affections. The plates may be of various sizes, must be thin and flexible, brightly polished before each application, and are fastened to the desired spot by means of adhesive plaster or a bandage. Their action is intensified by applying to the plates a piece of linen, which is kept continually moistened by a solution of salt or acid.

These plates must be applied several hours a day, or even continuously for days and weeks. If the skin is very sensitive, inflammation and pustules may develop beneath the plates; their point of application must

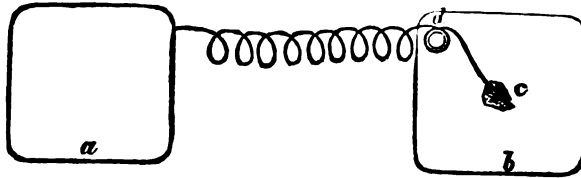

FIG. 27.—"Simple element" according to Ciniselli. *a*, Zinc plate (anterior aspect); *b*, copper plate (posterior aspect), connection by means of an insulated copper wire; *c*, point at which the wire is soldered; *d*, small button around which the wire is wound to prevent breaking.

then be changed often, and the period of employment diminished. Ciniselli found such apparatus serviceable in neuralgia, paralysis, headaches, and the like.

Le Fort's method consists in the application of a current from two to, at most, four elements, which is conveyed to the diseased part by means of ordinary electrodes, and is employed for days and weeks, either continuously or with short intermissions. Le Fort considers these weak currents indicated in all paralyzes and pareses with simple or fatty atrophy of the muscles, in reflex paralysis from contusions, in all conditions of poor nutrition of the muscles, and finally in contractures.

Valtat has obtained striking results from this method in the atrophies, pareses, and paralyzes of muscles which are so extremely frequent after joint affections. The treatment should be instituted after the acute inflammatory stage has ceased and a chronic condition developed. At a later period, fradization of the muscles may also be employed. I have also obtained some good results from this method; it was especially successful in a number of cases of severe hysterical neurasthenia of delicate women with marked muscular weakness, and in whom the element was applied several hours daily to the back. It is difficult to determine, however, how much is accomplished by psychical influence.

LECTURE XIV.

General Principles and Special Technical Recommendations for Electrical Treatment
—Treatment in *Loco Morbi*—Technique of the Localization of the Current—
Local Faradization of the Motor Nerves and the Muscles—Plan of Treatment—
Personal Acquaintance with the Effects of the Current—Choice of the Strength
of the Current—Choice and Management of the Electrodes—Avoidance of un-
necessary Irritative Effects—Duration and Frequency of the Individual Applica-
tions—Entire Duration of Treatment.

BEFORE I pass to the special part—to the explanation of the electro-
therapeutic indications and methods of application in the individual forms
of disease—I desire to present a series of general principles, and also a
number of special technical recommendations.

I believe that the most important principle is the treatment in *loco morbi*—*i.e.*, the application of the electricity to the diseased part itself. There can be no doubt that, in the overwhelming majority of cases, it is best to act directly upon the site of the disease.

Unfortunately, this rule is limited by the restrictions of our diagnostic ability. How often we are in doubt with regard to the accurate localization of nervous disorders every experienced neuro-pathologist knows. In cases of diagnostic uncertainty with regard to localization nothing remains but the systematic successive application of the current to the various possible localizations; in these attempts it is well to advance from the periphery toward the central organ.

There is an apparent exception to this principle in the attempt to influence certain affections in an indirect way; for example, by employing reflex paths, by indirect catalysis, by so-called galvanization of the sympathetic. In these instances, however, we also endeavor to reach the site of the disease, although in a roundabout manner.

In certain cases of more diffuse or general neuroses, of constitutional or similar diseases, local electrical treatment naturally must be discarded; we then resort to general faradization and galvanization, etc., which have been previously described.

The necessary consequence of the principle just enunciated is the furtherance of the most accurate technique in the localization of the current.

For this purpose you need, above all, a knowledge of physics, especially a practical acquaintance with Ohm's laws. You must clearly understand where and how the electrodes must be applied, how large they

must be, the strength of current to be employed, in order to bring a definite part of the body under the desired influence of the current.

In addition, you must possess accurate anatomical knowledge with regard to the position of the individual parts, especially of the nervous system, and the relation of the deeper parts to the surface of the body.

I will present to you a short schematic sketch of "local faradization" of the motor nerves and the muscles, explained by a few illustrations and short practical remarks.

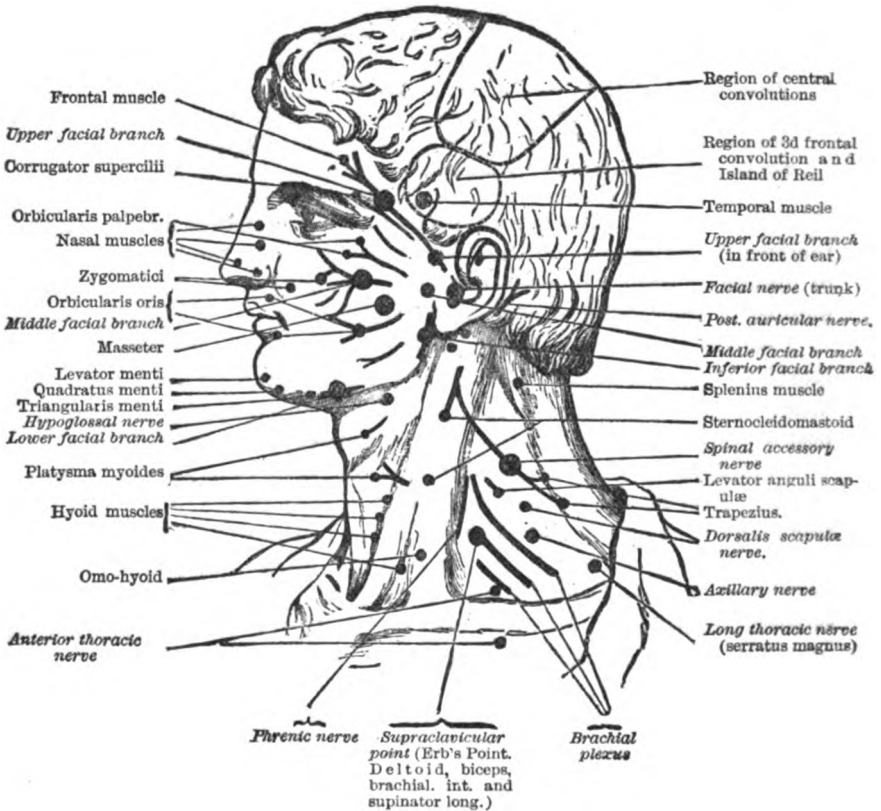

FIG. 28.

On the head (*vide* Fig. 28) the distribution of the facial nerve is the most important, and this nerve is also very readily stimulated. The illustration gives an approximate idea of the situation of the facial branches; the darker points indicate the chief positions of stimulation. In careful investigations the trunk of the nerve should first be sought: this is best done with a fine electrode, which is firmly pressed immediately below the external auditory canal, from behind and outward anteriorly and inwardly and upward against the edge of the lower jaw. It may also be reached in the external auditory canal, a fine electrode being pressed inward, downward, and forward from without and above.

For accurate comparative examinations I divide the nerve into three main branches, and examine these in two positions, immediately in front of the ear and also about the middle of their course. The upper branch is distributed to the muscles above the palpebral fissure; the middle branch to the muscles in front of the upper jaw, between the palpebral and oral fissures; the lower branch to the muscles upon the lower jaw. The points of irritation for examination in front of the ear are found upon the malar bone, immediately below it, and finally at the edge of the ascending ramus of the jaw (*vide* the figure).

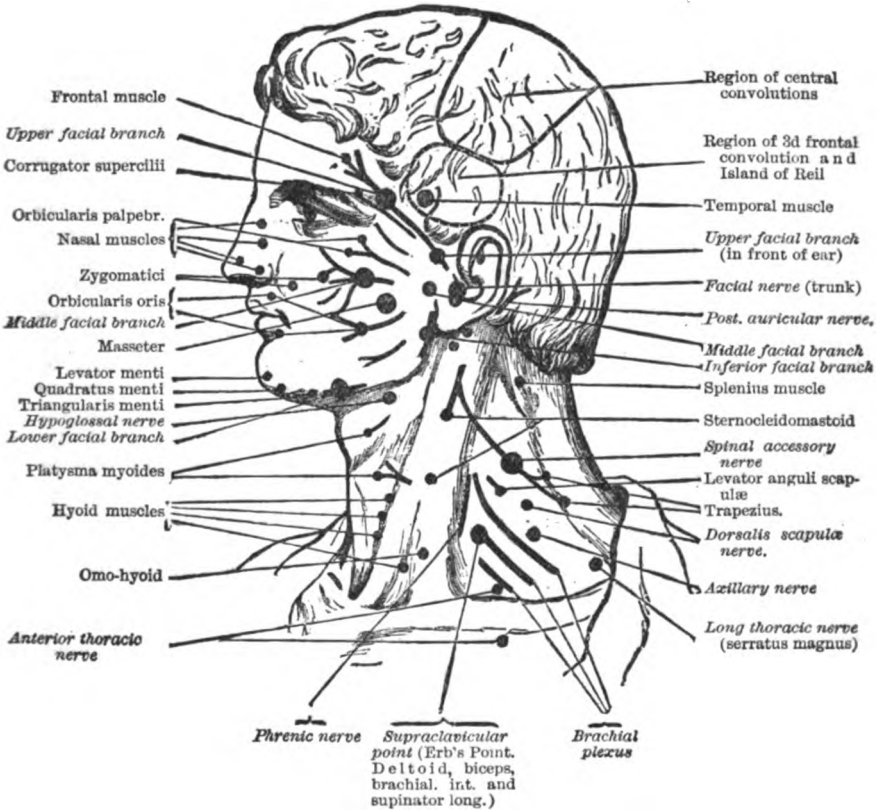

FIG. 29.

The points of irritation in the middle of the course of the nerves are three in number: at the temple, at the anterior angle of the malar bone upon its lower border, and finally in the middle of the lower border of the horizontal ramus of the jaw.

The situation of the motor points of the muscles is evident from the figure; they must be determined with very fine electrodes, lightly applied, with the weakest possible current.

The ocular muscles are not accessible to electrical irritation.

The muscles of mastication are accessible only upon direct stimulation with a vigorous current in the positions given upon the figure.

The occipital and posterior auricular muscles can be readily stimulated upon the mastoid process by the posterior auricular nerve.

The hypoglossal nerve may be stimulated in many persons by a vigorous current applied immediately behind and above the hyoid bone, a fine electrode being used and pressed in deeply; its effect is contraction, distortion, etc., of the corresponding half of the tongue. Direct stimulation of the tongue, velum palati and upper muscles of the pharynx can be readily performed with a suitable electrode.

The spinal accessory nerve is stimulated with facility in a great part of its course; the large dot in the middle indicates approximately its most irritable part. The sterno-mastoid and trapezius muscles are readily stimulated separately.

Numerous nerve-trunks and motor-points are situated in close proximity in the supraclavicular fossa, viz., the brachial plexus with all its branches and the phrenic nerve. The latter can with difficulty be stimulated separately; this must be done with a fine electrode, in order to avoid the adjacent nerve-trunks. The nerve is situated quite superficially at the posterior border of the sternomastoid; the effect of its irritation is a sudden inspiratory movement, protrusion of the epigastrium, associated with an inspiratory laryngeal murmur. The effect is most marked upon bilateral irritation with a branched electrode. Artificial respiration in asphyxia by means of rhythmical faradization of the phrenic nerves is best effected by bilateral irritation with broad, flat sponge-electrodes (Ca) (the An being placed upon the sternum or epigastrium), partly to make sure of reaching the phrenics, partly to stimulate also the branches of the brachial plexus and thus cause the auxiliary muscles of respiration to be brought into action; the head, shoulders and arms should be fixed by assistants. The vigorous faradic current is closed for one to two seconds, then opened for the same length of time, expiration being aided at the same time by means of vigorous pressure upon the abdomen.

With some care the individual branches of the brachial plexus are readily stimulated separately, especially in lean individuals; the upper extremity may be partly elevated and the head turned slightly toward the other side. The axillary nerve (contraction of the deltoid) can be found in the upper part, the posterior thoracic nerve (contraction of the rhomboids, etc.) somewhat more posteriorly, the long thoracic nerve (the serratus magnus muscle) more inferiorly and externally. The anterior thoracic nerve is found immediately above and below the clavicle and somewhat internally. Finally, from a circumscribed point, about two to three centimetres above the clavicle, somewhat outside of the posterior border of the sternomastoid and immediately in front of the transverse process of the sixth cervical vertebra, simultaneous contraction may be produced in the deltoid, biceps, brachialis anticus, and supinator longus muscles (supraclavicular point).

In the arm (Fig. 30) the median and ulnar nerves are stimulated with readiness in their entire course along the internal bicipital sulcus; the most irritable point of the ulnar nerve is a little above the inner condyle, of the median nerve at the elbow. The best position for the stimulation of these nerves is slight flexion as in the illustration, with relaxation of all the muscles. The effects of ulnar stimulation are: ulnar flexion and adduction of the hand, flexion of the last three fingers, adduction of the thumb. The effects of stimulation of the median nerve are: marked pro-

nation of the forearm, flexion of the wrist, closure of the hand, contraction of the thenar muscles.

The musculo-cutaneous nerve is readily reached, with a fine electrode,

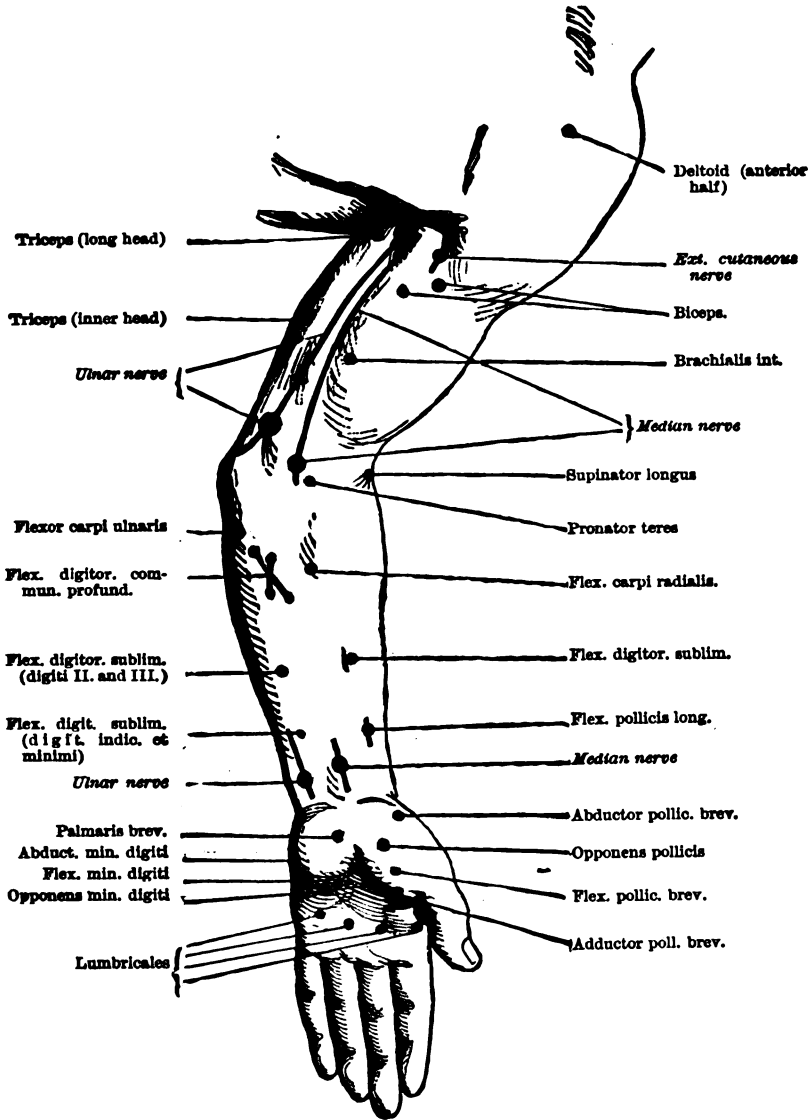

FIG. 30.

between the coraco-brachialis and biceps muscles. In the forearm the two main nerve-trunks are readily found above the wrist; the most irritable points are indicated on Fig. 30. The motor points of the muscles are also indicated in the illustration and are readily detected.

Upon the extensor aspect of the upper extremity the radial nerve is the most important and quite difficult to stimulate; it should be looked for about the middle of a line connecting the insertion of the deltoid and the external condyle; a fine electrode is pressed deep between the triceps and brachialis anticus against the bone and only a small spot is found here which is readily irritated. The effect of this stimulation is marked

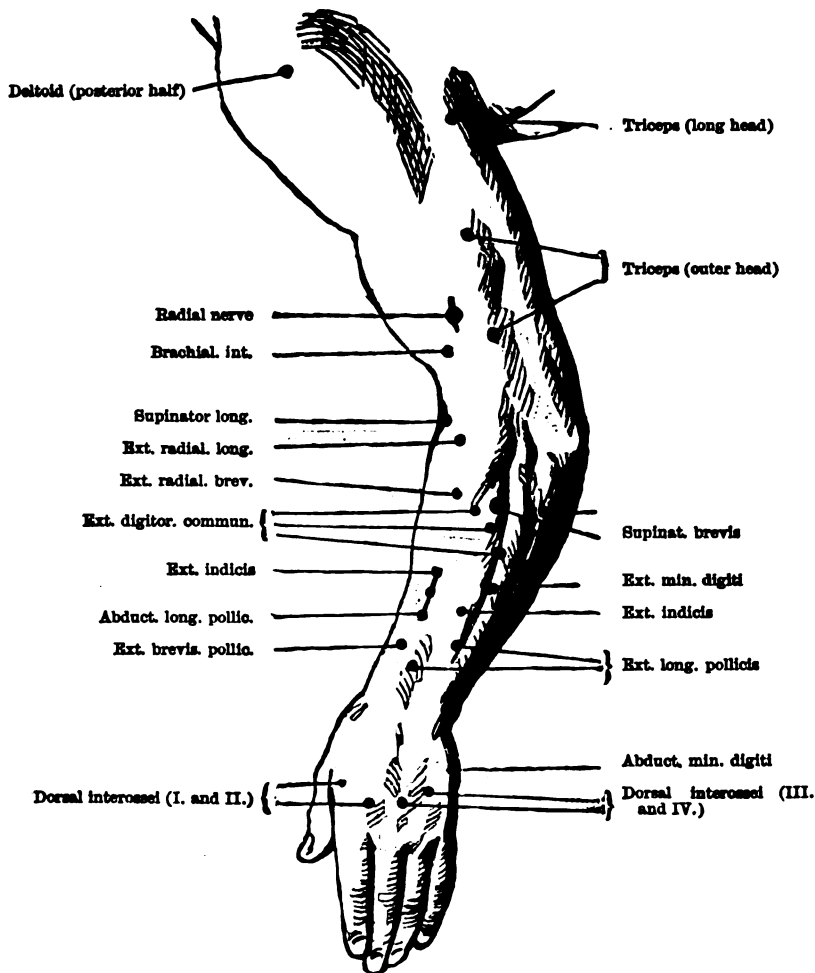

FIG. 31.

extension of the wrist, extension of the first phalanges, separation of the fingers, abduction of the thumb.

Apart from this, only muscular points are found upon the extensor aspect of the arm and these are indicated on the figure. Upon the trunk the muscles can only be stimulated by direct irritation of the individual muscles.

The anterior aspect of the thigh presents simple relations (Fig. 32). The crural nerve is immediately adjacent to and somewhat outside of the vessels of the thigh; it is well to press the electrode toward the pelvis and employ a strong current. The effect is contraction of the quadriceps and sartorius and extension of the leg. The obturator nerve is reached by pressing upon the point indicated in the figure, deeply between the muscles and toward the pelvis. The individual muscles can generally be stimulated quite readily.

Upon the posterior aspect of the thigh (Fig. 33) the gluteus maximus can be made to contract by direct stimulation alone. The trunk of the

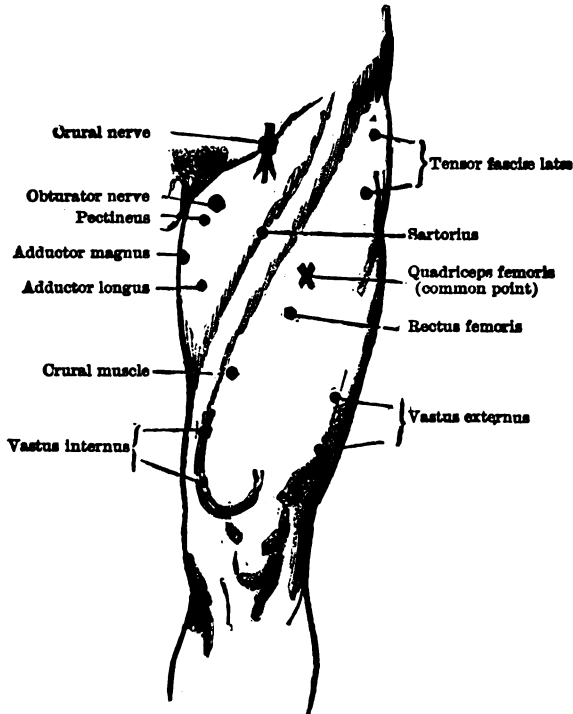

FIG. 32.

sciatic nerve is best stimulated at the lower border of the gluteus, the electrode being pressed in firmly with a very strong current. In the popliteal space its terminal branches are easily reached. The tibial nerve is exactly in the middle, its most irritable point being in the principal transverse fold. Effect of its stimulation: contraction of the calf, strong plantar flexion of the foot, flexion of the toes. The peroneal nerve is more to the outside, its most irritable point being in the same transverse fold. Effect: strong dorsal flexion of the foot, more or less marked abduction or adduction, extension of the toes.

The muscles of the posterior aspect of the thigh are stimulated with difficulty; it is advisable to keep the leg passively flexed during the ap-

plication ; contraction may be produced most readily in the neighborhood of the points shown on the figure.

In the leg we can, in the main, merely stimulate the muscles directly from the motor points ; in the thigh the motor points of the gastrocnemius and soleus can be found readily, the latter being irritable only at its edges in various places. Lower and to the inside is found the motor point of the flexor digitorum communis longus, to the outside that of the

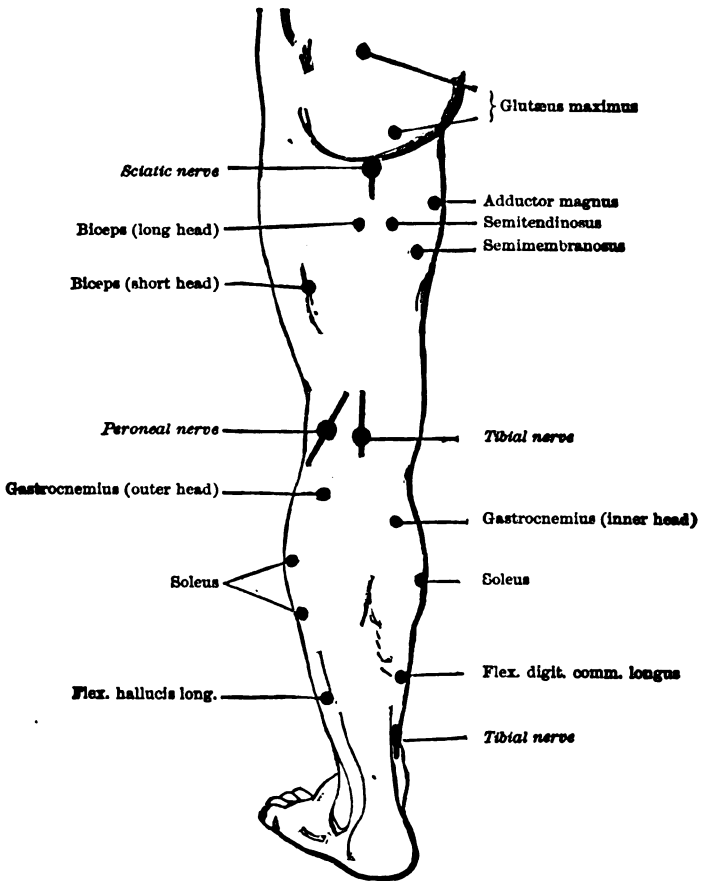

FIG. 33.

flexor hallucis longus ; still lower, to the inside of the tendo Achillis, the tibial nerve, from which a contraction of all the plantar muscles may be secured. On the anterior aspect of the leg the trunk of the peroneal nerve can be stimulated above at the head of the fibula.

The motor points of the tibialis anticus, extensor digitorum longus, and peroneus longus are situated at about the same height and require tolerably strong currents ; farther down to the outside is the motor point of the peroneus brevis, still lower, near the edge of the tibia, that of the ex-

tensor hallucis longus. Upon the dorsum of the foot, the extensor digitorum brevis, abductor minimi digiti, and dorsal interossei are readily stimulated.

The localization of the current in other parts of the body can be readily determined by a careful consideration of the anatomical relations. With regard to the skull it is important to know accurately the projection of the individual parts of the brain upon the surface. Thus, for example, the

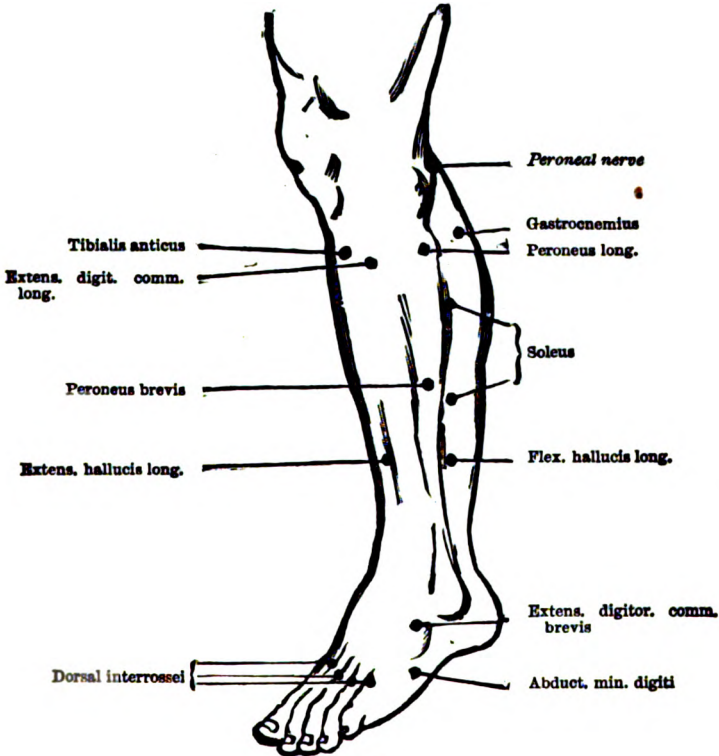

FIG. 34.

region of the third frontal convolution (speech centre) is somewhat in front of and above the ear (*vide* Figs. 28 and 29); the region of the central convolutions extends from this part backward to the vertex; the medulla oblongata lies between the mastoid processes and the two auriculo-mastoid fossæ; the large basal ganglia are situated between the temples, etc. I have previously described the position of the superior cervical ganglion in the neck; the lower one may be sought with a broad electrode next to the sterno-mastoid above the clavicle, the other electrode being placed upon the dorsal spine.

In every individual case which comes under your care, you should first

form a definite plan of treatment. This method should be pursued for some time, and if its inefficiency is then distinctly shown you may adopt another plan.

I consider an accurate personal knowledge of the effects and strengths of the currents as indispensable for every practical electro-therapeutist. Make frequent experiments upon your own body, determine the law of contraction of your various nerves, faradize all the nerves and muscles of your body which can be reached, determine the sensations produced by various strengths of current upon different parts of the body, etc. ! In this manner you will learn how to produce any desired action with the least possible irritant effect.

It is advisable not to begin with too strong currents. The strength of the current should be first tested upon your own face or hand. If you at once attack a patient with a very strong current you may frighten him and destroy his confidence. The best means of possessing constant control over the strength of the current is undoubtedly the presence of a galvanometer in the circuit of closure. The strength of the current may also be gauged approximately by the intensity of the sensation of burning of the skin produced by application of the electrodes.

It is especially important to employ only mild currents upon the head (with the exception of certain cases of aural disease). Sudden interruptions or reversal of the current should be avoided in this locality, unless rendered necessary for special reasons.

In the employment of the galvanic current use the largest possible electrodes (unless some special purpose necessitates small ones) permitted by the anatomical relations of the parts and their applicability. They should be kept thoroughly moistened by dipping them in hot water. Apply the electrodes firmly to the parts, especially when operating with strong currents. There is nothing more disagreeable to the patient than the sudden and repeated electrical shocks which occur when the electrodes are applied unsteadily.

Avoid all unnecessary irritation ; do not make any interruptions or changes of polarity, if not required. This rule is to be especially observed in the treatment of the central nervous system, the production of certain catalytic effects, in neuralgias, etc.

The duration of the individual applications and sittings is a not unimportant question. Almost all the later electro-therapeutists are agreed that short sittings are as effective as long ones, if not more so. There are naturally not a few exceptions, as in the local treatment of chronic articular rheumatism, in the production of energetic catalytic effects, in general electrization and the like.

In ordinary cases, each individual application, *i.e.*, to a certain part, should last from one-half to two, at the most eight minutes, and the entire sitting from two to ten, at the outside fifteen minutes.

No general rules can be laid down with regard to the frequency of the repetition of the sittings. One sitting daily is preferable as a rule, and a larger number are rarely necessary. In many cases which run a chronic course two to four sittings a week will suffice.

Very little can be said with regard to the duration of treatment; in chronic cases it is best to continue treatment so long as good results are visible or may be expected. If this is not the case, the treatment should be interrupted, but repeated, as a rule, after a certain lapse of time. You will not infrequently observe a more rapid and vigorous action after such intermissions.

In general it may be said that such chronic cases should be treated from two to six months, then an interval of equal length allowed to elapse, which may be filled in serviceably by other methods of treatment (baths, climatic cures, massage, etc.), or two to three series of forty to sixty sittings (daily or every other day) are held every year. In this manner obstinate cases of infantile spinal paralysis, tabes, chronic myelitis, spastic spinal paralysis, old hemiplegia, hysteria, neurasthenia, etc., may be treated with advantage for a number of years. Of course this will depend more upon external circumstances, the pecuniary condition of the patient, and the like, than upon the character and course of the disease.

ELECTRO-THERAPEUTICS.

SPECIAL PART.

PART V.

SPECIAL ELECTRO-THERAPEUTICS.

INTRODUCTION.

WE now come to the consideration of the action of electricity in individual forms of disease, the indications for the use of this remedy, and of the methods suitable in various diseases—i.e., to special electro-therapeutics.

In my previous lectures I explained that we had determined not a few points of departure from which we might expect various and even manifold curative effects from the use of electricity; but I was compelled to add that we are still restricted more or less to an empirical standpoint—that electro-therapeutics is still founded mainly on experience.

We must therefore carefully examine electro-therapeutical experiences, in order to determine whether they justify the assumption of curative effects; whether they can be subjected successfully to the inductive method of investigation, and can therefore be employed as the basis for the determination of therapeutic indications.

This means nothing more nor less than a critical sifting of my personal experiences, as well as of those accumulated in literature—a task which can with difficulty be carried out. Apart from the prejudices which most specialists entertain in favor of their own methods, of the more or less unintentional self-deceptions to which they are liable, we have to deal in these cases with forms of disease in which even the most conscientious and skeptical observer may fall a victim to the grossest error. In nervous diseases, especially in the numerous functional neuroses, remarkable improvement and recovery occur, apparently spontaneously, with such frequency, the psychical element and many other factors play such a great part, that the “post hoc ergo propter hoc” very often leads to false conclusions. In other cases, again, we have to deal with such tedious, morbid processes, that the possibility of spontaneous remissions and improvement will readily cloud our judgment with regard to the therapeutic result. Or other

simultaneous effects cannot be excluded ; the favorable results of other methods of treatment or after-effects of other cures (baths, etc.) may be falsely attributed to electricity.

If, in the face of such difficulties, the man of large experience does not entirely lose the hope of "rising from this sea of error," this is due to the fact that so much that is hopeful and stimulating is manifested in a varied experience, so much proof of the benign effects of electricity, that a never-ceasing stimulus to further labor and investigation in this difficult field is developed.

But for scientific demonstration, for the gradual formation of the foundations of scientific electro-therapeutics, an extremely careful selection of cases must be made. Those alone may be chosen which are based on certain and accurate observation, and in which, from the rapidity and magnitude of the results, from the exclusive application of electricity, and all the attendant circumstances, it is rendered as undoubted as possible that the therapeutic result is due solely to electricity and not to chance or other circumstances.

A second important object is the determination of the methods according to which the electrical treatment may be best carried out in individual cases. As you have learned, this cannot be done *a priori* upon the basis of our knowledge of the various physiological actions of the current, although these must serve as guides in our investigations, but is only possible upon the basis of a large and critically sifted experience. There can be no doubt that exact and scientific methods alone will lead to the goal. Above all, they must be based upon clear physical conceptions ; then they may be guided by our physiological knowledge of the most important actions of the current. Experience, however, must constitute the final and decisive criterion.

1. DISEASES OF THE BRAIN, INCLUDING THE PSYCHOSES.

LECTURE XV.

Introductory Remarks—Physiological, Experimental, and Theoretical Basis of Electro-therapeutics of the Brain—Therapeutical Facts—Collection of a Series of Individual Observations—Conclusions therefrom—Negative or Partial Curative Effects—The Forms of Disease in which Electro-therapeutic Success may, and those in which it may not, be expected.

For a long time certain prejudices prevented the direct application of electrical currents to the skull in various cerebral diseases. The occasional reports of the favorable therapeutic effects of such a procedure were received with decided mistrust. It was maintained by eminent authorities that the current could not be conveyed through the bones of the skull into the brain; while, on the other hand, others described in lively colors the dangers of such an application to the head, especially of the galvanic current. After my investigations had shown that the brain could be readily reached, even by mild faradic and galvanic currents, it was also gradually discovered that the application of electrical currents to the skull does not present any special dangers. Numerous experiments upon the healthy and sick, especially the often-practised examination and treatment of the auditory apparatus with very strong galvanic currents, have long since proved the contrary. The application of electrical currents to the head is very well tolerated, without exception, by healthy individuals; a certain amount of caution is necessary when the brain is diseased, but the stories of serious disturbances of the brain, apoplexy, amaurosis, etc., in consequence of faradization or galvanization of the head, have received no authentic corroboration.

The attempt could therefore be made, with a certain amount of confidence, to make cerebral diseases the subject of electrical treatment; but the question first arose whether any justification existed for attempting to treat diseases of the brain by the application of the electrical current and for expecting definite curative effects therefrom.

A more careful consideration shows, indeed, that various data are fur-

nished which, in a series of cases, lead to the hope of a favorable influence of electricity upon the diseased brain.

The simple fact that electrical currents really act upon the brain, that they produce vertigo, a feeling of dulness and nausea, that they act favorably upon sleep, etc., is indeed a very meagre foundation for therapeutical application. But at all events, we may therefore conclude that stimulating and modifying effects upon the cerebral substance are possible, that perhaps changes may be produced in the molecular or finer nutritive relations of the organ, and the outlook is thus presented of securing a favorable influence in morbid functional disturbances of the brain, in conditions of exhaustion, and perhaps in morbid irritations, sleeplessness, etc.

More important data are furnished by the previously mentioned statements with regard to electro-physiological action upon the cerebral vessels, the most important being their direct change (contraction and dilatation), as was experimentally proven by Loewenfeld. This at least opens up a more distinct possibility of accelerating or retarding the circulation in the skull and brain by means of electrical currents, of modifying the nutritive conditions, perhaps producing an alterative action upon pathological processes, of antagonizing hyperæmias and anæmias (primary as well as secondary) with their sequences. According to Loewenfeld's experiments, this would be possible in a *direct* manner; the physiological foundation for the indirect vasomotor influence of the cervical sympathetic and spinal cord upon the brain is less positively established.

Very few data are as yet available with regard to a more remote, indirect influence upon the cerebral circulation by means of reflexes from the integument; but the recent experiments of Rumpf and the therapeutic experiences reported by him, at least open up the possibility of securing favorable results in this manner; perhaps many favorable effects of peripheral electrical treatment upon cerebral affections can be explained in this way.

Even more obscure are the probably molecular, dynamical effects upon various cerebral functions from stimulation of sensory nerves. I do not now refer to the metalloscopic experiments, but to those of Vulpian, who, by means of local, circumscribed faradization of certain portions of the integument of the forearm, caused the disappearance of cerebral hemianæsthesias, which were probably produced in part by anatomical changes in the brain.

Much greater hopes are aroused by the catalytic effects of electrical currents, though these have only been determined with certainty in other parts of the body. The possibility of a direct action upon the brain and its parts being taken for granted, we are justified in assuming that these effects will not fail us in certain morbid processes within this organ, and it is therefore very probable that by means of electrical currents we can facilitate the absorption of hemorrhagic extravasations, relieve œdema and

collateral fluxions, improve the nutrition of parts, relieve, or at least moderate, chronic inflammatory, sclerotic, degenerative, and similar conditions.

I will now give a selected number of observations of this character :

1. *Observation by Neftel. Cerebral neurasthenia.*—A busy physician, aged forty-two, sick in consequence of over-work ; suffers from loss of physical and mental energy. Ability to work greatly diminished ; suffers from insomnia, a dull feeling in the head ; melancholic depression ; loss of desire and inability to work or read ; readily gets tired ; general weakness, feeling of heaviness in the back. Examination gave negative results, with the exception of some albumen in the urine without any morphological constituents. Galvanic treatment : Ca on the back of the neck, An stable and slowly labile over the eyelids, forehead, temples, and auriculo-maxillary fossæ on both sides ; then the same procedure with reversed position of the electrodes, and finally galvanization of the cervical sympathetic. Great relief after the first sitting, better sleep ; progressive improvement, finally recovery ; the albumen disappeared.

2. *Personal observation. Emotional neurosis ; hemiparesis of the right side.*—A merchant, aged forty-six, had a severe emotional disturbance (in consequence of being insulted) ten weeks before ; immediately afterward suffered from epigastric pressure, nausea, loss of appetite ; then vertigo, staggering walk ; later, gradually increasing weakness and tremor of the right hand, so that he could no longer write ; then a general feeling of weakness and being tired. Tendency to cry, depression, restlessness ; often has poor sleep. Memory is impaired, his thoughts often fail him in speaking. Examination shows slight paresis of the right facial nerve. The tongue, palate, mastication, and deglutition normal, also movements of the eyes and pupils. The right arm is decidedly weaker than the left ; marked tremor in stretching out the hand, the movements of which are somewhat awkward and weak (dynamometer, right hand 26° ; left hand 51°). Sensibility of the right upper extremity normal, the tendon reflexes somewhat increased. Motion and sensation of the right lower extremity normal ; the tendon and plantar reflexes slightly increased. Galvanic treatment ; 6 elements Stoehrer from the neck to the forehead ; 8 elements to the cervical sympathetic ; 18 elements Ca labile through the nerves and muscles of the right arm ; daily sittings.

June 26, 1879.—Before the first sitting, dynamometer, right 26°, left 51° ; after the first sitting, dynamometer, right 39°, left 44°. Better general condition and sleep afterward.

June 29th.—Changeable condition ; improvement on the whole. Before the galvanic treatment, dynamometer, right 32°, left 43° ; after the galvanic treatment, dynamometer, right 42°, left 41°.

July 5th.—Headache, vertigo, sleep improved. Before the galvanic treatment, dynamometer, right 40°, left 41° ; after the galvanic treatment, dynamometer, right 40°, left 43°.

July 12th.—Patient feels decidedly better with regard to the head and speech ; sleeps much better. Still complains of pain in the arm, which is much better, but not perfectly useful ; the slight difference in the face still continues. Stopped treatment.

3. *Personal observation. Insomnia ; mental depression.*—A widow, aged forty-one years, very depressed for about two months in consequence of emotional disturbance, with marked præcordial anxiety and almost com-

plete insomnia with very restless thoughts, restlessness of the limbs, etc. Moderate anemia. Appetite and digestion good. Chloral and morphia are not tolerated. Ordered tea and electrical treatment at night.

January 21st.—Faradization of the head with the hand.

January 22d.—No improvement; great terror; faradization of the head and also from the neck to the epigastrium.

January 23d.—Slept one hour and a half; terror much diminished.

January 24th.—Has not slept (on account of abdominal pain and diarrhœa).

January 25th.—Slept two hours; abdomen normal.

January 26th.—Has not slept (made a visit in the afternoon).

January 27th.—Has not slept; terror has disappeared. Galvanic treatment now begun: 4 elements, Stoehrer, from the forehead (An) to the back of the neck, stabile, for a minute and a half; 6 elements from the neck to the epigastrium, stabile, for a minute and a half.

January 28th.—Two hours sleep: terror has permanently disappeared.

January 29th.—Two hours and a half sleep; similar treatment.

January 30th and 31st.—Has not slept (menses about to begin!) but disposition good.

February 1st.—Three hours sleep.

February 2d.—Slept more than five hours; feels well. Beginning of the menses, during which she did not sleep for two nights; migraine; slight feeling of terror. No galvanic treatment.

February 5th.—Slept the whole night (seven to eight hours); has not had such a good night in months. Galvanic treatment.

February 6th.—Five to six hours sleep. Terror entirely disappeared.

February 7th.—Seven and a half hours sleep without interruption. No headache or terror; feels perfectly well. Leaves to-day. A later communication shows that the improvement has continued; sleeps four to five hours every night.

4. *Observation by Rumpf. Hyperæmia of the brain (?) (cerebral neurasthenia).*—A merchant, aged forty-seven years. No neuropathic tendency, formerly always healthy. In consequence of great exertion and excitement, first had unpleasant sense of pressure in the head, then readily flushing of the face and a feeling of congestion of the head. Increasing heaviness and dulness of the head, occasionally severe headache; annoying sensation of vertigo, especially in raising and lowering the head; ringing in the ears; diminished capacity for work; condition of excitement, even upon slight cause; very poor sleep. Spinal functions normal. Objectively everything normal. Bromide of potassium unsuccessful. Treatment: vigorous faradic brush over the back, chest, and upper extremities; this was followed by desire to sleep, head clearer. All symptoms disappeared after a second application.

5. *Personal observation. Right hemiplegia (from cerebral hemorrhage?).*—A carpenter, aged twenty-five years. February 10, 1872 (at a ball), sudden occurrence of hemiplegia, without loss of consciousness and aphasia, but with indistinct speech (anarthria). Complete paralysis of the right side, also the face; formication, but sensation retained. Gradual improvement up to present time; condition entirely healthy heretofore. Condition on April 8, 1872: right hemiplegia, paresis of the lower branches of the facial nerve, the tongue deflected readily to the right; uvula straight, velum palati normal. Forearm slightly movable, hand and fingers not at all; slight mobility at the shoulder-joint. Slight contracture of the

flexors of the arm. Lower extremity parietic and stiff, but patient can walk around. Sensibility normal; some feeling of numbness in the tips of the fingers. Pupils and ocular movements normal. No aphasia. Heart entirely normal.

Galvanic treatment: Longitudinally through the left half of the skull, stable, and transversely from the left forehead to the right brachial plexus; then the *Ca labile* through the nerves of the right arm. On the following day the patient states there is distinct improvement. Careful observation (April 9th) shows, before the galvanic treatment, absolute immobility of the fingers; the hand can only be raised to within an inch and a half of the nose and the hair on the temples. After the treatment (of the head alone), patient raises the hand readily to the nose, can flex the fingers slightly, the movements of the forearm are somewhat freer.

April 11th.—After each sitting the patient notices considerable improvement, and also in the leg, which has hitherto not been examined or treated.

April 15th.—Continued improvement; the movements of the arm are freer, flexion of the fingers is possible to a slight degree; the patient readily grasps the head and nose; the leg especially (which was never treated) is more vigorous after each sitting.

August 1, 1872.—The patient is discharged to-day very much improved. Walks freely and easily; mobility of the arm much better; also quite good in the extensors; no more contracture. Writing still impossible on account of deficient pronation. Since the end of September, the patient works a little at his trade.

6. *Observation by Brenner. Cerebral hemiplegia; sudden considerable improvement of the paralysis.*—A merchant, aged thirty-eight years; acquired syphilis in 1863; repeated relapses, irregular treatment. At the end of a year and a half the patient awoke one morning with complete right hemiplegia, distortion of the face and disturbance of speech. At the end of four weeks, complete paralysis of the right upper and lower limbs, with very moderate contracture of the flexors; paresis of the lower part of the face, without anæsthesia. After the muscles of the arm had been stimulated about half a minute, the patient suddenly became able to move the arm, to lift it from the trunk and flex the forearm. The effect upon the leg was even more striking; after a few contractions through the crural and peroneal nerves had been secured, the patient arose and walked through the room without support, though the foot dragged. In the further course of treatment the paralysis improved somewhat, though not much, and permanent hemiparesis with contracture remained.

7. *Personal observation. Right hemiplegia; sudden improvement.*—An officer, aged fifty-three years; suddenly paralyzed three years ago without loss of consciousness. At first complete paralysis. The face is now well, the leg still weak, the patient only able to walk with a cane; arm almost completely paralyzed, with marked flexor contracture. Electrical excitability normal. Immediately after faradization of the nerves and muscles of the arm, the patient can move the fingers somewhat better; likewise during the passage of a galvanic current transversely or longitudinally through the head. After this first (explorative) sitting, decided improvement had occurred; the patient feels freer and stronger, rising from a chair is effected more readily; he walks without a cane. The arm is not improved. Prolonged electrical treatment did not add much to the improvement thus effected at the outset.

8. *Observation by Neftel. Right hemiplegia and aphasia (from embol*

ism?).—A man, aged thirty-eight years. February 23, 1877, a severe apoplectic attack, followed by right hemiplegia and aphasia. Rapid improvement; persistent paresis of the lower limb, still more of the upper limb. Right-sided disturbance of sight and hearing; headache, melancholic depression; general weakness, sleeplessness; systolic murmurs at the apex of the heart. Paresis of the rectus internus of the right eye; nasal hemiopia of the right eye. Galvanic treatment (beginning March 19, 1877): 1. Ca in the neck, An stable and slowly labile upon the eyelids, forehead, temples and both auriculo-maxillary fossæ (4 to 7 Siemens' elements). 2. The same procedure with reversed electrodes. 3. Galvanization of the cervical sympathetic (Ca on the ganglion). Immediate improvement; head freer, sleep better; insufficiency of the rectus internus disappears, also the defect in the field of vision; the paresis of the limbs also improves (they were only treated twice, more for diagnostic purposes). Interruption of treatment on March 29th (eleven sittings). After a few weeks, a relapse, especially headache, vertigo, insomnia, pains in the right arm. May 29th renewed treatment (same plan); considerable improvement after eight sittings.

9. *Observation by Moritz Meyer. Hemiplegia, probably from hemorrhage.*—A merchant, aged twenty-six years, feeble, suffering from palpitation of the heart, and hypertrophy of the left ventricle without valvular disease; vertigo, followed shortly by unconsciousness, convulsions, and complete motor and sensory hemiplegia of the left side, paralysis of the bladder. Very gradual improvement. Two years later: left arm can with difficulty be raised to an angle of seventy degrees, is emaciated, cold, partly anæsthetic; moderate flexor contracture; head dull; bladder in tolerable condition. Treatment: in the beginning merely galvanization of cervical sympathetic (An to the left upper ganglion). Results very satisfactory; after twelve sittings the arm can be raised completely and extended, sensibility has improved; the leg is dragged less; head freer. Descending neuro-muscular current was then employed: after fifteen sittings the mobility of the hand and fingers was considerably improved; temperature of the arm approximately normal; sensibility not completely restored.

10. *Observation by Vulpian. Monoplegia of the right arm with complete anæsthesia (probably from a hemorrhage).*—A laborer, aged eighteen years; apoplectic attack; unconsciousness; upon restoration of consciousness, the right upper limb was found completely paralyzed; with the exception of a rapidly disappearing aphasia, the paralysis was exclusively confined to the right arm; in addition to the complete paralysis, there was also complete anæsthesia of the limb. Various methods of treatment (nitrate of silver, chloride of sodium and gold, faradization and galvanization of the paralyzed arm) produced very little improvement in mobility and sensibility. After the lapse of five months the patient was subjected to cutaneous faradization (active faradic brush to a very limited portion of the right forearm). Rapid improvement of motion and sensation occurs. Sensation improves daily from above downward; motion in such a manner that, at the end of twenty days, the dynamometer shows right 8°, left 57°. On one of the following days, dynamometer on the right side, before faradization 10°, after faradization 17°. At the end of five weeks, sensation is restored to the tips of the fingers, all movements of the arm executed without any special effort. At the end of two months: dynamometer, right hand 35°, left hand 60°. The patient uses the right hand as well as the left, but the former is a little weaker.

11. *Observation by Althaus. Left hemiplegia (from hemorrhage?).*—A woman, aged fifty-three years, two months previously had an attack of apoplexy with left hemiplegia. She can now walk a little, but the arm is entirely powerless; arm and leg warmer than on the right side; flexor contracture, whose passive removal causes great pain. Increased faradic excitability. Application of galvanic current to the right temple, the superior sympathetic ganglion, and from the spine to the nerves of the limbs, with interruptions of the current. Noteworthy effect upon the muscular contracture; soon after the sitting the patient can extend the arm and open the hand; the gait is also improved, but the improvement continued only a few hours. But after treatment for six weeks (twelve sittings), the patient can walk quite well alone, and has recovered the use of the arm in great measure; contracture and pain have disappeared.

12. *Observation by Althaus. Monoplegia of the right arm (from embolism?).*—A merchant, aged fifty-two years, suddenly suffers from a feeling of faintness and vertigo, and at once loses completely the use of his right arm; no disturbance of consciousness or speech; leg and face unaffected. Two days later complete paralysis of the forearm and hand, and almost complete anæsthesia of the hand and fingers. Application of the galvanic current for one minute to the left hemisphere; the patient can then move the wrist and the fingers somewhat. Two days later the improvement was found to be persistent, but had not progressed; galvanization of the brain again caused slight improvement of the motion of the hand: the addition of peripheral galvanization of the radial and median nerves produced further and more marked improvement. A third galvanic sitting secured complete recovery.

13. *Observation by Rumpf. Right hemiparesis (anatomical diagnosis uncertain).*—A man, aged thirty-six years; sick for several years; pains in the back, right arm, and hip; paræsthesia and weakness of the entire right side; inability to work, poor memory, dull feeling in the head, insomnia, poor spirits. Objectively patient shows slight paresis of entire right side, including lower branches of facial nerve; slight ataxia of movements on right side; distinct analgesia over entire body; tendon-reflexes very marked on both sides. Upon the left parietal bone is a somewhat deep osseous cicatrix, due to previous injury. Galvanic treatment, continued for some time, useless. Treatment with the faradic brush (to the trunk and extremities) causes rapid improvement; the pain and paræsthesia disappear, sleep improves. At the end of six weeks, the only symptoms remaining are a slight change in the position of the mouth and slight analgesia; the paresis has disappeared.

14. *Personal observation. Tremor of the head, attacks of vertigo (incipient multiple sclerosis?).*—A shoemaker, aged forty-one years; previously healthy, never syphilitic. In March, 1877, sudden severe attack of vertigo, with subjective appearance of fire; then loss of consciousness for two days; afterward severe headache, pain in the back and legs. On every attempt at motion, marked tremor of the head occurs, but disappears during rest. During next few months, gradual diminution of the tremor so that the patient was again able to work. April, 1878, renewed violent vertigo, headache, pain in the legs, sticking pain and ringing in the left ear; no disturbance of consciousness, but return of the tremor in much greater severity. Improvement in the hospital; tolerable condition, also, during the following winter.

End of March, 1879, another attack of vertigo, with severe headache,

but without disturbance of consciousness ; pain and a sense of heaviness in the legs ; greatly increased tremor of the head, and now tremor of the arms ; difficulty of speech ; feebleness of memory ; diminished mental ability ; eyesight also said to be enfeebled. Condition on June 7, 1879 : nothing abnormal in quiet position ; on excitement or motion, very active tremor and shaking of the head. Eyes normal also ophthalmoscopically. Otological examination shows old tubal and middle-ear affection on the left side. Tongue, gums, mastication, and deglutition normal ; speech somewhat stuttering and uncertain. No noticeable disorder of the upper limbs, except slight unsteadiness of movement and slight twitchings on the left side ; no distinct tremor and no ataxia. In the lower limbs, more decided uncertainty of movements, but no distinct ataxia. Galvanic treatment : longitudinally and transversely through the head, also to the cervical sympathetic.

June 16th.—The tremor has diminished perceptibly during the last few days ; to-day no trace of former tremulous movements is left. The patient also feels much better subjectively. Headaches have disappeared entirely ; occasionally a sense of pressure in the head ; greater mental vigor ; sleep improved.

July 2, 1879.—Discharged as entirely cured. In October, 1879, no cerebral symptoms are present, and the tremor has ceased permanently.

15. *Observation by Moritz Meyer. Left hemiplegia after acute encephalitis.*—A boy, aged eight years, acquired, in 1865, a complete paralysis of the left half of the body, associated with unconsciousness and violent convulsions. May, 1866, improvement in the leg. January, 1867, the arm still entirely useless, cold, drawn toward the thorax, moderately contracted. Deltoid and radial distribution partially, ulnar distribution completely paralyzed. Electro-muscular contractility intact ; sensation not disturbed. Treatment : faradization of the paralyzed muscles ; decided improvement after thirteen sittings ; after forty-two sittings, mobility of arm and fingers almost normal.

16. *Personal observation. Paralysis of numerous bulbar nerves.*—A laborer, aged forty-eight years ; sick since June, 1871, with pains in the upper limbs, stiffness of the lips, violent headache, flashes of light, and occasional diplopia. Later, pain in neck ; the head feels heavy and sinks forward ; increasing difficulty in mastication and deglutition. In the autumn of 1871, severe pains in the legs, occasionally weakness in the legs and arms ; constant, severe vertigo ; tinnitus aurium. The speech grew feeble and hoarse ; the tongue felt heavy ; flow of saliva ; tendency to ptosis. Sleep poor, disturbed by pain and tinnitus aurium.

January 30, 1872.—Slight impairment of speech ; voice feeble. Pupils and ocular movements normal ; no ptosis. Hearing destroyed on left side, diminished on right ; constant tinnitus aurium on both sides. Muscles around mouth stiff and awkward ; inability to whistle. Tongue cannot be protruded well ; shows distinct fibrillary contractions. Velum palati and uvula look normal, but stimulated with difficulty. Pain in neck and back ; no abnormality of position or mobility of head. Deglutition impaired ; mastication very much impaired. Sensibility normal throughout. Severe shooting pains in right arm, the power of which is somewhat diminished ; legs readily tired. Galvanic hyperæsthesia of both acoustic nerves ; poly-
pus in left auditory canal.

Galvanic treatment, 8 elements, Stoehrer, transversely through the temples and mastoid processes ; 10 to 12 elements to the cervical

sympathetic. An stable upon each ear, the current being gradually increased and diminished. Considerable improvement in a few days.

February 3d.—Slight headache; legs stronger; tongue protruded better; patient can again whistle; deglutition and mastication decidedly better.

February 12th.—Continued improvement; head stills feels a little dull; limbs almost free from pain; deglutition, mastication, and whistling normal; tongue protruded with readiness. The further course favorable, with slight interruptions.

March 27th.—Patient discharged cured, with exception of aural symptoms (after fifty-two sittings).

17. *Personal observation. Bulbar symptom-complex (Erb).*—A man, aged fifty-six years; taken sick in February, 1868, with shooting pains in neck, slight headache; afterward weakness of neck muscles, so that the head could no longer be held erect. In the beginning of June, increasing paresis of muscles of mastication and weakness of upper eyelids; finally, some difficulty in the movements of the tongue and interference with deglutition; otherwise normal. End of June, 1878, peculiar position of head from paresis of neck muscles; bilateral ptosis; marked weakness of muscles of mastication, the mouth usually kept open. Mobility of tongue not noticeably disturbed; it presents fibrillary contractions. Atrophy of the muscles of the neck. Limbs normal. Galvanic hyperæsthesia of the left acoustic nerve.

Galvanic treatment, 10 elements, Stoehrer, transversely through the mastoid processes, stabile, and also to the cervical sympathetic; Ca labile through the spinal accessory nerves and the neck muscles; slow improvement. After sixty sittings, the patient is decidedly better; can hold the head better, deglutition normal, mastication much improved. Discharged from September 7th.

October 30th.—Iodide of potassium administered. Distinct improvement upon readmission; position of the head markedly better; ptosis slighter; mastication and deglutition normal, mouth no longer kept open. After twenty-three sittings more, patient was discharged December 7, 1868, as almost cured.

The cases reported above prove beyond a doubt that electrical currents may produce recovery in various cerebral diseases, even in cases in which other remedies have been employed for a longer or shorter period and have proved more or less useless; that, indeed, our *a priori* expectations have been realized in a series of cases.

But you must not expect that this will occur with any regularity; it cannot be denied that these scanty positive successes are opposed to a much larger number of cases in which negative results were obtained.

There is also an entire series of cases which cannot be regarded as strict proof of the curative effects of electricity, because the improvement occurs very slowly and gradually, not infrequently other remedies being also administered. Here the favorable effect of electricity is not excluded but cannot be strictly proven.

Not infrequently cases occur (as in Observations 6 and 7) in which a very rapid and striking improvement develops forthwith after the em-

ployment of electricity, but only progresses to a certain extent, then comes to a stand-still and cannot be furthered by continued treatment. Thus we find, for example in somewhat chronic apoplectic paralysis, a striking improvement in mobility occurs almost suddenly. After one or two sittings, movements return which seem to have disappeared entirely, the patients can suddenly walk better, use the hand better, and hope for complete recovery. But this hope is deceptive. After a short time a stand-still occurs, and the subsequent improvement is very slight. We may also find that the sensory disorders, paræsthesiæ, disturbances of special senses, aphasia, anarthria, etc., which are associated with the hemiplegia, very rapidly disappear, while motion does not improve to an equal degree. In such cases we remove only the secondary disturbances, caused by pressure upon the vicinage of an apoplectic focus, by circulatory disturbances, œdema, inflammatory conditions, etc.; perhaps, also, a certain part is played by secondary peripheral nutritive disturbances in the nerves and muscles. We may expect curative results from electrical treatment, with more or less certainty, in the following cases and categories of cerebral disease :

Especially in so-called functional disorders of the brain, in various cerebral neuroses, of whose anatomical origin we are as yet ignorant. Here the catalytic effects of the current, its effects upon the blood-vessels, and finer nutritive processes probably come chiefly into play; perhaps something is due to the stimulating and modifying action of the current; as in the various forms of cerebral neurasthenia, insomnia, headache, migraine, the milder forms of psychical disturbances, in various cerebral forms of spasm, chorea, epilepsy, the cerebral disturbances of hysteria, etc.

Furthermore, in disturbances of circulation in which the effects of electrical currents upon the blood-vessels of the brain, which have at least been rendered probable by Loewenfeld's investigations, may be utilized, as also the more problematical indirect vasomotor effects of galvanization of the sympathetic or reflex effects from the integument; thus in hyperæmia and anæmia of the brain and the various morbid conditions which, in part at least unjustly, have been attributed to them.

To these may be added hemorrhages into the cerebral substance and the foci of softening caused by thrombosis or embolism, in which restoration of the destroyed nervous elements cannot be looked for, but in which the catalytic and vasomotor actions of the current may have a very favorable influence upon the absorption of the extravasations, the furtherance of collateral circulation, the removal of secondary conditions and sequences (circulatory and inflammatory disorders), the stimulation of nutrition, and the restoration of the function of the nerve-elements which have not been entirely destroyed.

Finally, a favorable influence of the catalytic action of the current may be expected in various chronic, inflammatory, and degenerative processes

in the brain, in chronic meningitis and encephalitis, sclerotic processes, various forms of degeneration and atrophy of nerve-elements.

A favorable influence must be excluded in tumors of the brain, in far-advanced processes of gray degeneration and sclerosis, thickening of the meninges, etc. But even here electrical treatment may act favorably upon the secondary conditions and sequences of these affections, upon which a part of the symptoms depend.

LECTURE XVI.

Development of Electro-therapeutical Methods—Direct Treatment of the Brain : Catalytic and Vasomotor Effects and the Methods of Producing them—Stimulating and Modifying Effects—Technique of the Application of the Galvanic and Faradic Current in Cerebral Diseases—Indirect Treatment of the Brain : Galvanization of the Sympathetic—Reflex Effects from the Skin—Symptomatic Treatment—Electro-diagnosis in Cerebral Diseases—Electro-therapeutics of Individual Forms of Disease : Cerebral Neurasthenia ; Insomnia ; Hyperæmia ; Anæmia ; Hemorrhage ; Cerebral Softening ; Inflammation ; Degeneration ; Sclerosis, etc. ; Bulbar Diseases—Incurable Cerebral Affections.

REFLECTION shows that we must depend chiefly, in the diseases mentioned, upon the vasomotor and catalytic actions of electrical currents. The galvanic current, therefore, has a wider field in diseases of the brain than the faradic, though the effects of the latter cannot be entirely denied.

We may endeavor to influence these diseases in various ways—by the direct method, by the direct application of the current to the seat of disease ; in an indirect manner by vasomotor influence, chiefly by galvanization of the sympathetic ; or in a reflex manner, by peripheral irritation of centripetal paths. Finally, an effect produced by special treatment of the peripheral parts whose functions are disordered (nerves of sensation and special sense, motor nerves and muscles, etc.) cannot be excluded.

The special methods of application under these various conditions are still based upon a cautious empiricism.

We must, above all, discuss the direct influence upon the brain.

With regard to the catalytic actions, the nature of the individual pathological disturbances is almost as unknown as the corresponding effects of the current from which we expect a cure. There is an especial uncertainty with regard to the action of one or the other pole or one or the other direction of the current ; the therapeutic experiment is alone decisive.

With regard to the vasomotor effects, certain points of departure are furnished by Loewenfeld's experiments.

It must be remembered, however, that these were only made on rabbits, that their results cannot be transferred without question to human beings, and that they are not sufficiently constant and decisive to be regarded as definitive and certain ; above all, however, that it is often doubtful as to what condition it were better to secure in the pathological case under treatment. Who will venture, for example, to say with cer-

tainty that in a hemiplegia from cerebral hemorrhage or embolism it were better to secure an hyperæmia or anæmia of the affected half of the brain? So long as we are uncertain on this point, we will not be able, even with the aid of Loewenfeld's results, to pass beyond a cautious trial.

Taking these difficulties into consideration, we may choose the following methods of influencing the circulatory conditions in the skull and brain :

To secure a diffuse, equable action upon the entire brain, employ longitudinal conduction of the current with broad, large electrodes, varying the direction according to the desired effect: if you wish to increase the flow of blood to the brain and accelerate the circulation, apply the An to the neck, the Ca to the forehead; if the flow of blood is to be diminished, the An is applied to the forehead, the Ca to the neck.

Transverse conduction of the current (with a suitable choice of the points of application), so that the morbid process is situated in the line connecting the electrodes, is preferable for localized foci of disease. The choice of the pole depends upon the indication; if the circulation is to be accelerated and the vessels dilated, the An is applied to the diseased side; in the opposite event the Ca is applied to this side.

Nor have we advanced much beyond surmises with reference to the stimulating and modifying actions of electrical currents. For who can tell with certainty whether the brain is in a condition of irritation or inhibition or paralysis in the various neuroses, or whether the anelectrotonic and catelectrotonic action of the current also occurs in the brain?

We are therefore restricted essentially to this stand-point, viz., that we must endeavor to pass the current with sufficient strength and density through the entire brain or the focus of disease. In the first choice of the position of the poles and direction of the current, we must naturally be guided by the few positive facts based on theoretical considerations—as for the rest, the problem consists in developing the technique by a cautious collection of well-controlled observations.

The galvanic current is most frequently employed. As a rule, it is well to use large electrodes, as the strength of the current is thus increased without intensifying its density to too great an extent; recently I employ almost exclusively the large head electrodes (*vide* page 17).

The methods of application employed by me are the following :

a. In order to influence the entire brain, either longitudinally from the forehead to the neck, or obliquely from the forehead and temple of one side to the opposite side of the neck and occiput (successively on both sides), I have almost always employed the An anteriorly. Occasionally, in order to secure a more unipolar action upon the brain, I have applied a large electrode to the vertex, or passed it slowly from the forehead to the vertex, while the other electrode was applied to the neck, back, sternum, a hand or foot.

b. In order to influence a localized morbid process, I employ mainly

the longitudinal conduction from the forehead to the neck upon the affected side (the An on the forehead) ; then transverse conduction through the affected region of the skull. Recently I have employed oblique conduction in such a manner that the morbid process is situated, as far as possible, in the direct line between both electrodes ; the An is usually placed upon the side of the lesion.

When the morbid process is very circumscribed, especially when superficial (in the cortex, injuries to the skull, etc.), one pole should be applied as directly as possible to the affected spot, the other pole immediately opposite or in some remote part of the body.

The faradic current may be applied according to the same technique. When a very mild application is to be made, you may employ the so-called "electrical hand." Your own hand is then employed as an electrode (usually the An of the secondary current) by grasping the corresponding electrode with the other hand and thus allowing the current to pass through your own body ; the hand employed in the application should be well moistened ; the other electrode can be applied to any part of the patient's body.

The following general rules should be observed :

Always employ weak currents and begin with very feeble ones. Control the strength by the galvanometer (15 to 25° deflection of the needle after introduction of 150 CR), or at least govern its strength by the occurrence of flashes of light and vertigo. This is especially true of the galvanic current. Do not make rapid openings and closures, still less reversal of the current. It is well to remove the electrodes gradually by passing them along the hair of the scalp. Short sittings are indicated, half a minute to a minute and a half at each place, rarely longer.

In many cases it is advisable to make galvanic "trial sittings ;" you can then readily determine whether the applications will be tolerated.

Indirect treatment of cerebral affections may also be employed.

Galvanization of the sympathetic is the most important in this respect. In the event of a unilateral lesion the question arises whether the sympathetic should be treated on one side alone. We do not know with certainty that the sympathetic affects the circulation and nutrition of the corresponding side of the brain alone ; furthermore, it is probable that the so-called galvanization of the sympathetic also affects other parts, the base of the skull, pneumogastric, cervical cord (in which decussation is partly effected), which may be of importance. It is therefore better to treat both sympathetics in all cases.

The method of galvanizing the sympathetic has been previously described (page 111).

Another method of indirect treatment of the brain is by reflex action from the integument ; it should be tried when you desire a distinct action upon the cerebral circulation, and may also be useful in various functional

disturbances, insomnia, psychoses, etc., and finally in disturbances of the sensory paths of the brain (hemianæsthesia). You may employ either stimulation of large surfaces of the integument, or of very circumscribed, distinctly localized portions.

In the first event the faradic brush is vigorously applied for four to six minutes, to the back, chest, and upper limbs, perhaps also to the lower limbs, the strength of the current being sufficient to produce contraction when applied to the median nerve in the fold of the elbow.

In the other event, a daily application of the faradic brush is made for eight to ten minutes, with tolerably strong currents, to a very small part of the integument of the anæsthetic or paralyzed side. The upper limb (external surface of the forearm) is preferable, because it appears to exert a greater reflex influence on the brain than does the lower limb.

Finally, in very many cases we resort to symptomatic treatment, *i.e.*, a peripheral and direct treatment of the main disturbances of function (paralysis, contracture, anæsthesia, aphasia, disorders of special sense, etc.); this is done according to the methods which will be described in the subsequent lectures. A great many successes have been achieved in this manner, for which there are various explanations. In the first place we may assume reflex influences, which partly affect the vasomotor tracts and thus influence the lesion itself, partly the paralyzed motor paths and there exert an anti-paralytic action. It is also conceivable, as Brenner has pointed out, that various nutritive, molecular, or other disturbances are produced in the peripheral parts, either as the result of the brain lesion or from the prolonged forced rest and inactivity of the paralyzed parts.

We will now briefly consider the electro-diagnosis of cerebral diseases. It may be stated as a general principle that the *electrical irritability of the motor nerves and muscles usually remains entirely unchanged in cerebral diseases, especially in paralyses.*

To this rule there are a number of exceptions, though none of great practical importance.

Slight increase of electrical excitability is found not infrequently in cerebral, especially apoplectic paralyses, for a short time after their occurrence, and also, it is said, when these paralyses are associated with contracture. A similar condition is sometimes found in certain spasmodic affections which are possibly of cerebral origin, such as chorea minor; whether tetany is to be placed in this class is still doubtful.

Simple diminution of electrical excitability occurs sometimes in hemiplegias acquired during childhood (after encephalitis, hemorrhage, etc.), in which the growth of the bones and the nutrition of the muscles remain defective.

Degeneration reaction occurs when the cerebral nerves suffer a severe

lesion at the base of the skull, or when the nuclei of the motor nerves are diseased, or finally, in very rare cases, when a descending secondary degeneration of the pyramidal tract spreads to the anterior gray columns of the cord, and thus produces degenerative atrophy in the domain of spinal nerve-tracts. In the very common cerebral paralyses after hemorrhage or embolism the electrical irritability ordinarily remains unchanged, often for years, and even delicate methods of examination fail to show the slightest difference between the two sides.

I will now give a short description of the treatment of individual forms of disease.

Among the functional disorders of the brain, I will discuss very few in this lecture; the most important ones will be discussed in detail in subsequent lectures. Our attention will be directed mainly to cerebral neurasthenia the chief symptoms of which are: a sense of pressure in the head, dulness, insomnia, loss of desire and inability to work, hypochondriacal and depressed mood, vasomotor disturbances, the various pathological conditions of anxiety, dyspepsia, palpitation of the heart, etc.

In galvanic treatment, very feeble, stable currents should be passed longitudinally, transversely, and obliquely through the head; perhaps, according to Loewenfeld, the An should be applied anteriorly when evidences of congestion are present, the Ca anteriorly in anæmia. It is sometimes useful to apply the current in succession in both directions; this can only be determined by making trial in each individual case. A strictly polar method may also be resorted to, one electrode being placed upon the vertex and the anterior part of the head, the other upon the feet (one to five minutes), or central galvanization according to Beard's method (page 118) may be employed. Finally, galvanization of the sympathetic and cervical cord is decidedly useful in many cases.

The most important feature of faradic treatment consists of mild faradization of the head by means of the "faradic hand" or a large head electrode, either longitudinally through the head (An anteriorly) or a unipolar application to the head, the other electrode being placed upon the feet. This is a transition to general faradization (page 116) which is of marked benefit in many cases. Rumpf also appears to have secured excellent results in some of these forms of disease by means of the farado-cutaneous brush.

You should begin in these cases with feeble currents and short sittings; if well tolerated, more vigorous currents may be employed. The galvanic sittings should not last longer than one and a half to five minutes, the faradic from five to ten minutes, and from three to six times a week. The treatment must usually be continued for a long time.

Insomnia, which is so important a feature to many patients, may be

treated in the same manner; the same methods may be employed as were described above in the treatment of cerebral neurasthenia. The results are often surprising (*vide* Observation 3).

Among the grosser anatomical changes in the brain, the circulatory disturbances are occasionally the subject of electrical treatment. The statements of Loewenfeld may here serve as a guide: longitudinal conduction of the galvanic current through the head, the An on the forehead in hyperæmia, the Ca in this position in anæmia. You may also add suitable treatment of the cervical sympathetic and spinal cord. The circulation within the skull may also be affected by a moderate faradic current passed longitudinally through the head (Loewenfeld), or by a reflex action from the integument by means of the faradic brush.

Cerebral hemorrhage, however, is the most frequent and perhaps the most important object of electrical treatment in this category. The first question which arises is, At what time after the occurrence of the hemorrhage should treatment be begun? We will do well to disturb nature's process of healing as little as possible and to await its development and direction. In this disease, I begin electrical treatment about three or four weeks after the occurrence of paralysis; in very mild cases we may begin a little earlier, in severe ones somewhat later.

The galvanic current alone may be employed in the direct treatment of cerebral hemorrhages. The method of its application consists of longitudinal, transverse, and oblique conduction through the head in the manner previously described. It is customary to apply the An to the side of the lesion; the duration and frequency of the individual applications should be those ordinarily adopted. Bilateral galvanization of the sympathetic is then employed in the ordinary manner.

In old cases, especially when associated with contracture of the paralyzed parts, it is advisable to employ oblique conduction, because the entire motor paths as far as the pyramids are thus affected; applications may be made also to the spinal cord, as I shall describe later.

In addition, peripheral symptomatic treatment should scarcely ever be neglected. To relieve the paralysis resort to labile application of the Ca (An in the neck) and repeated cathodal closures, or to faradization of the paralyzed nerves and muscles. Anæsthesia may be combated by the same procedures or by the methods of Vulpian and Rumpf. To relieve the contractures, you may repeat the experiments of Remak, securing relaxation of the muscles by powerful stabile currents or repeated interruption of the current or by very vigorous faradic currents; or, according to Lange, vigorous faradization of the contracted muscles, then passive stretching, fixation of the limb upon a splint in forced extension, and finally mild faradization of the more markedly paralyzed antagonists (the extensors).

The results of electrical treatment in cerebral hemorrhage and its se-

quelæ are so variable that accurate statements cannot be made with regard to them ; at all events, a trial is justified in almost all cases.

Softening of the brain from thrombosis and embolism, anæmic necrosis with its usual results, from the apoplectic attack to hemiplegia with contractures, anæsthesia, aphasia, etc., should be treated in the same manner as hemorrhages—so much the more because we are often unable to make a positive differential diagnosis between the two forms of apoplectic hemiplegia.

The electro-therapeutic measures are, in general, similar in the other anatomical lesions of the brain, such as inflammation, degenerations, atrophy, sclerosis, hydrocephalus, etc.

In the more diffuse forms of disease (chronic meningitis, diffuse periencephalitis, multiple sclerosis, hydrocephalus, etc.) it is advisable to employ longitudinal or bilateral oblique conduction through the skull with very large electrodes (with varying direction of the current on account of the desired catalytic action) ; in addition, treatment of the sympathetic and the cervical spinal cord. You may also make trial of reflex influence from the integument, and also of general faradization and central galvanization.

In distinctly localized diseases the applications naturally must correspond to the site of the lesion.

You should not give up hope too readily in such cases. Unexpected improvement and recovery sometimes occur, even in severe organic diseases. I remember three cases in which severe organic lesions were undoubtedly present (with choked disk, amaurosis, violent headache, vomiting, partial paralysis and spasms, etc.), so that the diagnosis of tumor could be made almost with certainty, and in which, contrary to all expectation, persistent improvement and almost recovery occurred ; and another case of apparently hopeless, severe disease of the brain (and the meninges) with severe epileptic attacks, advanced dementia, general severe tremor, paresis of the limbs with muscular contractures and increased tendon reflexes, etc., in which a remarkable improvement in all respects was secured by a year's treatment (electrical and medicinal).

I will now make a few remarks with regard to bulbar diseases. The most frequent form, viz., progressive bulbar paralysis (progressive muscular atrophy in the domain of the motor nuclei of the medulla oblongata), must be regarded as incurable ; the cures reported by Benedikt refer to other forms of disease. But there are certain varieties of bulbar disease in which electricity often effects favorable, even brilliant results. I have published a number of cases of this kind (*vide* Observations 16 and 17), and some of Benedikt's observations belong to this category.

The method of treatment—the direct treatment by means of the galvanic current alone—consists of stabile, transverse conduction of the

current through the mastoid processes (with varying direction of the current, as the disease is usually bilateral), or in longitudinal conduction from the forehead to the neck, or finally, oblique conduction. This is supplemented by galvanization of the sympathetic and the cervical spinal cord (ascending or descending currents, stabile and labile, through the cervical vertebræ, from the upper dorsal vertebræ to the neck). In the majority of cases it is very useful to secure a series of movements of deglutition (10 to 20 at each sitting) in the manner previously described; furthermore, peripheral galvanization and faradization of the neuro-muscular tract specially involved in the paralysis and atrophy.

The treatment of these bulbar affections generally requires feeble currents, short sittings, and long continuance.

In really incurable cerebral diseases you will rarely produce amelioration by means of the electrical current, but you may always attempt, in the manner previously indicated, to alleviate individual symptoms, such as headache, insomnia, mental depression, or anæsthesia and paralysis, etc.

APPENDIX.

ELECTRO-THERAPEUTICS OF THE PSYCHOSES.

LECTURE XVII.

Introduction—Investigations of Arndt and their Results—Short Résumé of the Literature—Available Effects of the Electrical Current—Rules and Methods of Electrical Treatment of Individual Forms of Psychoses—Treatment of Individual Symptoms.

THE electrical current, with its various therapeutical effects, appears destined to unfold a favorable curative influence upon the psychoses, especially the initial forms or incipient stages, in which we have to deal mainly with functional disturbances or finer nutritive, molecular changes in the brain, or in which, with our present methods of examination, we can, at the most, demonstrate changes in the circulation. Even in those cases in which grosser anatomical lesions (chronic, inflammatory, and degenerative processes) constitute the basis of the psychosis, a favorable action of the electrical current cannot be absolutely excluded, if we may reason from analogy.

Arndt is the only observer who has busied himself systematically and in detail with this subject, and he has arrived at the following conclusions with regard to the chief indications :

“Only such psychical disorders as depend upon so-called functional disturbances, or on temporary anomalous nutritive processes, or on circulatory derangements, can be cured by electrical currents ; they may also be useful in deeper-seated organic changes, if we seek amelioration merely.”

“Electrical treatment is therefore specially adapted for fresh cases ; rather for the milder, vague forms than for those which are characterized by violent symptoms.”

“General and especially a marked psychical hyperæsthesia constitutes a contraindication to the employment of the electrical current.”

“The faradic current simply acts as a stimulating measure ; it acts successfully, especially in simple conditions of depression, whether they

have developed primarily or as the result of previous violent processes. It is employed almost exclusively as cutaneous irritation of various portions of the skin; occasionally as faradization of the phrenic nerves, in order to stimulate the circulation and oxidation of the blood."

"The galvanic current also possesses other effects (alterative, sedative, catalytic); its sedative and soporific action appears to be especially marked; it is therefore available in almost all other psychoses which are open to galvanic treatment. The method employed, however, is by no means immaterial, and must often be determined empirically. If marked conditions of irritation, especially in the domain of circulation and respiration, are present, the descending current should be employed; the ascending current is chiefly resorted to in affections which indicate paralysis of the vascular system. The descending current, *i.e.*, the polar action of the An, therefore appears mainly indicated in the early stages of the psychoses, the ascending current, *i.e.*, the polar action of the Ca, in the terminal stages, especially of the more severe affections."

"But the current should not be applied to the head in the insane, but rather to the spinal cord (and medulla oblongata), with its important vasomotor, circulatory, and respiratory centres, and perhaps to the peripheral nerves (if these present irritative conditions, neuralgia, etc.). Galvanization of the head is not absolutely excluded, but is confined to those cases in which we desire temporary stimulation or sedation." (In his later experiments Arndt resorted regularly to galvanization of the head.)

"Success usually follows only after long-continued treatment; the strength of the current must be sufficient and the duration of the application sufficiently prolonged (ten to thirty minutes)."

By means of peripheral faradization of the skin and muscles in various parts of the body Arndt cured several cases of conditions of simple depression and marked apathy, in part in a remarkably short period.

With the chief or exclusive application of the galvanic current to the cervical cord and the peripheral nerves, a few cases were cured which presented various psychological disturbances (conditions of depression and exaltation), but which were characterized in common by various somatic conditions of irritation, increased sensitiveness, abnormal sensations, pupillary changes, digestive disorders, constipation, and especially vasomotor disturbances. The stable action of the An was particularly useful in these cases.

In another series of cases which were favorably influenced Arndt also brought the head itself, in addition to the cervical cord, sympathetic, pneumogastric, etc., under the influence of one pole (usually the An), while the other was placed at a distance (small of the back, thighs, hands, feet). These were cases of varying character—conditions of exaltation and depression, feelings of severe fright, several cases of severe katatonia, hysterical psychoses, reflex psychoses, etc.; but almost all of which had

developed upon a neuropathic and psychopathic basis, and in great part showed symptoms of irritation and irritable weakness in the distribution of the vasomotor and circulatory nerves, the pneumogastrics, respiration, the splanchnic and the genital nerves. As a rule, the action of the An upon the central nervous system was the most favorable; but Arndt also observed some cases in which its action was injurious, while the Ca had the desired effect. The choice of the method must therefore be modified, according to the occurrence or non-occurrence of a successful result.

Franz Fischer saw a case of severe hypochondriacal melancholia, with vivid hallucinations of all the senses, relieved in a short time by galvanization (longitudinally and transversely through the head); this observer also had a very favorable result from general faradization in a case of melancholia, with forced ideas and severe vasomotor symptoms, which had lasted for years; great temporary relief followed the first sitting, became permanent after the fifteenth, and advanced to recovery.

Engelhorn also observed admirable results from the same method in two cases of epileptic and hysterical insanity.

In general paralysis of the insane very slight beneficial effects were produced and these lasted but a short time.

Careful consideration shows that the greatest weight must be attached to the catalytic action of the galvanic current in the treatment of insanity by electricity. Next in importance are undoubtedly the vasomotor effects of electrical currents, especially of the galvanic; it is a matter of experience that vasomotor disturbances play a predominant part in the development and symptomatology of many psychoses. It seems to me that much less can be expected from the modifying action of the current, and I must regard as premature the view of Arndt that all the effects of the galvanic current must be attributed to anelectrotonus or catelectrotonus of the central nervous system. We should be satisfied at present with facts, and should endeavor to multiply and sift these, instead of resorting to hypothetical explanations. Finally, that the stimulant action of electrical currents may be utilized in psychiatry is proven with regard to the peripheral irritation of the cutaneous and muscular nerves, from which a modifying action upon the functions and circulation of the central organs may be expected.

I have had too little experience in this wide and difficult field to be able to furnish definite rules for the electrical treatment of the psychoses; I must therefore restrict myself to brief hints upon the subject.

You should employ electricity mainly in recent and relatively mild cases, especially the more vague, not fully developed psychopathic conditions, conditions of morbid fears, with sleeplessness, etc. The most suit-

able method in such cases is simple longitudinal (or oblique) conduction through the head, and at the same time galvanization of the sympathetic, perhaps of the cervical cord.

If such cases are associated with profound anæmia, general debility, impaired digestion, etc., it is justifiable to try general faradization, perhaps alternating with the galvanic treatment.

In severe, fully developed cases, in profound melancholia, in stupor and allied conditions, katatonia, hysterical and reflex psychoses, etc., you may employ a sufficiently energetic unipolar action of the galvanic current upon the head, neck, sympathetic, etc., the indifferent pole being applied to the head and abdomen; the intensity and duration of the current should be gradually but cautiously increased. The choice of the active electrode will depend particularly upon the quality of the somatic (especially the vasomotor, circulatory, and respiratory) disturbances present and the direction—exaltation or depression—of the psychical anomalies; in marked irritative conditions use the An; on the other hand, the Ca should be employed in depressed and torpid conditions, in symptoms of vasomotor weakness and paralysis. But do not forget that everything depends upon actual experiment, and that sometimes that pole is effective which is opposed to your theoretical considerations.

If the methods described do not prove successful, others may be resorted to. In conditions of stupor and in simple depression the faradic current is also suitable in the form of electro-cutaneous irritation of various parts, or, better still, in the form of general faradization.

In periodic melancholy galvanization of the head should be employed during the intervals of the attacks, perhaps also the continuous application of a simple galvanic element to the head (page 120), in order to prolong the duration of the interval if possible. In dementia paralytica very little can be attained by electrical treatment.

In conditions of profound excitement, such as acute mania, etc., electrical treatment should not be employed. It is also contraindicated in general nervous hyperæsthesia, and especially in psychical hyperæsthesia, when the mere attempt at electrical treatment throws the patient into a state of great anxiety and excitement.

In many insane patients you may direct special attention to the treatment of individual symptoms of the psychosis. Thus, for example, insomnia, which may be treated according to the methods above described (page 152); furthermore, hallucinations, especially of hearing, the treatment of which will be described at a later period.

Morbid fears are sometimes relieved by faradization or galvanization of the epigastric and præcordial regions.

II. DISEASES OF THE SPINAL CORD.

LECTURE XVIII.

Introduction—Physiological and Theoretical Basis for the Electro-therapeutics of the Spinal Cord—Therapeutical Data; Selected Cases—Conclusions therefrom—Therapeutic Failures—Forms of Spinal Disease in which Electro-therapeutic Success may be Expected—Methods and Technique of Electro-therapeutics of the Spinal Cord—Direct Treatment: Action of the Poles and the Direction of the Current—Methods of Application in Circumscribed and Longitudinal Diseases—Indirect Treatment: From the Sympathetic; Combined Treatment of the Sympathetic—Reflex from the Integument—Diplegic Irritation—Treatment of Points of Pressure and Points Dououreux—Symptomatic Treatment.

In the electro-therapeutics of diseases of the spinal cord we stand upon a somewhat firmer basis than in that of cerebral diseases. The number of positive successful cases is so great that the electrical current has secured an assured and prominent place in the treatment of chronic diseases of the spinal cord. And the entire electrotherapeutics depends, in the main, upon clinical and therapeutical experience.

Our physiological data with regard to the effects of electricity upon the spinal cord are extremely scanty, as is evident from the remarks made in a previous lecture (page 54).

But our general knowledge of the action of electrical currents, numerous therapeutical experiences concerning the peripheral nerves and other parts of the body, justified us in the same manner as it did in diseases of the brain (Lecture XVI.) in expecting an entire series of definite curative effects upon the diseased cord, although we possess much fewer experimental data than we do with regard to the brain.

Thus, in not a few cases, we might expect from the catalytic action of the current a favorable influence upon minute and gross nutritive disturbances, upon the various forms of inflammation and their sequelæ, the chronic degenerative processes, the so-called functional diseases of the spinal cord and the like. No less available do the vasomotor actions of electrical currents appear to be in circulatory derangements and for the purpose of relieving nutritive disturbances, etc., and so much the more, since recent experiment vindicate with increasing certainty that the circulation of the organ may be affected indirectly (less by means of vaso-

motor paths and the sympathetic than in a reflex manner from the skin). Finally, the currents may exercise stimulating and modifying actions upon the cord in certain morbid conditions (particularly in functional disturbances, conditions of irritation or debility, certain forms of spasm, functional paralysis).

But all these *a priori* considerations were idle speculation so long as they were not confirmed by practical experience.

The following collection of cases (the number of which might have been much increased) affords proof of such confirmation.

18. *Observation by Hitzig. (Myelo-)Meningitis spinalis subacuta.*—A soldier, aged twenty-three years. March, 1865, fell from his horse; constant pain in the back thereafter. May, 1865, pleurisy and a gastric affection (ulcer?). From July, 1865, more serious complaints: pain in the back, ex-centric pains in the limbs, general hyperæsthesia of the integument; fornication and feeling of numbness in the legs; partial and general muscular twitchings; diminished motor power; incontinence of urine. Later, great uncertainty of movements, especially in the dark; can only walk when bent over, on account of pains in the back; poor sleep. Status, January, 1866: great feebleness of the movements; stands bent over; totters during closure of the eyes. Pupils normal. Sensibility markedly disturbed; diminution of tactile sensation, with marked hyperæsthesia; great tenderness of the spine on pressure. Previous treatment (nitrate of silver, iodine, counter-irritation) unavailing. Galvanic treatment with descending stable currents through the spine. After eight sittings, quiet sleep for seven hours, almost no spontaneous pains, feeling of relief in the legs. During further treatment it was shown that galvanization of the sympathetic acts especially favorably upon the general condition. Later, the crural nerves were treated with the descending current. After six weeks' treatment no more nervous symptoms demonstrable, beyond moderate pain on pressure over several intervertebral spaces.

The patient then had a very arduous service for nine months, and then, in consequence of over-exertion and exposure, had a relapse with very marked and severe symptoms, from which he was almost entirely relieved in the course of two or three months by similar galvanic treatment.

19. *Personal observation. Chronic spinal meningitis (?); congestion of the cord (?).*—A boy, aged fifteen years, in February, 1870, had "inflammation of the brain" (headache, dizziness, vomiting, long-continued unconsciousness). Since then a great deal of headache; not so well as formerly. Since August, 1870, considerable pain in the small of the back and in the left side; since the end of December, 1870, great weakness in the legs, with a feeling of fornication and coldness; upper extremities normal. Sleep disturbed; occasionally vertigo. Status, January 20, 1871: several lumbar vertebrae tender on pressure; movements of the lower limbs performed with sufficient vigor, but patient is easily tired; does not totter on closing the eyes. Sensibility normal; reflexes not increased. Sight poor, on account of bilateral leucoma. Hearing normal; some tinnitus aurium (bilateral simple hyperæsthesia of the acoustic nerves). Galvanic treatment: 12 elements Stoelher ascending from the back to the cervical sympathetic, 16 elements ascending through the spine, the Ca being moved slowly up and down.

February 12, 1871.—Remarkable improvement. Headache and tinnitus aurium have entirely disappeared; no pain in the back; no paræsthesia or weakness of the legs.

February 18.—Discharged cured. Abnormal acoustic reaction continues.

20. *Personal observation. Spinal concussion (meningeal apoplexy?)*.—A laborer, aged fifty-five years. Four weeks ago fell from a tree upon his feet and buttocks; was immediately paralyzed in the legs; violent diffuse pains in the legs and back. The legs remained paralyzed about a week, then motion gradually returned, so that he can now walk a little. Anæsthesia never present. Micturition normal. Pains gradually disappeared. Status: distinct weakness of the legs, slow gait, dragging of the feet, no ataxia. Can with difficulty stand upon his toes or upon one foot. Sensibility normal; cutaneous and tendon reflexes retained; no distinct atrophy; electrical excitability simply diminished; sphincters and upper extremities normal. Treatment: galvanization of the spine and legs. Striking result; after a few sittings the patient can walk well, and is discharged cured after twenty-two daily sittings.

21. *Observation by Lewin. Complete paraplegia (from acute myelitis?); recovery by the use of galvanism.* A woman, aged thirty-five years, not hysterical; sick about three weeks; fever, weakness, and numbness of both legs, slight shooting pains; at the end of a week, sudden complete paralysis of the lower limbs, violent lancinating pains, girdle feeling, paralysis of the sphincters. Reflexes normal; sensibility not markedly affected. Treatment with stable descending currents. After five days, pains disappeared; the left leg can be raised somewhat. The paralysis of the sphincters disappeared in two weeks. At the end of a month, the patient can raise both legs and stand a few minutes; the fever has ceased. At the end of seven weeks, the patient walks freely around the room, though with a somewhat dragging gait.

22. *Personal observation. Traumatic paraplegia.*—A soldier, aged twenty-three years, received a bullet-wound in the cervical vertebræ at the battle of Worth, August 6, 1870. Immediately afterward, complete paralysis and anæsthesia of the lower limbs, and as high up as the thorax; retention of urine, later incontinence, which disappeared at the end of four weeks. Motion and sensation gradually improved, especially in the left leg. Status on October 20, 1870: the spinous processes of the sixth and seventh cervical vertebræ tender on pressure; sensibility quite restored; movements can be effected with the left leg, but with little power and certainty; the right leg still very paretic; frequent clonic movements of the legs, especially the right (ankle-clonus). Bowels and bladder normal. Electrical excitability well preserved in the lower limbs. Galvanic treatment: stable currents through the spine, special attention being paid to the injured parts; then the An in the neck and Ca labile along the nerves of the legs. Improvement now progresses very rapidly; after the seventh sitting the patient can stand a little on the left leg, and move the right leg more freely. After the tenth sitting he can walk around his bed; after the twelfth he can stand securely and walks a few paces; after the sixteenth he walks to the place of treatment, being aided merely by a cane. After the fortieth sitting he walks very well with a cane, the right leg being still dragged a little.

23. *Observation by Seeligmueller. Myelopathy, tabes dorsalis(?)*.—A mason, aged forty-two years. Two years ago had a second attack of "par-

alysis," which still continues. Gait uncertain and tottering; walks with the aid of a cane; drags the left leg, weakness of the right arm; violent tottering upon closure of the eyes. Pain in neck and small of back; paræsthesia of hands and feet; cincture feeling; anæsthesia of hands and anæsthetic zone in neck from the spine of scapula to the vertex. Impotence; weakness of bladder; constipation. Galvanic treatment: 10 elements descending through the spine, ten minutes every day. Wonderful effect after the first sitting; pain less, sensibility improved; for the first time in a long period patient walks across the street without a cane. After the fifth sitting, the gait evidently improved, tired feeling disappeared; sleeps well; sensibility almost normal. After fourteen sittings patient discharged cured; after eighteen months improvement still continues.

24. *Observation by von Krafft-Ebing. Tabes dorsalis.*—A butcher, twenty-six years old. Sick for a year; paræsthesia of the legs, with weakness and increasing uncertainty of gait; lancinating, boring pains in the lower limbs; uncertainty in the dark in going up stairs and turning around, can only walk with the aid of a cane. Bladder and rectum normal. Patient presents marked ataxia of the lower limbs; gross power retained; can only walk for about five minutes with the aid of a cane. Totters violently when the eyes are closed; circumscribed anæsthesia, chiefly in the right calf and foot. Galvanic treatment: stable current along the spine a few minutes every day, with labile stimulation of the peroneal nerve. Distinct improvement after the fourth sitting. At the end of five weeks the treatment had to be discontinued; improvement very marked; sensory disturbances entirely disappeared, no tottering upon closure of the eyes; power and endurance of the legs have returned, the patient can walk one or two hours and follow his trade.

25. *Personal observation. Tabes dorsalis.*—A tailor, aged thirty-three years. Previously had chancre; for past eight years typical lancinating pains, irritable weakness of the genital organs, tremor of the legs; for past three years, weakness of the legs, uncertain and jerky gait; paræsthesiæ. Rapidly grew worse three or four months ago. Status: marked ataxia of the legs; cannot stand alone; gross strength somewhat diminished. Cutaneous sensibility of legs greatly lowered; marked slowness of conduction of pain, with persistence of the sensation. Muscular sensibility greatly diminished; falls upon closure of the eyes. Cutaneous reflexes absent. Weakness of the bladder; impotence. Upper limbs, brain, and cerebral nerves normal. Galvanic treatment: 12 elements ascending from spine to sympathetic with changing position of anode; 18 elements ascending through the spine daily, with changing position of cathode; on alternate days, descending Ca labile through the nerves of the legs (nitrate of silver at the same time). At the end of a week patient feels easier and has greater certainty of gait. At the end of a month gait further improved, the lancinating pains much slighter; in a month and a half he walks alone with the aid of a cane. At the end of two months he can walk alone up and down stairs, and sensibility has improved objectively. Improvement continues for three months, when treatment was interrupted. Recovery progressed for six months, but was by no means complete. Patient walks alone without a cane, rapidly but still ataxic; can stand with feet in apposition; slight sensory disturbances present. Tendon reflexes still absent.

26. *Personal observation. Beginning locomotor ataxia (?) ; atrophy of the optic nerves.*—A woman aged thirty-seven years. Gradually increasing im-

pairment of vision during the past few months ; shooting pains ; formication of the legs ; rapidly grows tired on standing and walking. Sphincters normal. Status, January, 1874 : marked amblyopia, color-blind to red, diminished field of vision ; ophthalmoscope shows atrophy of optic nerves. Legs weak, gait tottering, slight dragging of right foot ; stands readily on left foot, with difficulty on the right. No tottering upon closing the eyes. Local anæsthesia on dorsum of right foot and the toes, sensibility otherwise normal. Upper limbs, brain, etc., normal. Simple diminution of electrical excitability in the peroneal nerves. Galvanic treatment : 14 elements from the spine to the sympathetic on both sides ; 13 elements ascending stabile and labile through the vertebral column ; 8 elements stabile from the neck to the closed eyelids. Considerable improvement after eight sittings ; pains much less, sensibility distinctly improved, patient walks much more securely. Marked improvement after thirty sittings ; patient can walk up two flights of stairs without difficulty, walks more rapidly and securely ; pains and formication have disappeared ; no sensory disturbance demonstrable objectively ; eyesight somewhat better. After the forty-fifth sitting (June, 1874) continued improvement ; walks and goes up stairs quite well ; no pain or numbness in the legs. Sensibility objectively normal, eyesight slowly improving ; ophthalmoscopic appearances the same.

27. *Observation by M. Meyer. Locomotor ataxia ; treatment of painful points on the spine.*—A lithographer, aged forty one years. Suffers from ataxia, cannot walk or stand without help ; paresis of the bladder and rectum ; paræsthesia and poor power of localization in legs and soles of feet ; disturbed sensation in the ulnar nerves ; lancinating pains in the legs and pain on pressure upon the fourth to sixth dorsal vertebræ. Galvanic treatment of painful points with stabile An enabled patient, after four to five weeks, to walk for hours. Two years later, a relapse occurred in consequence of exposure ; favorable effect of similar treatment, though not so rapid or complete ; some symptoms remained, but patient recovered complete motor power.

28. *Observation by Drissen. Locomotor ataxia ; treatment of a painful point.*—A man, aged fifty-two years. Suffering for six years from lancinating pains ; increasing ataxia ; gait very uncertain, falls on closing eyes ; anæsthesia of soles of feet. Tenderness on pressure over the first lumbar vertebra. Treatment : application of An to this vertebra, the Ca on the right and left ilia alternately. After fifth sitting tottering on closure of eyes scarcely noticeable ; anæsthesia of soles of feet disappeared ; patient walks long distances without feeling tired ; considers himself well and discontinues treatment.

29. *Observation by Brenner. Tabes dorsalis ; treatment of painful points on the spine.*—A laborer, aged forty-two years. Marked tabes for past year ; had syphilis, diplopia, lancinating pains, weakness of bladder, etc., followed by distinct ataxia, analgesia, absence of tendon reflexes, etc. Circumference feeling well marked in two places, one around the thorax, the other around abdomen. Galvanic examination with the Ca reveals very painful spot from second to fifth dorsal vertebræ and another from first to third lumbar vertebræ. After treatment for two weeks with the stabile An, the upper painful spot disappeared and with it the girdle feeling around the thorax ; after three weeks' further treatment lower painful point is considerably improved. Great improvement in remaining symptoms. (Patient also treated peripherally with the faradic current.)

30 *Observation by M. Meyer. Affection of spinal cord (tabes?) ; treatment with the faradic brush.*—Professional man, aged fifty-four years ; suffering for many years from weakness of limbs, periodic violent headache, pains in back and limbs ; numbness of the legs and bladder trouble began quite suddenly. Patient cannot stand well nor walk without assistance ; totters on closing the eyes ; cincture feeling ; partial anæsthesia of limbs, incontinence of urine. Treatment : faradic brush to the limbs with a distinctly perceptible current. After twenty sittings, patient can again walk long distances, use the hands in writing ; pains much slighter. Improvement continued for several years.

31. *Observation by Rumpf. Tabes dorsalis ; treatment with the faradic brush.*—A laborer, aged forty years ; no syphilis. Had lancinating pains for eleven years, with increasing diminution of power ; a violent gastric affection (gastric crisis?) was followed by great weakness of legs, abnormal sensations in feet and hands, girdle feeling, weakness of bladder ; finally, patient could only walk a short distance with the aid of a cane. Examination showed ataxia of upper and lower limbs, with retained motor power ; analgesia of entire body, diminution of tactile and temperature sensation, absence of tendon reflexes. Robertson pupil not present.

Treatment with the faradic brush : An to the sternum, brush to the back and limbs, for ten minutes every other day. At the end of a month, marked improvement in every respect, merely uncertainty in walking and tired feeling present. Faradic brush now alternated with galvanization of the spine, and five weeks later, patient discharged as well and able to work. Tendon and plantar reflexes still absent. At the end of a year improvement had continued.

32. *Personal observation. Spastic spinal paralysis (chronic dorsal myelitis?)*.—A woman, aged thirty years. Sick for five years ; weakness of the legs, with feeling of numbness and coldness ; gradually growing worse ; lately weakness of arms ; complete inability to stand and walk for past six months. Sphincters normal. Status : lower limbs very paretic, legs stiff ; on passive motion, very violent muscular contractures ; increased tendon reflexes (ankle-clonus). Sensibility scarcely disturbed ; cutaneous reflexes somewhat increased. Galvanic treatment of spine, including the sympathetic : surprising result ; marked improvement at end of five weeks ; legs much stronger, muscular spasms almost disappeared. Gait still awkward and stiff. Two months later motion much better, though not entirely normal ; patient still feels very weak, but can walk alone and go up the stairs. Slight muscular spasms and foot clonus still present. Patient discharged.

33. *Personal observation. Subacute anterior polio-myelitis.*—A man, aged forty-seven years. Tired feeling in legs for a long time ; taken sick in the beginning of October, 1878, with slight fever and feeling of heaviness and pains in lower limbs ; next day, great weakness, so that he was compelled to walk very slowly ; the following day he fell while walking, and in a week had complete paralysis of the legs, which only lasted a week, when a few movements gradually returned. No paresthesia or disturbance of sensibility ; bladder normal. Slight numbness in the hands and pain in the arms. Status at end of November 1878 : head and upper extremities normal ; slight depression of first intercostal space. Lower extremities : marked paresis in distribution of both crural nerves ; adductors paretic, also muscles in distribution of tibialis ; sensibility normal. Cutaneous reflexes retained ; tendon reflexes absent. The

paretic muscles more or less atrophied and very tender on pressure. Complete or partial DeR in all the muscles of the lower limbs. Galvanic treatment: 20 elements ascending and descending through the spine, especially over the lumbar enlargement; 24 to 26 elements Ca labile with change of polarity in the nerves and muscles of the legs. At the end of ten days patient walks around the room, feels stronger; the muscles are firmer and not so tender on pressure. Treatment continued, with intermission of a month, until February 6, 1879, when patient is discharged almost cured. Motor power excellent; De R only noticeable in distribution of peroneals; tendon reflexes still absent. Later, complete recovery.

34. *Personal observation. Chronic anterior poliomyelitis.*—An engineer, aged thirty-six years. Taken sick in February, 1877, with pains in the left arm, with diminution of power and atrophy. End of August, similar symptoms in left lower limb, then in the right; sphincters normal. Status (end of November, 1877): marked paresis of both legs, no ataxia or sensory disorder. Muscles very tender on pressure. Cutaneous reflexes feeble; tendon reflexes very vigorous. Trunk and right upper limb normal; left upper limb paretic and atrophied, sensibility normal. Partial De R present. Treatment: stabile galvanic current to spinal column. Distinct improvement after three sittings. The improvement continues, the De R gradually disappears, the muscles grow firmer and larger, and at the end of March, 1878, the patient may be regarded as almost cured.

35. *Personal observation. Progressive muscular atrophy.*—A brewer, aged twenty-six years. In winter of 1872-3, noticed slight weakness of right hand, with formication and occasional twitchings in small muscles of the hand; slight weakness of right shoulder; gradual depression of interosseous spaces of right hand. During last year and a half, similar condition of left hand. Recently, a certain weakness of the legs. Status (May 1, 1879): slight main en griffe on right side; marked atrophy of lower third of right forearm, with numerous fibrillary contractions; arm muscles feeble with fibrillary contractions. Left upper limb presents same appearances to less extent. Dynamometer, right 13°, left 19°. Sensation normal. Nothing abnormal in the legs; partial atrophy of some of dorsal muscles. Partial De R in the markedly atrophic muscles of the hand. Galvanic treatment: galvanization of the sympathetic; then An stabile to lumbar and cervical enlargements, followed by Ca in same position. Then An in neck, Ca labile through the nerves and muscles of upper limbs, especially in forearm and hand. June 7th (after twenty-six sittings), decided improvement; dynamometer, right 19°, left 33°; arms evidently stronger; can do more with his hands.

The fact should not be concealed that the electro-therapeutics of diseases of the spinal cord presents an extraordinarily large number of failures, indeed, much larger than the successes. This is to be expected, however, from the nature of the diseases in question.

The observations related above teach us that a favorable effect may be produced in simple functional disorders (neurasthenia, spinal irritation, concussion of the cord, perhaps also in acute ascending paralysis, etc.); also in circulatory disorders (hyperæmia, anæmia, increased transudation); finally, a favorable effect may be expected in all kinds of nutritive disturb-

ances and grosser anatomical changes (as in the sequelæ of acute meningitis and myelitis, in the chronic forms of these inflammations, in compression-myelitis, sclerosis, gray degeneration, atrophy, etc.).

We must confess, however, that there is an entire series of morbid processes in which we can hope for nothing from electro-therapeutics, for example, in old, far-advanced, chronic inflammatory and degenerative changes, in severe contusions and hemorrhages with their sequelæ, neoplasms, formation of cavities, etc.

Various methods are employed in order to attain therapeutic results. The spinal cord may be treated either directly or indirectly.

In the former method, the galvanic current is employed almost exclusively, since in the majority of cases we require its vasomotor and catalytic actions. Indeed, the faradic current has, for a long time, played a very subordinate part in the treatment of chronic diseases of the spinal cord.

The most important and indispensable condition is that the current be allowed to act upon the diseased part with sufficient strength, intensity, and duration.

The influence of the individual poles is still undecided ; they are probably equal with regard to the catalytic and vasomotor effects, while they vary with regard to the stimulating and especially the modifying effects. The choice of the poles must therefore be made according to general principles, but should nevertheless be controlled by therapeutical experiment in each individual case.

Still less do we know with regard to the influence of one or the other direction of the current, though most electro-therapeutists incline to the view that one or the other direction is preferable in the treatment of certain forms of disease. Thus, I prefer the ascending current in conditions of spinal debility, chronic degenerative processes, etc., and the descending current in irritative conditions ; frequently both directions may be employed alternately, in order to intensify the action upon the cord.

Taking these principles into consideration, the method of application in individual cases follows of itself ; the chief requisite is that the current pass through the cord with the greatest intensity possible, and you therefore need large electrodes, removed as far as possible from one another (*vide* Lecture IV., page 30). I generally employ my "large" electrodes, in very stout persons my "very large" ones. The application should be made with the entire surface of the electrode ; if the spinous processes are very prominent the electrodes should be applied to each side, the one to the right, the other to the left.

The special method of application depends upon the anatomical conditions of the individual case, and we may here make a distinction between longitudinal diseases of the spinal cord (funicular degenerations, etc.) and circumscribed diseases (transverse myelitis, infantile paralyzes, spinal apoplexy, etc.).

In the latter it is advisable to cover the entire site of the disease with one pole and to apply the other immediately opposite upon the anterior surface of the trunk, so that the morbid process is situated in the line of connection between the two electrodes. If you think that a purely transverse conduction of this kind is not sufficiently effective, place one electrode over the morbid process and the other as far as possible above or below it upon the spinal column; or under certain circumstances place the electrodes a little above and below the site of disease, as I have often done in compression-myelitis with prominent kyphosis.

In longitudinal diseases (tabes, sclerosis of the pyramidal track, multiple sclerosis, etc.) it is better to apply both electrodes to the spine, one in the neck, the other in the lumbar region. A stable action is usually desirable, but the points of application must be changed successively in order to bring the entire diseased part under the influence of the current of greatest density. This is done by fixing one pole and traversing the entire length of the spine with the other, and then reversing the process. This can also be done by fixing one pole upon the anterior surface of the trunk and successively traversing with the other pole the entire length of the spine.

At present the indications with regard to the choice of poles are very indefinite; the anode is generally preferred when symptoms of irritation predominate, in recent active morbid processes, in very irritable and sensitive individuals; the cathode, on the other hand, when symptoms of debility and paralysis predominate, in old, torpid morbid processes (gray degeneration, sclerosis, etc.). When a catalytic action is especially required, it is best to employ both poles in succession.

Great caution is requisite, in the beginning, with regard to the intensity of the current and the duration of the applications. Only weak currents should be employed and the duration of the individual applications should not, at first, exceed one to two minutes, so that the entire sitting will last four to eight minutes. If the current is well tolerated, you may gradually increase its intensity and duration.

In the indirect treatment of the spinal cord the chief consideration must be bestowed upon the so-called indirect catalysis of Remak, *i.e.*, the action upon those vasomotor (and trophic) nerve-paths which have a determining influence upon the circulation and nutrition of the organ. For this purpose, treatment of the cervical sympathetic has hitherto been resorted to, with what justice it is difficult to say. However, experience seems to teach that treatment of the sympathetic is not devoid of benefit in certain affections of the spinal cord; this is, perhaps, especially true when the process extends into the cervical portion, and the pupils, certain cerebral nerves, and the brain itself are affected. I have, therefore, often employed a method of application to the spinal cord which influences, at the same time, the cervical sympathetic; the Ca (medium electrode) is placed over

the upper cervical ganglion of one side, the "large" An upon the opposite side of the vertebral column, immediately adjacent to the spinous processes, at first stabile upon the lower cervical and upper dorsal vertebræ then gradually moving downward and remaining a little while at each place; this method is then repeated upon the other side, one to one and one-half minute sufficing for each side. I then usually apply the Ca stabile upon the spinal column, successively changing the point of application while the An is held upon the lower lumbar vertebræ (one to one and one-half minute).

Another method of indirectly affecting the spinal cord is by reflex irritation from the integument by stimulating the sensory nerves of the skin. This may be done either by means of "general faradization" or by the application of the faradic brush to a large part of the integument of the trunk and limbs.

Finally, the treatment of certain painful points should not be neglected. I have discussed this method sufficiently in the general part (Lecture XII., page 119). Whenever painful points (either upon pressure or examination with the Ca) are discovered, we should not fail to make them the starting-point of therapeutical experiments.

In addition, an entire series of symptoms of spinal diseases may be made the subject of electro-therapeutical measures. These symptoms include paræsthesiæ, anæsthesiæ, neuralgias, paralysis, spasms, contractures, weakness of the bladder and rectum, spermatorrhœa, impotence, etc. The special methods employed in combating these symptoms will be considered in subsequent lectures. However, this symptomatic treatment may only be regarded as an aid to the direct treatment of the spinal cord.

LECTURE XIX.

Treatment of Individual Forms of Spinal Disease—Electro-diagnostic Preliminary Remarks—1. Spinal Meningitis—2. Meningeal Apoplexy—3. Functional Diseases of the Cord ; Concussion, Spinal Irritation, Spinal Neurasthenia—4. Hemorrhages into the Spinal Cord : Severe Traumatic Lesions—5. Myelitis ; Multiple Sclerosis—6. Tabes Dorsalis ; Direct Galvanic Treatment ; Treatment of the Painful Points ; Farado-cutaneous Brush—7. Spastic Spinal Paralysis—8. Acute Anterior Poliomyelitis ; Electrical Examination ; Electrical Methods of Treatment—9. Subacute And Chronic Anterior Poliomyelitis—10. Progressive Muscular Atrophy ; Condition of the Electrical Irritability ; " Juvenile " Form ; Method of Treatment ; Amyotrophic Lateral Sclerosis—11. Acute Ascending Paralysis—12. Secondary Degenerations.

I WILL NOW give a brief sketch of the

TREATMENT OF INDIVIDUAL FORMS OF SPINAL DISEASE.

With regard to electro-diagnosis I will premise that all possible changes of electrical irritability may occur in diseases of the spinal cord. They depend almost entirely upon the implication of the gray matter in the lesion ; if the latter is affected and seriously injured, the De R, either partial or complete, will appear in the neuro-muscular tracts supplied by it. If the gray matter of the anterior columns is not affected, no qualitative changes will develop, at least no De R ; we may then observe various grades of simple diminution, more rarely an increase of electrical irritability. In such cases the diminution is caused chiefly by the forced inaction of the motor apparatus, in part by the direct influence of the disease. In isolated cases, qualitative anomalies of irritability have been observed in individual motor nerve-trunks (*vide* page 91).

1. *Spinal meningitis* only forms the subject of electro-therapeutics in its chronic or, at most, subacute forms. The symptomatology may vary greatly ; pain and stiffness in the back, paræsthesiæ and excentric pains in the limbs, symptoms of motor irritation and weakness, rarely true paralysis and atrophy, more or less diffused anæsthesia, weakness of the bladder, etc., may occur and are not infrequently subject to great variations. The electrical irritability presents no characteristic relation, but when the anterior roots are atrophied and degenerated, diminution of irritability and De R may occur.

The treatment depends, in the main, upon the production of catalytic

effects, and therefore requires stable currents, as far as possible through the entire extent of the cord ; both poles are applied to the spine, and both are moved successively from the neck to the loins. When irritative symptoms predominate, the descending current is allowed to act most vigorously, the Ca being placed as low as possible on the sacrum. This unipolar action is secured most effectually if the Ca is placed upon the anterior surface of the trunk. The current should possess moderate strength, at least in the beginning ; the sitting may last from four to ten minutes.

2. In *meningeal apoplexy* (sudden, apyrexial occurrence of meningeal irritative symptoms with rapidly developing paraplegic paresis or paralysis, which usually begins to disappear rapidly) decided benefit can be obtained in the stage of absorption and beginning convalescence by the application of the galvanic current. The application depends upon the site and probable extent of the hemorrhage ; stable action of the current, both poles alternately, is required ; in addition, peripheral treatment of the paralyzed, anæsthetic, or atrophic parts.

3. *Functional diseases of the cord* appear *a priori* to belong among the most favorable objects of electro-therapeutics, but not infrequently our expectations are sorely disappointed. In the majority of these cases electrical examination affords no noteworthy results.

In *concussion of the cord* you will, as a rule, only be called upon to treat its sequelæ, either milder functional disorders, weakness, etc., due to finer nutritive disturbances, or more serious and progressive functional disorders due to a slow myelo-meningitis (railway spine). In the latter event the treatment is the same as in other cases of this kind ; in the former event we seek in part a direct or indirect stimulation of the spinal functions, in part a direct or indirect influence upon the nutritive and circulatory conditions. You may therefore employ various methods of treatment ; galvanization of the spinal column with stable, not too strong currents, ascending and descending ; the most active pole to be chosen according to the chief symptoms ; in addition, perhaps symptomatic treatment of the principal peripheral disorders. Furthermore, faradization of the spinal column ; also general faradization, especially in general debility and poor nutrition, in delicate females, etc. ; finally, perhaps, cutaneous faradization, especially in the cases in which symptoms of sensory irritation and neuralgias occur, or in which distinct signs of hyperæmia or anæmia of the cord are present.

True *spinal irritation* is extremely rebellious to electrical treatment, but brilliant results are sometimes obtained. The treatment may be the same as in concussion, but should be employed with great caution and very feeble currents. In many cases it suffices to employ an ascending stable current through the spinal column from the small of the back to the neck, or in such a manner that the specially painful parts are situated

between the poles ; weak currents and short sittings are indicated. The anode may also be employed stable, with a weak current, upon the specially painful vertebræ (three to ten minutes) ; in some cases, however, the Ca produces better results. You may also try direct, moderately strong faradization of the spinal column ; also the farado-cutaneous brush, when irritative symptoms are prominent, perhaps the application of the faradic brush as a counter-irritant over the painful spinous processes ; in some cases, general faradization appears to have excellent results. Central galvanization may also, perhaps, be tried with benefit, especially when cerebral symptoms are present.

In *spinal neurasthenia*, the most frequent of all functional spinal diseases, with its predominant symptoms of debility and exhaustion in all possible districts of the spinal nervous system (motor weakness, paræsthesia, sexual exhaustion, etc.), various forms of electrical treatment may be applied ; two forms deserve special mention, viz., galvanization of the spine with ascending stable currents, perhaps associated with an application to the cervical sympathetic and general faradization, which is credited with excellent results in this very field. If these methods do not prove successful, you may resort to the treatment of painful points upon the spine, or the cutaneous brush, perhaps to central galvanization. In addition, peripheral treatment of the legs and genitals in suitable cases ; perhaps, also, of the cervical sympathetic and the head (insomnia, depression, etc.).

4. *Hemorrhages into the spinal cord* may be treated according to the same principles as cerebral hemorrhages. According to the site of the hemorrhage, the symptoms consist of paraplegia with anæsthesia, paralysis of the bladder, with or without atrophy of the muscles and De R. Electrical treatment can only be begun when the disease has passed into the chronic stage.

Much cannot be expected from galvanic treatment, but we may hope to restore tolerable function to those parts not entirely destroyed by the lesion. The site of the latter can usually be determined with readiness, and a large electrode should be applied directly over it, first the An then the Ca, while the indifferent electrode is applied either above or below upon the spine or upon the sternum ; stable current for several minutes. In addition, peripheral symptomatic treatment of anæsthesia, paralysis and atrophy, paralysis of the bladder, etc.

The same measures will serve in severe *traumatic lesions of the spinal cord* (incised or bullet wounds, compression from fracture or dislocation of the vertebræ, severe concussion, etc.) if the case has passed into a chronic stage of paraplegia. Though much cannot be expected in these cases I have often been of service to the patients by the restoration of function in individual muscles.

5. *Myelitis* in its numerous forms presents various indications in electro-therapeutics, chiefly in the subacute and chronic forms, since the ap-

plication of the current should be dispensed with in the fresh stages of an acute myelitis.

Apart from those forms which are restricted to the anterior gray columns and the funicular degenerations (systemic diseases, tabes, lateral sclerosis), the ordinary varieties of chronic myelitis (transverse myelitis, multiple sclerosis, central myelitis, compression-myelitis, general progressive myelitis, chronic myelo-meningitis, etc.) present but little chance of good effects from electrical treatment. But we meet occasionally with cases in which it is of very evident benefit and in which even complete recovery is secured. This I have observed repeatedly in transverse dorsal myelitis; compression-myelitis, when due to Pott's disease, also offers relatively favorable chances; even in multiple sclerosis I was sometimes forced to attribute intermissions, in part, to the favorable action of electrical treatment.

The condition of the electrical excitability varies greatly according to the character of the lesion. In a large majority of the cases it remains normal; in isolated cases I noticed distinct increase of the faradic and galvanic excitability of the nerves in the paraplegic limbs; more frequently there is slight quantitative diminution of irritability; not at all infrequently partial or complete De R was observed when the anterior gray horns of the cervical or lumbar enlargements were implicated.

The electrical current can only act in these forms of disease by means of its catalytic effects, and direct application of the galvanic current to the site of disease is therefore indicated. Various methods are suitable; in circumscribed foci of disease, the stable and successive application of both poles with a moderate strength of current and not too long duration (one to five minutes); in more diffuse or funicular affections, longitudinal conduction with successive change of the points of application, perhaps also an application to the cervical sympathetic. When painful points are present, the An is to be applied stable. In compression-myelitis with kyphosis, the electrodes should be placed above and below the latter. In addition, symptomatic treatment of the most important disturbances of function is indicated.

In *multiple sclerosis* applications must be made to the brain according to the methods previously indicated.

6. In *tabes dorsalis* the application of the electrical current constitutes one of the most important measures of treatment. The results obtained in this disease are not brilliant; recovery, or a condition bordering on recovery, occurs in but a very small percentage of cases, and in a large proportion our efforts are entirely useless.

A therapeutic trial alone can decide whether the prognosis will be favorable or unfavorable; but so much less can be expected from treatment the more advanced the progress of the disease. At present we can make a diagnosis in the earliest stages from a series of very important in-

itial symptoms (lancinating pains, paræsthesia, tired feeling in the legs, absence of tendon reflexes, reflex rigidity of the pupils, analgesia and slowness of conduction of pain, tottering on closure of the lids, paralysis of ocular muscles, weakness of the bladder and sexual power, etc.), so that most patients have a chance of the earliest possible treatment.

In many cases of tabes I have found the electrical excitability entirely normal. In a series of cases I noticed slight increase of the faradic and galvanic irritability of the peroneal nerves (especially at a relatively early stage); in another series, moderate diminution of irritability in these nerves. Qualitative changes of the law of contraction occur very rarely in the nerves (*vide* Lecture X., page 91).

The most important feature in treatment is the direct application of the galvanic current to the spinal cord. The methods employed by various authors differ very little from one another. I usually employ the method described above (page 169) of application to the spinal cord and the cervical sympathetic, and I have every reason to be satisfied with this plan. The application should last from three to five minutes; the strength of the current should be very carefully chosen; sittings daily, usually for a number of months.

With this central treatment you may associate peripheral galvanization of the nerves of the lower limbs (Ca labile, An on the lumbar spine); faradization is also praised by many patients.

Next comes the symptomatic peripheral treatment of the various phenomena of tabes (paralysis of ocular muscles, atrophy of the optic nerves, anæsthesia, etc.), according to the methods which will be described hereafter. The lancinating pains are sometimes relieved by various procedures, such as stabile application of the An to the spine at the point of origin of the affected nerves; stabile application of the Ca on the painful and hyperæsthetic portions of integument (the An upon the roots of the nerves); increasing faradic current to the same region, etc.

Two other methods merit a trial in suitable cases. One is the treatment of galvanic pressure or painful points by the stabile application of the An. At first the painful points and the girdling pains associated with them disappear and an improvement of all the other symptoms usually follows. Unfortunately, these painful points are extremely rare.

The other method is the application of the farado-cutaneous brush, which has been repeatedly recommended by Rumpf. This procedure consists of vigorous faradic brushing of the integument of the trunk and limbs for about ten minutes, either daily or every other day. Rumpf recommends this plan for those cases alone in which pains and paræsthesiæ still constitute the most prominent part of the symptomatology.

7. In *spastic spinal paralysis* when due, as pure cases probably are, to funicular degeneration of the pyramidal tracts, the same galvanic treatment is indicated as in *tabes dorsalis*.

The electrical irritability in this disease presents no anomalies, or, at most, a slight diminution of the faradic and galvanic excitability.

If you are in doubt with regard to the diagnosis and surmise that the symptoms may be due to a beginning dorsal myelitis or the beginning of a multiple sclerosis, or, as is not so very infrequent in children, an affection of the brain (chronic hydrocephalus), the electrical treatment suitable to these forms of disease should be instituted.

I have repeatedly obtained very favorable results in cases of spastic spinal paralysis.

8. All electro-therapeutists are agreed that *acute anterior poliomyelitis* (infantile spinal paralysis) is a suitable object for electrical treatment. This term refers to acutely developing forms of paralysis with rapid degenerative atrophy and De R, without sensory or bladder disturbance, etc., in which the paralysis reaches its acme at the onset and then recovers in part; the paralysis is due to an acute inflammatory process in the anterior horns of gray matter, affecting by preference the cervical and lumbar enlargements.

The conditions of electrical excitability in this disease are of no slight diagnostic and prognostic importance. The De R must be regarded as a constant phenomenon in this affection; as a rule it is complete, but in some muscles and nerves it is only partial.

A careful examination is attended generally with very great difficulty, at least in little children. There is certainly no more ungrateful object of electrical examination than these little crying and struggling patients, who dread such manipulation extremely on account of the retention of sensibility, and in whom the localization of the current and the recognition of the effects to be obtained are rendered still more difficult by the abundant panniculus adiposus. Not infrequently the patients come under observation at a late stage, when even the galvanic excitability has been lowered markedly, and the determination of the result is rendered more difficult in this manner. In the majority of cases, accordingly, we must confine ourselves to a superficial recognition of the De R, obtained by a few closures or changes of polarity of the galvanic current, and with a short faradic examination of the nerve-trunks. The slowness of the contractions and the predominance of An Cl C are particularly characteristic. In recent cases, however, in which exaggeration of galvanic excitability still persists, and in adults, the recognition of De R does not present the slightest difficulty.

As a rule, complete De R is found in the majority of neuro-muscular tracts; partial De R may be present in some of these tracts, but this does not occur very often. Whether De R may be entirely absent in certain mild cases (the so-called "temporary" forms of infantile paralysis) in all the affected groups of muscles, does not appear to me to be settled definitely, but it seems quite possible.

In those muscles which are partially restored, the phenomena of the De R disappear ; after the disease has lasted for a long time, the markedly atrophied muscles become almost absolutely inexcitable.

The indications and methods of application of the electrical current are very simple and precise ; we have to deal with sharply localized, small foci of inflammation and their residua, and with a degenerative atrophy of the peripheral motor-nerves and muscles, similar to that occurring in every severe traumatic paralysis. But experience has shown that the prognosis with regard to complete recovery is almost always bad. Only in the mild, temporary forms will rapid or complete recovery be secured ; in the ordinary severe forms we can, at the most, restore the function of the slightly affected muscles, the others can be improved to but a slight extent. In not a few cases, however, persistent treatment may serve to strengthen individual muscles, and thus perhaps be of great advantage to the patient.

The earlier the treatment is begun, the greater the chance of saving what is not yet irretrievably lost, and it should therefore be instituted as soon as the acute inflammatory stage has subsided.

The direct treatment of the morbid process is the most important ; the galvanic current should be employed with stabile action upon the cervical or lumbar enlargements, or on both. The site of disease is covered with a "large" electrode, the other being applied to the anterior surface of the trunk or other indifferent spot (first the An, then the Ca), for one or two minutes with a moderate strength of current (15° to 40° N. Def., 150 C R). If both enlargements are implicated, one pole is applied over each, and the current allowed to pass first in one, then in the other direction.

In addition, the paralyzed neuro-muscular tract should be galvanized peripherally with the Ca labile, the An being placed over the site of disease ; in the later stages, it will be necessary to employ cathodal closures and changes of polarity with a considerable strength of current.

Frequently it is only after protracted treatment that slight, slow, muscular contractions again make their appearance. The object of this form of treatment is to antagonize the degenerative atrophy and preserve the muscles until voluntary conduction is again possible. This object is often achieved very imperfectly, though sometimes in a surprising manner. You should, therefore, not be dismayed by the labor and time which must be expended upon the peripheral treatment.

The entire treatment must be continued for a very long time ; if begun very early, it should be kept up constantly from six months to a year. In older cases, it is sufficient to use galvanism about twice a year for two to three months at a time (forty to sixty sittings) and to employ other measures (baths, massage, gymnastics, etc.) during the intervals.

A certain amount of success has also been obtained from the use of the faradic current, applied peripherally to the paralyzed muscles. Reliable

authorities have even reported successful results from its application to muscles which exhibit complete De R.

This cannot be accounted for on the theory of a peripheral irritation of the trophic paths; it is more probable that a reflex influence is exerted upon the site of disease, the centripetal sensory paths being entirely intact.

9. *Subacute and chronic anterior poliomyelitis*, in its various forms, presents a much more favorable prognosis. This form of disease is characterized by a more or less rapid, and for a time, progressive atrophic paralysis, usually in a paraplegic form, without disturbance of sensation, the sphincters, or the cerebral nerves,—a flaccid paralysis with rapid degenerative atrophy of the muscles and partial or complete De R. Its course is usually favorable; it soon comes to a stand-still, and the paralysis not infrequently recovers completely. It is undoubtedly due to a nutritive (inflammatory?) disturbance of the anterior gray column, but which evidently does not possess the destructive character of acute anterior poliomyelitis.

Electrical examination in this disease reveals the presence of the De R in all possible stages of development. With the recovery of the disease, the electrical excitability slowly returns to the normal.

The electrical treatment consists of the application of the galvanic current to the spine according to the methods previously described.

As the enlargements are the usual site of the disease, these should be specially subjected to the action of both poles in succession, with stable currents of sufficient strength. In addition, peripheral treatment of the paralyzed and atrophied neuro-muscular tracts with the labile Ca, changes of polarity, etc., according to the circumstances of the case. The faradic current may usually be dispensed with in this disease, though it may be employed for peripheral irritation of the nerves and muscles in partial De R.

The results are generally satisfactory. I have repeatedly observed an immediate beneficial effect from the use of the current, and, as a rule, the improvement is very distinct after a short course of treatment (*vide* Observations 33 and 34). The number of cases hitherto treated is still too small to permit us to decide when it is best to begin treatment; *a priori*, I should say as early as possible, except in febrile cases, in which it is undoubtedly better to wait until the fever has subsided.

10. *Progressive muscular atrophy*, which may be regarded as a disseminated, progressive degeneration of the gray anterior horns, is characterized by a progressive, slowly spreading, degenerative atrophy of a large part of the voluntary muscles, with fibrillary twitchings, followed later by paralysis and disappearance of the muscles, without disturbance of sensation, the sphincters, brain, and cerebral nerves; not infrequently it is finally combined with progressive bulbar paralysis.

The electrical examination is very important in making a differential diagnosis. At the onset of the disease there is generally no distinct

anomaly and even after its long continuance many nerves and muscles merely present simple diminution of faradic and galvanic excitability corresponding to the degree of atrophy. As the degeneration progresses, however, indications of the De R make their appearance in certain muscles, and gradually become more distinct.

At first we find merely a partial De R, *i.e.*, the faradic irritability is diminished but not extinguished, while the galvanic excitability of the muscles is affected in the characteristic manner, *i.e.*, delay in the contraction, predominance of the An Cl C, but usually great diminution of irritability; at a later stage, complete De R is observed. This change is usually found in the small muscles of the hand, but occasionally in others; I must insist upon my view that De R occurs uniformly in all cases of progressive muscular atrophy. In many cases, however, it is not readily demonstrable and requires very careful examination and great skill in the recognition of the De R. This is due to the anatomical peculiarity of the disease, inasmuch as a number of healthy fibres are always found alongside the degenerated ones, and, the irritability of the motor nerves being retained, the qualitative changes may be concealed by the contractions of the healthy fibres. In the examination you must, therefore, employ all those devices to which I have previously called attention (page 87).

In one form of progressive muscular atrophy, *viz.*, that beginning in childhood and youth (juvenile form), I have never observed the degeneration reaction, but merely a simple diminution of faradic and galvanic excitability corresponding to the degree of atrophy. I regard this variety of the disease as distinct from the typical form.

Electricity has always been recognized as the most important if not the sole means of treatment in progressive muscular atrophy. In its typical form, however, this disease may be regarded as incurable; the reports of recoveries from the affection probably depend upon errors in diagnosis. In a few cases I have obtained improvement, even a temporary stand-still of the affection. The "juvenile form," referred to above, offers a much better prognosis.

In accordance with our views regarding the nature of the disease, galvanization of the spinal cord must play the chief part in the electrical treatment. The sympathetic may also be included in the treatment, especially when the disease is located in the cervical portion of the cord. The localization of the atrophy in the various groups of muscles furnishes us with accurate data concerning the site of the disease in the spinal cord, and the electrical treatment consists essentially of the stable application of both poles with moderately strong currents to the diseased parts of the cord. In addition, moderately strong galvanization or faradization of the neuro-muscular tracts which are chiefly affected (Ca labile, An over the site of the disease). In peripheral applications you should avoid too strong currents, as excessive irritation might hasten the degenerative pro-

cess in the muscles. This point can be determined ordinarily by the condition of the patient after each sitting. The treatment should be continued until its uselessness has been demonstrated.

The galvanic treatment of *amyotrophic lateral sclerosis*, which possesses an undoubted relationship to progressive muscular atrophy and is characterized by simultaneous sclerosis of the pyramidal tracts (symptoms of spastic spinal paralysis) should be conducted essentially according to the same principles, especial consideration being paid to the funicular degeneration which requires an action upon the entire cord. In this disease partial De R is observed more or less distinctly in the upper atrophic extremities, but there is no noteworthy change in the lower paretic and non-atrophied limbs. The prognosis of this affection appears to be as unfavorable as that of progressive muscular atrophy.

11. In *acute ascending paralysis*, a form of disease which has not yet been defined with precision either clinically or anatomically, very favorable effects from the use of electricity have been observed during the stage of convalescence. It is said to be characteristic of this disease, at least in typical cases, that the electrical irritability remains perfectly intact, but its relations to the ascending form of subacute anterior poliomyelitis still remain to be definitely ascertained.

It is a question whether the electrical current should not be employed even in the early stages of the disease, while it is still progressive; *a priori*, this seems to me to be justifiable. I would recommend the application of moderately strong stable currents along the entire spinal column for three to five minutes, either daily or even twice a day.

12. *Secondary degenerations of the spinal cord* have rarely been subjected to electrical treatment. Indeed, very little can be hoped for if the primary disease persists. There can be very little question of treatment of *ascending* secondary degenerations, since they can not be diagnosed because they do not produce any symptoms to our knowledge.

This does not hold good, however, of the *descending secondary degenerations of the pyramidal tracts*, especially in cerebral diseases (hemorrhages, softening, etc.). It is generally assumed that this degeneration exerts a certain influence upon the symptomatology, giving rise to an exaggeration of the tendon reflexes and the later paralytic contractures in the paralyzed parts; the latter often offer an obstacle to the return of mobility. Relief of the secondary degeneration may benefit the patient, accordingly, in certain cases, especially when the primary disease has improved. In such an event the galvanic current may be recommended. The method which may be employed is the same as in all systemic degenerations of the cord; the stable protracted application of the An to the entire spine, the Ca being placed over the cervical sympathetic; in older cases this may be followed by the application of the Ca to the spine.

III. DISEASES OF THE PERIPHERAL NERVES.

LECTURE XX.

Introduction—Available Current Effects in Diseases of the Peripheral Nerves—Practical Experience: Cases—Technique and Methods of Electrical Treatment—Individual Forms of Disease: Neuritis; Hemorrhages and Circulatory Disorders; Slight Mechanical and Traumatic Lesions; Severe Traumatic Lesions; Degenerative Atrophy of the Nerves; Functional Disorders—Symptomatic Treatment—Electro-diagnostic Remarks.

I WILL now turn to the consideration of the anatomical lesions and diseases of the peripheral nerves, apart from their individual symptoms, such as spasm or paralysis, neuralgia or anæsthesia, etc. Concerning the molecular nutritive disturbances which are frequent causes of disordered function, and give rise especially to neuralgia, spasms, perhaps also paralysis, we can only speak in passing.

We have to deal here with very few morbid processes, viz., sub acute and chronic forms of neuritis, next the rare circulatory disorders, anæmia and hyperæmia, and the much rarer hemorrhages into the nerves. Then we have to deal with the mechanical and traumatic lesions of the nerves, in all their varying degrees of severity, and finally with degenerative atrophy, which is usually secondary, but occasionally, perhaps, occurs primarily in the form of chronic parenchymatous neuritis.

If you bear in mind our previous discussions, you will readily see that any favorable effect of electricity in these various affections of the peripheral nerves must depend mainly upon its catalytic actions, upon its effects on circulation and nutrition, upon inflammation and its consequences; to this category belong also the effects upon cicatricial tissue, upon cirrhosis and degeneration, the absorption of extravasations and exudations into the nerves and nerve-sheaths, finally the effects upon the molecular or nutritive disturbances produced by pressure of short duration or by moderate compression; the catalytic action of the current may be of service in all these conditions.

The vasomotor effects of the current are also undoubtedly beneficial in hyperæmia and anæmia of the nerves, or when it is necessary to stimulate nutrition or combat degenerative atrophy. The stimulating and modify-

ing actions of the current may, perhaps, be useful in relieving local nutritive disturbances.

The following series of cases will serve to illustrate the effects of electrical treatment :

36. *Personal observation. Chronic neuritis of the median nerve.*—A woman, aged forty years. Suffered for a year and a quarter from neuritis of the median nerve above the right wrist. It began with numbness in the first four fingers, then pains in this region, which increased until they prevented sleep. The median nerve above the wrist is felt as a thickened, spindle-shaped band, which is tender on pressure ; this also causes pain and formication in the entire distribution of the nerve ; the latter presents trophic disturbances of the skin. The pain is localized, burning, continuous, but occasionally exacerbating ; no anaesthesia ; the hand grows tired very easily. Faradic and galvanic excitability of the nerve somewhat increased. Galvanic treatment. An stable upon the nerve above the wrist and in the fold of the elbow. Considerable improvement after the second sitting. After the tenth sitting, the patient slept the entire night ; feeling in the hand much more normal ; pain much lessened. The swelling of the nerve constantly diminished. Complete recovery in all respects after seventy sittings.

37. *Personal observation. Chronic neuritis nodosa (neuroma?) of the ulnar nerve.*—An engineer, aged twenty-five years. Had a dislocation of the right elbow twenty years previously, leaving slight deformity, but complete usefulness. Had formication in the little finger of the right hand for eight years after protracted writing or drawing (mechanical irritation of the ulnar nerve by the dislocated internal condyle). For two years, weakness and wasting of some of the small muscles of the hand ; for a year, constant feeling of numbness in the little finger and a deep-seated pain in the fourth finger. Status : the hypothenar eminence of the right hand, the adductor pollicis and most of the interossei completely paralyzed and atrophic ; other muscles normal. Complete De R in the paralyzed muscles. Sensibility in the ulnar distribution somewhat diminished. At the elbow-joint the ulnar nerve presents a distinct, spindle-shaped thickening, about as large as a bean. Galvanic treatment : An stable upon this swelling, the Ca alternately above and below it ; a few changes of polarity ; then labile application of the Ca to the distribution of the ulnar nerve (An upon the swelling). After fifteen sittings, constant and progressive improvement ; the movements of the hypothenar eminence, adductor brevis pollicis, and most interossei (with the exception of that of the fourth finger) have returned. Return of the faradic irritability of the ulnar nerve above the wrist, but not of the muscles. Feeling of numbness markedly diminished ; enlargement of the ulnar unchanged. Patient is discharged. Improvement occurred later.

38. *Personal observation. Neuritis of the brachial plexus ; combined shoulder-arm paralysis (Erb).*—A man, aged fifty-two years. Taken sick five weeks ago with pain and stiffness in the back of the neck, then had pain in shoulder and arm, with paræsthesia in the thumb and index finger ; progressive paralysis of the arm. Examination shows complete paralysis and marked atrophy of deltoid, biceps, brachialis internus, and supinator longus ; supinator brevis also appears to be weak. Tactile sensation somewhat blunted on thumb and index finger. A few tender spots in left

supra-clavicular fossa. Electrical irritability slightly diminished. Galvanic treatment: An stabile to brachial plexus, galvanization of sympathetic and descending labile through the paralyzed muscles and nerves. Complete recovery after thirty-five sittings.

39. *Observation by R. Remak. Paralysis of the deltoid; neuritis of the brachial plexus.*—A man, aged thirty-one years. Rheumatism of the three large joints of right arm for three months; two months ago, sudden complete paralysis of right deltoid, which resisted all therapeutic measures (faradization, blisters). Distinct, tender swelling of the brachial plexus, especially of that part from which the circumflex arises. No immediate effect from labile application of Ca to the muscle. Stabile application of An (two to three minutes) to the painful part of the plexus enables the patient at once to raise the arm to the vertical; the swelling then appeared less painful. Two further applications of the current completed the recovery.

40. *Personal observation. Traumatic paralysis of the left arm (from dislocation of the shoulder).*—A man, aged sixty-three years. October 23, 1869, dislocation of left shoulder; immediate paralysis of arm; marked anaesthesia of arm at first, which is now somewhat improved.

February 23, 1870.—Complete paralysis of left forearm and hand; triceps almost completely paralyzed, biceps and brachialis internus normal. Complete De R in paralyzed muscles. Sensibility diminished in hand and radial side of forearm. Galvanic treatment: An stabile through the shoulder-joint, then Ca labile through the nerves and muscles.

March 3d.—While the Ca is in axilla, a slight voluntary contraction occurs in the flexor muscles of forearm.

March 29th.—While An is stabile in the axilla, a slight movement occurs in extensor muscles of forearm, and traces of contraction on attempting to contract these muscles voluntarily; their power of motion increases perceptibly during the next few days. The arm and hand, which had been swollen, bluish red, and cold, look much better.

April 6th.—Patient discontinues treatment; markedly improved.

June.—The improvement has advanced still further.

41. *Personal observation. Paralysis of the right radial nerve (neuritis? trauma?).*—A man, aged forty-five years. December 26, 1874, sudden paralysis of right radial nerve, with formication in its distribution to the hand; faradization useless.

Status on February 15, 1875: Paralysis of entire radial distribution in forearm; sensibility unaffected. Electrical examination proves the site of the lesion to be in the region where the nerve bends around the elbow (interruption of conduction); below this locality the distribution of the nerve presents partial De R; no contraction can be obtained through the nerve above this point. Galvanic treatment: An in the neck, Ca stabile over the site of the lesion (with a few changes of polarity), then labile through the nerve and muscles. Considerable improvement after the fourth sitting, especially in the supinator longus, extensores radialis and digitorum. Complete recovery after twenty-two sittings; electrical irritability nearly normal.

42. *Observation by Mor. Meyer. Neuralgia (neuritis?) of the brachial plexus.*—A girl, aged fourteen years. Pain for nine months in fourth interosseous space of right hand, which gradually extended over arm and forearm in the course of the radial nerve; a small, thickened, painful spot in outer part of brachial plexus. Immediate relief from stabile application of An to this spot; recovery after seventeen sittings.

43. *Observation by Mor. Meyer. Neuralgia (neuritis?) of the ulnar nerve.*—A girl, aged nineteen years. Pain for three years in fourth right metacarpal space and along the course of the cutaneous branch of the ulnar nerve to the elbow and to the right side of the neck; inability to use the arm. Great tenderness of lower part of brachial plexus. Application of An to this region produced considerable improvement after four sittings; not completely cured until fifty-four sittings.

44. *Personal observation. Right occipital and trigeminal neuralgia (neuritis?).*—A compositor, aged twenty-four years. April, 1872, severe supra-orbital and infraorbital neuralgia cured by four applications of An stabile.

June, 1872.—Neuralgia of both trigemini and occipitalis cured in a few days by An stabile.

August, 1873.—For two weeks has had pain in right ear, right side of face, and right half of occiput and scalp; feeling of numbness in these parts. No painful point in the face, but one in the course of the occipitalis major nerve. Moderate anæsthesia throughout the painful region. Galvanic treatment: An stabile in front of the ear and on the occiput, the current being gradually increased and decreased. Cured in ten sittings.

45. *Personal observation. Left sciatica; anæsthesia (neuritis?).*—A porter, aged forty-three years. Four weeks ago had severe pain in the back, which disappeared after some vapor baths; then very violent pains for two weeks in left thigh and foot; was then free from pain for a week, but had feeling of numbness throughout the left leg in the distribution of the sciatic, with weakness of the limb. Status: dragging gait; leg very weak; sensibility diminished in sciatic distribution; marked feeling of coldness in the limb, which also feels colder than its fellow. Galvanic treatment: Descending stabile current, with a few closures. After fifteen sittings: pain and numbness entirely disappeared; sensibility also normal objectively. Discharged cured, and has remained so since.

46. *Personal observation. Right supraorbital neuralgia.*—A glove maker, aged twenty-six years. For five days past, violent neuralgic pains in right supraorbital nerve; relief at night; very marked point douloureux at the supraorbital foramen, nerve sensitive to pressure throughout its entire extent. No sensory disturbance. Galvanic treatment: 8 elements gradually increased and diminished, An stabile upon the nerve-trunk, Ca upon the left hand; pain disappeared immediately afterward. Cured after two more sittings. Painful point had disappeared after first sitting.

47. *Personal observation. Neuralgia of the superficial branch of the left radial nerve.*—A servant, aged thirty-three years. Has suffered for a week from the most violent pains in the distribution of and along the left superficial radial nerve, beginning at 4 p.m. and lasting during the entire night. Movements of the hand and fingers performed with difficulty during the paroxysms. For six days, numbness in distribution of nerve to the hand. Painful point upon the nerve. Galvanic treatment: descending current, stabile through the nerves, three to four minutes. The pain did not return after the first sitting; merely slight twinges, which disappeared after two more sittings.

48. *Personal observation. Trigeminal neuralgia; herpes labialis.*—A servant, aged twenty-four years. Sick for past three days with vomiting, headache and some fever; since yesterday very violent pain in left half of face. Painful points at the supraorbital and infraorbital foramina. Herpes of the left lower lip.

March 21st.—Galvanic treatment; stabile from the mastoid fossa to

the supraorbital, infraorbital, and mental foramina ; a few closures of the current. Great relief experienced immediately.

March 26th.—Discharged cured.

49. *Observation by Leber. Retrobulbar optic neuritis.*—A boy, aged nineteen years. The disease has continued unchanged for eight months despite all treatment ; then striking and very rapid improvement and almost complete restoration in one eye during galvanization of the sympathetic (An over the superior ganglion), while transverse conduction of the current through the temples had proven fruitless. An improvement in sight could be noticed after each sitting.

50. *Observation by Donald Fraser. White atrophy of the optic nerve.*—A man, aged fifty-nine years. Diminution of vision for past five years.

September, 1871.—Right eye Sn 20 at four inches, left eye at eight inches. Ophthalmoscopic examination : the external two-thirds of the optic nerve white and shining, the inner third congested ; the veins tortuous and wide, the arteries diminished in number and calibre ; white streaks along some of the vessels. Diagnosis : primary degeneration of the optic nerve. Treated unsuccessfully for a month with mercury and iodine.

October, 1871.—Sn 20 with both eyes at seven and a half inches. Galvanization with 6 elements through the temples for twenty seconds ; immediately afterward, Sn 20 at ten inches. Treatment : longitudinal and transverse conduction of the current through the head. Progressive improvement at the end of three months, Sn 5½ seen as readily as Sn 20 at the beginning.

January, 1872.—Distinct improvement also in the ophthalmoscopic appearances, the arteries wider, the veins narrower and less tortuous. The improvement makes still further progress.

As in diseases of the brain and spinal cord, so in those of the peripheral nerves, we must rely almost exclusively for the production of catalytic and vasomotor effects upon the galvanic current ; the faradic current may perhaps be available, like the galvanic, in the production of stimulating and modifying effects, and to relieve molecular, nutritive disturbances.

In the majority of cases we must apply treatment as directly as possible to the diseased part, though an indirect effect cannot be excluded, inasmuch as it is possible to set in action vasomotor and even trophic influences from parts of the nerve situated superiorly or from the sympathetic system (cervical sympathetic in optic neuritis) or even from the spinal cord and its centres ; and finally a reflex action from the skin (faradic brush, etc.) may not be useless, especially in functional, molecular changes (for example, in neuralgia).

The following methods of application may be employed in the special forms of disease of the peripheral nerves :

In neuritis, at least in more recent cases, the most favorable effect is obtained from the stable application of the An, the Ca being placed either directly opposite or upon some indifferent spot (sternum) ; it appears to me more advisable to place the Ca upon a more central portion of the af-

affected nerve or upon the corresponding portion of the spinal cord in order to affect the vasomotor (and trophic?) nerves. Moderately strong currents (25° to 40° deflection of the needle with 150 C R) are employed and allowed to act from two to ten minutes according to circumstances. In older, more chronic cases (*vide* Observation 37), in which induration and cirrhosis with advanced degenerative atrophy are present, the An is used alternately with the Ca, the latter perhaps to a greater extent and with greater intensity. The same methods may be employed in hemorrhages into the nerve-sheaths, which occur and are recognized with equal infrequency.

In mild mechanical and traumatic lesions it has been ascertained with certainty that the direct application of the galvanic current to the site of lesion is useful, and that distinct improvement sometimes occurs immediately after its employment. This favorable effect is especially secured by the stabile application of the Ca of a feeble galvanic current. An indirect vasomotor or catalytic effect may also be sought for by galvanizing the central portion of the nerve. Moderate faradic currents are also admissible for the same purpose, and may also be useful in a reflex manner (faradic brush).

In severe traumatic lesions a favorable effect from the electrical current can only be looked for when the cause is removed; in part this may be done by the absorbing, catalytic action of the current itself (in cicatricial formations, incised wounds and the like), but the treatment of the cicatrix of the nerve, the furtherance of the union of both ends of the divided nerve do not appear to be entirely useless. The site of the lesion must then be treated vigorously and for a long time with stabile currents, the An and Ca being applied successively; in older cases, the Ca stabile and labile should be also applied to the central end of the nerve.

The degenerative atrophy of the nerves must also be treated forthwith in such cases. Experience teaches, however, that there is no hope of success unless central trophic influences are not entirely excluded or have been restored to a certain extent, since the development of degenerative atrophy cannot be prevented. Real success can be expected in such cases alone in which the original lesion of the nerve has been so far relieved that some connection has been restored between the peripheral and central portions of the nerve. In all such cases of secondary degenerative atrophy (recognizable by the De R), treatment of the site of the lesion is the most important, that of the degenerative atrophy merely secondary. When we have to deal with primary degenerative atrophy (so-called parenchymatous chronic neuritis), its treatment is the most important.

In both events, it is our object to hasten the regeneration of the nerve-fibres. The most suitable method is vigorous galvanization of the nerve-trunk throughout its entire extent: I first apply the An stabile, then chiefly the Ca, passing it labile along the nerve-trunk; moderately strong

current for one to four minutes daily along each nerve. The same method is employed upon the muscles supplied by the diseased nerves.

As soon as practicable—forthwith in the primary forms, and as soon as we suspect the restoration of trophic conduction in the secondary forms—it is well to treat also the central portion of the nerve or the corresponding centres in the spinal cord, in order to hasten the healing process in the peripheral part by stimulation of the vasomotor and trophic paths and centres.

The choice of currents in the treatment of purely functional disorders of the peripheral nerves (neuralgia, anæsthesia, spasms, certain paralyses, etc.), will depend upon the indications present, and these will be discussed in the subsequent lectures.

Very few remarks are necessary with regard to electrical irritability in lesions of the peripheral nerves. The electrical examination is very important with regard to the localization of the lesion, when the position at which conduction is interrupted can be ascertained. If the irritability of a motor nerve is retained below the site of the lesion, but is lost above this point, the exact location of the morbid process is readily ascertained, as it is also when, in a sensory nerve, no eccentric sensations can be produced below a certain spot, but are preserved above it.

All possible changes of electrical irritability may occur, as you will remember from our previous remarks on general electro-diagnosis.

IV. PARALYSIS AND ATROPHY.

LECTURE XXI.

Definition and Pathogenesis of Paralysis—Objects of Electro-therapeutics in Paralysis and the Methods of Effecting them: a. Removal of the Cause of Paralysis—b. Removal of Obstructions to Motor Conduction; Direct and Indirect Method; Utilization of Reflex Paths; Method of Application of the Faradic and Galvanic Currents for these Purposes—c. Relief of Finer or Grosser Nutritive Disturbances in the Motor Conducting Paths—d. Restoration of the Normal Condition of the Paralyzed Muscles—Treatment of Muscular Atrophy—Results of Electro-therapeutics in Paralysis—Electro-diagnosis of Paralyses—Practical Technical Remarks.

PARALYSIS may be defined as “a diminution or extinction of the power of stimulating the motor nerves and muscles to their normal functions.”

This condition may be produced by disease of the muscles themselves (atrophy, degeneration, diminished irritability from certain poisons, etc.), and then constitutes so-called myopathic paralysis. Or paralysis may be due to disease of the motor tracts at any part of their course from the muscles to the motor centres of the cerebral cortex and to disease of the latter centres themselves; this is neuropathic paralysis.

The latter form may be due to various causes which impair the function of the ganglion cells and nerve-fibres, viz. : inflammation, degeneration and atrophy, hemorrhage, anæmia and hyperæmia, perhaps most frequently to simple mechanical actions, such as compression, rupture, division, etc. ; in addition, to less palpable, not gross, anatomical changes, such as the action of certain poisons, exhaustion, exposure, hysteria, etc. —in short, to so-called “functional” disturbances of whose material basis we are yet ignorant.

This does not exhaust all the phenomena occurring in paralysis and which are occasionally the subject of our therapeutical efforts. Certain changes and sequelæ may develop in the paralyzed parts, the nerves and muscles; they are frequently of a simple, nutritive, molecular character, and are manifested by diminished power of conduction and excitability—at most by simple wasting. They are due in part to disuse, in part to the absence of certain trophic stimulations. Not infrequently, however, these disturbances are of a much more serious character, constituting degenera-

tive atrophy of the nerves and muscles and advancing to marked fibrous cirrhosis.

The object of electrical treatment in all these pathological processes is the restoration of the normal influence of the will upon the muscles, *i.e.*, in the large majority of cases, the restoration of conduction in the motor nerve-tracts; in a smaller number of cases, the restoration of the irritability, contractile power, and nutrition of the muscles; in almost all cases, in addition, we are required to relieve the changes in the nerves and muscles consequent upon the paralysis.

a. Our most important object is the removal of the cause of paralysis, *i.e.*, the local lesion of the diseased part of the motor conducting path. Only a part of these morbid processes is accessible to electro-therapeutics, such as the manifold diseases of the brain, spinal cord, and peripheral nerves which I have discussed in the preceding lectures (Lectures XV.-XX.). If these have produced the paralysis, they must be treated in the manner already described.

Another part of these causes of paralysis is inaccessible to electro-therapeutics and must therefore be treated by other means (internal remedies, surgical measures, baths, etc.).

Finally, another series of cases remains in which we do not know the exact nature and location of the morbid process (hysteria, various forms of poisoning, certain paralyzes after acute diseases, etc.). Causal treatment must then be dispensed with or directed to all localities which may possibly come in question.

b. The fulfilment of the causal indication often effects our second object, *viz.*: the removal of the obstructions which prevent the conduction of stimulation through the site of the lesion. But the latter indication is not always met in this manner, and we must then rely upon the direct anti-paralytic action of electrical currents.

For this purpose their stimulating action is all important. An obstruction to motor conduction which cannot be relieved by the stimulus of the will may perhaps be overcome by a more vigorous artificial stimulus and thus the path also made free to voluntary excitation. If the electrical irritant is allowed to act vigorously on the proximal side of the lesion, the obstruction may, perhaps, be removed in this manner. In explanation of this phenomenon, I would refer to the well-known fact that frequent use of a motor conducting path diminishes the resistance of the latter (influence of practice). In this manner we sometimes succeed in forcing the conduction of the process of excitation by means of the electrical current; when this has been achieved, the stimulus of the will may gradually grow effective and the paralysis slowly disappear.

As a matter of course, the stimulus must be applied to the proximal side of the lesion (Fig. 35); in order to remove an obstruction (*a*) in the conducting path of a motor nerve (*n*), so that the centrifugal voluntary

process of stimulation may reach the muscle (*m*) undisturbed, the electrical stimulus (*e*) must be applied to the proximal side of the site of the lesion (*a*). Frequently, however, this cannot be done, even in peripheral paralysis—for example, in paralysis of the facial nerve within the Fallopian canal, or of the cerebral nerves at the base of the skull, or in lesions of the cauda equina, etc. Our purpose could not be achieved were it not for the fact that we are fortunately in the position of exerting the electrical stimu-



FIG. 35.

FIG. 35.—Schematic representation of a motor paralysis. *m*, motor conducting path; *m*, muscle; *a*, site of lesion, obstruction to motor conduction; *e*, electrical irritant applied to central side of site of lesion.

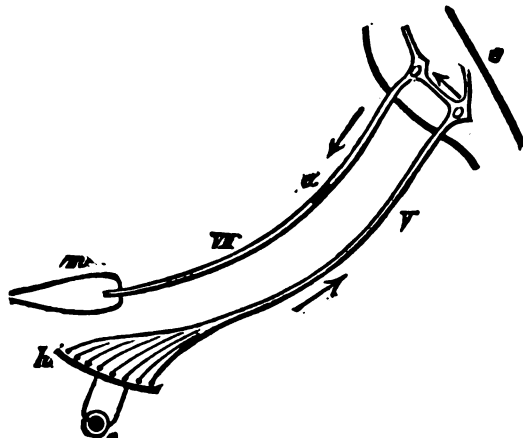

FIG. 36.

FIG. 36.—Schematic representation of a peripheral facial paralysis and its reflex electrical stimulation from the trigeminal. *VII*, facial nerve; *V*, trigeminal; *m*, muscle; *h*, skin, peripheral distribution of trigeminal; *c*, central organ (medulla oblongata); *a*, site of lesion in the facial nerve; *e*, electrical stimulus, applied to the skin. The electrical stimulant process runs in the direction of the arrows.

lation in the desired locality—on the proximal side of the lesion—in an indirect, reflex manner.

The matter is very simple when the shortest and most frequently employed reflex arc is intact; for example, in facial paralysis so long as the trigeminal is intact (*vide* Fig. 36). If an obstruction to conduction (*a*) is present in the facial nerve (*VII*) near its entrance into the Fallopian canal, the electrical current cannot be applied to the proximal side of the lesion with sufficient intensity. But if we irritate the integument of the face (*h*), which is innervated by the trigeminal (*V*) with the electrical current (*e*)—or the trunk or individual branches of this nerve—a centripetal

stimulation is produced which is conveyed in the central organ (*c*) through the shortest reflex arc to the trunk of the facial, and now acts as a centripetal stimulus upon the obstruction to conduction, in the same manner as if the electrical irritant had been applied centrally.

A somewhat similar condition occurs in infantile spinal paralysis, in which the obstruction to conduction is situated in the reflex arc itself, but the sensibility of the skin remains intact; a central irritation of the motor paths of conduction is also impossible in this instance, but the process of reflex stimulation may be resorted to, as will appear from the adjoining figure without further explanation.

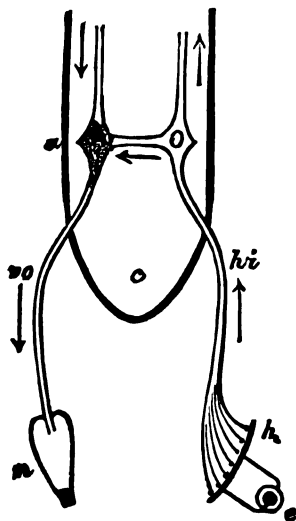

FIG. 37.—Schematic representation of a central paralysis, for example infantile spinal paralysis. *c*, central organ; *m*, muscle; *A*, skin; *e*, electrical irritant; *A*, sensory conduction and posterior roots; *no*, motor conduction and anterior roots; *a*, site of lesion situated within the reflex arc.

of *h*: the obstruction to sensory conduction at *a* can be overcome and therefore made free, so that the shortest reflex path is now opened for the centrifugal stimulation of the path *Rm*. A more direct action upon the paralysis is thus rendered possible. This may also prove of service when, as so often occurs, the sensory conduction is restored earlier than the motor; the sensory paths may then be employed forthwith for reflex irritation.

The matter becomes still more complicated in central paralyzes; if the shortest available reflex path is situated below the site of lesion (in Fig. 38, the reflex path *h' Rm'* when the lesion is located at *a'*), its irritation will have no direct influence upon the site of disease and therefore upon the paralysis, especially if sensory conduction is also impeded at the level of *a'*; it follows, therefore, that spinal and also cerebral paralyzes, in which the reflexes are retained or increased, cannot be influenced (or only with difficulty) in this reflex manner; this is only conceivable if, the sensory conduction being retained, the reflex irritation acts upon *a'* in a cen-

trifugal direction through a circuitous path or from more remote sensory paths; we must employ, in the main, the reflex paths which are situated more anteriorly. As reflexes can also be obtained from the cerebral cortex, it thus becomes possible, in paralyses of every possible location, to employ the reflex stimulation coming from the centres by electrical irritation of any part of the skin upon the paralyzed side. This is also facilitated by the fact that in many of the paralyses in question, the sensory conduction to the cerebral cortex is entirely intact. This will explain in part the successful results of peripheral faradization and galvanization in central, especially cerebral, paralyses, and it accords very well with the statements of Vulpian and Rumpf that the application of the faradic brush to the skin of the forearm, in hemiplegia with anæsthesia, may also improve the motor paralysis, speech, etc.

To secure these irritating effects, you may employ the various methods described in the general part of this work (page 105). In employing the galvanic current, the Ca should be applied, at first stabile, then labile, along the nerves and muscles which we desire to irritate. The contractions produced serve as a measure of the strength of current; in central stimulation, when, as a matter of course, no contractions occur, or when the peripheral part of the nerve is inexcitable, you should select the strength of current upon corresponding healthy nerves. To secure more vigorous irritations, make cathodal closures, and, if you require a still stronger stimulus, make repeated changes of polarity. The An may be placed at the site of the lesion, on its proximal side, or on some indifferent spot.

In using the faradic current, it is generally sufficient to apply it by means of moist electrodes to the nerve-trunks in question, upon the prox-

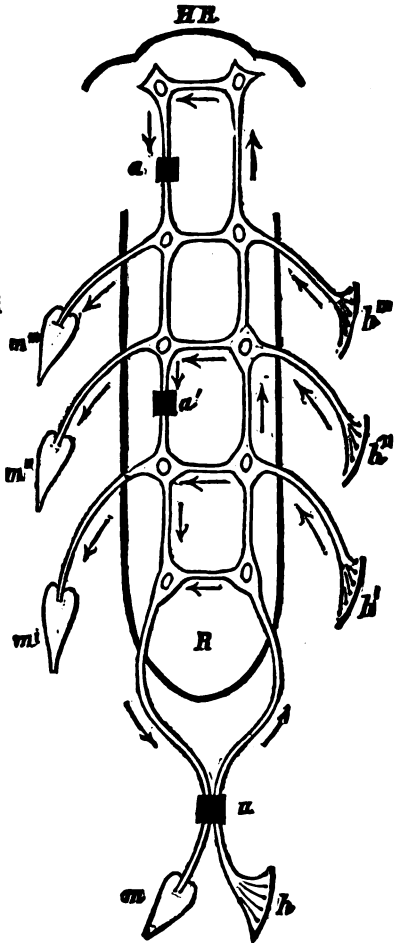

FIG. 33.—Schematic representation of the reflex paths available therapeutically in various peripheral and central paralyses. *R*, spinal cord; *HR*, cerebral cortex; *m m' m'' m'''*, motor paths and muscles; *A A' A'' A'''*, sensory paths and skin; *a*, lesion of a peripheral mixed nerve; *a''*, lesion of the spinal motor conducting paths; *a'''*, lesion of cerebral motor conducting paths.

imal side of the lesion when the motor paths are to be acted upon, upon the distal side when you wish to act upon the sensory paths. Or you may employ faradization of the skin, as in general faradization, or apply the faradic brush, either as a vigorous local application to certain small portions of the skin (Vulpian) or as a more diffuse application with a moderately strong current (Rumpf).

c. A further object is the removal of the secondary finer or grosser nutritive disturbances which may be present in the motor conducting paths and interfere with their normal function.

We may have to deal with finer molecular disturbances, such as are produced in the nerves by poisons, or by prolonged inaction, perhaps also by the exclusion of certain central trophic influences. A single or repeated moderate stimulation of the motor paths of conduction by the process of electrical irritation may then suffice to restore conduction.

Next in order is the degenerative atrophy of the nerves, which arises from the entire exclusion of central trophic influences and is recognized by the De R. Although entire prevention of this degenerative atrophy cannot be secured, it is probable that regular faradic and galvanic stimulation will, at least, prevent marked atrophy of the muscles and hasten the restoration of the nerves and muscular fibres. The galvanic current is preferable; stabile application of both poles to the diseased part of the nerve, then vigorous labile application, and in addition the treatment of the muscles which will next engage our consideration.

d. Our final object in many cases is the restoration of the normal irritability, contractility, power, and also the normal volume of the paralyzed muscles.

The surest means of improving the nutrition and contractility of the muscles is the process of muscular contraction itself; muscles which are often contracted become hypertrophic and stronger.

To effect our object, viz., the relief of the atrophy and degeneration of the muscles, we should endeavor to increase the irritability of the contractile substance, to produce repeated muscular contractions, to cause increased flow of blood to the muscles, and finally exert trophic influences upon them.

As you see, these objects appear to be created for electro-therapeutics, especially for the galvanic current; we may at first apply the Ca stabile, alternating with the An, upon the muscle itself; then an energetic stabile application of both poles, either alternately or simultaneously, upon the motor nerve of the muscle; finally, labile galvanization of the motor nerve and muscle. If more vigorous stimuli are required, cathodal closures and changes of polarity may be resorted to. In employing the faradic current, moist electrodes are applied to the muscles and their motor nerves according to the rules of local faradization.

I must also mention another method of treating muscular atrophy, viz.,

by the application of feeble, continuous currents (1 to 4 elements). Le Fort and Valtat have employed them especially in the muscular atrophy which is so frequent after inflammations of the joints. They appear to be especially indicated in the peculiar forms of muscular atrophy without degenerative processes and without De R, which may be attributed to reflex influences (particularly those starting from the joints), to prolonged inaction, continued use of surgical bandages, and the like; the muscles present simple diminution of faradic and galvanic excitability. With regard to the Le Fort-Valtat method of treatment, I refer you to my remarks on page 120.

A review of our previous considerations shows that we require chiefly the stimulating effects of electrical currents in the treatment of paralysis and atrophy, and next their catalytic effects (which play the chief part in the fulfilment of the causal indication), but that the modifying effects are of minor importance.

As the same method of application will suffice for all the indications which are to be met, the electro-therapeutics of paralysis is very much simplified. Apart from the methods required by the causal indication (treatment of the brain, sympathetic, spinal cord, or the lesions of the peripheral nerves) the direct antiparalytic effects of the current can be secured, as a rule, by simple faradization of the affected nerve-trunks, or by the labile (most prominently), then stabile galvanization of these nerves. In addition, it is sometimes desirable to employ peripheral cutaneous irritation of such sensory nerve-trunks as have not been affected by the other procedures.

These applications produce more or less rapid and complete results; in especially favorable cases this may occur after one or more sittings when the anatomical conditions are of such a character that rapid restoration of conduction is possible or the way for it has been already prepared by the restorative processes of nature. We may then observe the sudden return of movements, which were perhaps impossible for weeks and months, as, for example, in paralysis of the vocal cords, hysterical paralysis, certain cerebral paralyses, mild rheumatic paralysis, even in paralyses which manifest the De R, if the electrization is first employed at the period when regeneration has made a certain amount of progress. But such cases are exceptional and the majority of paralyses require more or less prolonged treatment.

A few remarks will suffice with regard to the electro-diagnosis of paralyses, and I will merely give a short *résumé* of the subject (*vide Lectures VII-X*).

We very often expect that electrical examination will give us information with regard to the exact site of the paralysis, but our expectations are rarely realized. This can sometimes be done in peripheral paralyses when the central part of the nerve is accessible to electrical stimulation; if this is inexcitable electrically, while a more peripheral portion is ex-

citable, the lesion must be situated between the two points of irritation (even this is only available in cases in which complete De R is not present). Furthermore we may conclude from the presence of severe disturbances of electrical irritability (marked diminution, De R) that no true cerebral paralysis is present, since these changes occur alone in spinal (including bulbar) and peripheral paralyses. A differentiation between peripheral and spinal paralysis, on the other hand, is not possible from the electrical examination alone; but if the paralysis is of undoubted spinal origin you may draw a conclusion with regard to the implication of certain parts of the gray anterior horns from the presence or absence of the De R.

Much more important are the data furnished us by electrical examination with regard to the presence or absence of severe degenerative processes in the paralyzed nerves and muscles, and here the various forms and stages of the De R are of the greatest significance, because they furnish pretty accurate data concerning the histological condition of the nerves and muscles. For further details on the subject I refer you to the general part of this work.

Finally, slighter changes (simple increase or diminution of electrical excitability) occur, from which certain inferences may be drawn with regard to finer molecular and nutritive disturbances which occasionally justify important conclusions, although of slight diagnostic value. Thus, slight increase of excitability, which occurs in some paralyses a few days after their development, in others persists for a long period, leads us to infer the existence of slight irritative processes in some part of the motor tract (as in hemiplegia with contracture, in neuritic paralysis, at the onset of certain rheumatic paralyses, etc.). In some cases a diminution of excitability leads us to infer finer nutritive disturbances (from inaction, the exclusion of certain trophic influences in some spinal and cerebral affections which do not lead to De R); in other cases, the atrophy of a large number of nerve and muscular fibres, such as is observed in bulbar paralysis and progressive muscular atrophy in a part of the muscles; or, finally, there are grosser changes in the muscles themselves, which cause atrophy or other disturbances and thus lead to a diminution of excitability (for example, in the muscular atrophy around diseased joints, in primary diseases of the muscles, such as lipomatosis, pseudo-hypertrophy and true hypertrophy of the muscles, etc.). From all that we know, the existence of the De R indicates that the paralysis or atrophy is neurotic in its origin (from a lesion of the peripheral or central trophic nervous apparatus); in all cases, therefore, in which marked atrophy and paralysis are found without De R, you may exclude their neurotic origin with some certainty, and regard them as due to a primary disease of the muscles; at all events, serious lesions of the gray anterior columns or the peripheral tract may be positively excluded, although the possibility of another form of central disturbance of nutrition is not entirely excluded (*vide* pages 73, 74).

Before proceeding to a detailed consideration of the individual forms of paralysis, I will make a few general and practical remarks.

Central application is naturally the main feature in the treatment of *cerebral paralysis*; concerning the method I refer you to Lectures XV. and XVI. In the peripheral treatment of the paralysis we must depart from the principle of applying the An to the site of lesion, on account of the danger of strong currents to the brain; in such cases I usually apply the An to the back of the neck, while the arm and leg are treated peripherally. As an introduction to peripheral treatment I have sometimes allowed feeble, stabile currents to pass from the side of the brain lesion to the opposite paralyzed brachial plexus. Caution in choosing the strength of current is especially necessary in cerebral paralysis, particularly when reflex irritation (farado-cutaneous brush) is employed.

Central treatment is also most important in *spinal paralysis*; peripheral treatment may sometimes be dispensed with entirely, especially when the nutrition of the muscles is normal. In these cases we may adhere to the rule of applying the An to the site of lesion in the peripheral treatment.

In *peripheral paralysis* chief consideration must also be paid to the site of lesion; the special conditions of the case will determine the position and character of the applications; the differences in effect upon the motor and sensory tracts, the applicability of direct or reflex stimulation must not be left out of account.

Very little need be added with regard to the technique of the applications; the strength of the current varies with the individual cases, and is usually chosen so that contractions will be produced; the choice of electrodes is made according to general principles, in causal treatment as large as possible, in peripheral treatment the active electrode being relatively small.

The duration of the sitting should not be too great, since exhaustion may otherwise occur.

LECTURE XXII.

Electro-therapeutics of Individual Forms of Paralysis—1. Paralysis of the Ocular Muscles: Pathogenesis; Cases; Methods of Treatment; Results—2. Paralysis of the Muscles of Mastication—3. Paralysis of the Facial Nerve—Rheumatic Form; its Situation and Nature; Condition of Electrical Excitability; Prognosis; Cases; Methods of Treatment; Results—Other Forms of Facial Paralysis—4. Paralysis of the Spinal Accessory Nerve—5. Paralysis of the Hypoglossal Nerve.

1. PARALYSIS OF THE OCULAR MUSCLES.

THIS occurs very frequently, either as an isolated affection or as a part symptom of serious diseases of the brain and also the spinal cord.

The electrical treatment must depend upon the most exact diagnosis possible concerning the form and distribution of the paralysis, and especially the localization of the lesion. The recognition of the paralysis of individual ocular muscles has reached a high grade of perfection. There may be isolated paralysis of single muscles or of individual nerves, partial paralysis of the motor oculi nerve; combined paralysees of all or of two of the nerves, unilateral and bilateral paralysis, and finally bilateral paralysis of associated muscles; in addition, we must differentiate between complete paralysis and mere paresis or so-called insufficiency of the ocular muscles.

The exact location of the lesion may be determined in many cases from these relations, from the etiological factors, and from certain clinical data. The lesion may be situated in the orbit (affection of the three ocular nerves, the optic and first branch of the trigeminus) or in the middle fossa of the skull (affection of the three ocular nerves, and the entire trigeminus), or in the posterior fossa of the skull (implication of the trochlearis, abducens, facial, acoustic nerves, etc.); or it may be situated in the bulbar nuclear region, in the medulla oblongata, pons, peduncle (nuclear paralysis of the ocular muscles, implication of muscles which belong together functionally, non-implication of accommodation and pupillary reflexes, implication of other bulbar nerves, alternating paralysis, etc.). Very little is known concerning more central lesions as causes of ocular paralysis; some observations seem to indicate that they may be due to lesions of the cortex on the opposite side.

It is of great importance to determine whether the paralysees should be regarded as prodromata or part symptoms of some other disease, especially

locomotor ataxia, multiple sclerosis, and the like. It is also desirable to obtain information with regard to the character of the lesion, since in certain disorders (tumor, syphilis, etc.) little or nothing can be expected from the electrical current.

There is no electro-diagnosis of ocular paralyses, as the muscles cannot be excited electrically.

I append a few cases as illustrations of the therapeutical results :

51. *Personal observation. Rheumatic paralysis of the abducens.*—An engineer, aged thirty-four years. Suffering for ten days from diplopia, probably from exposure. Paralysis of the right abducens; the eye cannot be moved outward beyond the median line. Galvanic treatment: 8 elements, stable transversely through the temples, galvanization of the sympathetic, Ca labile along the region of the external rectus (An on the left side of the neck). Immediately afterward the eye can be rotated outward somewhat farther. After the fourth sitting, the images are closer together; the eye can be moved almost to the outer angle. Cured after ten daily sittings.

52. *Personal observation. Paralysis of the right oculo-motor nerve.*—A man, aged seventy years. Occasional diplopia during the past two months. March 20, 1867, quite sudden, complete ptosis of the right eye; since then the eye is constantly closed. April 1st, complete paralysis of all the muscles supplied by right motor-oculi. Galvanic treatment: 12 elements, Ca labile upon the eye, An behind the left ear. April 12th, distinct improvement; can raise the lid half way. Then slow return of motility in the remaining muscles; not entirely cured until May 24th, after twenty-eight sittings.

53. *Personal observation. Paralysis of right trochlearis and insufficiency of right internus.*—A man, aged fifty-two years. Suffering for two weeks (probably in consequence of trauma) from symptoms of paresis of the right superior oblique with insufficiency of the right internus. October 19th, treatment begun in ordinary manner. Immediate effect is very striking; the diplopia disappeared forthwith after the sitting, but reappeared on the following day. With a week's interruption, treatment was continued until November 15th, when patient was discharged cured.

54. *Personal observation. Bilateral paresis of the rectus externus and rectus internus (nuclear paralysis?).*—A boy, aged twelve years. Previously healthy; diplopia for past month, preceded by violent headache for two days. Examination showed vision normal, accommodation not impaired. Both externi and both interni appear very paretic. The other ocular muscles intact; no other symptoms. Galvanic treatment: 8 elements transversely through the temples and mastoid processes; then Ca labile upon the eyelids. After eleven days the muscles were improved, the double images closer together. Severe epistaxis occurred, after which the diplopia disappeared subjectively, and absolute mobility of eyes to the outside much greater; cured a week later.

The methods of treatment of ocular paralyses follow very simply from general principles. In the majority of cases we must employ the galvanic current.

The application must be made first to the site of the lesion, either

through the anterior or posterior parts of the temples or the mastoid processes, according to the supposed location of the morbid process ; the An is first placed upon the paralyzed side, but in the majority of cases it is also advisable to apply the Ca in the same locality. A very practical method of application consists in placing one "medium" electrode upon the closed lids of the affected eye, the other upon the opposite side of the neck and occiput. A feeble current should be employed, with stable application for one-half to one minute in each position. In addition, you may galvanize the cervical sympathetic in the ordinary manner.

But the main feature in the treatment is the direct excitation of the paralyzed muscles by means of the Ca. The An is applied stable to the back of the neck, and the Ca stroked over the closed lids, the points of application corresponding to the muscles to be affected ; the Ca may also be applied stable for a short time. The strength of the current should be such that a distinct burning sensation is felt on the lids, and vigorous contraction of the frontal muscles results upon stroking the temples ; the application to each muscle should last about half a minute. The "small" sponge electrode is most serviceable, but the "medium" electrode may also be employed. The index finger, enclosed in wet linen, may also be used as an electrode, the current being allowed to pass through the entire body in order to control its strength ; this method is more adapted to the faradic current.

The method of application which I have just described is employed also for the faradic current ; the current moderately strong, so that vigorous contractions occur in the orbicularis palpebrarum ; the electrode is applied in the region of the muscle which we desire to irritate. We may come in closer contact with the muscles by employing a wet brush as an electrode, or a fine olive-tipped electrode, introducing it into the conjunctival sac and bringing it as close as possible to the muscular insertions. But this is very annoying to the patient and is insufficient to produce contraction of the ocular muscles. Mydriasis, etc., may also be treated in this manner with two fine brush electrodes, applied opposite one another upon the border of the cornea ; this is best done during narcosis.

In this manner we seek to effect a direct excitation of the paralyzed muscles and motor conducting paths ; this purpose, however, can only be effected in a feeble and imperfect manner, as is evident from the impossibility of thus producing contraction of the muscles.

The results of electrical treatment are very favorable in many cases ; the temporary improvement immediately after treatment is especially evident in many instances, the movements of the eyes becoming more free and the double images approximating more closely. If this persists, recovery ensues rapidly ; but more frequently the improvement disappears and a very long time may elapse before recovery occurs. Finally, there are cases in which galvanic treatment, like every other, proves useless.

2. PARALYSIS OF THE MUSCLES OF MASTICATION

(the motor root of the trigeminus) is extremely rare. It is produced most frequently by intracranial, especially basilar, affections, but may also occur in certain bulbar diseases (Erb); it is very rarely due to diseases of more central portions of the brain (pons, central ganglia, cortex, etc.). Atrophy, loss of faradic excitability, De R are occasionally associated with the paralysis.

Electrical treatment is applied in the same manner as in paralysis of the ocular muscles: first, causal treatment (galvanic current transversely through the anterior or posterior auricular region, or obliquely from the anterior auricular region to the opposite side of the neck, etc.) and then direct excitation of the muscles of mastication with the faradic current, with the *Ca labile* or *Ca closures*, etc., at the motor points (Fig. 29, page 122); the external muscles of mastication (masseter, temporal) are alone accessible. The results depend naturally upon the cause of the disease.

3. PARALYSIS OF THE FACIAL NERVE.

This forms one of the most frequent and favorable objects of electro-therapeutics, and there is scarcely another form of paralysis concerning which we are so well informed.

This is especially true of rheumatic facial paralysis, the most frequent and practically important variety; its symptomatology, electrical relations, and treatment are typical of all other forms of facial paralysis.

Nothing is more readily recognized than a rheumatic facial paralysis, but it is more difficult to determine the site and character of the lesion. The symptomatology renders it positive that the nerve-trunk itself is affected, and probably with greatest frequency in that portion which is situated between the stylo-mastoid foramen and the division of the nerve into the *pes anserinus*; the process may also extend farther into the Fallopian canal, rarely to the geniculate ganglion, and scarcely ever to the base of the skull.

The true character of the affection is still quite obscure, though there is very little doubt that we have to deal with a slight rheumatic neuritis. The exposed situation of the nerve in the position mentioned, the delicacy of the integument at this spot with the absence of protection from a growth of hair, and the tendency to sweating in this region render it explicable that rheumatic influences, affecting one side of the face, should lead so readily to an inflammation of the nerve. On the other hand the narrow calibre of the Fallopian canal causes marked compression of the nerve, when it has undergone slight inflammatory swelling within the canal.

while if the process is confined to the short stretch outside of the Fallo-
pian canal, it will produce slighter injury to the nerve.

Thus, some cases may recover in two to three weeks, in others the
paralysis lasts many months, even a year or more, although the symptoms
were identical at the outset.

Electrical examination enables us to make a very early and accurate
prognosis in individual cases of rheumatic facial paralysis.

In the first group of cases there is no change of electrical excitability,
at most a very slight increase for one or two days at the beginning of the
paralysis. The faradic and galvanic excitability of the nerves and muscles
also remains normal, both quantitatively and qualitatively, during the fur-
ther course of the disease. These cases recover in two or three weeks
(mild form of rheumatic facial paralysis).

In a second group there is no change in the beginning, with the excep-
tion perhaps of a slight increase of irritability, but toward the end of the
first week a slight diminution of the faradic excitability of the nerve and
muscles may be recognized, more distinct in the diminution of the maxi-
mum contraction than in the later occurrence of the minimum contraction;
this does not increase to any notable extent, but during the course of the
second or perhaps the third week, the muscles present the characteristic
changes of the De R and these are often very pronounced. This consti-
tutes the partial De R. The muscles may often be made to contract nor-
mally (short contraction, predominance of Ca Cl C) when the nerve is
stimulated, but react abnormally upon direct excitation (slow contraction,
predominance of An Cl C). This form also presents a relatively favorable
prognosis. The disease recovers in four to six weeks, and rarely continues
eight to ten weeks; the mobility is often restored almost completely be-
fore the changes in the galvanic irritability of the muscles have dis-
appeared. Recovery is complete without the development of subse-
quent contracture and spontaneous spasmodic twitchings in the muscles
(medium form of rheumatic facial paralysis).

Finally, a large number of cases belong to the third group, which at
once presents all the symptoms of complete De R. The prognosis is then
decidedly unfavorable, as these cases always require a very long period
for recovery. The first traces of returning mobility do not begin until
the lapse of two or three months, and several months may further elapse
before recovery is nearly complete; this does not occur usually until
after a certain stiffness of the paralyzed side of the face, contractures,
muscular twitchings, etc., have persisted for some time. This may occupy
from six to fifteen months and traces of the former paralysis may often
remain visible forever to the experienced eye (severe form of rheumatic
facial paralysis).

We are therefore able, at the end of the first week, to give an almost
absolutely certain prognosis with regard to the duration of the disease.

If there is no diminution in the irritability of the nerve at the end of the first week, the disease will last two to three weeks, and four to eight weeks if the irritability is slightly diminished; finally, if there is marked diminution of excitability at this time, it will last at least four to twelve months.

There is no doubt that the variable course of this affection depends upon the varying severity of the lesion, and that the latter depends in great part upon the location of the morbid process. If the latter occurs outside the Fallopian canal, serious compression of the nerve is not possible, the lesion remains slight and rapidly disappears; if it extends into the canal, the interference with conduction becomes complete, not only the motor but also the trophic conduction is entirely prevented and the various grades of De R make their appearance.

The following cases will serve as illustrations of this frequent affection:

55. *Personal observation. Rheumatic facial paralysis (mild form).*—A woman, aged twenty-four years. For six days has had rheumatic paralysis of the right facial nerve. Uvula and velum palati straight, no disturbance of taste or hearing. Electrical irritability of the nerve and muscles entirely normal. Galvanic treatment: first traces of returning mobility on the tenth day; complete recovery on the eighteenth day.

56. *Personal observation. Rheumatic facial paralysis (mild form).*—A porter, aged forty-one years. Acquired right facial paralysis a week ago from exposure; complete paralysis of all facial branches, reflexes abolished, no disturbance of taste, velum palati unaffected. Faradic and galvanic excitability entirely normal. Galvanic treatment. Considerable improvement on eleventh day; recovery almost complete on seventeenth day; discharged cured on twenty-third day (after five sittings).

57. *Personal observation. Rheumatic facial paralysis (moderate form).*—A forester, aged forty-one years. Suffering from left facial paralysis, the result of exposure. Status on the eighteenth day: complete left facial paralysis. Uvula and velum palati normal, no disturbance of taste. Partial De R (slight diminution of irritability of the nerve to both currents, characteristic increase and qualitative change of muscular excitability, viz., An Cl C > Ca Cl C, increased mechanical irritability). Galvanic treatment employed and patient discharged cured on the sixty-fifth day.

58. *Personal observation. Rheumatic facial paralysis (moderate form).*—A student, aged twenty-one years. Has had left rheumatic facial paralysis for four days; all the facial branches paralyzed, uvula and velum palati normal; hearing normal, disturbance of taste on left anterior half of tongue. Electrical excitability still normal. On the seventh day distinct diminution of faradic excitability of nerve-trunk, no trace of De R. On the thirteenth day faradic excitability still more diminished, especially in the mental branches; distinct degeneration reaction in the muscles of the chin; traces of returning mobility in the frontal muscle. At the end of two and a half months mobility in distribution of frontal branch entirely restored, very deficient in muscles upon upper jaw and chin. Taste restored. Partial De R especially distinct in the muscles named. Galvanic treatment again resumed (after intermission of two months) and recovery occurred in four weeks.

59. *Personal observation. Rheumatic facial paralysis (severe form)* — A woman, aged sixty-two years. Seen on second day, after sudden occurrence of right rheumatic facial paralysis. Complete paralysis of all facial branches; uvula and velum normal. Complete De R developed in a typical manner. Galvanic treatment (Ca labile along the nerve and muscles, An behind the ear) begun at once. On the sixty-sixth day, first trace of mobility in frontal muscle. On the one hundred and forty-fifth day, improvement is quite advanced, but slight contracture of the muscles has developed, especially around the angle of the mouth. Very slow progress of recovery. At the end of thirteen months disease is still recognizable by the impaired mobility of the muscles, contracture and spasmodic twitchings.

60. *Personal observation. Rheumatic facial paralysis (severe form)*.— A man, aged thirty-six years. Came under observation five days after the sudden development of right facial paralysis. Complete paralysis of the facial branches, implication of the auricular, disturbance of taste, slight hyperacusis, velum palati normal. Complete De R developed in next two weeks. Galvanic treatment (twice a week). First traces of mobility in frontal muscles two months later; recovery almost complete after the lapse of three additional months; slight contracture persisted.

The first feature of the electrical treatment of rheumatic facial paralysis is the direct treatment of the lesion itself; this is best done by means of transverse conduction of the galvanic current through the auriculo-mastoid fossæ or the petrous portion of the temporal bones, in order to relieve the neuritis; then stabile application of the An (especially in recent cases), followed by longer or shorter application of the Ca; the sitting should last one or two minutes with a current of 6 to 10 elements.

The removal of the obstruction to conduction in the nerve is not so simple, because the current cannot be applied with certainty to the proximal side of the site of lesion. But, fortunately, we have at our disposal an extremely effective reflex arc, which facilitates greatly the production of stimulation on the proximal side of the lesion. The trigeminus is entirely intact, and between it and the facial nerve is a direct reflex connection, which is kept in constant use by innumerable physiological processes. Every vigorous stimulation of the facial branches of the trigeminus must therefore give rise to an active centrifugal excitation in the trunk of the facial nerve. For this reason, peripheral faradization and galvanization of the face may be of decided benefit.

This method will also fulfil the final indication, viz.: the removal of the finer and grosser nutritive disturbances in the paralyzed nerves. This is useful in the mild and moderate forms, but it can by no means prevent the progress of degenerative atrophy in severe cases; however, it may hasten the restoration of the muscles in such cases, and should, therefore, not be omitted.

This peripheral treatment—with the galvanic current—consists in the application of the “medium” An behind the ear of the paralyzed side, and

the "small" *Ca labile* along the muscles and nerve with sufficient vigor. First stroke the plexus anserinus and its chief branches, then the individual muscles; it is advisable to treat the *orbicularis palpebrarum* directly, in order to increase its tonus, by stroking the lids and closing them by gentle pressure with the electrode. The strength of the current should be such that vigorous contractions occur together with a distinct burning sensation above the eyelids (6 to 10 elements are usually sufficient); duration, one to three minutes.

The peripheral faradic treatment is similar in character; in the mild and moderate forms the individual nerve branches and muscles should be directly stimulated; in the severe form no muscular contractions will ensue, and the strength of the current then depends upon the sensations of the patient, which should be quite vivid.

The results of treatment vary greatly according to the severity of the case; you should never expect to be able to convert a severe case into a moderate or mild one.

The severity and average duration of the affection are fixed and cannot be much affected by treatment. However, I believe that in the mild and moderate forms electrical treatment will hasten recovery, and, in severe forms, prevent the incurability of the affection, further complete restoration, and antagonize the development of secondary contractures and spasmodic conditions.

Electro-therapeutics is usually quite powerless against secondary contractures in the face, especially those of long-standing; I have employed, without effect, stable and labile galvanization, faradization of the antagonists, etc. You will be compelled generally to resort to other procedures (mechanical extension, massage, etc.).

The electrical treatment of the other forms of facial paralysis does not require a long explanation. These forms may be produced in various ways, which must give rise to certain modifications of treatment. The causes include inflammations of the parotid gland or erysipelas, traumatism (incised wounds, operations, pressure of the forceps during delivery), lesions of the petrous portion of the temporal bone and the base of the skull (otitis media, caries, fractures of the temporal bone, hemorrhages, tumors, aneurisms at the base of the skull), or an affection of the facial nucleus in the medulla oblongata (in bulbar paralysis, etc.), of the tract of the facial nerve in the brain (in apoplexy, cerebral hemiplegia), and, finally, of the motor centres of the facial in the cerebral cortex (in abscesses, tumors, etc.). The symptomatology of the paralysis, its combination with various other disorders, and the condition of electrical excitability are dependent upon the localization. In pure cerebral paralysis, the electrical excitability is entirely intact; in bulbar paralysis, simple diminution of excitability may be present in the affected facial branches and sometimes partial *De R* can be demonstrated; in basilar and other forms of

peripheral paralysis the electrical excitability may vary: De R (partial or complete) is usually present, sometimes simple diminution, very rarely increase of excitability, and still more rarely the latter remains intact.

There are certain modifications in the electrical treatment of these forms of paralysis, occasioned by the situation of the lesion. The latter must be the chief object of electrical application; this is effected in peripheral traumatic lesions at the spot in question, and in affections of the petrous portion of the temporal bone, the ear, and the base of the skull, in the same manner as in the rheumatic form; in bulbar paralysis, transversely through the mastoid processes, or obliquely from the anterior auricular region to the opposite side of the back of the neck; in true cerebral disease, employ the appropriate methods of application, such as have been described before, together with galvanization of the sympathetic. The peripheral treatment, whether faradic or galvanic, may be the same in all these cases.

4. PARALYSIS OF THE SPINAL ACCESSORY NERVE.

This affection is rare, especially the implication of the external branch of the nerve, which is distributed to the sterno-cleido-mastoid and trapezius muscles. The paralysis of the inner branch, which supplies the larynx, pharyngeal muscles, and a portion of the velum palati will be discussed at a later period.

Paralysis of the sterno-cleido-mastoid and trapezius is readily recognized, but its cause and the exact site of the lesion cannot be determined always with certainty. It may occur with or without atrophy of the muscles, with or without De R. You will have to deal most frequently with a peripheral lesion of the nerve, either within or without the spinal canal, next in frequency with a bulbar lesion; not infrequently it is a part-symptom of progressive muscular atrophy, especially of the "juvenile" form, which has been previously referred to.

The electrical treatment is carried out according to the principles laid down with regard to facial paralysis, modified merely by the situation of the lesion and the affected muscles; causal treatment, therefore, through the mastoid processes, or galvanization of the cervical portion of the spine, etc., then direct peripheral treatment in the well-known positions.

5. PARALYSIS OF THE HYPOGLOSSAL NERVE.

This occurs not infrequently, but is usually a part-symptom of central affections, as in progressive bulbar paralysis, and very commonly in ordinary cerebral hemiplegia, more rarely in cortical lesions. The diagnosis of the site of the lesion can be readily made, in most cases, from the gen-

eral symptomatology. Peripheral paralysis of the hypoglossal nerve may also occur (from injuries, operations, pressure of tumors, cicatrices, etc.), but has no great practical significance.

In purely cerebral paralysis of the hypoglossus, atrophy of the tongue does not ensue, nor is there any change of electrical excitability. But as soon as the nuclei of origin in the medulla oblongata are affected, or the peripheral tract of the hypoglossus involved, atrophy of the tongue is never absent, and diminution of the electrical excitability of the organ and even De R may be observed. Brenner noticed the latter in a case of division and in another of compression of the nerve. I have observed partial De R in progressive bulbar paralysis.

The treatment is applied according to general principles: direct, according to the location of the cerebral lesion; when situated in the medulla oblongata, either transversely through the mastoid processes, or the Ca is applied to the motor point of the hypoglossus (*vide* Fig. 29, page 122) and pressed deeply below the angle of the lower jaw, the An being applied high up in the neck.

In the peripheral treatment by means of the galvanic current the An is also applied to the neck, the Ca in the position just mentioned, either labile or with repeated cathodal closures; or the Ca is applied directly to the tongue, either protruded or lying on the floor of the mouth. It is then advisable to employ an interrupting electrode which is insulated as far as the sponge. In the external application, movements of deglutition are also produced, and these prove beneficial to some of the muscles of the tongue. The same electrode may also be used for the faradic current, with which you may either stimulate the trunk of the nerve in the position referred to, or cause contractions in the tongue directly. The current should always be sufficiently strong to produce distinct contractions.

LECTURE XXIII.

Electro-therapeutics of Individual Forms of Paralysis (Continued)—6. Paralysis of the Neck and Trunk: Pathogenesis; Cases; Methods of Treatment—7. Paralysis of the Upper Limbs: Pathogenesis; Symptomatology; Electro-diagnosis; Cases; Methods of Treatment; Results—8. Paralysis of the Lower Limbs: Pathogenesis and Individual Varieties; Electro-diagnosis; Cases; Methods of Treatment; Results.

6. PARALYSES OF THE NECK AND TRUNK.

UNDER this heading I include the isolated or combined paralyzes of all muscles of the trunk, of the thoracic, back, and abdominal muscles, especially the larger and smaller muscles moving the scapula, the extensors of the neck and back, and finally the most important muscle of inspiration, viz., the diaphragm.

These are not, on the whole, very frequent forms of paralysis; some of them may be entirely isolated, and due to traumatic or inflammatory lesions of the nerves, to compression from diseases of the vertebræ, etc. Usually, however, we have to deal with more complicated cases, with combined paralyzes of various muscles and groups of muscles, as symptoms of central, especially of spinal diseases. These muscles are paralyzed and atrophied with relative frequency in progressive muscular atrophy, especially in the juvenile form, in which the most remarkable combinations of atrophy occur in these parts; in the typical form, on the other hand, they generally do not occur until the later stages, and the paralysis of the diaphragm is then not infrequently of fatal significance; paralysis of the muscles of the back is also not infrequent in so-called pseudo-hypertrophy of the muscles.

Some of these paralyzes are of considerable importance with regard to the patient's ability to work (as paralysis of the serratus, the dorsal extensors, the diaphragm), while others produce insignificant disturbances and deformities, which are quite thoroughly compensated by the vicarious function of intact muscles. It will be impossible to enter upon a more detailed symptomatology in this place.

Nor can much be said with regard to the electrical relations of these paralyzes; with few exceptions (serratus, rhomboids, levator anguli scapulae, diaphragm) a direct examination of the muscles is alone possible, although there are some motor points which may be employed. Occasion-

ally a simple diminution of electrical excitability occurs, in other cases marked degeneration reaction, and at times no change can be found. This depends, as a matter of course, upon the location of the cause of paralysis and requires no further explanation.

61. *Observation by O. Berger. Paralysis of the right serratus magnus, after typhoid fever.*—A soldier, aged twenty-six years. Taken sick with typhoid fever; toward the end of the fourth week sudden violent pains developed in the region of the shoulder, and radiated into the arm and along the axillary space; at the same time a sort of "paralysis" developed in the right arm, which could no longer be raised to the vertical position. The pains gradually subsided. Six months later, an isolated complete paralysis was found in the right serratus magnus muscle. All the other muscles appeared unaffected; no anæsthesia, pressure on brachial plexus not painful. The serratus appears very slightly atrophied; the faradic and galvanic excitability of the muscle and its nerve is moderately diminished. Electrical treatment; galvanic current through the long thoracic nerve to the muscle; local faradization of the muscle; marked improvement developed after a short period of treatment. At the end of two and a half months the arm can be raised readily to an angle of 120° ; the electrical excitability has improved. Complete recovery was not effected, however, by continuance of treatment.

62. *Observation by Duchenne. Paralysis and atrophy of the diaphragm cured by faradization.*—A mechanic, aged twenty-five years. Suffering from progressive muscular atrophy; marked difficulty of respiration, especially in walking and on the slightest exertion. Reversal of the respiratory type occurs upon forced breathing; at each inspiration, the epigastrium and hypochondriac regions are retracted, and protruded during expiration. This symptom, which had lasted two weeks, was attributed to paresis of the diaphragm. Regular faradization of the phrenic nerves relieved the symptoms in a few weeks; respiration became normal, and the patient could return to work.

63. *Personal observation. Progressive muscular atrophy (juvenile form).*—A man, aged forty-four years. Noticed, in his fifteenth year, that the right arm became weak and emaciated, but he was always able to work. For a year past, increasing feebleness of various movements of the upper limbs, and also a diminution in the power of the lower limbs; no pains or paræsthesia. November, 1880, examination showed weakness and atrophy of the muscles of the neck, and trapezii and latissimi dorsi; paralysis and atrophy of both serrati; the lower portions of both pectorals have entirely disappeared. The deltoids are very well developed, the left being decidedly hypertrophic, as are also the supraspinati and infraspinati. Flexors and extensors of arms, especially the right, atrophic and paretic. The muscles of the forearms (with the exception of the supinator longus) and hands entirely normal. The extensors of the back, on both sides of the spine, very atrophic and paretic; corresponding lordosis of the lumbar spine; waddling gait; weakness and wasting of the right gluteal muscles; weakness of both ileo-psoas muscles, especially the right; paralysis and atrophy of right tensor vaginæ femoris; paresis in entire distribution of both peroneal nerves, complete paralysis of tibialis anticus. Electrical excitability of the atrophic muscles markedly diminished; no trace of De R. Galvanic current applied to the back, along the entire

spine ; in addition, vigorous peripheral galvanization of the diseased muscles and their nerves. Unexpected improvement occurred ; after several months' treatment all movements could be performed with more vigor, and the patient is very well satisfied with the result, as he was again able to work steadily. As a matter of course, the old chronic disorders were not relieved.

With regard to the methods of electrical treatment, I may refer you to general principles. Under certain circumstances, however, it may become difficult to treat the lesion itself ; occasionally an application may be made to a neuritic or traumatic lesion of the brachial plexus, or to the spinal cord from the cervical to the lumbar enlargement. But the direct treatment must generally be restricted to the paralyzed and atrophic muscles, and this may be done with the faradic or galvanic current, according to the principles of local faradization. Vigorous currents, large electrodes and great perseverance are requisite in the treatment.

In paralysis of the serratus magnus, it is best to apply the An to the cervical vertebrae, and the Ca to the long thoracic nerve in the supraclavicular fossa (*vide* Fig. 29), in the axilla and along its course across the ribs ; the muscle itself is accessible with difficulty to direct stimulation, most readily when the arm is raised and supported.

In paralysis of the sacrolumbales large electrodes and very strong currents (closure, change of polarity) must be employed, the patient bending backward somewhat in order to render possible a full contraction of the muscle.

In paralysis of the diaphragm, direct stimulation of the muscle will be useless, as the amount of current which can reach it will be scarcely ever sufficient ; it may be attempted by passing the current transversely through the costal region, or from the back to the epigastrium and the other points of origin of the diaphragm. But it will generally be better to apply one pole in the epigastrium or along the insertion of the diaphragm into the ribs and the other pole (Ca) to the phrenic nerve in the neck (*vide* Fig. 29).

Paralysis of the abdominal muscles always requires local stimulation of the muscles at all their motor points ; the An being placed upon the back, the Ca is successively moved over these various points.

7. PARALYSIS OF THE UPPER LIMBS.

Scarcely any part of the body is so often the object of electrical treatment as the upper extremity, and this especially on account of the great frequency and variety of paralyzes in this part. All possible varieties may occur—isolated paralysis of single muscles or of certain groups of muscles, paralysis of one or another nerve or combined paralysis of several of them

up to complete inactivity of the entire limb, with or without atrophy, sensory, vasomotor, or trophic disturbances.

These forms of paralysis are very important because they give rise to important disturbances of function and seriously interfere with the usefulness of the patient. They are also very interesting on account of their manifold etiological relations and their significance as symptoms of an entire series of important central diseases, not less on account of the advanced development of their symptomatology and diagnosis, and the manifold character and results of electro-therapeutic measures.

I will confine myself, however, to a short sketch of these features, since the previous general remarks render detailed consideration unnecessary.

The etiological factors of these paralyzes, which are of prime importance with regard to the choice of the method of application, are very manifold. I will premise that paralysis of the upper limb is a very common feature in the symptomatology of central diseases; it plays a part in every cerebral hemiplegia, and may occur in all possible diseases of the spinal cord, such as acute and chronic anterior poliomyelitis, amyotrophic lateral sclerosis, multiple sclerosis, cervical myelitis and meningitis, etc. Much more frequent and varied are the peripheral paralyzes of the upper limbs. They are produced most frequently by traumatic influences, such as simple pressure and external compression, which very often cause paralysis of individual nerves ("sleep" paralysis, "crutch" paralysis), incised wounds, blows, gunshot wounds, fractures and dislocations, surgical appliances and operations. A series of paralyzes of the upper limb are due to exposure, others to neuritis of certain nerve-branches or of the brachial plexus; a not infrequent cause is inflammation of the joints, especially of the shoulder and elbow, which leads in part to neuritic paralysis, in part to muscular atrophy with corresponding paralysis (especially in the deltoid). Finally toxic paralyzes (particularly lead palsy) are apt to be localized in certain neuro-muscular tracts of the upper limbs.

The symptomatology depends upon the situation, localization and extent of the cause of paralysis; if the circumflex is alone affected, paralysis of the deltoid occurs with its well known effects upon the ability to raise the arm; paralysis of the musculo-cutaneous interferes with flexion of the forearm (from paralysis of the biceps and brachialis internus) though not completely, because the supinator longus, which is a flexor of the forearm, often acts vicariously to an astonishing extent; paralysis of the radial (most frequently the so-called "sleep" paralysis) annihilates the function of all the muscles on the extensor aspect of the forearm (extensors and supinators) in a characteristic and typical manner, and also the function of the triceps when the lesion is situated higher ("crutch" paralysis, dislocation of the shoulder); paralysis of the median interferes with flexion of the wrist and fingers, pronation and the action of the thenar muscles, while paralysis of the ulnar renders

difficult the ulnar flexion of the hand and flexion of the last three fingers, and paralyzes the muscles of the hypothenar eminence, the interossei and the adductor pollicis (impossibility of extending the last two phalanges, *main en griffe*). In all these paralyzes sensory disturbances of the nerve and its sensory distribution may be present and contribute considerably to a more accurate diagnosis.

The electrical examination of paralyzes of the upper limb affords very valuable data in several respects. In the first place the exact site of the lesion may be frequently recognized by the fact that the peripheral portion of the nerve is still excitable while the central part is inexcitable on account of the obstruction to conduction, as for example in compression paralysis of the radial nerve; indeed, the peripheral character of almost all peripheral paralyzes of the arm may be demonstrated in this manner by the ineffectual irritation of the brachial plexus in the supraclavicular fossa, provided that complete De R has not entirely destroyed the irritability of the nerves.

Electrical examination also furnishes you with the usual information concerning the presence or absence of gross nutritive disturbances in the paralyzed nerves and muscles, from the presence or absence of the De R. This informs us concerning the severity of the lesion and not infrequently concerning its cause (for example, in radial paralysis, in which the ordinary compression paralyzes usually present normal excitability, while complete De R generally occurs in lead palsy). All possible grades of De R may be observed, the complete form in severe traumatic or neuritic paralysis, lead palsy, infantile spinal paralysis, the partial form in more mild compression-paralyzes, progressive muscular atrophy and amyotrophic lateral sclerosis, while in very slight compression-paralyzes (for example, in "sleep" paralyzes) and in those whose origin is located in the upper cervical cord or brain the electrical excitability is entirely intact, or, at the most, presents slight diminution, in very rare cases a slight exaggeration.

In addition to those mentioned above, there are a number of forms of combined paralyzes, in which several nerve tracts are affected at the same time or in which the more or less numerous paralyzed muscles belong to various peripheral nerve branches (probably to a certain tract in the roots of the brachial plexus or to a definite spot in the spinal cord). The former includes the paralyzes (often very extensive) following luxations of the shoulder and elbow joints and fractures of the humerus, and the majority of central paralyzes of the arm; the latter embraces many cases of progressive muscular atrophy (especially the juvenile form), advanced cases of lead palsy, certain forms of paralysis after delivery, and the combined "shoulder-arm" paralysis (deltoid, biceps, brachialis internus, supinator longus and infraspinatus) first described by me, and which is usually situated in the roots of the brachial plexus starting from the fifth and sixth cervical nerves (in the region of or above the so-called supra-

clavicular point, *vide* Fig. 29), perhaps also in the corresponding parts of the anterior gray columns of the spinal cord. The remarks previously made concerning symptomatology and electro-diagnosis also apply to these combined paralyses.

I refer you to the histories of cases mentioned in previous lectures (Observations 5, 6, 8-12, 15, cases of paralysis of the upper limb from cerebral diseases; Observation 34, chronic anterior poliomyelitis; Observation 35, progressive muscular atrophy; Observation 37, ulnar paralysis; Observation 38, combined "shoulder arm" paralysis; Observation 39, deltoid paralysis; Observation 40, paralysis following dislocation of the humerus; Observation 41, radial paralysis), and may confine myself, therefore, to the recital of a few instructive cases.

64. *Personal observation. Paralysis of the left musculo-cutaneous nerve.*—A man, aged thirty-seven years. May 29, 1879, upon getting up he noticed numbness on flexor side of left forearm and weakness of the left arm; cause unknown.

June 3d.—The sole disturbance is very marked interference with flexion of left forearm, which is only effected by vigorous contraction of the supinator longus; the biceps and brachialis internus are completely paralyzed; coraco-brachialis normal. Distinct dulness of all varieties of sensation in the forearm in the distribution of the external cutaneous nerve. Electrical examination: Normal contraction of the muscles on the right side may be obtained by irritating the supraclavicular point; on the left side, the deltoid and supinator longus alone contract, the biceps and brachialis internus remaining flaccid. At a later period partial De R occurred in the flexors of the forearm. Galvanic treatment at the supposed site of lesion, then irritation of the supraclavicular point and peripheral galvanization of the muscles. Improvement soon occurred and the patient was discharged cured after eight to ten weeks.

65. *Personal observation. Traumatic paralysis of the left median and musculo-cutaneous nerves.*—A soldier, aged twenty-four years. Wounded August 4 1870; tract of wound from anterior half of left deltoid to immediately underneath the angle of the left scapula. Anæsthesia and paralysis (with severe pains) in entire distribution of left median nerve; also paralysis of biceps and brachialis internus (inner half).

October 8, 1870.—Very marked paresis of all these muscles, diminished sensibility in median distribution to the hand; moderate atrophy of the muscles and great tenderness on pressure. Complete De R in median distribution, partial De R in biceps. Galvanic treatment in supraclavicular region, then Ca labile along the nerves and muscles; immediate improvement of mobility. Fourteenth sitting, sensibility of fingers restored; flexors of forearm act normally; no very great improvement in the median distribution. Patient left after twenty-one sittings.

66. *Personal observation. Paresis of the right ulnar nerve.*—A man, aged thirty-four years. A year ago suffered from similar affection which was relieved by the galvanic current after a few sittings. For three days has had feeling of numbness, anæsthesia and weakness, in right hand. Sensation markedly diminished in distribution of middle cutaneous nerve to forearm and ulnar nerve to hand; mobility impaired in ulnar distribution. Galvanic treatment: An to the ulnar nerve above the elbow, Ca stabile and labile to the skin and muscles. After a short application, sensibility

returns under the An, and on passing it down the forearm sensation gradually returns to all parts which have been touched by it; mobility also appears improved after the sitting. Complete recovery in four days.

67. *Personal observation. Crutch paralysis of the right radial nerve (traumatic paralysis of the sciatic).*—A soldier, aged twenty-five years. Wounded August 4, 1870; gunshot wound of the knee, entered anteriorly next to the patella, emerged in the middle of the thigh posteriorly near the sciatic nerve; complete paralysis of the sciatic with De R.

September 24th.—Patient began to walk a little with crutches, but soon noticed an increasing weakness of the right hand, especially the extensors; at the end of eight to ten days, could no longer hold the crutch.

November 4th.—Complete paralysis of distribution of right radial nerve, including the triceps; paresis of median and ulnar nerves; no notable sensory disturbances. Electrical irritability of paralyzed nerves and muscles intact, but no contractions of the extensors upon the forearm can be obtained from the supraclavicular point. Treatment: An upon the brachial plexus, Ca labile through the nerve and muscles, with closures and changes of polarity.

December 5th.—Complete recovery.

68. *Personal observation. "Sleep" paralysis of the radial nerve.*—A laborer, aged forty-two years. Slept on his arm the night previously; noticed paralysis of hand this morning, with paræsthesiæ in radial distribution to the thumb. Examination shows complete paralysis of radial distribution to forearm; triceps intact. Electrical irritability normal, but no contractions can be obtained from axilla or supraclavicular fossa. Treatment: Ca stabile to site of pressure, then to supraclavicular fossa; Ca also applied labile to nerve and muscles. Recovery at the end of a week.

69. *Personal observation. "Sleep" paralysis of the radial nerve.*—A man, aged twenty-five years. September 10, 1872, acquired a paralysis of the left arm during sleep (lay upon the edge of the bed).

October 11th.—complete paralysis of the nerve still present. The skin of thumb and dorsum of hand feels numb, with diminished sensibility. Electrical irritability intact; no contractions in radial distribution can be secured from the axilla or supraclavicular region, but this can be done readily on right side. Galvanic treatment: immediately afterward patient raises his arm to the horizontal.

October 12th.—Considerable improvement; faradization.

October 24th.—Discharged almost cured; all movements can be executed, though not with full power. Patient returned in a week, and after treatment for another month, normal power was restored.

70. *Personal observation. Traumatic paralysis of the radial nerve.*—March 10, 1881, fracture of arm and forearm. Radial paralysis noted after removal of bandage; marked callus formation in arm. May: radial nerve is exposed, found to be thinned in and below the callus, thickened above. September: complete paralysis of entire radial distribution in forearm; complete De R; diminished sensibility on posterior aspect of forearm. Slight contracture of the flexors. Galvanic treatment to the site of lesion and the muscles from end of September.

October 13th.—Distinct power of motion, though feeble; sensibility improved. Faradic and galvanic excitability of the nerve has returned above the site of lesion; De R still present in the muscles. From this time on improvement was more rapid.

71. *Personal observation. Combined shoulder-arm paralysis (Erb) from*

injury.—A baker, aged thirty-eight years. Fell upon the extended left arm and the left shoulder. Impaired power of moving the arm forthwith, and numbness of shoulder and upper half of arm.

July 20, 1867.—Complete paralysis of left deltoid, biceps, and brachialis internus. Complete De R of paralyzed muscles, especially the deltoid. Galvanic treatment: An to plexus and cervical cord, Ca labile along the paralyzed nerves and muscles. In a few days improvement in flexors of forearm, which slowly progressed; deltoid rapidly atrophied. Patient discharged after twenty-two sittings; biceps and brachialis internus very much improved; deltoid still completely paralyzed. (Six weeks later spontaneous improvement began in this muscle, with final recovery.)

72. *Personal observation. Combined shoulder-arm paralysis from neuritis of the brachial plexus*.—A boy, aged seventeen years. Two months ago affected with paræsthesia in left thumb and index finger; diminished sensation and motion in these fingers; in two weeks, paralysis of shoulder and arm.

December 1, 1866.—Complete paralysis of deltoid, biceps, brachialis internus and supinator longus, probably also supinator brevis; paralysis in distribution of median nerve to forearm and hand. Electrical examination shows partial De R in paralyzed muscles. Galvanic treatment: An stable to the brachial plexus, Ca labile (and with closures) to paralyzed nerves and muscles. After the tenth sitting: flexion of forearm normal; flexors of fingers, thenar muscles, and supination very much improved; the deltoid also begins to act. Complete recovery after thirty sittings.

73. *Personal observation. Traumatic paralysis of the radial, median, and ulnar nerves*.—A soldier, aged thirty-eight years. Wounded August 4, 1870; gunshot fracture of upper third of right arm.

November 4, 1870.—Complete motor and sensory paralysis of right forearm and hand. Complete De R in distribution of radial nerve; faradic and galvanic excitability pretty well retained in ulnar and median distribution. Immediately after the first application of galvanism (An to the neck, Ca labile peripherally, etc.) sensibility returned to a certain extent in the median and ulnar distribution, and slight movements (which were previously impossible) could be performed by the flexors. Rapid improvement in next few days, and (November 7th) feeble movements appeared in radial distribution. The stiffness of the joints interferes somewhat with motion, but improvement made favorable progress.

The method of electrical treatment of these paralyzes depends, in the first place, upon the most exact possible diagnosis of the situation and character of the lesion causing the paralysis; when that is known, the application should be made to the site of the lesion: in cerebral paralysis the applications should be made to the head and sympathetic (*vide Lectures XV. and XVI.*), in spinal paralysis to the cervical cord and sympathetic (*vide Lectures XVIII. and XIX.*); peripheral paralysis (*vide Lectures XX.*) requires treatment of neuritis, traumatic lesions, affections of the shoulder-joint, cicatrices, etc., by the well-known methods. With regard to the frequent compression-paralyzes of the radial nerve, which interfere so much with the use of the hand, I will here make mention of E. Remak's statement that the most favorable results are secured in many

cases by the stable application of the Ca with a current of moderate strength, and these results are often manifested by the occurrence of increased mobility during the passage of the current. I can confirm this statement with regard to some cases, though only of those which are very mild or have already begun to improve (*vide* Observation 68); as a rule, however, I have been unable to detect such an immediate effect.

Direct antiparalytic treatment must next be applied, and this is often very serviceable in peripheral paralyses of the upper extremity. It is not infrequently possible to apply the current to the proximal side of the lesion, and thus cause an effective breach in the obstruction to conduction. It is therefore advisable to attempt this plan in all suitable cases, and to produce a vigorous stimulation of the nerve-trunks in the axilla, or still better, in the supraclavicular fossa. In order to fulfil all the indications involved (direct antiparalytic action, removal of finer and grosser nutritive disturbances in the nerves and muscles), the nerve-trunks and muscles throughout their entire extent should be subjected to vigorous electrical excitation, according to the well-known methods of local faradization (*vide* Figs. 30 and 31); this holds good with regard to central as well as peripheral paralyses. It is difficult to determine whether any influence is produced by reflex actions, though this is not improbable; at all events, in paralysis of mixed nerves, the peripheral stimulation of the nerve-branches and the integument will do something toward relieving the obstruction to sensory conduction, and very probably may also exert a reflex effect upon the motor tracts and the obstruction in them.

It is unnecessary to enter into a detailed consideration of the individual forms of paralysis.

I will state, however, that when contracture of the antagonists is present (as in cerebral hemiplegia, infantile spinal paralysis, etc.), and interferes with the contraction of the paralyzed muscles, it is well to relieve this by electrical means or mechanically, and then to stimulate the paralyzed muscles.

It goes without saying that the results of treatment depend upon the causes of the paralysis. They are most favorable in simple compression-paralysis, not unfavorable in severe traumatic paralyses, very good in those of neuritic origin, much less favorable in spinal and cerebral paralyses.

8. PARALYSES OF THE LOWER EXTREMITY.

In the lower extremities the conditions with regard to paralysis are much simpler than in the upper limbs, although it occurs here very frequently and in manifold combinations, such as isolated paralysis of individual muscles and nerves, combined paralyses up to total paralysis of one and very often of both limbs (paraplegia). In the lower extremities the

paralyses of central origin are of paramount importance, especially the spinal paralyses, while cerebral varieties, despite their frequency (in hemiplegia, etc.), occupy the background because they often improve rapidly, and are not felt so severely by the patient.

Almost all diseases of the spinal cord lead to motor weakness or marked paralysis of the lower limbs (the various forms of myelitis, especially acute and chronic poliomyelitis, sclerosis, acute ascending paralysis, progressive muscular atrophy, compression and concussion, meningitis, etc.); and almost all these forms are very often the object of electro-therapeutic measures.

The long peripheral course of the nerves, within the spinal canal, in the pelvis, and finally along the extremities, gives rise to a great number of possible causes of peripheral paralysis; fractures, dislocations, inflammation and caries of the vertebræ, lesions of the pelvis and pelvic organs, mechanical effects of severe inflammations may give rise to paralysis. In addition, all possible mechanical and traumatic influences, which affect the nerve-trunks in the limbs, inflammatory, exudative, and other processes in the large joints are frequent causes of such paralyses; finally, we must mention neuritic affections of these nerves (rheumatic and neuralgic neuritis, after acute diseases, etc.). I will also mention that the lower limbs are affected by paralysis in the so-called pseudo-hypertrophy of the muscles and in the much rarer true muscular hypertrophy.

It is not my office to enter in detail into a consideration of the symptomatology of these various forms of paralysis. I will merely state that in paralysis of the crural nerve the flexors of the hip-joint (*psaos magnus*, etc.) and the extensors of the leg (*quadriceps*, etc.) are chiefly affected; this also occurs in an isolated manner in *psaos* affections and in acute anterior poliomyelitis; partial paralysis and atrophy of this nerve are also found not infrequently in progressive muscular atrophy, especially the juvenile form. Paralysis of the obturator nerve affects chiefly the movements of adduction of the thigh, and is, on the whole, quite rare. Paralysis of the gluteal nerves affects chiefly the movements of abduction and rotation, then fixation of the pelvis in walking and standing; it is most frequent in progressive muscular atrophy and pseudo-hypertrophy. Paralysis of the sciatic nerve occurs most frequently, either of the entire trunk or its two chief branches; the peroneal nerve, involving the anterior muscles of the leg, or the tibial nerve, involving the muscles of the calf. Almost all spinal paralyses begin in the distribution of this nerve, and its great length and exposed position also give rise to great frequency of peripheral lesions in its course.

Electrical examination is only available to a limited extent; this holds true especially in determining the exact site of the lesion in peripheral paralysis because very large portions of the affected nerves are not accessible to direct electrical excitation, since they are situated within the pel-

vis or spinal canal. Otherwise the same changes of electrical excitability are found in these paralyses as have been described previously, and we may draw similar deductions from them, especially with regard to the severity of the lesion, the secondary trophic disturbances and the prognosis. You must be cautious, however, in making deductions concerning the situation of the lesion, as the electrical examination, as a rule, does not enable us to determine whether the lesion is of peripheral, spinal, or cerebral origin. If De R is present you may, indeed, exclude its cerebral origin, but normal excitability may also be observed in spinal diseases; nor can you positively infer the peripheral character of the lesion from the presence of De R, as you are aware that this occurs also in very many spinal affections. Other symptoms must be taken into consideration in making the differentiation; it should be particularly noted that the presence of De R without any sensory disorder or trophic changes in the integument indicates quite positively the spinal origin of the paralysis. Partial De R is also observed not infrequently in the lower extremities (moderate form of 'chronic poliomyelitis, certain peripheral paralyses, progressive muscular atrophy, etc.); but in true and false muscular hypertrophy and in the juvenile form of progressive muscular atrophy, simple diminution of electrical excitability is always found without qualitative change.

I will report merely a few examples of these paralyses and refer you to the previously reported Observations 5, 6, 7, 11, 18-22, 32-34, 45, and to Observations 82-84, 86-88 which will be described later.

74. *Personal observation. Paresis of the crural nerve (chronic neuritis?)*.—A man, aged thirty-nine years. Suffering about one and a half years from violent pains in the left hip and buttock, extending to the knee; these gradually subsided, and were followed by a feeling of heaviness in the limb with marked weakness during the last few months. A month ago, after exertion, had severe pain in entire left lower limb, especially anterior surface of thigh; the limb has since grown considerably weaker and emaciated.

April, 1869.—Left thigh distinctly atrophied and flabby; weakness of left quadriceps; diminished sensibility on inner, anterior aspect of thigh; electrical excitability slightly diminished. Galvanic treatment: stable currents through the spinal column; then Ca labile along the nerve and muscles and the anæsthetic portion of the integument, the An in the small of the back. End of May; continued marked improvement; the circumference of the left thigh has increased one and one-half centimetres; power of the limb markedly increased; numbness almost disappeared. Treatment discontinued after sixty-five sittings.

75. *Personal observation. Paresis of the right sciatic nerve; hypertrophy of the calf muscles*.—A man aged forty-three years. Has been treated twice for similar affection and rapidly cured by electrical brush; again returns with complaint of weakness in right foot and leg, with coldness and formication of foot and calf.

November, 1873.—Patient drags the right leg; unable to move the

right toes. Distinct paresis of muscles of right calf; some weakness in distribution of peroneal nerve, also in posterior thigh muscles; crural distribution normal. Electrical excitability unchanged. Circumference of right calf two centimetres larger than that of left. Galvanic treatment: 18 elements labile from small of back through the sciatic nerve; immediate improvement. After two more sittings, patient so much relieved that he stops treatment.

76. *Personal observation. Paralysis in the distribution of the right peroneal nerve (neuritis?).*—A woman, aged twenty-six years. Sick since July, 1866; non-appearance of menses, followed by fornication and weakness of right foot; dragging of toes.

May 18, 1867.—Paresis in distribution of right peroneal nerve; complete paralysis in tibialis anticus alone; sensibility diminished upon entire anterior surface of leg and the dorsum of foot. Circumference of right leg one centimetre less than that of left. Electrical examination shows complete De R in tibialis anticus, simple diminution of excitability in other affected muscles. Galvanic treatment: stabile and labile currents through lower part of spine, then Ca labile through the sciatic and peroneal nerves and their muscles.

July 20th (after eighteen sittings).—Mobility almost normal; slight diminution of sensibility still present.

77. *Personal observation. Paralysis of the left peroneal nerve from the cicatrization of a bed-sore.*—A girl, aged nineteen years. During an attack of typhoid fever had severe bed-sore over sacrum, which healed after suppurating for months. It was finally noticed that the left leg was paralyzed; at times, severe pains started from the back, shooting through the limb into the peroneal distribution. The patient came under treatment three months later.

June, 1873.—A large deep cicatrix upon the buttocks, deeper and firmer on the left side. Almost complete paralysis of entire distribution of left peroneal; sensation normal. Circumference of left calf three and a half centimetres less than that of right calf. Complete De R, late stage. Galvanic treatment: 24 elements An and Ca stabile through the cicatrix; then An to the cicatrix, Ca labile through the nerve and muscles.

August 12th.—The patient was discharged; improvement has made distinct, though slow progress. Excitability of peroneal nerve has returned to a slight extent.

78. *Personal observation. Traumatic paralysis of the left peroneal nerve.*—A man, aged thirty-four years. In a railway accident, December 24, 1872, the left leg was contused in the popliteal space in the immediate neighborhood of the head of the fibula; immediate paralysis and anæsthesia of the left leg and foot (not the sole).

January 25, 1873.—Complete paralysis of entire distribution of left peroneal nerve, weakness of posterior tibial distribution. Sensibility somewhat diminished on dorsum of foot, quite normal in leg. Left calf two centimetres smaller than right. Complete De R in peroneal distribution; simple diminution of excitability in tibial distribution. Galvanic treatment: stabile with both poles through the site of contusion, then Ca labile through the muscles. Traces of mobility returned at end of March, first in extensor longus digitorum, then in the peroneal muscles. Improvement made steady progress and patient was discharged cured, July 20th; mobility good, but power not yet entirely normal.

The methods of treatment are essentially the same as in the upper limb. The causal application must be made to various parts, according to the site of the lesion, and special attention must be paid, in this respect, to the treatment of diseases of the spinal cord, articular affections, peripheral nerve lesions, etc., according to the well-known rules. Be especially careful with regard to the proper localization of the current upon the diseased portions of the spinal cord.

The further treatment, with direct application of the current to the paralyzed nerves and muscles, must be made according to general principles; the possibility of vigorous action above the site of lesion sinks into the background, because the plexuses are almost inaccessible to the current. In suitable cases, however, you may attempt to stimulate the nerve-trunks of the cauda equina within the spinal canal by means of very strong currents and large electrodes (Ca Cl and changes of polarity, *vide* page 54); or stimulate the sacral plexus in the rectum, which can readily be done by a rectal electrode, the other being applied upon or next to the sacrum, or upon the point of exit of the sciatic nerve. In all applications to the large nerve-trunks of the lower limbs, especially in the upper portions, it is advisable to employ large electrodes and relatively strong currents. The An should be applied to the lumbar region, the Ca to the nerves and motor points, in such a manner that a large part of the course of the nerve is situated in the track of the most dense portion of the current. The crural nerve may be accurately reached in the groin, the sciatic nerve immediately underneath the gluteus maximus, and the latter nerve may be treated labile in its whole course along the posterior surface of the thigh by stroking it vigorously with the Ca. In the popliteal space, the peroneal and posterior tibial nerves may be stimulated with the greatest facility (*vide* Fig. 33). In cases in which the nutritive condition of the muscles requires special consideration you may also resort to faradic or galvanic excitation of the muscles according to the well-known rules.

Reflex effects are much more available in the lower extremities than in the upper. Numerous reflexes, particularly from the sole and dorsum of the foot, the anterior and inner surface of the thigh, the groin, may be obtained and employed under certain circumstances in the treatment of paralysis (according to the general principles laid down on page 190). It will be rarely necessary to resort to faradic brushing of the integument in the positions referred to above; ordinary faradic or galvanic stimulation of the nerve-trunks and labile excitation of the skin with moist electrodes will suffice for this purpose.

As a matter of course the results of electrical treatment depend chiefly upon the causes of paralysis. The prognosis is very poor in severe spinal diseases, but good results are often obtained in chronic anterior poliomyelitis, in traumatic, neuritic, arthritic, rheumatic, and compression-paralysis.

LECTURE XXIV.

Electro-therapeutics of Individual Forms of Paralysis (conclusion)—9. Paralysis of the Velum Palati and Pharynx; Paralysis of Deglutition: Pathogenesis; Cases; Methods of Treatment—10. Paralysis of the Laryngeal Muscles; Paralysis of the Vocal Cords: Character and Methods of Treatment; Percutaneous and Endolaryngeal Application; Results—11. Paralysis of Respiration: Artificial Respiration; Rhythmical Faradization of the Phrenics—12. Diphtheritic Paralysis: Pathogenesis and Symptoms; Cases: Electrical Treatment; Galvanization of the Heart; Results—13. Lead Palsy and other Toxic Paralyzes: Characteristics of Lead Palsy; Electrical Excitability; Situation and Character of the Disorder; Method of Treatment—14. Muscular Atrophy and Hypertrophy: Purely Muscular Atrophy; Atrophy in Articular Affections; Cases; Treatment; Muscular Hypertrophy; Congenital Myotonia.

9. PARALYSIS OF THE VELUM PALATI AND PHARYNX; PARALYSIS OF DEGLUTITION.

PARALYSIS of the velum palati is characterized by nasal speech, difficulty in the pronunciation of certain letters, disturbance of deglutition and regurgitation of fluids through the nose, and is recognized on inspection by immobility during phonation and abnormal position of the velum palati and uvula, and also by the absence of reflex movements on touching these parts; it may be unilateral or bilateral, confined to individual muscles or diffused over all. It is often a part-symptom of paralysis of the facial nerve (at the base of the skull) or the trigeminus, or a sequela of diphtheria, or a symptom of bulbar paralyzes, occasionally of cerebral hemiplegias.

Paralysis of deglutition, from paresis and paralysis of the pharyngeal constrictors, is sometimes a part-symptom of cerebral paralysis, but is most frequently either a sequela of pharyngeal diphtheria or a symptom of bulbar paralysis. It is characterized by difficulty or impossibility of deglutition, by the fact that food "goes the wrong way," and by the absence of vigorous reflex contractions upon mechanical irritation of the walls of the pharynx.

As a rule, it is not difficult to recognize these disturbances, but it is often difficult or impossible to determine the degree of implication of the individual muscles or nerve-branches.

Nor does electrical examination furnish much information in this regard, since isolated excitation of the individual muscles can be imperfectly performed. In some cases nothing abnormal has been found; in others, simple diminution of excitability (bulbar paralysis); in others De R (for example, in diphtheria, in which it was first observed by Ziemssen). Not many attempts have been made to examine the pharyngeal muscles directly with electricity; on the other hand, the reflex development of movements of deglutition (*vide* page 55) may be difficult or impossible in paralysis of deglutition, so that very strong currents become requisite (in progressive bulbar paralysis).

A few observations may serve as illustrations of the treatment and its results:

79. *Personal observation. Paresis of the velum palati.*—A girl, aged seven years. Had presented symptoms of the disease from early childhood: nasal twang in speaking, and inability to pronounce certain letters, especially *s, c, x*, etc., because the air escaped through the nose, and the *s* sounded very much like *n*. Examination showed slight paresis of the velum palati; while drinking, fluid occasionally escapes through the nose. Child never had diphtheria; is well otherwise. Treatment: galvanic current transversely through the anterior auricular region and longitudinally from the back of the neck to the cheeks and the floor of the mouth; slow improvement. Later, direct faradization of the velum palati, and systematic exercise in the pronunciation of the *s* sound. Cured in about fifty sittings.

80. *Observation by M. Rosenthal. Diphtheritic paralysis of the velum palati, the tensor of the choroid, and the sphincter of the pupil.*—A girl, aged twenty-two years. Had diphtheria; suffering from difficulty in deglutition, frequent regurgitation of fluids; indistinct, nasal speech; paresis of the right half of the velum palati. Paresis of accommodation; right pupil dilated, and reacts poorly. Velum palati and pharyngeal reflexes markedly diminished; electrical examination showed De R. Local galvanic treatment of the velum and the production of movements of deglutition cured the nasal speech and the disturbances of deglutition within a week.

81. *Personal observation. Diphtheritic paralysis.*—A man, aged twenty-five years. Had diphtheria from June 29 to July 12, 1867. A few days later, renewed difficulty in deglutition, but without pain; regurgitation of fluids through the nose. Some weakness and tremor in the limbs; diminished power of vision; difficult, slightly nasal speech.

July 18th.—Mobility of velum during phonation tolerably good, but slightly defective on the right side; sensibility very markedly diminished; reflex excitability entirely absent. Distinct diminution of faradic and galvanic excitability of the muscles of the velum palati. In drinking, fluids enter the nose, deglutition disturbed. Sight not so good, especially for distance; pupils differ slightly, and react slowly. Galvanic treatment transversely through the cheeks, cervical sympathetic, and direct application of the Ca to the velum palati.

September 2d (after eighteen sittings).—Patient discharged in a tolerably good condition.

Also see Observations 16 and 17 (difficulty of deglutition as a result of bulbar diseases).

The method of treatment of these paralyses should be selected with regard to the causal lesion, *i.e.*, the applications suitable to bulbar and cerebral diseases, to paralysis of the facial nerve, etc.; in diphtheritic paralyses the stable galvanic current should be passed, for a few minutes, transversely through the region of the velum palati and pharynx (transversely through the cheeks in front of the ear or through the auriculo-mastoid fossæ).

In paralysis of the velum palati we may also employ direct faradization or galvanization, by which contraction of the paralyzed muscles will be produced in a direct as well as a reflex manner. The electrode should be catheter-shaped, insulated to the tip, which should be small and round, and covered with fine sponge or chamois; it is well to have an interrupting handle (Fig. 39). The tip of the electrode is applied to the various parts, the mouth being kept wide open, and deep respirations taken through the mouth; the current should be sufficiently strong to produce distinct contractions in the tongue or the muscles of the lips, if they cannot be produced in the velum itself. The anode is applied to the neck, the duration of the application being one to three minutes.

In paralysis of deglutition the same electrode may be employed to produce direct and reflex contractions of the pharyngeal muscles. But this method is somewhat inconvenient, and it is therefore better to employ the method, previously described (page 55), of producing reflex movements of deglutition from the neck. Stronger currents are required than in healthy individuals, and the strength should therefore be increased until Ca Cl or labile application of the Ca is followed by a distinctly visible or audible movement of deglutition. About ten of these movements should be produced at each sitting. As the muscles are easily exhausted in bulbar paralysis, it is advisable, in this affection, to allow an interval of a few seconds to elapse between the individual acts of deglutition.

The results of treatment depend mainly upon the primary cause of the disease; they are, at the most, palliative in bulbar paralyses, but so much more brilliant in other forms, especially diphtheritic paralyses.

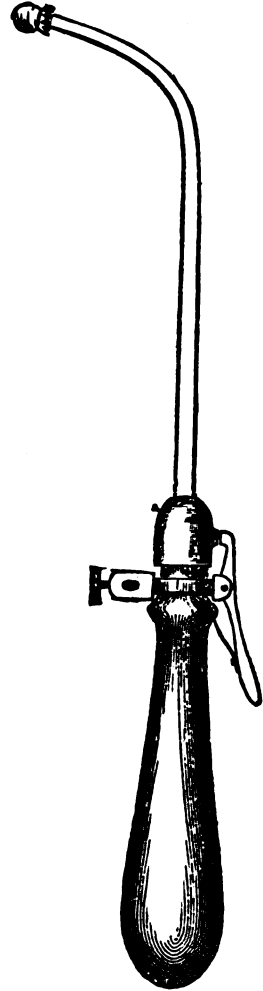

FIG. 39.—Pharyngeal and laryngeal electrode, insulated to the tip: with an interrupting handle.

10. PARALYSIS OF THE LARYNGEAL MUSCLES; PARALYSIS OF THE VOCAL CORDS; PARALYTIC APHONIA AND DYSPHONIA.

More recent studies in laryngology have disclosed the great frequency of paralytic conditions in the laryngeal muscles, which may be either isolated or variously combined.

As a matter of course, the situation of the cause of paralysis is of prime importance with regard to the therapeutic measures—whether in the laryngeal muscles or the most adjacent motor nerve branches (in catarrh, ulceration, new formations, cold, over-exertion); or in the laryngeal nerves, which may be affected in various ways (diphtheria, neuritis, compression by tumors, scrofulous growths, aneurisms, injuries, operations, cicatrices, etc.); or in the trunk and roots of the pneumogastric or spinal accessory (diseases of the vertebræ, tumors at the base of the skull, or in the neck); or, finally, in the central organ itself (bulbar paralysis, hemorrhage into the medulla oblongata, pons varolii, or other parts of the brain, etc.). In some cases, especially in hysterical paralyses, in the rare toxic and intermittent paralyses of the vocal cords, we are entirely in the dark with regard to the site of the lesion.

With respect to the symptomatology, I will state that lesion of the superior laryngeal nerve causes paralysis of the muscles of the epiglottis, insufficient closure of the glottis, paralysis of the crico-thyroid muscle, and anæsthesia of the upper half of the larynx, while a lesion of the inferior laryngeal nerve causes paralysis of all the other laryngeal muscles, and anæsthesia of the lower half of the larynx. This paralysis may be unilateral or bilateral, involving the entire nerve or individual nerves or muscles. Most frequent and important is the unilateral total paralysis of the recurrent laryngeal and, among the isolated muscular paralyses, bilateral paralysis of the arytenoideus posticus, and the very frequent paralysis of the internal thyro-arytenoid muscles, the muscles proper of the vocal cords. Further details may be found in the text-books on laryngology.

Electrical examination of the laryngeal muscles and nerves is not practicable in the majority of cases. Ziemssen states that he has succeeded in testing the electrical excitability in very rare cases, and that he has found normal as well as diminished excitability, and also the De R.

The first point of application in the treatment will depend upon the site of the lesion (transversely through the mastoid processes, through the brain, cervical cord, etc., application of one or both poles upon sites of compression, cicatrices, neuritis, etc., in the peripheral course of the nerves). But this is usually insufficient, especially since, in many cases, we are entirely in the dark with regard to the real situation of the lesion. It is then proper to apply the direct antiparalytic effect of the electrical current to the entire nervous and muscular apparatus of the larynx.

I may recommend percutaneous excitation of the larynx and all its nerves as a method which should be tried in all cases, either with the galvanic or faradic current. In employing the former, the An is placed high up in the neck (in order to be as near as possible to the origin of the pneumogastric and spinal accessory nerves) while the Ca ("small" or "medium" electrode) is stroked labile from the angle of the lower jaw along the larynx and trachea and in close proximity to them, or repeated cathodal closures may be made over all these various parts, both laterally and anteriorly; this is done from one to two minutes on both sides. The pneumogastric, inferior, and superior laryngeal nerves are thus brought within the range of the densest part of the current. If you desire further to stimulate the larynx vigorously, apply "medium" electrodes on each lateral surface and make repeated closures and changes of polarity. From eight to twelve elements will usually be entirely sufficient for this purpose.

With the faradic current the same method of application is employed, the An in the neck, the Ca ("small" or "fine" electrode) at the angle of the lower jaw, at the side of the larynx below the corner of the hyoid bone (superior laryngeal nerve), then pressed deeply along the side of the trachea more inferiorly (inferior laryngeal nerve), finally upon the larynx itself and transversely through it with very strong currents.

There is no doubt that vigorous stimulation of the nerves is possible in this manner.

But if this method does not produce the desired result, you may employ endolaryngeal or more properly endopharyngeal electrization. The previously mentioned laryngeal electrode is used, or one of Ziemssen's double electrodes which admits the introduction of both poles into the pharynx. The strength of the current should be such that distinct contractions are produced in the frontal muscle by faradic or galvanic excitation of its nerve. In unipolar excitation the indifferent electrode is placed upon the back of the neck. The circuit is not closed until the electrode is placed in the required position; its action must usually be restricted to a few seconds in each position.

The following are the chief motor points: superior laryngeal nerve—electrode in the pyriform sinus, pressed somewhat against its anterior wall by raising the handle; transverse arytenoid muscle—electrode upon the posterior surface of the arytenoid cartilages; lateral crico-arytenoid muscle—deep in the pyriform sinus posteriorly and inferiorly; external and internal thyro-arytenoid muscles—same as before, but the tip of the electrode pressed downward, inward, and forward; posterior crico-arytenoid muscle—electrode upon the posterior surface of the arytenoid cartilage and laterally behind the cricoid cartilage; thyro-epiglottic and aryepiglottic muscles—upon the lateral parts of the base of the epiglottis.

This form of treatment meets in practice with the greatest difficulties. Great skill and experience are requisite before treatment can be begun

and each application is followed by gagging, vomiting, temporary aphonia, hoarseness, pain in the neck, etc., so that this plan should only be adopted if the percutaneous method has failed.

Whether the admirable results obtained by Moritz Meyer in hysterical and other forms of vocal cord paralysis by the application of the faradic moxa (vigorous stimulation with a stationary brush) are secured in a reflex manner alone, can not be determined with certainty, since he applies the brush to the integument covering the larynx itself and in this manner the current may enter the organ. Meyer has seen frequent recoveries after one sitting.

The therapeutic results in these paralyzes are usually most striking in so-called hysterical aphonia—the voice is often restored in a few minutes, after it had been extinguished for weeks or months. As a rule, however, the recovery is not persistent. In catarrhal and rheumatic paralyzes, and in those forms due to over-exertion, the prognosis is also very good, especially in those cases in which true paralysis is not present but merely “atony of the vocal cords” (Gerhardt). In the remaining forms the result depends upon the character and severity of the lesion.

11. RESPIRATORY PARALYSES ; ASPHYXIA ; ARTIFICIAL RESPIRATION.

For the sake of completeness I will refer to certain cases of paralysis of the respiratory function, which are due, in great part, to inexcitability of the respiratory centres and are known under the terms trance and asphyxia. The electrical current is sometimes serviceable under such conditions.

I do not refer to the possible effects of the current upon the centres themselves, but rather to the production of artificial respiration, by means of which life may be prolonged until the respiratory centres again resume their independent automatic function and respiration occurs spontaneously. This can be done very readily and continued for a long time without any injurious effects.

Artificial respiration may be effected by rhythmical faradization of the phrenic nerves and other nerves in their vicinity ; as in asphyxia from coal gas, illuminating gas, chloroform or opium, also in profound intoxication, in the trance of drunken and frozen individuals, or of the new-born.

I have previously (page 124) given a short description of the method of application ; I will add that the An should not be placed too low upon the abdomen and should be as large as possible, in order that the inspiratory descent of the diaphragm be not interfered with by the contraction of the abdominal muscles. If you have stimulated the parts for some time and the respirations occur regularly, you should allow an interval to elapse in order to observe whether respirations will not occur spontaneously ; if this

is not the case, artificial respiration should be performed again, and in this manner it may be continued for a number of hours, even for a day or more.

Whether it is not well to alternate galvanic excitation occasionally with the faradic, or to attempt to increase the excitability of the respiratory centres by the occasional passage of a vigorous galvanic current through the cervical cord and medulla oblongata, I will leave undecided, as I have had no personal experience in these conditions.

12. DIPHTHERITIC PARALYSIS.

As the result of diphtheria, either of the pharynx or of other parts of the body, paralyse occur not infrequently; these may be located in various portions of the body and are characterized in a very striking manner by the peculiarity of their localization and the consequent combination of paralyse. They generally begin one or more weeks after the cessation of the diphtheritic process and gradually advance, sometimes even to a fatal termination.

The earliest and most constant affection is that of the velum palati and pharyngeal structures, and is evidenced by the nasal speech, disturbance of deglutition, regurgitation through the nose, defective closure of the larynx, and anæsthesia of the parts with absence of reflex action. Paresis and paralysis of the external and internal ocular muscles (mydriasis, paralysis of accommodation) are not infrequent; also disturbances of the heart's action, strikingly slow or accelerated pulse, cardiac weakness progressing to cardiac failure; furthermore, paresis and paralysis of all possible muscles of the trunk and limbs, with or without sensory disturbance, not infrequently with atrophy and various anomalies of electrical excitability, and occasionally weakness of the sphincters; finally, a form of ataxia which reproduces more or less completely the symptomatology of *tabes dorsalis* (anæsthesia, paræsthesia, absence of tendon reflexes, etc.) but is usually accompanied with distinct paresis, chiefly in the lower limbs.

A series of recent anatomical investigations have given us information with regard to the character and localization of these varied paralytic symptoms; they include hemorrhages, inflammations, and degenerations in all possible parts of the central as well as peripheral nervous system (interstitial and parenchymatous neuritis in the peripheral nerves and spinal nerve roots, meningitic and myelitic changes, especially anterior poliomyelitis, hemorrhages into the brain, spinal cord, and peripheral nerves, etc.)—processes which take a favorable or unfavorable course according to their localization and intensity.

Electrical examination also affords correspondingly variable results: the excitability of the paralyzed nerves and muscles is often found un-

changed, sometimes simply diminished, and not infrequently De R is present. The latter has been observed most frequently in the paralyzed palatal muscles but may also be present in diphtheritic paralyzes of the face and extremities. I will now furnish a few illustrations (*vide* also Observations 80 and 81).

82. *Personal observation. Diphtheritic paralysis; ataxia.*—A student, aged twenty-two years, had diphtheria in August, 1879; a few weeks later, difficulty in deglutition, then weakness and uncertainty of the limbs, paræsthesia and anaesthesia of the hands, slow action of the heart. End of October, 1879; difficulty in deglutition from paresis of the muscles of the velum palati; pupils tolerably wide, with fair reaction, slight insufficiency of the internal recti; slow action of the heart, pulse sixty; distinct ataxia of the arms, numbness and anaesthesia of the hands; a somewhat uncertain gait, slight ataxia and distinct weakness in the peroneal distribution; while standing can not elevate the tips of the toes; electrical excitability distinctly diminished; sensibility of the legs good, cutaneous reflexes normal, patellar tendon reflexes normal. Galvanic treatment of sympathetic, spinal cord, and peripheral nerves and muscles with very good results, and patient had quite recovered at beginning of December, 1879; walks for hours without difficulty, no weakness in peroneal distribution; patellar tendon reflexes vigorous.

83. *Personal observation. Diphtheritic paralysis; ataxia.*—A girl, aged nine years. Had severe diphtheria in beginning of October, 1876. End of October, paresis of accommodation, insufficiency of the internal recti, pupils normal; paralysis of the velum palati from which no reflex action can be obtained. Galvanic applications transversely through the mastoid processes and from the neck to the eyes. Insufficiency of internal recti almost disappeared by November 7th. Feebleness and uncertainty of the legs now developed, with continually increasing ataxia of all the limbs and paræsthesia; entire absence of patellar tendon reflexes. Despite galvanization of the spine and the sympathetic, the disease made further progress and distinct motor paresis made its appearance, chiefly in the upper limbs but also in the left facial nerve and in the legs; no diminution of sensibility. At the end of November, 1876, the disease reached its acme and then began to improve slowly; the mobility of the velum palati first returned, then the gait improved and the ataxia of the legs disappeared; finally the ataxia of the upper limbs also diminished.

February 1, 1877.—The patient was discharged almost entirely well, but the tendon reflexes were still absent and did not return until four weeks later. Complete recovery.

84. *Observation by R. Schulz. Diphtheritic paralysis; ataxia.*—A boy, aged eighteen years. Had diphtheria during Easter, 1877. Two weeks after recovery he observed a disturbance of vision, nasal speech, and difficulty in deglutition; then increasing weakness in the arms and legs, numbness of the soles of the feet.

Middle of July, 1877.—Pupils normal, vision poor for remote and near objects, paresis of the right internal rectus; speech very nasal and stut-tering. Paralysis of the velum palati; distinct paresis of the limbs, especially on the right side; cutaneous and muscular sensibility intact; distinct but slight ataxia of the arms and legs, absence of the patellar tendon reflexes. The large nerve-trunks and the sympathetic are tender on pres-

ure. Electrical examination shows moderate diminution in the individual nerve-trunks, but no De R. Galvanic treatment transversely through the mastoid processes, from the neck to the eyes; galvanization of the spine, direct treatment of the limbs and velum palati with the Ca labile. Paresis of accommodation improved after six sittings, and paralysis of internal rectus and of the velum palati completely relieved after twenty sittings; paresis and ataxia of the limbs relieved in a few further sittings. The patellar reflexes were still absent when the patient was discharged.

85. *Personal observation. Diphtheritic paralysis.*—A girl, aged twenty-two years. Had diphtheria of the pharynx seven weeks previously, soon followed by distinct weakness of the voice, which constantly increased; then difficulty of deglutition with regurgitation of fluids through the nose. For past month, feeble vision, especially for near objects. For the past week, formication in hands and feet. Status: nasal speech; very feeble, somewhat hoarse voice, paresis of left vocal cord; paresis of accommodation, slow pupillary movements; marked paresis of left half of velum palati, less of the right; anæsthesia of these parts with loss of reflex action. No objective disturbance of motion or sensation in the limbs. Electrical examination showed marked De R in the velum palati. Galvanic treatment transversely through the mastoid processes, cervical sympathetic, and spinal cord; direct treatment of the velum palati with the Ca labile. After ten sittings, velum palati very much better, sight somewhat improved. Very slow progress of improvement, so that patient was not discharged in a satisfactory condition until after forty daily sittings. At a later period, complete recovery ensued.

The method of electrical treatment of diphtheritic paralyses presents no peculiarity, but a certain manifold character on account of the numerous localizations with which we have to deal. According to general principles, the site of the lesion must first be determined—whether in the muscles and peripheral nerves, in the roots of the spinal nerves, or in the spinal cord and brain—and the choice of the method of application determined accordingly. In other respects the direct treatment of paralysis of the ocular muscles, of deglutition, the diaphragm and the extremities should be made in exactly the same manner as I have previously described.

In the treatment of weakness of the heart—which, as it seems, may be effected either through the excitomotor paths or the pneumogastric nerve—electricity may also be employed provisionally. Ziemssen found in a patient in whom the anterior wall of the thorax had been removed by an operation and a large part of the heart exposed (covered by the integument alone) that it was possible by means of strong galvanic currents to exercise a direct influence upon the vigor and form of the contractions, and also upon the frequency and rhythm of the heart-beats, *i.e.*, a direct stimulating action upon the motor ganglionic apparatus of the heart. He found that regular and frequent interruptions of strong currents increased the normal frequency of the beats, and also that such an increase could be produced by the action of a strong, uninterrupted current upon certain parts of the surface of the ventricles. On the other hand a retardation of

the heart's action could not be secured with the same certainty and regularity. Similar results can also be obtained when the thoracic walls are intact. The method is : the use of large electrodes, one applied to the cardiac region, the other to the dorsal vertebræ, and then a current of great intensity applied with frequent changes of polarity (seventy to eighty per minute).

In diphtheritic heart failure we may also recommend galvanization of the cervical cord and the medulla oblongata and irritation of the pneumogastric and sympathetic in the neck in a manner similar to that described in the treatment of the larynx (page 223).

The results of electrical treatment in diphtheritic paralysis are, on the whole, very favorable, but sometimes we are unable, despite every effort, to prevent the progress of the paralysis and the fatal termination. Under all circumstances, however, we must expect treatment to be continued for weeks, and often for months, before recovery occurs.

Similar principles govern the treatment of other paralyzes after acute diseases (typhoid fever, cholera, dysentery, acute exanthemata, especially small-pox, puerperal fever, intermittent fever, etc.). In these forms, also, we have to deal with a varied pathogenesis and localization (peripheral, spinal, or cerebral), with severe or slight lesions and all their consequences and symptoms. The electrical treatment depends upon the circumstances surrounding each case.

13. LEAD PALSY AND OTHER TOXIC PARALYSES.

The electro-therapeutist is brought in contact very frequently with paralyzes due to chronic lead poisoning and these are very interesting in many respects. As they interfere greatly with the patient's usefulness, they present no slight practical importance.

As a rule, paralysis is not one of the early manifestations of lead poisoning ; it is usually preceded by other symptoms, especially repeated attacks of colic. At all events the patients must have been subjected for a long time to the deleterious action of the lead.

Lead palsy occurs most frequently in a perfectly distinct and typical form as extensor paralysis of one or both forearms, the extensor communis digitorum being first affected, then the extensors of the wrist, the long muscles of the thumb, etc., while the supinators—and this distinguishes it from the majority of radial paralyzes—escape, the supinator brevis for a long time, the supinator longus permanently, as a rule ; the triceps always remains intact.

The development of the paralysis generally occurs very gradually, spreading from one bundle of the extensor digitorum to the other muscles ; distinct atrophy is soon noticeable, together with constant De R,

though in a somewhat modified form, corresponding to the peculiar manner of development of the paralysis. Sensibility always remains entirely intact. The affection usually spreads to both arms in rapid succession.

This is the ordinary and very characteristic history, but other localizations may occur occasionally. Thus E. Remak has found that the often-mentioned group of muscles (deltoid, flexors of the forearm, supinators, infraspinatus) are occasionally implicated to a predominant extent (arm type) so that my "combined shoulder-arm paralysis" may also be produced by lead poisoning. It is found not infrequently that other muscles are also affected, that it spreads to the small muscles of the hand in the median distribution, to the ulnar distribution, the deltoid, etc., and this may lead finally to general lead paralysis, in which the dorsal muscles, diaphragm, lower limbs (the latter not infrequently in a typical manner, with atrophy and De R) are implicated.

Electrical examination shows that De R is a constant phenomenon in lead palsy. Its development keeps pace with the paralysis; if the latter occurs rapidly, complete De R will be developed; if it occurs slowly, the stage of increased galvanic excitability falls into the background, and the characteristic qualitative anomalies alone remain distinct (slow contraction, An Cl C > Ca Cl C, increased mechanical excitability). Lead paralysis has also presented those remarkable instances of isolated galvanic De R in muscles which are not paralyzed or whose motor power is scarcely at all interfered with, apart from the fact that partial De R is occasionally presented. The long continuance of lead palsy and the not infrequent relapses, may complicate the conditions of electrical excitability in a marked degree.

The De R does not always affect all the muscles implicated in lead palsy; many escape and present either a simple, moderate diminution of electrical excitability or no change whatever.

This fact is decisive with regard to the prognosis, as the muscles which do not present the De R usually return to the normal in a short period, while the restoration of the others ordinarily occupies a very long time. The existence of the De R enables us to draw a positive conclusion concerning the presence of degenerative atrophy, and, at the same time, decidedly favors the theory of a neurotic as opposed to a myopathic origin, and, together with the complete integrity of sensibility, points to a spinal origin of the paralysis (at least in the anterior roots of the nerves).

Nevertheless, despite numerous recent investigations, the question with regard to the nature and localization of lead palsy is still unsettled. It appears, indeed, to be positively determined that it is not situated primarily in the muscles but is of neurotic origin; but whether the primary lesion must be sought in the peripheral nerves (and in their motor fibres alone) or in the anterior gray columns of the spinal cord has not been definitely ascertained. The more recent observations, which have shown a paren-

chymatous degeneration of the peripheral nerves and negative appearances in the spinal cord, favor the view of a peripheral lesion. Nevertheless I can not regard it as positively proven that the spinal cord is not primarily diseased. What can be proven by the negative results of examination with our present defective microscopical methods? *Gross* lesions can not be looked for in a toxic process which usually recovers in a short time, and the *function* of the anterior gray columns and their ganglion cells may be very markedly disturbed, although no change can be demonstrated microscopically! And this disturbed function may produce degenerative atrophy of the peripheral nerves as readily as a primary affection of these tracts.

The weight of clinical evidence appears to me so predominant that I still adhere, for the present, to the theory of the spinal origin of lead paralysis, *i.e.*, to the assumption of a primary change in the anterior gray columns.

Electrical treatment must be directed first to the site of the lesion; in the present unsettled state of the question, I think it well, for two reasons, to treat the cervical enlargement of the cord.

In the first place, because I regard this as the most probable site of the lesion, and, in the second place, because I assume that an application of electricity to the trophic centres in this region may not be devoid of favorable action upon the degeneration of the peripheral nerves (and muscles). First apply a broad ("large") electrode, which covers the entire cervical enlargement, upon the lower cervical and upper dorsal vertebræ, the other electrode upon the sternum, and then permit the stable action of a vigorous current, first the An, then the Ca, for one or two minutes. The form of galvanization of the sympathetic recommended by the elder Remak may also be employed, though it probably acts in consequence of the simultaneous effect upon the cervical cord. Then apply the ordinary methods of peripheral treatment to the radial distribution (or any other neuro-muscular tracts which may be affected), the An remaining upon the cervical enlargement. A few minutes' vigorous labile excitation are sufficient (if the excitability of the muscles is very much reduced, the direct application of both electrodes upon the muscles and changes of polarity may become necessary).

As a matter of course the galvanic current is mainly indicated on account of the degenerative atrophy, but the ripe experience of Duchenne, Moritz Meyer, and others proves that the faradic current is not useless; in all probability, it acts chiefly in a reflex manner.

The results of treatment are usually very satisfactory, but we must persevere for many weeks and months. The majority of cases recover, but many old cases, especially those in which the paralysis is generalized, remain incurable.

Other toxic paralyzes very rarely come under treatment; they have

been observed as the result of copper, mercury, zinc, most frequently of chronic arsenic poisoning. Arsenic paralysis occurs as a more or less diffuse, sometimes generalized paralysis of the limbs, with rapidly progressive atrophy and simple diminution of electrical excitability without De R (Seeligmueller). Its electrical treatment follows general principles.

14. MUSCULAR ATROPHY AND HYPERTROPHY.

It now remains for me to say a few words with regard to the electrical treatment of various forms of muscular atrophy and hypertrophy.

I have spoken, with sufficient detail, of those varieties which are part-symptoms and sequelæ of different peripheral and central paralyzes, and their treatment is pursued according to the general principles laid down on page 192. This forms part of the treatment of poliomyelitis, amyotrophic lateral sclerosis, progressive muscular atrophy, bulbar paralysis, peripheral, rheumatic, traumatic, neuritic paralyzes, lead palsy, etc.

But there are other, so to speak idiopathic or pure muscular atrophies; among these I include those produced by disuse, prolonged rest in bed and inaction, pressure of bandages, ankylosis of the joints, etc., and perhaps a part of those included under the general head of progressive muscular atrophy, especially, the "juvenile form," belong in this category, but particularly those extremely frequent cases of muscular atrophy which follow acute and chronic inflammations of the joints. Their pathogenesis is by no means clear; in a very small fraction of the cases we have to deal with a myositis which has spread from the articular inflammation; in individual cases, perhaps with a neuritis which has led to paralysis of the affected muscles and secondary atrophy. But as a rule nothing of this sort can be demonstrated, and a rapidly progressive simple atrophy occurs with corresponding weakness and paresis of the muscles, which may perhaps be attributed to reflex spinal nutrition-inhibiting influences starting from the articular irritation.

These forms of muscular atrophy are especially frequent and important in diseases of the shoulder and knee-joints, and they then affect mainly the deltoid and quadriceps, more rarely the peroneal distribution; in hip-joint affections I have also observed this on various occasions in the muscles of the hip, buttocks, and thighs. The atrophy may be very pronounced, with more or less marked paresis, perhaps finally paralysis, and is associated occasionally with pain.

It is a characteristic feature that De R is never present in such cases (unless a neuritic paralysis happens to be present), but that the electrical excitability merely shows a simple, more or less marked diminution, but never any qualitative changes. This form of atrophy is thus sufficiently distinguished from neurotic, degenerative atrophy.

86. *Personal observation. Paralysis and atrophy of the quadriceps in consequence of inflammation of the knee-joint.*—A woman, aged twenty-five years. Had a violent and very obstinate inflammation of the knee-joint a year ago; free from pain only during last month; has since noticed that the leg is heavy and immovable, and cannot be advanced properly in walking. Status: right knee-joint somewhat thickened but painless, movements free. Complete paralysis of anterior muscles of thigh; the leg cannot be moved out of the vertical position, nor the limb bent at the hip. Considerable atrophy of the muscles; electrical excitability simply diminished without qualitative change. Sciatic distribution normal. Galvanic treatment directly to the muscles with changes of polarity; one electrode in the groin. Immediately thereafter the leg could be extended to an angle of 45° . After the fourth sitting the leg could be raised almost to the horizontal; electrical excitability considerably improved. After the sixteenth sitting, recovery almost complete; walking only interfered with by the enlargement of the knee.

87. *Observation by Benedikt. Paralysis and atrophy of the quadriceps in consequence of gonitis.*—A girl, aged fourteen years. Had inflammation of the knee-joint three years ago; the secondary flexion contracture was relieved by forced extension. Complete atrophy and paralysis of the quadriceps were then found; electrical inexcitability. Local galvanization and faradization; complete restoration of the muscles after treatment for a number of months.

88. *Observation by Le Fort (Vallat). Traumatic hydrarthrosis of the knee; atrophy of the quadriceps.*—A man, aged thirty-five years. Had marked swelling of the knee and difficulty in walking as the result of a fall (March, 1874). Usual treatment: counter-irritation, tight bandage, etc. The effusion disappeared, but the difficulty in walking persisted. July, 1874, marked atrophy was found in the anterior thigh muscles, which appeared to be entirely powerless. Treatment; daily faradization of the atrophic muscles for a few minutes; application, every night, of a constant galvanic current, An in the groin, Ca on the calf. Marked improvement in two weeks, complete recovery in a month.

The method of treatment of these simple atrophies is essentially the same as that of neurotic atrophy; an attempt is made, by means of regular galvanic and faradic stimulation of the muscles, to improve their nutrition, restore their volume and increase their power. Care must be taken not to employ, at the outset, too strong currents or too prolonged a period of application. It is also advisable to stimulate the nutrition of the muscles by excitation of the nerve-trunks and perhaps also of the trophic central apparatus.

The results of treatment depend mainly upon the cause of the atrophy, but, as a rule, persistent and long-continued treatment will be necessary.

The pathogenesis of pseudo-hypertrophy and true hypertrophy of the muscles is still very uncertain: the assumption that we have to deal, in these affections, with neurotic or spinal disorders remains unproven. Electrical treatment may be adopted according to your own judgment and theoretical considerations. In addition to peripheral treatment I

should not fail to make galvanic applications to the spinal trophic centres (galvanization of the spine, of the sympathetic). But the results hitherto obtained by electro-therapeutics in these diseases are scarcely worthy of notice.

This also holds true of another rare and remarkable form of disease, the tonic spasms of voluntarily moved muscles, the so-called myotonia congenita (Struempell). The various attempts to relieve this peculiar disease by electricity have proven useless.

V. PAIN NEURALGIA AND NEURALGIFORM AFFECTIONS.

LECTURE XXV.

Introduction—Definition and Nature of Pain and Neuralgia—The Neuralgic Change—Electro-therapeutic Objects : Removal of the Abnormal Nutritive Conditions in the Nerves and of the Causes of the Neuralgic Change ; the Actions of the Current Available for this Purpose ; Cases—Electro-therapeutic Methods : Causal Treatment—Anti-neuralgic Methods : Direct, Application of the Galvanic and the Faradic Current ; Indirect, Electro-cutaneous Brush ; Galvanic Treatment of Painful Points—General Plan of Treatment—Results.

Those morbid irritative processes in the sensory nerves which are manifested as hyperæsthesia and pain are very often the object of electrical treatment.

It is especially those forms of painful irritation of the sensory nerves which have a certain independence, appear as peculiar, well-defined morbid processes, and are included under the general terms neuralgia and neuralgiform pains against which the efforts of electrotherapeutists are preferably directed. But the electrical current has also proven useful in not a few cases of other painful affections, which have nothing in common with neuralgia and do not even merit the name of symptomatic neuralgia.

The indications for the employment of electrical currents against pains and neuralgias were not so evident as in paralysis ; so long as electricity was known as a nerve-irritant alone its application in irritative conditions of the sensory nerves could not be regarded as very promising. However, electrical currents were employed in pain and neuralgia long before the modifying, sedative action of the current had been recognized, and the undoubted and frequent successes soon formed a broad basis for further investigations in this field of therapeutics. At the present time we possess in the electrical current one of the most certain and brilliant remedies for neuralgia, although we must admit that much progress has not been made in our knowledge concerning its mode of action in these forms of disease.

In this instance, also, it appears unavoidable to throw a glance at the question of the nature of pain and neuralgia, since in this manner alone

can we arrive at a rational electro-therapeutics. But the outlook is not very consoling. Despite the daily occurrence of these symptoms and forms of disease, despite centuries of observation and investigation, we are still deplorably ignorant with reference to the nature and pathogenesis of pain, and especially of neuralgia.

Pain is produced by every sensory irritative process which exceeds a certain intensity; it is the reaction of consciousness upon a certain strength of centripetal stimulation. This intensity of stimulation may be produced either by the greater intensity of the stimulus or by an increase in the irritability of the sensory apparatus, so that very slight stimuli will give rise to the pain-producing process of excitation. But here the uncertainty begins, because we do not always know—perhaps only in the rarest cases—in which of these two ways the pain of disease is produced. Probably, however, we have to deal generally, in pathological cases, with an increased excitability caused by finer nutritive disturbances of the sensory apparatus, so that the ordinary slight physiological stimuli, such as the movement of the blood and of parts of the body, tension of the tissues, perhaps also chemical substances in the blood and fluids of the tissues, may give rise to a sufficient intensity of the irritative process.

Still more difficult is it to form a conception of what is known as neuralgia and the recognition of its more intimate relations to the causal factors. The term neuralgia refers to pains of great intensity and peculiar quality which arise spontaneously, *i. e.*, from pathological processes in the body itself, are confined to one or more definite nerve-trunks, are perceptible throughout the entire distribution of the latter and present distinct exacerbations and remissions, even complete intermissions. These pains appear to be produced, in many cases, by finer nutritive disturbances in the nerves, which elude our present histological methods (as in idiopathic neuralgias, those due to exposure, malaria, poisons of all kinds, anæmia, hysteria, neurasthenia, spinal irritation); while, in a large proportion of cases, they are the results, or, at least, the concomitants of grosser anatomical changes in various parts of the sensory apparatus (injuries, foreign bodies, compression, inflammation and degeneration of the peripheral nerves, neuromata, diseases of the spinal cord, tabes, probably also diseases of the brain, syphilis, etc.). More careful consideration shows, however, that all these factors do not give rise to neuralgia in a direct manner, and that neuralgia is entirely different from the sensory irritation directly produced by its causes. We are thus forced to the conclusion that the action of these factors gives rise to the production of something else in the nerves which causes the neuralgia, and the hypothetical conclusion has thus been reached that neuralgia is a distinct, peculiar form of nutritive disturbance in the sensory nervous apparatus to which Moebius has applied the term "neuralgic change." This peculiar change in the nerves gives rise to the characteristic symptomatology of neuralgia.

So long as it lasts, the neuralgia also will last ; if its causes continue, the "neuralgic change" will continue, or, if it has been temporarily removed, will be produced anew ; this change may also acquire a certain independence and continue after the cessation of its causes (habitual neuralgia). This change may be established, as it seems, in various parts of the sensory tract (in the peripheral as well as the central course) ; at all events, it is not proven that it is always found in one spot, for example, in the posterior spinal roots or in the ganglion cells of the posterior gray columns ; we know still less concerning the real character of this "neuralgic change" and it is, at all events, not probable that it is due under all circumstances to hyperæmia or slight neuritis.

It is not my office to enter in detail into the symptomatology of neuralgia. I will merely emphasize the fact that it is important to the electro-therapeutist to be accurately informed with regard to the location of the neuralgia in this or that nerve-trunk, if possible concerning its height in the conducting fibres and its grosser causes, the primary disease, etc. ; that he should not fail to be informed with regard to the presence or absence of Valleix, painful points, and that it is advisable, in many cases, to search for more remote painful points, especially in the neighborhood of the spinal column (apophyseal point of Trousseau).

Electrical examination has acquired hitherto no noteworthy significance in neuralgias and has not added anything to the recognition of the finer molecular changes in the sensory nerves—perhaps because they have not been carefully sought after. The electrical examination has been confined to the demonstration of hyperæsthesia or anæsthesia of that portion of the integument affected with neuralgia, of painful points in the nerve-trunk or its branches, or finally of galvanic painful points upon the vertebral column (M. Meyer, Brenner).

From these introductory remarks it follows that the first electro-therapeutic object in neuralgia is the removal of the abnormal condition of nutrition and excitation in the nerves, in other words, of the "neuralgic change." But even if this is effected—and, as it seems, it may be done by the electrical current with some amount of certainty in many cases—it will not suffice to produce a permanent cure of the neuralgia in all cases ; if the causes of the latter continue, the disease will again develop. We have, therefore, a second and often much more important and difficult object, viz. the removal of the causes of the neuralgic change. I will confine myself to a brief consideration of those effects of the current from which we may expect, with more or less reason, a favorable influence upon the neuralgia.

As the clinical phenomena force us to assume very slight changes of nutrition and of the molecular conditions in nerves affected with neuralgia, and as we may assume that these changes are accompanied, in the majority of cases, by increased excitability, we must rely chiefly upon the modifying

effects of the electrical current, i.e., diminution of irritability, production of anelectrotonus, the so-called sedative (antineuralgic) action.

The catalytic effects may also be utilized in the removal of the finer nutritive disturbances, and these also possess a decided action upon an entire series of causal factors of neuralgia, viz., hyperæmia, neuritis, degenerations, all possible diseases of the brain and spinal cord.

Finally, the stimulating effects may also be employed for the production of very vigorous sensory irritation, which possesses an extensive application as a so-called "counter-irritation" in neuralgias and other painful affections. However obscure this notion may be, it has nevertheless been established by experience that conditions of abnormal sensory irritation may be relieved, temporarily or permanently, by sensory irritation, either in the same, or in symmetrical, or in remote nerve paths, whether this is accomplished by molecular transformations, or by over-stimulation and exhaustion, or by means of central inhibition (perhaps, also, by reflex circulatory changes and the like). At all events, the electrical current is one of the most certain and vigorous, as well as harmless, means of producing a strong counter-irritation.

Whether these actions of the current are the sole ones which are available in neuralgia or not, there is no doubt that the personal experience of every electro-therapist furnishes numerous examples of the admirable curative properties of electricity in neuralgia. I will now give a few illustrations of the recoveries which may be secured by various methods :

89. *Observation by Weise. Intermittent right supra-orbital neuralgia.*—At the end of December, 1866, after a coryza, an attack of supra-orbital neuralgia developed, assumed an intermittent character, and recurred daily in very violent paroxysms which ended with perspiration. Quinine and arsenic useless. Galvanic treatment begun January 17, 1867: An to the supra-orbital foramen, Ca to the neck stabile for three minutes, with 8 elements. Considerable relief forthwith; the neuralgia disappeared permanently after the close of the sitting. Fresh attack of same neuralgia twelve years later, which did not yield to quinine, but disappeared after a single stabile application of the An.

90. *Personal observation. Intermittent right supra-orbital neuralgia.*—A man, aged fifty years. Sick for two weeks; characteristic localization of the pain in the supra-orbital; no coryza, no malaria. Violent pain from 8 A.M. to 5 P.M.; freedom from pain at night; painful point.

February 17, 1882.—Galvanic treatment with An stabile; no paroxysm in following three days.

February 20th.—Return of pain. Second sitting followed by cessation of pain, which returned in very mild form. Complete recovery in two further sittings.

91. *Personal observation. Neuralgia of the right trigeminus (third branch).*—A woman, aged forty years. Had a similar affection on the left side ten years ago, which lasted a year. For two months pain in the distribution of the right infra-maxillary and auriculo-temporal nerves, occurring with

special violence toward evening and during the night. Painful points at the mental foramen and in front of the ear.

February 16, 1866.—Galvanic current, descending stabile through the auriculo-temporal nerve and along the lower jaw (two to three minutes in each position). No pain during the next night for the first time in many weeks. Permanent recovery after five sittings.

92. *Personal observation. Neuralgia of the right trigeminus (tic-douloureux).*—A woman, aged forty-seven years. Suffering for four years from an increasing violent facial neuralgia, chiefly in the infra-orbital nerve, affecting the malar bone, superior maxilla, nose and upper teeth, and, at the height of the paroxysm, radiating into the inferior maxilla and lower teeth. Active spasmodic twitching around the angle of the jaw during each attack. Origin unknown; no distinct painful points. At first galvanic treatment: An stabile, for three to four minutes, upon the upper and lower jaws and in front of the ear, the current being gradually increased and diminished; no sign of improvement after five sittings. Then 8 elements stabile from the forehead to the neck, galvanization of the sympathetic, and An stabile in front of the ear; no improvement after three sittings. Then faradization transversely through the head, Ca on the right side, with increasing currents. Improvement forthwith, which continued to make considerable progress during the next two weeks, so that the patient had complete rest at night, the reflex spasm disappeared, and very few mild paroxysms occurred during the day. The patient was compelled to discontinue treatment.

93. *Observation by Moritz Meyer. Trigeminal neuralgia*—A woman, aged thirty-five years. Suffering for three months from violent neuralgia of the left trigeminus, mainly in the third branch, occurring in five to six paroxysms daily. Quinine, arsenic, veratrine ointment useless. Faradic brush to the neck at first produced great increase of pain for half a day, then striking amelioration. Permanent recovery after two more sittings.

94. *Observation by Wiesner. Trigeminal neuralgia (tic-douloureux).*—A man, aged sixty-four years. Suffered for four years from left trigeminal neuralgia (in the malar bone and deep in the skull). Various operations caused merely temporary relief. Recently twenty to thirty paroxysms daily of great violence; 0.50 morphine administered daily. Galvanic treatment (the most painful parts placed between the electrodes twice a day, for five minutes) caused improvement in three days, which slowly progressed; the tic disappeared after two months, and the patient was discharged as cured for the present.

95. *Observation by Moritz Meyer. Right occipital neuralgia.*—An officer, aged thirty-two years. Suffering for two months from violent pains in right occiput and neck. Vigorous faradic brush to the neck; immediate subsidence of the pains, and complete recovery after two sittings.

96. *Personal observation. Neuralgia of the median nerve.*—A woman, aged twenty-eight years. Suffering for six weeks from violent neuralgic disturbances in the distribution of the right median nerve, from the elbow to the fingers. Nocturnal exacerbation of pain. Galvanic treatment, descending stabile through the median for three to four minutes. Much less pain on the following night; recovery after the second application.

97. *Personal observation. Neuralgia of the radial nerve.*—A girl, aged eight years. Suffering for nine weeks from severe pain, and marked hy-

paræsthesia of the right thumb ; the pain radiates along the radial border of the thumb and forearm across the outer surface of the arm to the shoulder ; very distinct painful points in several positions. The thumb extremely sensitive to the slightest touch ; complete inability to use the hand ; no swelling or inflammation. Galvanic treatment : 8 to 12 elements descending stabile from the radial nerve in the arm to the thumb and wrist-joint ; eight elements An stabile upon the plexus. Distinct improvement after two sittings, complete recovery after nine sittings.

98. *Observation by Seeligmüller. Neuralgia of the lesser internal cutaneous nerve of the arm.*—A woman, aged forty-three years. Suffering for eight years from neuralgic disturbances in the left arm ; examination discloses a neuralgia confined to the lesser internal cutaneous nerve. A painful point along the spine. Galvanic treatment : Ca on the painful point, An stabile to the nerve in the arm for six to ten minutes, the current being gradually increased and diminished. After the first sitting the patient was free from pain for twenty-four hours, for the first time in eight years. The patient was discharged cured after a few more sittings.

99. *Personal observation. Intercostal neuralgia ; herpes zoster.*—A girl, aged fifteen years. Suffering for four days from intercostal zoster, corresponding to the fourth to seventh intercostal nerves, with neuralgic pains in the same distribution. These pains continued for two weeks despite internal treatment. Galvanic treatment. Pains disappeared in five days. After discontinuance of treatment, pains returned in five days. Renewal of galvanic application produced recovery in ten days.

100. *Personal observation. Intercostal neuralgia ; mastodynia.*—A girl, aged twenty-six years. Suffering from eight to nine months with shooting pains in the breasts, accompanied by secretion of milk ; pains sometimes very severe, remittent and radiating into the back and inner aspect of the arms ; tenderness of most of the dorsal vertebræ ; anæmia. Galvanic treatment : An upon the dorsal spine, Ca on the sternum, 14 to 20 elements stabile. Distinct improvement after a few days, but no further progress. Then faradic treatment (strong currents with large moist electrodes) ; also followed by distinct improvement, the disease being reduced to two slight attacks daily. Complete recovery not effected.

101. *Personal observation. Sciatica.*—A man, aged twenty-three years. Suffering for five days from neuralgic pains in both legs, from the hips to the feet. Exacerbation at night so that patient was unable to sleep ; paræsthesiæ in the feet. Galvanic treatment descending through the sciatics, the electrodes being applied at a distance of six inches from one another along the entire course of the nerves ; a few interruptions. Pain diminished forthwith, and patient able to sleep tolerably well. No pain at night after the second sitting. Cured after fourth sitting.

102. *Personal observation. Sciatica.*—A man, aged fifty-five years. Suffering for three months from left sciatica ; characteristic localization of the pain, with several painful points ; violent paroxysms, especially at night ; sleep disturbed ; left leg somewhat emaciated ; walking interfered with. Hypodermic injections of morphine useless. Galvanic treatment : descending stabile through the nerve, with a few interruptions of the current at the close. Considerable improvement after the first sitting, and complete recovery after nine sittings.

103. *Observation by Moritz Meyer. Sciatica.*—A merchant, aged forty-four years. Suffering for six months from right sciatica in consequence of a railway injury. Very violent pains ; painful point at the sciatic fora-

men. Faradic brush in this region followed by immediate disappearance of the pain ; reappeared to a slight extent on the following day. Recovery after two further sittings.

104. *Observation by Brenner. Sciatica.*—The patient suffered for four months from extremely violent sciatica, and was compelled to lie in bed for a month at the beginning. Peripheral electrical treatment ameliorated the pain in the leg but not in the upper part of the sciatic and the ileo-hypogastric pain. Examination showed intolerable pain upon application of the Ca to the dorsal and lumbar vertebræ, which were not tender on pressure. Application of the An to these parts produced considerable relief forthwith, and after eight sittings patient was almost entirely free from neuralgic pains ; galvanic painful point disappeared.

105. *Self-observation by Brenner. Neuralgic pains in the foot as the result of articular rheumatism.*—During an acute rheumatic polyarthritis, in which both ankles were affected, Brenner suffered from violent paroxysmal pains radiating into the feet, which resisted all remedies and rendered sleep impossible for three weeks. A single application of a moderately strong faradic current to the ankles with broad moist electrodes, relieved the violent pain immediately and permanently.

From these observations it follows with certainty that many cases of neuralgia are cured by the electrical current in a surprisingly rapid manner and that this may be effected by various methods. But the superiority of one method over another cannot be inferred by any means, nor does this follow from the statements of those who have adopted a certain method more or less exclusively. In individual cases it would seem that, when one method fails, another may prove useful, but this does not occur often, by any means, and I have very frequently had the impression that those forms of the disease which will yield to electrical treatment, will be favorably affected by every form of current and every method of application which is not entirely irrational.

In the determination of the electro-therapeutic method our first object, in many cases of neuralgia, is the removal of the causal disease. I have very little to add, in this respect, to the remarks made in previous lectures (Lectures XVI. to XXI.). We have to deal mainly with the electrical treatment of those diseases of the brain, spinal cord, and peripheral nerves which give rise to neuralgia or neuralgiform pains. Their treatment is carried out according to previously mentioned principles and methods, and must be resorted to at the onset in so-called symptomatic neuralgias (tabes, meningitis, neuritis, etc.) ; as a rule, we must apply the galvanic current, more rarely the faradic current for the sake of its reflex effects from the integument.

But as not a few neuralgias are developed in general neuroses (hysteria, neurasthenia, spinal irritation, diabetes, etc.) or in general constitutional anomalies (anæmia, chlorosis, cachexiæ of all kinds, etc.), electrical treatment directed against these conditions may be useful occasionally. Under such circumstances general faradization may be recommended very

highly, and likewise general or central galvanization. I will return to this subject in subsequent lectures.

But the main purpose to be effected, under all circumstances, in idiopathic and symptomatic neuralgias, and which may be attempted even though the primary affection is incurable, is the removal of the morbid conditions in the sensory nerves themselves, of the "neuralgic change," *i.e.*, the production of an anodyne, antineuralgic action of the electrical current. This may be secured either in a direct or an indirect manner.

As a rule, the direct method is adopted first, either the galvanic or the faradic current being employed. Its object always is the diminution of excitability and the modification of the nutritive conditions of the sensory nerves—*i.e.*, the production, in a certain sense, of a catalytic action. Above all, the stable action of the galvanic current should be employed, and the stable application of the An should be made to the diseased part on account of its notoriously sedative, anelectrotonic action. The An should be placed upon the site of disease, at all events upon the painful nerve-trunk, over as large a surface as possible, perhaps, also, upon the individual painful points. The application should be moderately strong, but gradually increasing in intensity, and somewhat prolonged. Very vigorous stimulation, especially interruptions of the current, should be carefully avoided, and in many cases it seems indispensable to diminish gradually the strength of the current at the close of the anodal application, in order to avoid the "opening" irritation and the subsequent positive modification of irritability; this is very readily effected by gradually diminishing the number of elements, or by means of a suitable rheostat. The position of the Ca may be entirely indifferent, and should, at all events, be made in such a manner that the An, according to the laws of the diffusion of the current, possesses the most intense effect possible; the Ca may afterward be applied upon certain painful points. This method does not always produce the desired object, and a trial of the stable application of the Ca is then by no means excluded; it is possible that the catalytic action of this pole may have a more favorable effect upon the "neuralgic change," and thus prove curative. At all events, a large experience teaches that the application of the Ca to the painful points (even if the An is not applied directly to the nerve-trunk) may have a favorable antineuralgic action. I have frequently seen the lancinating pains of locomotor ataxia, especially when associated with circumscribed hyperæsthesia of the skin, disappear as if by magic from the application of the Ca to these portions of the skin (An upon the spinal column).

As we have to deal mainly with large tracts of nerves, for example, with the nerves of the extremities, both poles may be applied to the nerve, and the current allowed to flow either in an ascending or descending direction. As a rule, the descending current is preferred for this purpose, and a greater sedative action is attributed to it—whether justly, has been

scarcely decided, but it probably depends upon the fact that the An is applied to the central portion of the nerve. The chief requirement is its stable application, in addition to the avoidance of unnecessary irritant effects. The An is placed as centrally as possible upon the nerve-trunk or the vertebral column, the Ca upon a more peripheral part, especially upon the individual painful points. When the nerve is very long, several of these applications may be made in succession from the centre to the periphery, the electrodes being situated at a distance of about twenty to twenty-five centimetres from one another (especially in sciatica). When the neuralgia occurs in mixed nerves and is associated with stiffness, weakness, and pain in motion, it may be useful to produce a few muscular contractions by closure of the current at the close of the sitting; the concomitant symptoms are usually relieved by this procedure.

Finally, another effective procedure is the constant application of weak galvanic currents (*vide* page 120), which has been recommended on all sides. I possess no very large personal experience with this method, but believe that it is to be specially recommended for very irritable individuals with fleeting or often-recurring neuralgias, particularly in spinal irritation and hysteria. It should not be forgotten, with regard to the choice of the site of application, that the zinc plate of simple galvanic elements is the anode.

The same object is subserved by the passage of a moderately strong faradic current through the diseased nerve (by means of moist electrodes); how this acts it is difficult to say, but the fact of its efficiency is undoubted. It is best to begin with moderately strong currents, which are passed through the nerve for three to ten minutes; this produces great relief at the onset, and perhaps recovery after repeated applications. If recovery does not ensue, a stronger current should be employed, perhaps in the form of the so-called "swelling" current, gradually increasing and diminishing.

In an indirect manner, good results in neuralgia may also be obtained in various ways. In the first place, by the production of a violent counter-irritation with the aid of the faradic brush. This method, which has been often employed with brilliant results, but is not very agreeable to the patient because very painful, consists in vigorously stimulating the skin by means of the electrical (faradic or galvanic) brush. According to Duchenne, the irritation of the skin is effected in the neighborhood of the painful spot, or, if this is not sufficiently sensitive, in some other part. Moritz Meyer states that good results are only obtained from this procedure when anæsthesia of the skin is present in addition to the neuralgia. According to him, a better effect is obtained from the application of the so-called electrical moxa (fixation of the electrical brush upon a certain part of the skin, or the passage of sparks from the brush, which is removed one millimetre from the skin) to the principal painful point on the nerve,

or to its point of exit from the central organ. This application should last from a few seconds to a minute. If it does not produce the desired effect in a short time (after two to five sittings), similar counter-irritation may be applied to the corresponding parts on the healthy side, or to the distribution of adjacent cutaneous nerves, or even to remote parts of the skin (helix of the ear, wing of the nose, nipples, neck, etc.).

A case reported by Wiesner proves that the galvanic (Ca) brush is also available in the same manner. One of my colleagues kept within bounds a very severe supra-orbital neuralgia of many years' standing by the application of the galvanic brush to the forehead, but he moderated the disagreeable features of the application by the interposition of moist tissue-paper. Seeger has employed a similar procedure in sciatica; he strokes large portions of skin over the diseased nerve with the cathode brush, until redness and wheals are produced (and then employs these parts, which are thus converted into better conductors, for the application of moist tissue-paper and the introduction of the current through it by means of ordinary electrodes).

The galvanic treatment of the painful points upon the spinal column, etc., may also be regarded as an indirect treatment of neuralgia. Moritz Meyer, Seeger, and Brenner have directed their attention to this method, and found it useful in many severe neuralgias (brachial and intercostal neuralgias, sciatica, etc.). The method consists of the stable application of the An of a moderately strong current.

General principles, and, to a still greater extent, the peculiarities of the individual case are decisive with regard to the intensity and duration of all these methods of treatment. Under all circumstances it is advisable to begin with weak currents and short sittings, to avoid unnecessary irritative action, sudden closure and opening of the current and the like, and not to omit the gradual diminution of the current. More than three to five minutes of a galvanic, and five to ten minutes of a faradic application are scarcely necessary; a number of sittings in one day sometimes prove useful.

With regard to the general plan of treatment, it is advisable to begin with milder procedures, especially when we are not acquainted with the patients or they are very sensitive. In the beginning, therefore, in addition to the causal treatment, make a stable application of the An or weak descending galvanic currents, perhaps also feeble faradic currents, which, in very sensitive individuals, may be applied by means of the "electrical hand." Stronger currents, the faradic brush or the moxa, should not be employed until the former methods prove unsuccessful.

The results of these various forms of treatment are often very brilliant, and it may be said, on the whole, that neuralgia is one of the most gratifying objects of electro-therapeutics. At least a temporary benefit is obtained in almost all cases; the patient experiences relief during the passage

of the current, and the pain has either entirely disappeared or is considerably relieved after the close of the application. But this is not always the case, as there are forms in which not even temporary benefit is obtained, the pains continue with undiminished severity, and are even increased by the electrical current; it is rare that such an increase of the pain is followed by permanent improvement (*vide* Observation 93). In such cases the treatment should not be long continued.

In favorable cases the temporary improvement may continue, and the disease is cured after one or two applications. Or the pain returns, perhaps with diminished severity, after a longer or shorter interval. Each new sitting produces renewed relief, until finally recovery occurs after a longer or shorter period. You should not be repelled in such cases by the trouble of long-continued treatment. In unfavorable cases the temporary improvement does not make any progress, and the neuralgia remains incurable; the causes apparently lie in the character and incurability of the primary disease, but we are not always able to recognize this fact, and apparently very favorable idiopathic neuralgias may present an unexpected resistance to electrical treatment.

It is not easy to foretell whether a neuralgia is curable by electricity or not. The diagnosis is too uncertain in many cases for such a purpose. But experience teaches that the outlook is relatively favorable in pure idiopathic neuralgia, in the rheumatic and neuritic forms, in those due to anæmia, neurasthenia, and hysteria, perhaps also in many malarial neuralgias. It is unfavorable, on the other hand, and palliative effects may, at the most, be looked for in the majority of symptomatic neuralgias, as in affections of the brain and spinal cord, in severe peripheral nerve lesions, in chronic hysteria and neurasthenia, and especially in the severe facial neuralgias which are known as true *tic-douloureux*.

LECTURE XXVI.

Individual Forms of Neuralgia: 1. Trigeminal Neuralgia; Practical Remarks Concerning the Individual Methods of Treatment—2. Cervico-occipital Neuralgia—3. Headache and Migraine; Various Methods of their Treatment—4. Cervico-brachial Neuralgia—5. Intercostal Neuralgia—6. Neuralgia of the Lumbar Plexus—7. Sciatica; Various Methods of Galvanic and Faradic Treatment; Neuralgia of the Urinary and Sexual Organs; Coccygodynia—8. Neuralgia of the Joints—9. Visceral Neuralgias: Neuralgia of the Pharynx and Larynx; Angina Pectoris; Gastralgia; Enteralgia; Lead Colic; Neuralgia in the Distribution of the Pelvic Nerves.

AFTER the previous detailed remarks concerning the electro-therapeutics of neuralgia in general, I may restrict myself to a brief consideration of the individual forms.

1. *Neuralgia of the trigeminus and its branches* presents great difficulties to electrical treatment on account of the deep situation of the nerve and its branches, and also frequently on account of the severity and incurability of the disease (morbid processes at the base of the skull, aneurism of the carotid). Slight consideration will show that the trunk of the nerve, the ganglion of Gasser, and the three main branches lying deep in the middle fossa of the skull, cannot be readily influenced by the current, and this is also true concerning a portion of the course of the branches within and upon the floor of the orbital cavity and in the sphenopalatine fossa. It will not be easy to produce a vigorous polar action in these localities, and still more must we renounce the production of a definite effective direction of the current in the nerve. The most serviceable method for the production of polar action will be the transverse or oblique conduction of the current from the middle of the temporal region, immediately above the malar bone, to the other side, or from behind the ear to the opposite side of the back of the neck. For the production of a definite direction of the current in the main branches the passage of the current from the neck to individual points of exit of the nerve will scarcely be sufficient. We must help ourselves, in this respect, as best we may, and I think it best always to keep in mind the following object, viz., to bring the presumably diseased portion of the nerve within the field of the densest portions of the current, i.e., between both electrodes or in the immediate vicinity of one of them. Some of the peripheral branches of the nerve, especially the supra-orbital, auriculo-temporal, also the inframaxillary, are

much more favorably situated in this respect. They may be readily subjected to polar action or to the passage of a descending current. This is effected less readily in the infra-orbital nerve, the terminal ramifications of which alone can be vigorously influenced; and this very nerve is by preference the site of severe "epileptiform" neuralgia, the true tic-douloureux.

The treatment of these neuralgias is begun by the stabile application of the An to the individual branches and points of exit, or in the neighborhood of the main trunk. The Ca may be placed upon the sternum or in the opposite hand, or on the posterior or lateral part of the neck; the current should be gradually increased and diminished, at first of moderate, later of greater strength. If the disease is supposed to be situated at the base of the skull, you must employ quite strong currents. O. Berger has obtained very good results from this method, and it proves sufficient for the majority of milder cases. If it is ineffective, you may resort to the stabile application of the Ca to the points of exit of the nerve, or send a descending current through the individual peripheral branches, the An being fixed in the neck; or the same application with feeble, gradually increasing, faradic currents; Bruzelius recommends that the latter applications should be long continued (ten to thirty minutes). Finally, trial may be made of the faradic brush or moxa (perhaps also of the galvanic brush). These can hardly be employed in the face, though I have repeatedly tried it; a better method is the application of the brush to the neck. M. Meyer employs two brushes, one being placed on the neck, the other in its immediate neighborhood, about one millimetre from the integument, in order to allow the passage of sparks; the faradic brush may also be applied to the helix of the ear.

Not infrequently cases will be met with in which all these methods of treatment fail of success, especially in tic-douloureux. Permanent relief is very rare in these cases, and I openly confess that I cannot boast of a single cure in these severe chronic neuralgias, however many I have treated methodically and persistently. The most that I have obtained was the temporary cessation of the attacks or a variable degree of amelioration; now and then, however, recovery may result. I will add that two or more sittings daily have appeared to me to be useful in some cases.

2. The electrical treatment of *cervico-occipital neuralgia* does not present the slightest difficulty, since we have to deal with superficial, quite long nerve-trunks, which can be readily influenced as far as their entrance into the central organ, and whose most frequent sites of disease are usually reached with facility. The methods are therefore readily determined; in the first place, the stabile application of the An to the points of exit, *i.e.*, the upper cervical vertebrae, the Ca upon the sternum; or the descending stabile current, the Ca being placed upon the thoroughly moistened scalp; the faradic current may be employed with moist

electrodes in the same manner ; finally, the faradic brush or moxa high up in the neck. The results are usually admirable, but some cases occur which resist treatment. The rare phrenic neuralgia is treated according to the same principles.

3. I must devote some consideration to the electrical treatment of *headache and migraine*, since it often proves very serviceable to patients suffering from these affections.

As a matter of course I refer alone to the so-called "nervous" headache, as it occurs under the most varied conditions, with or without gross lesions upon or within the skull, most frequently in neurasthenia, hysteria, anæmia, or as the result of rheumatism, toxic agents, etc. Other forms of headache (in fever, syphilis, inflammations of the skull, coryza, meningitis, etc.) are scarcely ever the object of electro-therapeutic trials.

It goes without saying that, in all such cases, the determination of the cause of the nervous headache is decisive with regard to treatment, and often some other remedy will better meet the causal indication than electricity. Only in neurasthenia, hysteria, etc., can the causal indication be sometimes met by general faradization or some other electrical procedure. Direct treatment of the headache may be tried in addition ; this should be done in all cases in which no causal indication can be found or fulfilled. This may be accomplished in various ways. When the pain is diffused, it is best to begin with the passage of weak galvanic currents longitudinally through the skull ; if distinct vaso-motor disturbances are also present, you may place either the An or Ca upon the forehead, according to circumstances ; in such a case galvanization of the sympathetic or the cervical cord may also be employed. Good results are often obtained from the stabile application of the An (large head electrode) to the scalp, the Ca being placed on the sternum, thigh, or hand, with a moderately strong current. I have occasionally obtained very favorable results from the passage of a weak faradic current from the forehead to the neck (two to five minutes), preferably by means of the "electrical hand ;" the faradic brush to the integument of the neck, chest, back, and upper limbs may be useful in some cases, especially when associated with vaso-motor disturbances. If the headache is of a more localized character and isolated painful points are present, the stabile anodal treatment of these points, or their faradization with moist electrodes, will prove serviceable. The results of all these methods of treatment cannot be foretold ; like other measures in these affections, electricity sometimes presents very brilliant, sometimes purely negative results.

That form of nervous headache which occurs in periodically recurring attacks of usually unilateral very severe pain, associated with nausea, vomiting, general prostration, various vaso-motor disturbances, etc., and is known as hemicrania or migraine, has naturally continued to call forth

electro-therapeutic measures. I must confess that such attempts are generally fruitless ; the brilliant results said to have been obtained by some authors (for example, Frommhold) by the electrical treatment of migraine have not been confirmed by others, and in this very respect migraine is distinguished from other neuralgias among which electro-therapeutics includes its greatest triumphs.

In the large majority of cases migraine is the expression of a congenital or acquired nervous disposition, and is due only in rare cases to temporary, occasional injuries. Whatever produces migraine in predisposed individuals upon slight cause, or increases the violence and number of the attacks, may also give rise to the disease for some time in those very slightly predisposed to it ; but it is then usually manifested by isolated and not very severe attacks. The latter form presents the most favorable chances by far for electrical treatment, and on several occasions I have secured very rapid recovery in such cases. On the other hand, true migraine, as it occurs in so many neuropathic women and neurasthenic men, especially in "brain workers," and usually continues until advancing years, is a disease which is influenced with difficulty, and is very rarely relieved even by the most careful electrical treatment ; we can scarcely ever hope for real recovery, and even any considerable amelioration is rarely effected.

The true nature of migraine is still entirely unknown to us, and therein lies a part of the difficulty of treatment. We know either in what part of the skull or its contents the pain is located, nor are we acquainted with its more intimate pathogenesis. The attempt to refer the pain to vaso-motor disturbances, to spasm or paralysis of the vessels, and, on the whole, to regard migraine as a disease of the sympathetic, I consider unfortunate, since in the majority of cases which I had the opportunity of observing, the much-discussed angiospastic and angioparalytic symptoms were absent during the attacks, and I must regard them, whenever present, as sequelæ or part-symptoms of the entire attack, the true nature of which is still entirely obscure.

The electrical treatment of migraine must therefore be restricted mainly to empirical measures, and clear indications concerning the choice of the method will only be presented when marked vaso-motor disturbances, symptoms of irritation or paralysis of the cervical sympathetic, are present.

As a matter of course the attempt should be made at the onset to relieve the primary disease, the constitutional neuropathy (neurasthenia, hysteria, anæmia, etc.), by electro-therapeutics (general faradization, central galvanization, electrical bath, etc.). You should then determine whether marked vaso-motor disorders are present during the attack ; if so, the method of treatment of the sympathetic developed by Holst, according to polar principles, should be instituted according to the character of these

symptoms (paralytic or spasmodic). In the angiospastic form of migraine (pale, cool face, rigid, narrow arteries, dilated pupil and palpebral fissure, increase of the pain upon compression of the carotid) a stable application of the An (two to five minutes) is made to the cervical sympathetic (Ca in the hand or neck), the current being gradually increased and diminished; in the angioparalytic form (red, hot face, pulsation of the dilated arteries, congestion of the retina, narrow pupil and palpebral fissure, diminution of pain during compression of the carotid) the Ca of a moderately strong current is applied to the cervical sympathetic (one to two minutes), and repeated openings and closures made, perhaps also a few interruptions; too strong irritation should be avoided, since more marked dilatation of the vessels would develop in consequence.

If no distinct vaso-motor disturbances can be demonstrated, you may, nevertheless, try one and then the other of Holst's methods; in addition, I have found some benefit from simple transverse and longitudinal conduction of the galvanic current through the head, associated with the ordinary form of galvanization of the sympathetic. Moritz Meyer cured a case by the treatment of painful points upon the cervical spine.

Finally, the faradic current may also be tried, either in the form of feeble, long-continued faradization of the head, preferably with the electrical hand, or also as the "increasing faradic current," which has been praised to such an inordinate extent by Frommhold. By means of large flat sponge electrodes the primary faradic current is passed from the neck (anode) to the forehead, or to that portion of the temple which is always affected by pain in migraine; a very mild current is first employed, and then increased slowly and progressively, until an intense sensation is produced in the head; from three to five minutes daily.

All these methods of treatment must be continued for a very long time, usually months, even for years (with intermissions), if a permanent effect is looked for. We can only speak of improvement or recovery if no attacks occur, or their severity and frequency at least have very much diminished, despite the ordinary exciting causes in females, especially during menstruation.

The electrical treatment of the attack itself is usually entirely useless, but Holst reports a few favorable results by his method, in paroxysms which were associated with marked vaso-motor phenomena. Frommhold also states that he has often obtained temporary relief, lasting sometimes for hours, by means of his method. I have hardly ever been so fortunate; but very recently I obtained, by means of the galvanic current, a magical effect upon an attack of very severe (anomalous) migraine. But such cases are exceptional, and electricity is not a certain palliative for paroxysms of this disease.

4. *Cervico-brachial neuralgias* in their various forms are often brought to the notice of the electro-therapist, and present no difficulty in the

choice of suitable methods of treatment. The results in the majority of rheumatic, neuritic, and similar brachial neuralgias, are usually very satisfactory, though they sometimes present an unexpected obstinacy. As in other cases, the prognosis of severe symptomatic neuralgias is very unfavorable.

The choice of the method of treatment depends entirely upon general principles. If possible, causal treatment in the beginning; then, according to personal preference, the faradic current along the chiefly affected nerve-trunks, or the faradic brush to the affected nerve distribution, or to the spinal column in the region of the points of exit of the nerves. With the galvanic current painful points should be sought for upon the spinal column, the plexus, or the affected nerves, and a stabile application of the An made to such points (Ca to the sternum or back); the treatment of the brachial plexus in the supraclavicular fossa with the An is especially important in many of these cases. In addition, descending stabile currents may be used, the An upon the plexus, the Ca upon the peripheral nerve branches, especially upon any points douloureux which may be present. If improvement is secured by such treatment, the stiffness and weakness, which may, perhaps, be left over in the muscles of the arm, may be removed by a few cathodal closures or by a labile application. When complicated with paralysis, the neuralgia should be treated first, then the paralysis.

5. *Intercostal neuralgias* often present a much less favorable prognosis, and are occasionally very obstinate. The rheumatic, neuritic, and traumatic forms are relatively favorable; but those forms which are due to vertebral disease (caries, carcinoma), meningeal tumors, pulmonary phthisis, tabes, and the like, are very obstinate and often incurable, while those varieties which are associated with herpes zoster in old people often present a surprising persistence.

In addition to the causal treatment, intercostal neuralgia may be treated in the ordinary manner with the faradic current. A more favorable effect is often obtained from the galvanic current, either from the application of the An to the various painful points, or successively along the entire length of the nerve (Ca indifferent; vigorous current), or from the application of the An upon or immediately adjacent to the spinal column, the Ca being placed laterally and anteriorly upon the individual painful points. *Mastodynia*, which is merely a variety of intercostal neuralgia, is treated in exactly the same manner.

6. *Neuralgia of the lumbar plexus* with its different varieties (neuralgia of the crural, lumbo-abdominal, obturator, and lateral cutaneous nerves) is treated according to the same principles as sciatica, which will be next considered. If it is not due to severe disease of the vertebræ or psoas muscle, of the pelvic organs, etc., it promptly yields, as a rule, to electrical treatment. As a matter of course, a necessary condition is the

most exact possible determination of the affected nerve tracts. We may employ a descending stabile current from the vertebral column (An) to the affected nerve trunks, or the stabile application of the An upon the vertebræ and then upon the nerve trunks and the chief painful points (Ca upon the posterior surface of the thigh or the knee), or the application of the faradic current in the well-known manner. If the saphenous nerve is implicated, it sometimes requires special treatment in the leg. A few cathodal closures or labile irritation at the close of the sitting appear to be not unimportant.

7. *Sciatica*, one of the most frequent neuralgias, is accessible to electrical treatment in very many cases. The disease is of common occurrence among the laboring classes, but it is not unknown in the higher classes. The individual cases differ greatly with regard to etiology, localization in the various nerves, severity and curability, and the results are therefore extremely variable; they are uniformly favorable in the rheumatic and neuritic forms, especially in recent and mild cases, also in those neuralgias due to inflammations of the joints and to injury; they are much more uncertain and often entirely negative in the symptomatic forms due to diseases of the pelvis, vertebræ, and spinal cord.

The methods of treatment are those ordinarily employed, modified by the deep position and great extent of the nerve, perhaps also by the site of the lesion. In the frequent rheumatic forms the galvanic current should be first resorted to; the descending stabile current (on account of the great length of the nerve), the An being placed upon the sacrum or in the region of the plexus or the sciatic foramen (if this is the chief site of the disease), while the Ca is placed lower on the nerve, upon the painful points or the main branches. According to Remak it is advisable to include small parts of the nerve (twenty to twenty-five centimeters long) in the current, and thus gradually pass along the nerve from the sacrum to the foot (for example, from the sacrum to the sciatic foramen, then from the latter to the popliteal space, finally from this to the ankle or the carpus), and allow a stabile application for one to three minutes in each spot; after some relief is obtained, a few closures of the current or a short labile application is made, by which means the not infrequent stiffness and feeling of heaviness in the muscles are most certainly relieved. The deep position of the nerves and the great resistance of the integument to conduction in the parts in question (with the exception of the region of the knee-joint) necessitate strong currents and large flat electrodes, especially if the patient is obese. The entire duration of a sitting should be four to ten minutes. It is not infrequently necessary to apply direct treatment to the individual branches of the nerve.

I have obtained no less good results with the purely polar method, the anode being applied stabile to the various parts of the nerve (lumbar vertebræ, plexus, sciatic foramen, points douloureux) and the cathode to the

anterior surface of the abdomen or thigh ; strong currents are necessary, and a few interruptions are often useful in increasing the effect. The "circular current" of Remak (fixation of the An upon the site of the lesion or pain, while the Ca is applied successively to a large number of points lying in a circle around the An) is probably identical with the polar anodal treatment.

In particularly obstinate cases you may try Benedikt's plan of introducing one electrode into the rectum, the other being applied to the region of the sacrum and loins, thus placing the sciatic plexus as directly as possible within the current, and influencing the lesion more intensely. Ciniselli recommends the prolonged application of simple galvanic elements ; they may be fastened to the limb and back, and worn for days and weeks.

Treatment with the faradic current may also meet with success, and should be employed in the ordinary manner, either by the passage of a very strong faradic current through the trunk of the nerve and its branches, or by the application of the faradic brush to the integument of the sciatic distribution, and the faradic moxa over the sciatic foramen, sacrum, lumbar vertebræ, etc. Seeger has also employed the galvanic brush with success.

Other symptoms, such as anæsthesia, paralysis, or muscular twitchings and spasms, require special treatment according to well-known rules.

All other forms of sciatica are treated according to the same methods, except that in many cases an especial causal application is superadded (in tabes and other diseases of the spinal cord and the like).

Neuralgias of the urinary and genital organs (pudendo-hæmorrhoidal, spermatic, urethral, ano-vesical neuralgia, etc.), which also belong to the sacral plexus, are of rare occurrence, and sufficient electro-therapeutic observations with regard to them have not been obtained. As a matter of course, galvanic and faradic currents may be applied—and often with evident advantage—in these forms, and it will not be difficult for you to determine the method suitable to each individual case. This is also true of so-called coccygodynia, in so far as it requires the application of electricity on account of its true neuralgic character. Favorable results have also been obtained in this affection (Seeligmueller).

8. *Neuralgias of the joints* (articular neuroses) also require a brief consideration. In part they undoubtedly belong to the true neuralgias, develop in the large majority of cases upon an hysterical basis, and their treatment therefore forms part of the therapeutics of hysteria (*vide* Lecture XXXI.). They are most frequent in the knee and hip joints, more rare in the joints of the hands, feet, and shoulders. They may be associated with all the classical symptoms of hysteria, but often present very great difficulty in diagnostic differentiation from inflammatory, carious, and fungous processes in the joints. In all such cases, however, a trial

with electrical treatment will do no harm, and the rapid success of such an application may contribute greatly toward clearing up the diagnosis.

The various antineuralgic methods of application of electricity may also be serviceable in articular neuroses; in addition to the electrical treatment directed against the primary affection, the transverse passage of feeble, afterward of strong galvanic currents through the diseased joint; or the isolated stabile application of the An, with the aid of large sponge electrodes, or moist compresses, which surround the entire joint, and serve as the An (Ca indifferent), or with small electrodes upon the principal painful points on the joint and upon any painful points which may be present in the spinal column; anodal applications to the nerve trunks supplying the joint may also prove advantageous. If our object is not effected in this manner, we may pass vigorous faradic currents transversely through the joint, or apply the faradic brush energetically to the integument of the joint, the painful points, or the corresponding part of the vertebral column. The experience of O. Berger and Moritz Meyer, which I can confirm in part, teaches us that success is obtained occasionally by all these methods.

106. *Observation by Berger. Articular neuralgia.*—A woman, aged thirty-eight years. Increasing pains in the knee-joint after a contusion of this part. Rest in bed, blisters, cotton-batting, etc., increased the suffering, which was associated afterward with muscular contractions and formication. Status at the end of four weeks: halting gait, pain in the knee, no external abnormality of the joint; painful contractions of the flexor muscles; tibial nerve tender on pressure; extreme cutaneous hyperalgesia of the knee-joint and the lower third of the thigh. Treatment: faradization, An in the popliteal space, faradic brush to the skin over the knee and neighborhood; strong current for four minutes; faradic moxa upon a painful point near the patella. Immediately afterward the patient walked almost half an hour without pain. Another sitting held on the following day, although the symptoms had disappeared; cure permanent.

107. *Observation by Berger. Articular neuralgia.*—An anæmic and nervous lady, aged forty-five years, suffered a contusion of the right knee in December, 1872. After a number of weeks, violent pains in the joint, radiating upward and downward, resisting all treatment, and finally implicating the left knee. Two months in bed without improvement.

July, 1873.—Cutaneous anæsthesia and analgesia in the right knee-joint with frequent formication; a painful point on each side of the capitulum fibulæ, also in the right popliteal space. The patient can walk only a few steps when led, the pains being extremely violent. Treatment: stabile galvanization of both knee-joints with a moderately strong current for eight minutes. Considerable improvement immediately after the sitting; the patient was permanently cured of her disease, which had lasted many months, after seven sittings.

9. The so-called *visceral neuralgias* are still so obscure with regard to their character and development, that it is difficult to meet them with rationally founded therapeutic measures. Their occurrence is so frequently

due to the presence of severe anatomical changes of the corresponding organs (cardiac disease, aneurisms, atheroma, gastric ulcer, carcinoma, etc.), or it is often so difficult to differentiate them with certainty from such processes, that some uncertainty in therapeutics is readily explicable, and we generally restrict ourselves to palliative measures. Hitherto electricity has been applied, but timidly to these affections, in part, because we do not know, as a rule, whether the neuralgia is located in the sympathetic, cerebral, or spinal nerves, whether it is of peripheral or central origin, etc.

If a conclusion has been reached with regard to the diagnosis, electricity may be employed as our chief antineuralgic, and this must be done according to general principles, while the method of application will undergo various little modifications according to the location of the diseased nerve, and the views concerning the real site of the affection.

According to the most recent statements of Jurasz, neuralgia of the pharynx and larynx occurs very rarely; much more frequent are the hyperæsthesia and paræsthesia of these structures, which yield to similar therapeutic measures. If you have convinced yourself of the absence of all grosser changes in the pharynx and larynx, or have employed ineffectually the customary local remedies, a trial of electricity is certainly justified. Various methods may be tried in succession; transverse conduction of a stable galvanic current through the larynx and pharyngeal region, or a stable current from the neck to the angle of the lower jaw and to the larynx; or the stable application of the An to the larynx (Ca upon an indifferent point, for example, the dorsal vertebræ). The faradic current may also be employed in a similar manner with moist electrodes; a still more vigorous effect may be expected in many cases from the application of the faradic brush to the laryngeal and pharyngeal regions, and is especially advisable in hysterical and hypochondriacal hyperæsthesia and paræsthesia. An endopharyngeal or endolaryngeal application of the current cannot be made in such cases.

Neuralgia of the cardiac nerves (angina pectoris) occurs much more frequently and appears in many cases under the marked form of a true neuralgia. But it is very difficult to determine how much is due to purely sensory irritation and how much to coincident motor irritation, whether the latter is produced in a direct or reflex manner, whether the affection is located in the pneumogastric or sympathetic, etc.

Those forms and attacks will be special objects of electrical treatment in which the neuralgic symptoms occupy the foreground, although the recent observations of Ziemssen (*vide* page 227) also render it probable that we may affect the cardiac movements directly. The existence of a disease of the heart or great vessels does not exclude a trial with electricity, since a judicious application of the latter will not do any harm, but may perhaps exercise a palliative effect.

The most varied forms of application of the electrical current have been employed hitherto. Duchenne first used the faradic brush as a strong cutaneous irritant; he faradized the cardiac region and especially the nipples with strong currents and, in a number of cases succeeded in cutting the attack short at once; in a few instances he produced recovery of the disease by the continued application of this measure.

108. *Observation by Duchenne. Idiopathic angina pectoris.*—A tanner, aged fifty years, previously healthy, suddenly noticed (November 1852) a deep-seated burning in the mammary region and radiating pains in the left arm, associated with formication in the latter; palpitation of the heart, oppression, feeling of terror, patient bent over forward; relief from venesection at the end of eighteen hours. These attacks recur upon the slightest provocation, with every movement or excitement. Gradual diminution of the number and violence of the attacks, but the patient was compelled to remain almost absolutely quiet. Every movement, merely bending over, will produce an attack; violent pain with a feeling of constriction under the lower part of the sternum, radiating into the left arm; pain increased on walking. Respirations short; violent palpitation; profuse perspiration; expression of great terror in the face, etc. Attack lasts eight to ten minutes. At the beginning of such an attack (April, 1853) the strongest possible faradic current is passed through the nipple by means of two metallic electrodes. With the terrible pain produced in this manner, the violent thoracic pain disappeared at once and the patient was forthwith in his normal condition. It now became much more difficult to produce another attack; when this did occur finally, it was also checked at once by electro-cutaneous irritation of the upper sternal region. Considerable improvement on the following day; more marked exertion is required to produce an attack, which can be checked in two or three seconds by farado-cutaneous irritation of the thorax. After this day no further attacks occurred; after four to five more applications (within two weeks) the patient was again able to work.

Less trust should be placed in direct faradization of the cardiac region with large electrodes (transversely from the heart to the dorsal vertebræ), or in faradization of the pneumogastric and sympathetic in the neck, including the cervical spinal cord.

On the other hand, Eulenburg looks for especially favorable results from the galvanic current, which may also be employed in various ways. First, the stabile application of the An directly upon the cardiac region and the region of the cardiac plexus (with a large flat electrode), the Ca being placed opposite upon the dorsal vertebræ. Eulenburg places the An on the sternum, the Ca on the lower cervical vertebræ. Then we may endeavor to affect the large nerve-trunks (pneumogastric, sympathetic) lying in the neck, either by placing the Ca upon the cardiac region and the An upon these nerves, or by ordinary galvanization of the sympathetic, or by the ascending current passing from the lower to the upper cervical ganglion of the sympathetic (from which method Loewenfeld recently has reported favorable results). At all events, it appears to me to be important to in-

clude in the treatment the cervical cord in its entire extent, not less also the medulla oblongata. Galvanization of the sympathetic is also successful at times in the so-called vasomotor angina pectoris, as illustrated by the following case :

109. *Observation by Huebner. Angina pectoris.*—A man aged forty-seven years. Suffered from dyspepsia and a feeling of tension in the cardiac region after an exhausting drive. A few days afterward (March 16th), the first violent attack of angina pectoris, followed during the next week by one to four attacks daily, some of them very violent and lasting three hours ; ordinary remedies of no avail. March 25th, first galvanic application ascending to the cervical sympathetic, then the Ca to a few painful points on the back, and labile and stabile upon the cardiac region, the An being placed over the third ganglion. After this sitting the attacks ceased and have not since returned.

The strength of the current must be chosen with a certain amount of caution ; like the duration of the sitting, it should be increased very gradually. Eulenburg advises that active irritation of the skin should be avoided in those cases in which symptoms of irritation of the pneumogastric and paralysis of the vessels are manifested from the beginning. Recently, in a very severe case of angina pectoris, I observed at least favorable palliative effects for a number of months from galvanization of the neck and directly over the heart.

As in angina pectoris, so also in neuralgia of the nerves of the stomach (cardialgia or gastralgia) we are equally uncertain whether the affection is located in the pneumogastric or sympathetic and whether it is due to organic changes in the stomach (ulcer, beginning carcinoma, etc.) or not. Leube has therefore recommended electricity as an aid in diagnosis. However, there are not a few cases (in hysteria, neurasthenia, chlorosis, etc.) in which the purely nervous character of the affection is not doubtful for a moment, and in which a trial of electricity appears indicated. Leube applies the An to the epigastrium, especially to its most painful part, the Ca in the left axillary line or more toward the spinal column, and allows a strong stabile current to pass for five to ten minutes. Vizoli has recently cured a very severe hysterical gastralgia by the application of the An (Ca in the hand).

110. *Observation by Leube. Gastralgia.*—A man, aged forty years. A vegetarian ; suffered for three weeks from pressure in the epigastrium, alternating with pain which extends to the back, disappears in the recumbent position and, when very severe, is associated with hiccough. Eating has no effect ; appetite good ; no vomiting. A tender, painful point as large as a dollar in the region of the stomach. Diagnosis uncertain between ulcer and gastralgia. Galvanic treatment ; An upon the painful spot in the epigastrium ; the violent pain disappeared at once. The same effect is produced by each repetition of the galvanization ; recovery in a few weeks.

Treatment of the spinal cord or of the sympathetic and pneumogastric in the neck may be employed to advantage. Beard recommends especially his "central galvanization" (*vide* page 118) as a sovereign remedy against nervous cardialgia. As a matter of course, direct faradization of the gastric region or the faradic brush to the epigastrium is also allowed or indicated.

Neuralgia of the intestinal nerves (enteralgia, colic) presents the same characteristics as gastralgia; very little has been determined hitherto concerning its treatment by electricity. It is difficult to differentiate purely nervous colic from the other forms which are due to disease of the intestines, foreign bodies, worms, etc. Electrical treatment is chiefly indicated in hysterical individuals, while the most frequent form of colic, viz., lead colic, yields, as a rule, so readily to other measures that the former is unnecessary.

If, however, you desire to make a trial of this plan, the An should first be applied stable to the abdomen, upon the specially painful parts or upon the region of the celiac plexus and abdominal aorta, with a large flat electrode; the An may also be applied to the spine in the region of the splanchnic nerves, sixteenth to twelfth dorsal vertebræ, the Ca upon the abdomen, with quite a strong current.

These points of application are also advisable for the faradic current, which is introduced by means of moist electrodes; the integument of the abdomen, especially the epigastrium and groins, is the most suitable point of application for the faradic brush or moxa.

In lead colic it has been recently recommended to produce an evacuation from the bowels by means of strong faradic currents and thus to cut short an attack of colic (one electrode introduced into the rectum and the other passed over the entire surface of the abdomen).

111. *Observation by Rothe. Lead colic.*—A type-setter, suffering for six days, from violent lead colic with complete obstipation. Injections of morphine and the strongest drastics were useless, as were also copious enemata of soap and water. Treatment: a wire-shaped rectal electrode was introduced as far as possible, the other broad sponge electrode applied labile to the abdominal walls and lumbar vertebræ for eight to ten minutes with a strong faradic current. After this application the pains disappeared almost entirely; a few minutes later an enormous evacuation from the bowels occurred with relief from all the symptoms.

Finally, mention must be made of the not very rare neuralgias in the distribution of the pelvic nerves, among which may be included an entire series of painful affections which are known under different terms, such as hypogastric, uterine neuralgia, hysteralgia, dysmenorrhœa, spermatic, urethral, ano-vesical neuralgia, etc.; certain cases of vaginismus and ovarian hyperæsthesia may also be included in this class. These maladies have not been studied sufficiently by electro-therapeutists, still less by gynecolo-

gists, in whose department these morbid processes usually fall, although considerable good may probably be effected in these diseases by electrical treatment. Neftel has made an attempt recently to investigate this subject from a general standpoint and describes a method of galvanic treatment to which he attributes excellent results. He calls it "galvanization of the genito-spinal centre and of the splanchnic nerves," starting from the hypothesis that the therapeutic results are mainly due to the action upon these parts. The following is the method: the An is applied to the back over the lumbar enlargement, the Ca in the middle of the hypogastrium, immediately above the symphysis; a few changes of polarity are first made, then the strength of the current is diminished and the An slowly passed up and down along the entire spinal column; the same procedure is then repeated with a stronger current; then the Ca is placed first upon one, then upon the other inguinal region and a similar application of the An made, with repeated changes of polarity. This vigorous method is said to be specially adapted for violent attacks of dysmenorrhœa and the pains are at once removed or at least ameliorated. After the cessation of menstruation, it is continued for a long time (one to three months) with milder currents. A similar plan with the appropriate change in the points of application is also recommended by Neftel for the remaining visceral neuralgias; he cautiously adds, however, that changes of polarity and strong currents were not well tolerated by hysterical patients. Holst has also treated a case of dysmenorrhœa in this manner with favorable results. As a matter of course, pregnancy constitutes a counter-indication.

The attempt may also be made to relieve these neuralgias with the faradic current by the two usual methods of application. Heinlein rapidly relieved a spermatic neuralgia by feeble faradic currents (electrical hand).

Von Holst has employed recently the galvanic current with success against ovarian hyperæsthesia, one pole (which?) being placed upon a painful point on the spine, the other upon the sensitive ovary.

Under the term "rectal neuralgia" Neftel has described certain conditions characterized by great pain and disagreeable sensations in the rectum, which occur after each act of defecation and may continue many hours, nothing abnormal being found on physical examination; he has also treated this affection successfully by the method above described. A similar condition may also occur in the bladder and urethra after urination.

VL SPASM AND CONTRACTURE.

LECTURE XXVII.

Introduction: Character and Pathogenesis of Spasms; the Spastic Change—The Electrical Irritability—Electro-therapeutic Objects: Relief of the Direct Motor Irritation; Removal of Reflex Stimuli; Production of Vigorous Inhibition; Cases—Electro-therapeutic Methods; Causal Treatment; Direct Antispastic Treatment and its Methods; Galvanic and Faradic; General Plan of Treatment; Results—Individual Forms of Spasm: Spasms of the Muscles of Mastication; Mimic Facial Spasm; Blephorospasm; Spasm in the Distribution of the Spinal Accessory and in the Neck; Spasm in the Muscles of the Trunk; Respiratory Spasm, Singultus, etc.; Spasms in the Upper and Lower Limbs.

In turning to the consideration of the electro-therapeutics of spasms, I enter upon a field which presents certain analogies to the neuralgias, but is much more difficult and complicated than the latter. The study of convulsions constitutes one of the darkest chapters in the pathology of the nervous system, and in very many of the remarkable affections belonging to this category we are entirely ignorant of the situation and character of the primary lesion of the nervous system and of the pathogenesis.

Our treatment of these affections, accordingly, is also based upon a very uncertain foundation; the results are sometimes unexpectedly good, sometimes equally unexpectedly negative, and, at all events, the electro-therapeutic success is much inferior to that obtained in neuralgias. We must, therefore, enter upon this field with a cautious reserve, as there is much room for exact therapeutical investigations.

We will devote, at the onset, a brief consideration to spasm in general, and then to those cases in which more or less localized spasms have acquired a certain independence and appear as distinct maladies, or those in which such local spasms are merely part-symptoms of grosser local diseases of the nervous system. I will reserve for consideration in subsequent lectures those forms of spasm which have been introduced into neuro-pathology as so-called general neuroses, or also as central (functional) neuroses (chorea, epilepsy, tetany, paralysis agitans, etc.).

A brief review of the nature and pathogenesis of convulsions is necessary as a foundation of electro-therapeutic methods. If we define them as "involuntary muscular contractions, produced by pathological processes,"

expression is thus given to the fact that abnormal irritative processes—abnormal either from their mere occurrence or their intensity—have occurred in the motor apparatus in the widest sense, viz., the muscles, motor conducting paths, motor and reflex centres. In the majority of cases, however, we know absolutely nothing concerning the nature of the nutritive or histological changes in these parts, which have either produced the abnormal irritative process or constantly accompany it. The most superficial consideration teaches that the spasm is not produced by gross anatomical changes, since the latter are always followed by paralysis; and even if we find, as is not infrequently the case, gross anatomical lesions in spasmodic diseases, we may always assume, with some degree of certainty, that they have not affected the motor apparatus itself, but are found in its vicinity, and thus exercise an irritant effect upon it. If spasm and paralysis are associated in the same motor tract, it must be assumed that the cause of paralysis is situated in a more central portion of the path of conduction than that producing spasm. We are therefore forced to the conclusion that spasms in general cannot be due to severe anatomical lesions, but that we have to deal mainly with finer (molecular, nutritive, circulatory) changes which may be produced, it is true, in various ways. And if we consider carefully the relations of certain spasms to their cause, the view is forced upon us that these causes frequently do not produce directly the morbid irritation in the nerves which gives rise to the spasms, but that the latter are induced by a special and peculiar change in the motor apparatus, a sort of "spastic change," analogous to the previously mentioned "neuralgic change," and that this constitutes the real nature of the spasmodic affection and produces the individual spasms. But these are merely more or less plausible surmises.

With regard to the pathogenesis of these pathological stimuli we may say that they owe their development either to an abnormal intensity of the stimulus or to increased excitability of the motor apparatus. In very many, perhaps the majority of cases, it will not be possible to separate sharply these two factors, and not infrequently they will be associated with one another. But at all events it is more probable that the increased excitability plays a more important part in the pathogenesis of convulsions than the increase in the intensity of the stimulus, and that what I have just described as "spastic change" of the motor nerves may not differ very greatly from such an increased excitability. But we still possess no knowledge as to what the character of this irritative process must be in order to produce the various forms of convulsions (tremor, spasm, tetanus, contracture, clonic convulsions, etc.).

The abnormal irritative process may act directly upon the motor apparatus, as upon the muscular fibres themselves and the motor terminal plates (fibrillary contractions, certain forms of contracture), or upon the peripheral paths of conduction (from neuritis, injury, etc.), or upon the

motor paths of conduction and the central apparatus of the spinal cord included in them (in myelitis, spastic spinal paralysis, etc.), or, finally, upon the brain (apoplexy, tumors, inflammation, etc.) in various parts, from irritation of the conducting-paths as well as the centres. In illustration of this I will merely mention Nothnagel's convulsive centre in the pons and the recent experiments upon the cerebral cortex.

On the other hand, the irritative process in spasms is not infrequently produced indirectly, most frequently in a reflex manner, either by an abnormal condition of irritation in the sensory terminal apparatus and paths (as in disease of the sensory nerves themselves, in irritation of surfaces rich in nerves, the skin, mucous membranes, retina, etc.), or by an abnormally increased irritability of the reflex centres in the spinal cord and brain, which will convert the normal physiological stimuli into spasmodic centrifugal irritations (as in myelitis, tetanus, etc.).

To what extent, finally, the inaction of inhibitory mechanisms may be made responsible for the pathogenesis of convulsions, will not be considered closely, since our previous knowledge of the situation, character, and mode of action of these mechanisms would be insufficient to exert a decisive influence upon our electro-therapeutic measures. I will merely add that the existence of a general neuropathic disposition or affection will aid considerably in the production of spasms, even of many local ones, and that without such a favorable predisposition very many local spasms would not be produced by certain exciting causes. This is true of a general neuropathic taint, of hysteria, neurasthenia, anæmia, chlorosis, and perhaps of other conditions which enfeeble the nervous system; this feature must be carefully considered in treatment.

This is naturally not the place to enter, even in brief, upon the symptomatology and diagnosis of individual forms of spasm. But I will not omit to state that, for a successful therapeutics and the development of therapeutic indications and methods, it is indispensable to obtain the most accurate knowledge concerning the neuro-muscular tracts affected by the spasm (very grave errors not infrequently occur, for example, in mistaking the side of the body affected by the spasm, as in spasm of the muscles of the throat and neck); to endeavor to ascertain, as far as possible, whether the spasm is produced in a direct or reflex manner; to determine, in the first event, the exact site of the lesion with all our diagnostic aids; in the other event, to determine with great care the sensory nerve tract from which the morbid irritation proceeds. In this respect I will remind you especially of the spasm-producing or spasm-inhibiting pressure-points discovered by Graefe, Remak, and others, and which possess such great importance in electro-therapeutics.

Unfortunately I am compelled to say that electrical examination has hitherto contributed little or nothing to the elucidation of these important points. In very many, especially in pure cases, no change is discovered

in the electrical excitability ; in complicated cases changes occasionally occur which are connected with the accompanying paralysis and have nothing to do with the spasm as such. There is no change which is peculiar to spasm, and even with a careful qualitative examination there are very few cases in which we can detect the anomaly which is most to be looked for, viz., increased electrical excitability. This has been observed with great regularity in tetany since the change was first pointed out by me ; I have been unable to corroborate this observation with regard to chorea. At all events, other and finer methods of examination are necessary in order to determine any changes which may be characteristic of spasm. The apparent diminution of electrical excitability, which is found not infrequently in contracted neuro-muscular tracts, because feeble stimuli cannot find any expression in the already contracted muscles, must not be regarded as a real diminution. It is occasionally possible to demonstrate points of pain and pressure by means of the electrical examination ; in difficult cases this examination should not be omitted (Ca upon the spine, the plexus, etc.).

After these introductory remarks you will have formed some idea of the objects to be effected by electro-therapeutics. In the first place, the removal of the direct motor irritation ; this may be done by diminution of the excitability, by anelectrotonus of the motor apparatus, *i.e.*, by the modifying effects of electrical currents ; or by the removal of pathological irritants from the neighborhood of the nerve (congestion, inflammation, cicatrices, etc.), for which purpose the vaso-motor and catalytic actions of the current are resorted to ; or we endeavor to utilize both categories of actions, in order to abate the hypothetical molecular or nutritive disturbance in the motor nerves, the spastic change.

The second object consists in the removal of the reflex irritants producing the spasm ; these should be treated in the same manner as neuralgias and other conditions of sensory irritation, *i.e.*, by means of the modifying and catalytic actions of the current ; to this category belongs also the treatment of certain pressure points, which is so useful in many cases.

Finally, we still possess another means of relieving convulsions, viz., by the production of vigorous inhibition, by which the motor irritative process is suppressed ; this is done by the aid of strong peripheral sensory irritation, *i.e.*, by the stimulating action of the current.

You will soon learn that this latter method is also occasionally available for the production, by means of over-stimulation, of a sort of exhaustion of the motor apparatus, and also in order to relieve secondary nutritive disturbances (shortening, atrophy, etc.) which develop occasionally in muscles that have long been the site of spasm.

It also goes without saying that the most varied actions of the current may be utilized in meeting the causal indication, *i.e.*, the removal of

the primary affection which has given rise to the spasm, such as neuritis, myelitis, gray degeneration, hysteria, neurasthenia, etc. This coincides not infrequently with the direct antispastic treatment.

Despite the numerous aids with which the electrical current seems to furnish us, the electro-therapeutics of convulsions presents much greater difficulties and uncertainties than that of neuralgias. The results are by no means so brilliant and certain, and often depend more upon chance than upon the skill of the electro-therapist.

However, literature and practical experience furnish numerous examples of favorable results from the electrical treatment of the most varied forms of spasm. The following cases will serve as illustrations of the difficulties of treatment, as well as of the different methods of electrical application.

112. *Personal observation. Left facial spasm (convulsive tic).*—A man, aged forty-eight years. Suffering for ten days from mimic facial spasm of the left side, occurring in numerous typical attacks; it developed suddenly without known cause. Galvanic treatment: An stable upon the pes anserinus, stabile from the nerve-trunk to the muscles; later, galvanization of the sympathetic. After twelve sittings the affection grew somewhat worse. Treatment then intermitted for two months, slow improvement, eight to ten attacks daily. Galvanic treatment then resumed; in the next ten days attacks increased to twenty-five a day. Then injections of morphine for a month without effect. Then application of increasing faradic currents; after the fifth sitting, attacks reduced to five or seven per diem; after the twelfth sitting three attacks occurred during the next few days, and they then ceased entirely.

Patient remained well for two years; in March, 1870, it reappeared, twenty to thirty attacks daily. Treatment was now begun with increasing faradic currents; no improvement in the next six days. Then galvanic treatment with An stabile; disease grew worse after fifteen sittings. Then increasing faradic currents again; stationary after ten sittings. Then iodide of potassium for three weeks, then bromide of potassium; improvement; six to seven attacks daily. Increasing faradic currents were again employed during fourteen sittings, with no result. After administration of large doses of valerianate of zinc the spasm ceased at the end of two weeks.

January, 1873, disease reappeared; three to six attacks daily. Various methods of electrical treatment had no noteworthy effect.

113. *Personal observation. Bilateral mimetic facial spasm (blephorospasm).*—A man, aged twenty-four years. Suffering for three months from marked winking, associated with a burning sensation in the eyes and photophobia; gradual increase to violent facial contractions. The affection had been improved by ophthalmological treatment. Status on November 16th, 1870: frequent attacks of bilateral mimic facial spasm; first, repeated vigorous contraction of the orbicularis palpebrarum, then opening of the eye, vigorous spasmodic contraction of the frontal muscles and those around the mouth. Attacks occur every two or three minutes. Galvanic treatment: An stabile to the eyes (Ca in the neck), then An stabile to plexus anserinus on both sides. Considerable improvement on following day; cured after fifth sitting.

March, 1873, patient returns with same affection, which had begun three months previously, after a long walk in the snow; attacks not so violent as formerly. Galvanic treatment (same as before) produced recovery in two sittings.

114. *Personal observation. Left mimetic facial spasm.*—A woman, aged twenty-three years. Was operated upon in 1866 for strabismus of left eye. In spring of 1867 twitchings of left side of face began, and gradually increased in severity, especially during excitement. The spasm affects chiefly the muscles around the left eye and in front of the superior maxilla.

November, 1867. Galvanic treatment; An stabile on the plexus anserinus and behind the ear. Considerable improvement after thirty sittings, and final recovery.

115. *Observation by Moritz Meyer. Clonic spasm of the facial muscles.*—A man, aged thirty years. For several months gradually developing right mimetic facial spasm, especially in the orbicularis palpebrarum and the muscles in front of the ear; many attacks daily. Pressure upon small painful swellings over the transverse processes of the third and fourth cervical vertebræ (on the right side) checked the spasm at once. Galvanic treatment: application of An (ten elements) to these spots; almost complete recovery after thirty-seven sittings. After an attack of pneumonia a relapse occurred, but was entirely cured in twenty-three sittings.

116. *Personal observation. Spasm of the right splenius muscle.*—A woman, aged forty-five years. Suffering from this spasm for three months as a result of great excitement. It was preceded by rheumatoid pains in the occiput and neck; the head always drawn to the right side; sleep disturbed thereby; no relief from injections of morphine. Careful examination showed that the spasm affected the right splenius muscle. It occurs especially during movements; interferes with work; now ceases during sleep. Patient anæmic, otherwise healthy. Galvanic treatment: An stabile upon the muscle and the neck on the right side, then stabile transversely and obliquely through the head. Distinct improvement after four weeks' treatment, but no further progress thereafter. Faradic currents of increasing strength are then tried; considerable improvement in three weeks; spasm, in a mild degree, only occurs while walking.

117. *Observation by E. Remak. Spasm of the neck muscles.*—A woman, aged fifty-two years. Suffering nearly three years from very severe spasms of the neck muscles (chiefly in the distribution of the right spinal accessory, but also in the splenius, biventer, etc., together with spasmus nictitans and spasmodic rolling movements of the eyeballs). Patient had been cured of a similar affection seventeen years previously by galvanization of the right transverse processes of the cervical vertebræ. Then remained well for fifteen years. Recent galvanic treatment had no effect. But a favorable result was again obtained by anodal applications to the right transverse processes of the cervical vertebræ with a moderately strong stabile current; very marked improvement was effected in eighty-four sittings.

118. *Observation by Moritz Meyer. Clonic spasm of individual neck muscles.*—A woman, aged twenty-six years. Suffering for a long time from spasmodic movement of the head to the left and posteriorly, associated with creaking in the region of the lower cervical vertebræ and various spasmodic twitchings in the limbs. Examination showed abnormal tension of the muscles in the left upper part of the neck; transverse processes of middle cervical vertebræ on left side tender on pressure. Spasm almost constant, very distressing. Treatment: stabile application

of An to left upper part of neck, Ca in the submaxillary fossa, for ten minutes, an assistant with difficulty holding the head. In four weeks the patient could hold the head in normal position without assistance for a few seconds; after one hundred and seventy-five sittings improvement so far advanced that patient could go to a watering-place. Later recovery.

119. *Observation by Erdmann. Rheumatic torticollis.*—A merchant. Suffering for four months from rheumatic torticollis; head turned to the right, forward and downward, chin approximated to right shoulder. Passive movements painful. Faradic brush to neck rendered movements of head more free for several hours. This, together with direct faradic stimulation of left splenius produced recovery in ten sittings.

120. *Observation by M. Rosenthal. Rheumatic torticollis.*—A woman, aged thirty years. Suffering, as the result of exposure, from contracture of the right trapezius; head drawn to the right and backward, chin turned to the left. Passage of galvanic current through the muscle produced more free mobility of head. Recovery after second sitting.

121. *Observation by Moritz Meyer. Rheumatic contracture of the levator anguli scapulae.*—A girl, aged twelve years, as the result of a cold, was affected with contracture of left levator anguli scapulae, the belly of which was very distinct. Immediate relaxation after passage of current with a few changes of polarity. Complete recovery after third sitting.

122. *Personal observation. Nervous pertussis.*—A girl, aged twelve years. Has had spasmodic attacks of coughing for six months, occurring every few seconds as a hoarse, toneless cough, associated with slight twitchings in shoulders and lips; complains of pain in laryngeal region, Also suffers from migraine.

Faradization of larynx for two days; disappearance of pain, but cough unchanged. Then galvanic treatment: stabile, transversely through the larynx and from neck to larynx. Very rapid improvement; cough disappeared in five days. Patient returns home and disease reappears in few days. Comes under treatment four weeks later; after four days cough disappeared under galvanic treatment, which was continued a few weeks; recovery.

123. *Observation by M. Meyer. Singultus, with weakness of the left arm.*—A very nervous man, aged forty years. Weakness of left arm, sixteen years ago, after severe exertion, associated with feeling of constriction in left side of thorax and frequent eructations. Pressure on spinous process of seventh cervical vertebrae produces pain and violent singultus, occurring about twenty times every half minute; transverse processes of third to fifth cervical vertebrae also tender on pressure. Anodal treatment of these points produced improvement forthwith, and almost complete recovery after nine sittings.

124. *Personal observation. Spasm of both recti abdominis and latissimi dorsi.*—A woman, aged twenty-four years, very anæmic. Suffering for a year and a quarter from spasmodic twitchings in the abdomen, painless, but increasing in frequency and severity. Frequent intermissions lasting several days. Examination shows isolated, short, lightning-like contractions in both recti abdominis with synchronous but weaker contraction in both latissimi, and slightly also in the pectorales majores. The spasm produced by pressure and a slight blow upon the abdomen. No indications of hysteria. Stabile passage of galvanic currents from the dorsal spine to the epigastrium produces a noteworthy improvement.

125. *Observation by Moritz Meyer. Tremor of the right arm.*—A boy.

aged fourteen years. Suffering for two years from gradually increasing tremor of the right arm. Stable galvanic current, ascending from the radial nerve to the plexus, labile galvanization of the extensors in the forearm. Distinct improvement after three sittings; recovery after nineteen sittings.

126. *Personal observation. Clonic spasm of the lower limb as the result of an articular neurosis.*—An officer, aged twenty-eight years. Nervous temperament. July, 1866, struck by a spent ball upon inner side of left tarsus; inflammation and swelling of the entire leg, followed by pain and tenderness in left knee, in which a traumatic inflammation had been present fourteen years previously. Pain prevented patient from walking or standing upon left foot. Later, twitchings in muscles of calf and thigh, more violent upon flexion of the knee; sleep disturbed by twitchings.

August 30, 1866: left leg stiff; knee-joint slightly swollen, very tender on contact; fibrillary and clonic contractions in calf and thigh, much more vigorous upon touching the patella and upon every attempt at flexion. Galvanic treatment: An stabile upon the knee-joint for two to three minutes, then descending stabile through the crural and sciatic nerves for three to four minutes, later through the lower part of spine. Discharged cured after eighteenth sitting.

127. *Observation by R. Remak. Hemiplegic contracture.*—In a patient suffering for two years from hemiplegia and contracture, a primary faradic current was passed through the contracted flexor of the forearm; immediately afterward the hand could be opened passively and the fingers extended. In the same patient relief of the contracture was obtained in a remarkable manner by the application of descending galvanic currents through the nerves of the contracted flexor muscles. Voluntary power over the paralyzed muscles increased at the same time.

128. *Observation by R. Remak. Rheumatic contractures.*—A woman, aged forty-nine years. Suffering for seventeen years from chronic articular rheumatism of the upper limbs; contracture of the flexors from the shoulder to the hand. A galvanic current was passed for six minutes through the muscles of the right shoulder and arm. Forthwith the patient raised the arm higher than she had been able to do for the past seventeen years. On the following day the patient reports continued improvement. Muscles of forearm and hand treated in same way with similar result, and this was afterward obtained in left arm.

129. *Observation by Baerwinkel. Contracture in compression-myelitis.*—A boy, aged six years. Suffering from paraplegia due to caries of the vertebrae; presented paralysis and anæsthesia of the legs, greatly increased reflexes, flexor contracture at the knee, extensor contracture in the foot. Strong galvanic current, stable from the upper surface of the kyphosis to the coccyx produced immediate relaxation in the joints of the foot so long as the circuit was closed and for a few moments thereafter. Knee and hip joints were not affected thereby.

130. *Observation by Leloir. Hysterical contracture.*—A woman, aged twenty-two years. Suffers from anæsthesia of left hand and forearm, left ovarian hyperæsthesia, and a hysterical contracture of left hand, which had lasted two months; the latter was cured in eleven days by permanent application of a feeble galvanic current of five to ten elements daily for six hours.

131. *Observation by Moritz Meyer. Reflex contracture of the quadratus lumborum.*—A man, aged thirty-three years. Suffering since February,

1879, from weakness of left knee and ankle joint ; also swelling of left hip and dorsal muscles. Slow improvement, then relapse, curvature of spine to left, so that an iron corset and cork sole in right shoe became necessary. Scoliosis of lower dorsal and lumbar region appears due to very firm contracture of left quadratus lumborum. Passage of galvanic current through the muscle had no noticeable effect, but this occurred at once upon application of one pole to the quadratus, the other to the sacrolumbalis, with changes of polarity of a strong galvanic current (forty to fifty elements). Improvement was striking, and the scoliosis had disappeared almost entirely after fourteen sittings.

In the selection of the electro-therapeutic method the removal of any palpable lesion of the nervous system, which may be present, must first be thought of, *i.e.*, the causal indication must be met. This is done by the electrical treatment of any demonstrable organic disease of the brain, spinal cord, or peripheral nerves, according to well-known methods. There can be no doubt that such procedures are often attended with good results, and it is a pity that in so many cases a causal affection cannot be demonstrated with certainty.

As a rule, the direct antispastic actions of the current must be resorted to, but you will often be embarrassed as to the position in which the electrodes should be applied—whether upon the muscles themselves, the peripheral motor nerves, spinal roots of the nerves, spinal cord or brain, or, indeed, upon remote parts, points of pressure, sensory nerves, etc. We are not often in a position to decide this question with any degree of probability, and we must then make systematic experiments until the proper locality has been found.

The individual methods of antispastic treatment coincide, in the main, with those of antineuralgic treatment. The galvanic current, especially the stabile application, is mainly employed for the production of modifying and catalytic effects upon the motor nervous apparatus. The anode is placed upon the nerve-trunk (or the spinal cord or brain, or whatever point you desire to influence) and allowed to act stabile for some time, beginning with a very feeble current, gradually increasing, and, after remaining at this degree of intensity for some time, gradually diminishing it. If the anodal application is ineffectual, trial may be made of the cathode in the same manner, as this possesses, perhaps, other catalytic actions. Descending stabile currents through the motor nerves act in a similar manner, but the ascending current is said to be more efficient at times ; furthermore, R. Remak states that he has had similar favorable results from frequent interruptions of a descending current passing through the nerves and muscles, especially in tonic reflex spasms. The fact observed by Ranke, that galvanic currents of a certain intensity, when passed through the spinal cord, inhibit the reflex spasms of strychnine poisoning, perhaps has its analogue in the favorable results obtained in man by Baer

winkel (*vide* Observation 129). The direction of the current appears to be immaterial if its strength is sufficient.

Antispastic effects may also be produced by the faradic currents, either by passing feeble faradic currents (with moist electrodes) through the motor apparatus, perhaps also through the head and spine; or by strong faradic currents through the peripheral nerves and muscles. Starting from the physiological fact that the dilatibility of the muscles increases while they are being strongly faradized, Remak first employed such currents, with success, for the relief of paralytic contractures. The application of gradually increasing and diminishing faradic currents is probably the best method of producing such effects.

It has not been ascertained whether these procedures act by overstimulation and consequent exhaustion of the motor apparatus, by a change in the nutritive processes, or by diminution of excitability.

A second method of treating convulsions is the removal of peripheral irritants in so-called reflex spasms. Recourse is had to the methods customary in neuralgia and other conditions of sensory irritation, *i.e.*, mainly to the application of stable galvanic currents, etc., upon the sensory nerves. To this category also belongs the electrical treatment of pressure-points or of sympathetic tracts and ganglia. A stable anodal application should first be made to these points; its action is sometimes exhausted after a certain length of time, and other points must then be sought.

Finally, the last method, which sometimes proves successful, is the production of inhibitory action by means of very severe peripheral irritation; this may be done either by removing sensory reflex irritants (as in neuralgia), or by the direct inhibitory effect of a vigorous stimulus upon motor irritation. For this purpose the faradic brush or the moxa is applied to various parts of the skin in the immediate neighborhood of, or remote from, the affected motor nerves, upon the spinal column, or in the epigastrium; in some cases it is useful to stimulate points of pressure either with the faradic brush or the stable Ca, when irritation of these points stops the spasm.

I will mention in conclusion that, in old rheumatic and other contractures, faradic excitation of the antagonists of the contracted muscles is sometimes resorted to in order to improve the contracture, deformity, and mobility of the parts. It goes without saying that this is merely a form of electrical orthopædics and gymnastics.

In paralytic contractures the treatment of the paralyzed antagonists not infrequently benefits the contracture, since it is evident that the restoration of voluntary power over the paralyzed muscles is the best means of antagonizing the contracture which has resulted in consequence of such paralysis.

It is thus evident that a large number of methods of electrical treatment against spasm are at our command, and it is often difficult to make

a choice. As a matter of course you will select the method according to well-known rules and the peculiarity of the individual case, but you must be prepared for failure and the necessity of trying a number of other methods. As a general plan of treatment I would recommend that a careful search be made for causal affections, and for the true localization of the disease, and that these be made the first point of attack ; furthermore, great care should be exercised in the determination of reflex irritants and points of pressure, since cases in which these are found present more favorable chances for treatment. In the direct treatment I would recommend beginning with the mildest measures, such as stabile anodal application, and then passing to descending stabile currents, simple or increasing faradic currents, then to the faradic brush, and finally to changes of polarity. A method which failed at first may prove beneficial at a later period.

The intensity and duration of the applications depend upon individual circumstances ; it is always advisable to begin with weak currents and short sittings, and gradually pass to more vigorous applications, perhaps repeated several times a day. The duration of the entire treatment must sometimes be very protracted. According to Remak the treatment should be stopped and the complete recovery left to nature after the spasm has been relieved with the exception of slight traces. You should always be prepared for relapses, which occur very readily and frequently, often after very long intermissions.

The results of electro-therapeutics in convulsions are extremely uncertain ; they are sometimes surprising and brilliant, at other times the obstinacy of the affection drives physician and patient to desperation. Hardly any general statements may be made with regard to the prognosis ; rheumatic muscular contractures, and the spasms produced by cold, neuritis, traumatism, and the like are relatively favorable ; especially favorable are reflex spasms and those forms which are associated with distinct points of pressure ; very obstinate are those due to a severe neuropathic diathesis, frequently relapsing spasms, and those occurring in organic diseases of the spinal cord and brain, while functional central spasmodic diseases present a better prognosis.

In the discussion of the individual forms of spasm I may confine myself to a few practical details.

Spasm of the muscles of mastication (in the tonic form as trismus, in the clonic form as gnashing or chattering of the teeth) very rarely occurs as an isolated affection ; more frequently it is a part-symptom of general forms of spasm. The isolated forms occur sometimes from a direct affection of the motor root of the trigeminus, more frequently in a reflex manner (irritative conditions in the distribution of the trigeminus, affections of the teeth, disease of the temporo-maxillary joint, peripheral injuries, worms, etc.). The electrical treatment varies accordingly ; it presents no peculiarities and may be applied in different ways.

The most frequent of all forms of spasm is mimetic facial spasm, or convulsive tic in all its various forms, such as partial or diffuse, tonic or clonic spasm, occasionally also in the form of slight contracture (after facial paralysis). It may arise from various causes; those forms are usually the worst in which no cause can be ascertained and in which the tic persists for years. Peripheral and central diseases have been recognized occasionally as causes; recently the view has been entertained that a portion of the "idiopathic" clonic facial spasms are due to an affection of the cerebral cortex in the region of the so-called facial centre.

The electrical treatment requires judgment and patience; all the various methods may be employed and must be resorted to sometimes in succession, viz., stabile application of the An with increasing and decreasing strengths of current upon the plexus anserinus or upon the trunk of the facial nerve behind the ear; transverse conduction of the current through the mastoid processes (An upon the affected side); stabile application of the An upon the opposite parietal region over the facial centre (lower half of the central convolutions, *vide* Fig. 29, page 122); the "large head electrode" placed upon the well-moistened scalp will serve as the An (Ca upon the spine or the opposite hand), the current being applied stabile, of moderate strength, for five to ten minutes. You may also employ descending stabile currents in the individual nerve branches, or frequently repeated cathodal closures or changes of polarity. If points of pressure are found (upon the spine, in the face, the buccal cavity, behind the ear, etc.) they must be made the subject of anodal treatment; in severe cases do not omit applications to the individual ganglia of the cervical sympathetic, especially if they are tender on pressure.

Increasing faradic currents may also be applied to the nerves, not infrequently with good effect; likewise faradic currents transversely and longitudinally through the head or the cortical centres; finally, trial may be made of the faradic brush applied to the integument of the neck, the posterior auricular region, or to any painful points which may be present.

Partial facial spasm, especially the so frequent blepharospasm, is treated in an entirely analogous manner; anodal application to the closed lids and the region of the supra-orbital nerve, and then, above all, the treatment of points of pressure which play such an important part in these forms; likewise, galvanic treatment of the sympathetic and its individual ganglia.

Spasms of the tongue and of the ocular muscles are very rare and may be treated according to general principles.

On the other hand, spasms in the distribution of the spinal accessory nerve and in the other muscles of the neck are not at all infrequent and are very annoying to the patient. They present the greatest analogy with true convulsive tic, and may be treated in the same manner. This category includes spasms in the sternocleidomastoid, trapezius, splenius,

rotatores capitis, levator anguli scapulæ, and the other deep muscles of the neck and throat, and their symptomatology and diagnosis may be studied in the treatises on neuropathology. The anodal treatment of the neck, spinal accessory nerve, and cervical sympathetic, recently recommended by E. Remak, should be tried first; in addition I apply the anode usually to the cerebral cortex on the opposite side, and an application may also be made to the medulla oblongata (transversely through the mastoid processes). If points of pressure are present, these should first be treated.

Tonic spasms also occur very often in these muscles; they are observed not infrequently in their recent form as rheumatic torticollis, and then offer a very favorable object for electrical treatment (*vide* Observations 120 and 121). A few sittings (An stable or changes of polarity, or vigorous faradization) are usually sufficient to relieve the affection. But this is effected with much more difficulty in the congenital forms, or those which have passed into permanent contracture. In such cases every method is often tried without avail, and, at the most, some good result is obtained from the regular (gymnastic-orthopædic) faradization of the antagonists.

This holds true of spasms and contractures in the other muscles of the trunk (the back and abdomen) which may occur in the most remarkable forms and combinations, and usually present the greatest difficulty even to clinical examination and interpretation. Electro-therapeutics possesses few triumphs among these forms of spasm; their treatment is carried out according to general principles, and consists, in the main, of a more or less premeditated experimentation with the most various methods in all possible parts of the peripheral and central nervous system from which the spasm may proceed.

Mention should be made also of spasms of the respiratory muscles, inspiratory and expiratory spasms, singultus, etc., since they fall occasionally into the domain of electro-therapeutics. These spasms, which are by far the most frequent in hysterical persons, affect either the diaphragm alone or the entire respiratory mechanism, or inspiration or expiration separately, or various expiratory acts, such as coughing, sneezing, crying, laughing, etc. In tonic spasm of the diaphragm, an extremely rare affection, success has been obtained sometimes by the vigorous application of the faradic brush to the epigastrium in the region of the diaphragm; also from faradization or galvanization of the phrenic nerves in the neck. The same method is also adopted in clonic spasm of the diaphragm (hiccough), which is very obstinate and annoying occasionally and demands active treatment. I have seen brilliant results in such cases from the application of the faradic brush to the epigastrium, and others report similar effects from faradization or galvanization of the phrenics; in some cases, anodal treatment of the neck or transverse conduction through the

mastoid processes may prove serviceable ; likewise a vigorous stimulation of the distribution of the superior laryngeal nerve. Electrical treatment is generally useless in the complicated forms of respiratory spasm (inspiratory and expiratory spasm, sneezing, yawning, laughing, crying spasms, etc.). Some good result may be obtained, perhaps, if the causal indication (hysteria, peripheral irritation, ovarian hyperæsthesia, etc.) requires electro-therapeutic measures. The same methods may be employed directly in these spasms as in spasm of the diaphragm.

Spasms in the muscles of the upper limbs are very common ; as a rule, indeed, they usually form part of more widespread forms of spasm and other neuroses (chorea, tetany, hysteria, paralysis agitans, epilepsy, etc.), or they constitute a symptom and sequela of severe local central diseases (as in hemiplegic contracture, post-hemiplegic chorea and athetosis, partial cortical epilepsy, contracture in spinal affections, etc.), and often require no other treatment than that of the primary disease. Sometimes, however, the spasms develop locally in the upper limb, from neuritis of individual nerves, joint affections, neuralgias, etc.

As a matter of course, it is necessary that the primary affection be treated first, and the often-mentioned antispastic methods may then be applied to the nerves and muscles of the arm, to the neck and throat, to painful points in the brachial plexus or the spinal column, etc. ; anodal application to the neck and brachial plexus is the main feature of the treatment. The various methods to which I have previously referred (descending stable galvanic currents, or frequently interrupted galvanic currents or changes of polarity, or vigorous faradization with coincident extension of the muscles, etc.) are employed in idiopathic or secondary contractures. Applications to the cortical centres should be tried in partial clonic spasms due to cortical lesions.

The same statements will hold true, *mutatis mutandis*, with regard to spasms in the lower limbs as with regard to those in the upper. In the large proportion of cases they form part of general diffuse varieties of spasm or they are symptomatic of central diseases, especially of diseases of the spinal cord. Purely peripheral spasms, reflex spasms from diseases of the joints, neuralgias, foreign bodies, etc., also occur occasionally ; very frequently, paralytic and hysterical contractures and the so-called cramps, particularly in the muscles of the calves.

The selection of the method of treatment is based on general principles ; further details are unnecessary.

VII. ANÆSTHESIA.

LECTURE XXVIII.

Character and Pathogenesis of Anæsthesia—Electrical Examination—Objects of Electro-therapeutics; Cases—Methods of Electrical Treatment: Causal Treatment; Direct Treatment of Anæsthesia; Methods with the Faradic and Galvanic Currents; Relief of Secondary Trophic Disturbances; Results—Individual Forms: Anæsthesia of the Trigemini, the Pharynx, and Larynx; Vasomotor Anæsthesia; Hysterical Anæsthesia; Ataxic Anæsthesia.

In the same manner that spasms and their treatment present certain analogies to neuralgia, so anæsthesia possesses intimate relations with paralysis. It is due to similar, very often to identical lesions and its electrical treatment is carried out according to the same principles. But the anatomical and physiological conditions of the centripetal paths of conduction bring it about that we have to deal with relatively simpler therapeutic objects than in paralysis, so that the methods of treatment are correspondingly simpler and more uniform.

Anæsthesia refers to a diminution or abolition of the sensations conveyed to consciousness through the sensory nerves and the nerves of special sense. I now refer in the main to cutaneous and muscular anæsthesia (special sense and visceral anæsthesia will be discussed at a later period). This disturbance of function may be due to a diminution of the irritability of the peripheral or central sensory terminal apparatus or to an inhibition and interruption of the processes of conduction in the sensory nerve tracts (conduction anæsthesia). The latter constitute by far the most frequent and important forms of anæsthesia, and are the almost exclusive objects of electrical treatment.

The occurrence of anæsthesia from an exclusive affection of the peripheral sensory terminal apparatus (in the integument, tendons, muscles, joints, etc.) has not been established sufficiently, since implication of the adjacent finest sensory paths of conduction cannot be excluded, as in the usually slight anæsthesias due to cold (ether spray), heat, caustics (lye, carbolic acid, etc.), ischæmia (vasomotor neurosis), etc.

Nor is the occurrence of anæsthesia from an exclusive affection of the central receptive apparatus established with certainty. It is surmised,

indeed, that this apparatus is situated in certain parts of the cerebral cortex, and we can conceive of an isolated affection of such parts, but it will be difficult to decide in how far the sensory conducting paths immediately adjacent to these cortical centres are implicated in the diseases belonging to this category (cortical encephalitis, softening, hemorrhage, meningitis, poisoning, etc.). But this point possesses no special significance with regard to electro-therapeutics, so long as it can be determined that the affection is situated in the brain or cerebral cortex.

At all events, anæsthesias from inhibition of sensory conduction at any part of its course are much more frequent, and their pathogenesis much clearer. As in paralysis, this inhibition of conduction may be produced by various lesions, either in the peripheral paths of conduction, or within the spinal tracts, or finally by an affection of the paths of cerebral conduction (hemorrhage, softening, tumors, sclerosis, etc.). It is possible and indeed very probable that anæsthesia may be produced by so-called impalpable lesions of these various parts (for example, in hysteria, poisoning, syphilis, etc.).

The symptomatology of anæsthesias need be referred to merely to call your attention to the fact that data with regard to the site of the lesion may be obtained from the distribution of the sensory disorder (confined to the territory of one or another nerve, in a paraplegic or hemi-paraplegic, or finally in a hemiplegic form), and that similar conclusions may be drawn from the more or less complete loss of sensation, from the character and distribution of the paræsthesiæ, and not less from the presence or absence of motor, vaso-motor, trophic and special sense disturbances, neuralgia, etc.

Electrical examination can effect very little toward making a diagnosis. I have mentioned previously that quantitative or qualitative changes in the electrical excitability of the nerve-trunks are unknown in anæsthesias. You will remember, on the other hand, that the electrical current may be employed in recognizing and defining the functional disorder of the sensory apparatus (Lecture X., page 93).

Vigorous cutaneous irritants have always been employed as the chief means of treatment of an affection of the sensory nerves, which renders the integument and other tissues more or less insensible to stimuli. Electrical currents constitute the sovereign remedy against all forms of anæsthesia, because they furnish the best and most convenient method of producing cutaneous irritation of any strength required, without causing any permanent change in the integument.

The objects of electro-therapeutics in anæsthesia can be defined in a few words, viz.: the removal of any affection which inhibits conduction, exaltation of the excitability of the receptive organs, the removal of obstacles to sensory conduction itself, and finally the removal of secondary nutritive disturbances which may be present and interfere with the conductivity of the sensory apparatus.

I may state in brief that these objects can be effected by the catalytic, vaso-motor, modifying, and particularly the irritant actions of electrical currents.

132. *Personal observation. Anæsthesia in the distribution of the left trigeminus nerve.*—A woman, aged forty-eight years. Affected in August, 1870, with fornication of left side of face; no pain, frequent vertigo; recently fornication in palate and tongue, diminution of taste upon left half of tongue; patient otherwise healthy.

December 13, 1870.—Diminished sensibility upon entire left half of face, tongue, and palate; left eye reddened, superficial ulcer of cornea. Taste diminished upon left anterior half of tongue. No disturbance of muscles of mastication. Distribution of facial nerve normal; hearing normal. Galvanic treatment: 6 to 8 elements stabile, transversely through the temples and mastoid processes; 8 elements *Ca labile* over entire side of face. After eighth sitting continued improvement, sensibility better, numb sensation in mouth lessened. After fifteenth sitting taste also improved. Patient then stopped treatment.

133. *Personal observation. Traumatic paralysis and anæsthesia of the left ulnar and median nerves.*—A man, aged twenty-one years. Had luxation of elbow in February, 1872, which was not reduced until sixteen days afterward. Middle of November, 1872, patient presents complete paralysis of ulnar and median distribution to the hand, with marked atrophy and complete *De R.* Sensibility of hand extinguished in distribution of these nerves. At the elbow, eccentric sensations can be produced in the hand by the application of faradic current to median and ulnar nerves; two inches above the wrist, eccentric sensations can no longer be produced in this manner. Treatment: *Ca labile* and changes of polarity in median and ulnar nerves and their distribution.

December 15th.—Sensibility present everywhere, though to a less extent than normal.

January 28, 1873.—Sensibility almost entirely restored; motion unchanged.

134. *Observation by Moritz Meyer. Anæsthesia of the ulnar nerve.*—A man, aged thirty-eight years. Contracted severe "sleep" paralysis of ulnar and middle cutaneous nerves six weeks ago. Complete anæsthesia of ulnar side of forearm and ulnar distribution of the hand; paralysis and atrophy of muscles supplied by ulnar. Faradic applications to skin and muscles. Return of sensibility in five sittings; complete recovery in twelve sittings.

135. *Observation by Vulpian. Lesion of right cerebral hemisphere; left hemianæsthesia, etc.*—A man, aged forty-five years. Had an apoplectic attack two weeks ago; followed by paresis of left side, loss of vision in left eye. The entire left half of the body is completely anæsthetic; taste lost on left side, sight very much diminished on this side; hearing normal. Anæsthesia of left half of palate; loss of muscular sensibility on left side. Treatment: application of faradic brush to a circumscribed portion of integument on dorsal aspect of left forearm. Return of sensibility of hand and anterior surface of thigh after three days. Slow progress of improvement. In four weeks the extensor aspect of forearm has become sensitive, as also its inner surface and that of arm; eccentric sensation returned upon stimulation of ulnar nerve in arm; recovery almost complete.

136. *Observation by Grasset. Right cerebral hemianæsthesia.*—A male patient. Presented complete history of right cerebral hemianæsthesia, with hemiparesis and diminution of taste and vision on right side. Tremor on volitional effort in left upper limb. Treatment: strong faradic brush to external surface of right forearm; no sensation at first, but gradually increasing pricking feeling; from this time on, entire right side again sensitive, vision of right eye almost normal. Diminution of sensibility fifteen minutes later, but distinct improvement still present on following day. Similar results from faradization of right and also of left thigh.

137. *Observation by Leloir. Right hysterical hemianæsthesia.*—A girl, aged thirteen and a half years. Had severe hystero-epilepsy at beginning of menstruation. Six months later, complete anæsthesia and analgesia of right half of body; left ovarian hyperæsthesia; smell and taste markedly, audition moderately, diminished on right side; vision normal. A single application (four minutes) of faradic brush to right forearm produced complete recovery of anæsthesia. Effect permanent.

In the selection of the method of electrical treatment of anæsthesia our main object is the removal of the lesion producing the loss of sensation, *i.e.*, of any neuritis, compression, hemorrhage, myelitis, tabes, cerebral affection, etc., which may be present, not less of impalpable nutritive disturbances, if their exact situation can be determined, or of the general neuroses in which anæsthesia is occasionally manifested.

This part of the electrical treatment is the main factor in many cases, and, in itself, is often sufficient to relieve the anæsthesia.

But the causal indication cannot always be met, partly because we are ignorant of the situation and character of the lesion, partly because it may be inaccessible to electrical treatment. In not a few cases this alone proves insufficient; for example, regeneration may be so far advanced that conduction is indeed possible, but has not really occurred, and a vigorous impulse is needed in order to have it take place. Direct treatment then becomes necessary to relieve the anæsthesia or at least to produce its rapid removal.

The direct treatment purposes an increase or restoration of the excitability of the peripheral (occasionally also the central) terminal apparatus, or a restoration of the conductivity of the centripetal paths of conduction. The former possesses less importance, and usually coincides with the fulfilment of the causal indication; the latter—the restoration of conduction—is the main feature to be sought in the majority of cases.

The methods of securing both objects are almost identical; they consist, in the main, of a sufficiently vigorous, often repeated stimulation of the sensory terminal apparatus and paths of conduction, in order to remove obstructions to sensory transmission by a vigorous process of excitation and thus force the restoration of conduction, and, finally, to make the path open for feebler stimulants, for the natural processes of excitation, by the frequent employment of these paths for artificial processes of excitation.

In anæsthesia the irritation must be applied on the peripheral side of the lesion, and the peripheral terminal apparatus and paths of sensory conduction are always at our command for this purpose. The method for the direct treatment of anæsthesia, therefore, follows very simply, viz., peripheral irritation of the skin, of the sensory nerve-trunks, and, if necessary, of more deeply situated parts, if possible, with such a great strength of the current that a sensation, however feeble it may be, is produced. If this is not effected at once, it may be at a later period, inasmuch as the repeated impaction of the waves of excitation against the obstruction may gradually remove the latter, and render the path free for strong stimuli, and gradually for weaker ones.

In employing the galvanic current, the Ca should be applied stable and labile to the integument and nerve-trunks; also cathodal closures and changes of polarity to secure more vigorous excitation. A very intense irritation is produced by the metallic brush armed with the Ca, but very strong currents are required, and care should be taken that the brush be not kept too long in one place, since blisters are produced very rapidly in this manner.

For this purpose, however, the faradic current is usually employed with the brush or moxa and vigorous, rapidly interrupted secondary currents. The chief method, then, is the application of the farado-cutaneous brush, the skin having been dried by the addition of a powder. Furthermore, the nerve-trunks themselves may be stimulated with moist electrodes, or applications made to the joints, muscles, mucous membranes, and deeper parts. At the onset, the current should be so strong that a slight sensation is produced; this usually increases with rapidity, so that, as improvement progresses, weaker currents will be sufficient.

In this treatment of anæsthesia, however, the surprising fact has been discovered that not alone the directly irritated parts of the skin and the nerve-trunks may recover their sensibility, but that adjacent or even remote portions of the integument are relieved temporarily or permanently, and that anæsthesia of the mucous membranes and joints, even of the special senses, is relieved by simple local faradization of a circumscribed portion of the integument. This is especially true of cerebral anæsthesias (produced either by organic lesions or by impalpable changes) and not less of other forms, mainly hysterical hemianæsthesias, in which the application of the brush to a small part of the skin will often restore the sensibility in toto. Special attention has been called recently to this fact by Vulpian. He found that the daily application of the faradic brush with very strong currents for eight to ten minutes to a small part of the skin of the upper limb (external surface of the forearm) had this favorable effect, and was often more successful than faradization of the entire anæsthetic region. Grasset has shown that this effect may be produced by applications to other parts of the anæsthetic skin, and even to the healthy

side of the body. These facts are probably related to the metalloscopic phenomena of hysterical hemianæsthesia, but their explanation is involved in obscurity.

In some cases, finally, we may be called upon to relieve the secondary trophic disturbances in the sensory nerves, either finer nutritive disorders, such as are caused by inaction, or degenerative atrophy from separation from the trophic centres. The trophic centres of the peripheral sensory tracts are situated in the spinal ganglia; this indication is mainly presented, therefore, in peripheral anæsthesia, and may be met in the same manner as in paralysis (*vide* page 192). Secondary degenerations also occur in spinal anæsthesia; the trophic centres for a part of the conducting paths in question also appear to be situated in the spinal ganglia. It is questionable whether electrical treatment is advisable in spinal anæsthesia.

The results of the treatment of anæsthesia vary extremely, and are influenced considerably by the nature of the primary disease. An entire series of cases, accordingly, is incurable. Great differences are also manifested among the curable cases; in some recovery occurs within a few minutes or after a small number of sittings, or improvement occurs forthwith, but is only temporary, and recovery occurs very gradually. This is especially true of the various hysterical anæsthesiæ, of rheumatic, mild compression anæsthesiæ, etc. In other cases improvement occurs very slowly, as in traumatic paralyse, neuritis, tabes, and other affections of the spinal cord.

Concerning the individual forms of anæsthesia I have very little to add.

Anæsthesia of the trigeminus is one of the most important varieties, and requires careful treatment: the galvanic current to the trunk and branches of the trigeminus, Ca labile or the faradic brush to the integument of the face and the mucous membrane of the mouth and tongue. The electrical current also appears to possess a favorable effect upon the associated hyperæmia of the conjunctiva.

Anæsthesia of the pharynx and the entrance to the larynx occurs very often after diphtheria, and requires especial attention on account of the great danger of "food pneumonia:"¹ intrapharyngeal and percutaneous application of faradic or galvanic currents is indicated, especially upon the region of the superior laryngeal nerve. Jurasz recommends the alternate use of both currents.

In vasomotor anæsthesia it is necessary to treat the vasomotor nerves by methods which will dilate the vessels (*vide* the next Lecture), and also

¹ Pneumonia due to the entrance of particles of food into the lungs.

to make very irritating applications to the anæsthetic integument (*An stabile*, *Ca labile*, faradic brush) ; this form usually yields rapidly to treatment.

In hysterical anæsthesia and hemianæsthesia, in addition to treatment of the central organs, cutaneous faradization should not be neglected ; ovarian hyperæsthesia or tender spinal points, which may be present, should also be treated. Vulpian's method may be tried.

In ataxic anæsthesia and analgesia, treatment of the spinal cord itself is mainly indicated and often proves successful. Very favorable results have also been obtained by the peripheral application of the faradic brush.

VIII. DISEASES OF THE CERVICAL SYMPATHETIC.—VASOMOTOR, TROPHIC, AND ALLIED NEUROSES.

LECTURE XXIX.

Diseases of the Cervical Sympathetic; Occurrence and Symptoms; Irritation and Paralysis; Methods of Electrical Treatment—Vasomotor Neuroses—Cutaneous Angioneuroses—Symptoms of Spasm and Paralysis of the Vasomotor Neuroses; Methods of Electrical Treatment—Intermittent Dropsy of the Joints—Vasomotor Trophic Neuroses of the Integument—Anomalies of the Secretion of Perspiration—Progressive Facial Hemiatrophy; Probable Site; Methods of Electrical Treatment—Scleroderma; Method of Treatment.

In giving a short description of the electro-therapeutics of diseases of the cervical sympathetic, I shall refer alone to those diseases of this tract or its immediate origin in the cervical spinal cord, whose existence has been firmly established to a certain extent. I am by no means of the opinion that migraine, Basedow's disease, progressive facial hemiatrophy, or even progressive muscular atrophy, may be included with any degree of probability in this category.

The cervical sympathetic reacts to morbid influences like every other peripheral nerve, and its diseases are included, therefore, under the same therapeutic standpoints as the lesions of other nerves. Such affections are of rare occurrence, and isolated lesions of the sympathetic, indeed, constitute pathological curiosities. But they present such a peculiar and characteristic symptomatology, and they possess so great a significance on account of the numerous relations of the sympathetic to all possible parts of the central nervous system, the organs of special sense and certain vegetative organs, that their separate consideration appears justifiable, however skeptical we may be with regard to the mysterious relations of the cervical sympathetic to other neuroses.

Diseases of the sympathetic may be produced by inflammation, rheumatic influences, trauma, compression, etc., by diseases of the cervical cord and medulla oblongata, and occasionally also by impalpable lesions (hysteria, neurasthenia). These affections appear, in general, under two forms, either as irritation or paralysis of the sympathetic; but both conditions may coexist, irritation being predominant in one portion of the

fibres and paralysis in another, or they may follow one another. The resultant symptomatology is sufficiently characteristic, but usually requires very careful examination, since the oculo pupillary as well as the vasomotor symptoms are often not well marked.

The symptoms of irritation of the sympathetic consist of pallor and coolness of the corresponding side of the face and head, hardness and tension of the temporal arteries, dilatation of the pupils (with diminished reaction to light or power of accommodation), moderate protrusion of the eyeball and slight dilatation of the palpebral fissure, diminution of perspiration, etc.

The symptoms of paralysis of the sympathetic consist of increased temperature and redness of the side of the face, head, and neck, a feeling of heat and paræsthesia, dilatation and increased pulsation of the arteries, congestion of the conjunctiva, headache, vertigo; furthermore, contraction of the pupil with retained reaction to light and power of accommodation, narrowing of the palpebral fissure, slight retraction of the globe, increased secretion of tears and perspiration, etc.

Electrical examination will not aid the diagnosis, since irritation of the sympathetic can not be effected with certainty, but the application of the electrical current in such cases occasionally will influence the morbid disturbance forthwith and thus afford aid in the choice of the therapeutic procedures.

138. *Observation by Otto. Paralysis of the cervical sympathetic.*—Mrs. E—, never very sick, was suddenly affected in the spring of 1870 with vomiting, headache and vertigo; diminution of vision. Disappearance of symptoms in two weeks, but marked redness was then noticed in left half of face and neck; later, difficulty of speech, impairment of memory; occasional feeling of burning heat in head, with vertigo and increased redness of the parts mentioned; attacks increased on excitement. Absolute insomnia, depression and constant excitement; profuse perspiration frequently appears on reddened parts. Condition remained almost unchanged at end of one and one half years; cervical sympathetic not tender on pressure.

Galvanization of sympathetic with Ca; after application of three minutes, patient almost free from vertigo, and slept uninterruptedly the following night. After ten sittings, patient almost free from vertigo; the erythema, which had grown pale during the passage of the current in the first few sittings, disappeared almost entirely; sight and speech better, disposition more cheerful. Cured permanently after eighteen daily sittings.

The electrical treatment is similar, on the whole, to that of lesions of the peripheral nerves; if the lesion is situated in the cervical sympathetic itself, it should be treated according to general principles; if it may be assumed that the affection is located in the cervical cord, this should be treated in the well-known manner.

When such treatment is impossible, the method of application depends

upon the character of the main symptoms, especially of the vasomotor disturbances, as I shall explain in detail at a later period. I will merely mention at this time that the symptoms of irritation of the sympathetic should be treated exclusively by the galvanic current, preferably by the stabile application of the anode. A "medium" or an elongated electrode is applied to the sympathetic or its chief ganglia (Ca upon the spine or in an indifferent position) and quite a strong current passed stabile for a few minutes, until an effect upon the vessels or the pupil is noticed.

In distinct paralysis of the sympathetic a mild and short application of the Ca is indicated with a feeble current, frequent interruptions, and repeated cathodal closures, perhaps also some changes of polarity. Very short sittings (one to two minutes) should be had, since otherwise the opposite effect may be produced. Moderate faradization of the nerves may also be tried.

It will be useful, as a general thing, to combine this with similar treatment of the centres in the cervical cord, in the one case the stabile application of the An, in the other a moderate stabile, perhaps also labile application of the Ca.

In some cases peripheral treatment may also be added as an auxiliary, the integument of the face and its vessels being treated with the An or Ca stabile or labile, or with the faradic brush, the latter being employed to produce reflex relaxation and redness of the skin in spasm of the vessels.

Vasomotor disorders occur with extreme frequency. You are aware that peripheral nervous affections (neuralgias, anæsthesias, paralyzes), as well as spinal cerebral diseases, are often accompanied by such disturbances, but then, as a rule, they require no special treatment. But such disturbances occur occasionally in a more independent manner—affections in which irritative or paralytic conditions of the vasomotor nerves and corresponding changes in the calibre of the vessels and in the circulation constitute the primary and essential feature, which may in turn give rise to a number of effects upon sensation, motion, action of the heart, cerebral function etc. These are known as vasomotor neuroses. They play perhaps a much more important part in the pathology of many internal organs than we now imagine, but those which are more accurately known are merely the vasomotor neuroses in the tegumentary and, at the most, the deeper distribution of the cervical sympathetic, while we know very little concerning the vasomotor neuroses of the internal organs.

The cutaneous angioneuroses will engage our attention for a moment. They appear merely in two forms but of very variable localization, sometimes more diffuse, sometimes sharply localized in certain nerve-tracts. The limbs, especially the upper ones, are the most frequent site of these

neuroses, then the face and neck, *i.e.*, those parts which present normally the greatest variation in the vasomotor phenomena.

Spasm of the vasomotors (cutaneous angiospasm) is manifested by contraction of the vessels, pallor and coolness of the skin, which sometimes looks as white as chalk and cadaverous, especially in the fingers, or assumes a more livid, cyanotic coloration after prolonged continuance of the spasm; this is usually associated with spasm of the small muscles of the skin (*cutis anserina*) and the sequelæ consist of formication, pain, diminished sensibility, awkwardness in executing delicate movements, etc., advancing to changed action of the heart and even vasomotor angina pectoris, if the disorder is wide-spread. The condition is usually paroxysmal, and is increased by cold, etc. The very rare condition known as liver angioneuroticus ("essential cyanosis") may be regarded, perhaps as the analogue of the former; it is characterized by a flecked, dark bluish red congestion, with dull pain, objective coldness, sometimes associated with hæmaturia, and occurring in paroxysms probably due to temporary spasm of the small veins of the skin.

Paralysis of the vasomotors (cutaneous angioparalysis) appears in the form of intermittent or permanent flecked or diffuse redness ("essential redness") and increased temperature of the skin, with increased pulsation, paræsthesiæ, perhaps also with headache, vertigo, sleeplessness, irritable action of the heart, increased production of perspiration, etc. In individual cases this affection, especially in the hands and feet, has been found associated with severe pains and hyperæsthesia.

These cutaneous angioneuroses occur mainly in nervous, hysterical, neurasthenic individuals and may be produced by all possible morbid influences (cold, manipulations in water or acrid fluids, certain poisons, etc.).

The interpretation of these various disturbances is impossible in the present state of our knowledge and in the unsettled condition of the question concerning the existence and distribution of the vasodilator and vasoconstrictor, inhibitory and irritant vasomotor paths and centres in the spinal cord, and in view of the possibility that they may be stimulated in a direct as well as reflex manner.

The previously reported case of Otto (Observation 13) is an excellent illustration of vasomotor paralysis; the following history will serve as an example of vasomotor spasm:

139. *Observation by Nothnagel. Vasomotor neurosis of the upper limbs.*—A woman, aged forty-nine years. Six years ago, feeling of formication in both hands and shooting pains extending to the arms, improvement after the lapse of six months; occasional complaint since then. Violent exacerbation during past three months. Status: complains of a dead feeling, formication and severe pains in both hands and forearms of variable intensity; improved by warmth and work, rendered worse by cold and rest; very bad at night. Sensibility slightly dulled; all symptoms somewhat

more marked on left side; no tenderness on pressure. Farado-cutaneous brush for a long time with little effect. After a long intermission, galvanic treatment three times a week (An upon the plexus, Ca on the neck, stabile currents for three to five minutes). Left extremity entirely relieved in three weeks, right limb much improved; gradual recovery.

It would be premature, in the present state of our physiological knowledge, to decide with any degree of certainty upon the methods of electrical treatment of the vasomotor neuroses. We are forced to determine the most useful method empirically, by the therapeutical experiment.

A starting-point is furnished us by the scanty electro-physiological data, to which I have referred previously (Lecture VI), viz., that moderate faradic stimulation mainly contracts the vessels, severe faradic irritation, especially the brush, leads to secondary dilatation; the galvanic current first causes contraction, then dilatation, the latter occurring so much more rapidly the stronger the current; cathodal closures contract the vessels, anodal duration dilates them widely; finally, ascending or descending stabile galvanic currents in some nerves cause the vessels to dilate.

In vasomotor spasm, therefore, the stabile application of the An upon the vasomotor nerves and centres (and also upon the vessels themselves) is chiefly to be recommended. Nothnagel applied, with very good results, the An upon the brachial plexus, the Ca in the neck, stabile, for three to five minutes. Strong stabile currents in different directions may also be passed, for quite a long time, through the affected nerves; dilatation of the vessels may also be obtained by vigorous faradization of the nerve trunks and by the application of the faradic brush to the skin. In obstinate cases these various methods may be tried in succession.

In vasomotor paralysis the opposite methods of treatment are advisable: the stabile application of the Ca to the affected nerves and centres, with a feeble current and repeated interruptions; a few changes of polarity, with a not too strong current of short duration, may also be made. Also, a mild labile application of the Ca to the nerves and skin, with very feeble currents; likewise feeble faradization of the nerves and integument with moist electrodes, or a brief and not very strong application of the faradic brush. It is advisable in such cases, perhaps, to apply the wire brush to remote nerve trunks and parts of the skin, preferably upon symmetrical parts of the body. But it has not been determined as yet what the localization and strength of the stimulus should be in order to produce reflex contraction or dilatation in a definite vascular territory. According to Rumpf's experiments it seems that feeble and moderate faradization is most serviceable in producing contraction upon the non-irritated side of the body (after previous dilatation), while very strong currents produce marked permanent dilatation, after previous contraction, upon the non-irritated side.

But all these methods need to be tested practically in cases of disease in which entirely different phenomena are often presented from those which we are led to expect from physiological experiments. Not until such therapeutic experiments have been made in a series of cases will we be able to reach a more positive conclusion with regard to the results of electro-therapeutics in vasomotor neuroses. For the present, however, it may be said that the results are satisfactory, on the whole, and often follow very rapidly, especially in milder cases of such neuroses.

There are various reasons for including among the vasomotor neuroses the equally rare and peculiar, periodically recurring joint affection, known as hydrops articularum intermittens. This view of the affection naturally implies an attempt at electrical treatment. This was done unsuccessfully by Seeligmueller ; but Pierson states that he had favorable results in one case from galvanization of the neck. If such a case comes under your care, I should advise, during the attack itself, the method of treatment recommended on the preceding page for vasomotor paralysis, the applications being made to the knee itself, to the corresponding nerve-trunks, and the spinal cord, perhaps also to the other leg or to the sole of the foot on the same side (mainly feeble currents). During the intervals, treatment of the lumbar cord, the crural and sciatic nerves, with the galvanic current, appears to me to be indicated.

Various diseases have also been included recently among the vasomotor-trophic neuroses, or at least have been brought in relation with anomalies of the nervous system. Among these affections I will merely mention the various forms of erythema, urticaria, and especially herpes zoster. These processes are, indeed, of very little interest to the electrotherapist at the present time, but they offer a very fine field for electrotherapeutic experiments. The neurotic character of the affection is least doubtful in herpes zoster ; this may occur independently or be associated with neuralgia in the same locality. It appears to depend upon inflammatory processes (neuritis), either in the peripheral nerves or more frequently in the spinal ganglia or in the Gasserian ganglion. In appropriate cases, therefore, the treatment suitable to neuritis (*vide* Lecture XX.) should be resorted to. As a rule, this will be unnecessary, at least in herpes zoster, since the disease usually recovers spontaneously in a few days. At all events, the presence of zoster is always an indication that the neuralgia which may be present depends upon neuritis and that the

treatment should be directed specially to the region of the spinal ganglia or the Gasserian ganglion. The circumscribed anæsthesiæ of the skin which are sometimes left over after severe herpes zoster are treated in exactly the same manner as other anæsthesiæ.

Among the vasomotor neuroses were included formerly the anomalies in the secretion of sweat, which sometimes attain a certain independence, may present remarkable forms and localizations, and, in fact, are combined not infrequently with the vasomotor neuroses. At the present time, however, we know that the secretion of sweat is presided over by its own nerves and cerebro-spinal centres, and that these neuroses may thus present a certain independence. When, as occurs in certain vasomotor neuroses (angioparalysis), an increased secretion of perspiration is regularly found, this may be explained by the increased supply of blood and the rise of temperature, which stimulate the sweat-glands, but is probably not due to paralysis of the inhibitory nerves of the secretion of perspiration. However, these neuroses may be entirely independent of vasomotor disturbances.

They appear in the form of hyperidrosis (increased secretion of sweat) and anidrosis (diminished secretion of sweat), either more or less diffused or locally circumscribed, especially frequent upon one half of the face and with or without vasomotor disturbances or symptoms of an affection of the sympathetic.

Little is known with regard to their electrical treatment. If the anomalies of the secretion of sweat are merely the result of a vasomotor or sympathetic neurosis, and of the changes in the circulation induced thereby, these disturbances must be treated in an appropriate manner. If the affection is independent, it must be treated like the vaso-motor neurosis, a stimulating method being employed in anidrosis, the reverse in hyperidrosis.

I will call attention at this place to an affection which, perhaps more than all others, merits the appellation of a tropho-neurosis, viz., progressive facial hemiatrophy.

This chronic progressive atrophy of one half of the face, extending to the soft parts, the integument, and bones, and finally leading to very great deformity of the face, is evidently neurotic in its origin, although nothing positive has been determined with regard to its real nature and the localization of the process.

I am inclined to the opinion that this disease is an affection of the trigeminus nerve; the view that it is situated in the cervical sympathetic appears to me much less plausible. It is entirely uncertain whether the

lesion is situated in the Gasserian ganglion, or in more central paths or in a trophic centre which is connected with the origin of the trigeminus.

Experience teaches that this affection is incurable after it has been fairly established. It is only in the very beginning of the disease, therefore, that there is any chance of producing good results from treatment.

As the most suitable method of treatment I should recommend the following: galvanization of the trigeminus, especially the region of the Gasserian ganglion (transversely through the middle temporal region); then galvanization of the medulla oblongata (transversely through the mastoid processes) and the cervical cord, in order to influence the nuclei of origin of the trigeminus; likewise galvanization of the cervical sympathetic, in order to stimulate the trophic processes by increasing the flow of blood; finally, direct treatment of the face with stabile and labile cathodal applications in order to produce the same effect.

Finally, I may be permitted to say a few words with regard to so-called scleroderma, a very peculiar affection of the skin and the subjacent soft parts, which is more and more regarded as trophic and vasomotor in its origin. The vasomotor disorders which not infrequently precede the disease, the processes which run their course with symptoms of an atrophic inflammation of the skin, the atrophy, tension, and glossy appearance of the skin, the shrinking of the subcutaneous cellular tissue, the atrophy of the muscles, abnormal pigmentation, anomalies in the growth of the hair and nails, the symmetrical development and progressive character of the disease, all favor its nervous origin, though this is by no means positively proven. Perhaps the affection is located in the spinal cord and its trophic centres, perhaps also in the sympathetic and its ganglia.

Many trials of electrical treatment have been made in this disease, and I have treated an entire series of cases with very little success. Recently, however, I have secured an undoubted improvement by galvanic applications (combined with arsenic and inunctions of fat) in a case which had lasted six to seven years.

The following was the method employed: galvanization of the cervical and lumbar enlargements of the cord with stabile currents and change of polarity; then galvanization of the cervical sympathetic in the ordinary manner; finally, peripheral labile (Ca) galvanization of the skin in all the parts affected (back, neck, chest, upper limbs, especially the hands) with sufficiently strong currents to produce redness of the skin. The result was not merely subjective, but also very evident objectively, although, as a matter of course, there was no question of recovery.

Fieber has successfully treated, by a similar method, a case in which the disease was confined to the left upper limb.

IX. GENERAL NEUROSES.—CENTRAL AND OTHER FUNCTIONAL NEUROSES.

LECTURE XXX.

Theory of the Functional Neuroses—Electro-therapeutic Objects: Removal of the Local Nutritive Disturbances; Influence upon the Entire Nervous System and the Entire Organism; Removal of Definite Causes of Disease; Treatment of Individual Symptoms—1. Neurasthenia: Various Forms; Nature of the Disease; Methods of Treatment; Results—2. Hypochondriasis—3. Hysteria; its Nature, Object, and Methods of Electrical Treatment—4. Epilepsy—5. Co-ordinate Professional Hyperkineses; Writer's Spasm; Various Forms; Methods of Treatment—6. Chorea Magna.

Of the diseases of the nervous system in the strictest sense it now remains to discuss a large group of frequent, severe, and important affections. These morbid processes vary greatly in character, but a feature common to all is that they must be regarded as so-called "functional neuroses," *i.e.*, diseases in which a gross anatomical lesion is not demonstrable by our present means of investigation. Not even the exact localization of these affections in the nervous system—whether in the peripheral nerves, spinal cord, brain or sympathetic system—is always known, or several localizations must be assumed at the same time; indeed, in certain forms of these neuroses, a general, diffuse affection of the entire nervous system is assumed, and they are called "general neuroses."

We are apt to believe that purely functional, molecular and finer nutritive disturbances will be relieved more readily than grosser anatomical lesions by the action of electricity. Nevertheless, the electrical treatment of these functional neuroses is only in the first stages of its development.

The causes of this circumstance are manifold; in the first place, our ignorance of the situation and character of the affection, which always antagonizes therapeutic trials; then the dread of a bad effect upon forms of disease which are in themselves dangerous, and are associated with irritative symptoms, and in which we fear the application of a new "irritant;" furthermore, the great sensitiveness of the patient to all therapeutic measures, and so also to the electrical current, which, when applied incautiously, produces unfavorable symptoms; and finally the many failures

of electrical treatment in these neuroses, and which, though they may be explained in part by an improper choice of the method of application, none the less deter from further attempts.

However, it appears to me to be urgently indicated not to give up these attempts entirely, but to renew them again, modified and improved by our daily progress in the knowledge of these obscure and remarkable diseases. And I shall, therefore, not omit their consideration, although their electrical treatment hitherto has not possessed much practical significance.

The first object, especially in those functional neuroses which can be localized with some degree of certainty, is the removal of the local nutritive (functional) disturbance. The catalytic and alterative actions of electrical currents must be relied upon for this purpose, and they may be secured by various methods (stable galvanization or faradization, central galvanization, application of feeble, continuous currents); or this purpose may be sought for in an indirect manner by influencing the circulation of the diseased parts, and by indirect catalysis (galvanization of the sympathetic and the cervical cord, reflex action from the skin, etc.). As a matter of course, such applications may be variously modified in individual cases.

In the second place, a stimulant, modifying, alterative influence upon the entire nervous system, or even the entire organism, may be employed as a curative measure. The former, in the so-called general neuroses, which involve the greatest part of the nervous system at the same time; the latter partly in the same direction, partly in order to exert a favorable influence upon the nervous system by improving the general nutrition and stimulating the entire organism. For these objects we should resort especially to the methods of general faradization, general and central galvanization and the electrical bath.

It may also be our object to effect the removal of definite causes of disease in so far as they are accessible to the electrical current, and in so much as they produce the disease or give rise to individual attacks. In this category belong, for example, the relief of peripheral neuralgias, so far as they affect the development of epilepsy, chorea, tetany, etc., the treatment of an aura which regularly precedes an epileptic attack, the relief of ovarian hyperæsthesia in severe forms of hysteria, the relief of spermatorrhœa, etc., as causes of spinal neurasthenia, the treatment of painful points in writer's spasm, chorea, hysteria, etc.—all these objects must be effected according to the previously mentioned rules and methods.

Finally, a very wide field of activity remains in combating individual prominent symptoms of the functional neuroses, such as convulsions, paralyzes, neuralgias, hyperæsthesiæ, anæsthesiæ, migraine, vasomotor and trophic disorders, impotence and spermatorrhœa, asthenopia and photophobia, conditions of fear and insomnia. In certain forms of disease which

present but one or a few symptoms, and whose pathogenesis and localization are perhaps obscure, this very object may occupy the foreground to such an extent as to constitute the main feature in treatment. But in almost all these cases it is well to pay special attention to the methods of central treatment.

Let us now see what can be done by such means in the individual forms of the functional neuroses.

I begin with the most frequent, and perhaps the most important, of these affections, viz. :

1. *Neurasthenia or nervous exhaustion.*—This is the fashionable neurosis of the present time, and appears in a thousand remarkable forms. It may be best described as a marked degree of irritable weakness of the nervous system, accompanied by the most varied functional disturbances, although we are not justified in assuming an anatomical foundation.

This is not the place to enter into the symptomatology of this affection. In making the diagnosis, however, you should always remember that, despite the innumerable complaints of the patient, the most careful examination always affords an absolutely negative result (with the exception, perhaps, of some spinal tenderness on pressure, a slight increase of the reflexes, coldness of the hands and feet). Every objective change, however slight, of sensation, motion, the reflexes, pupils, etc., must cast a doubt upon the accuracy of the diagnosis. Electrical examination offers no assistance, since it reveals, as a rule, absolutely normal conditions.

With regard to treatment, it is advisable to differentiate various forms of the disease: one in which the cerebral functions are mainly affected (cerebral neurasthenia), and which is especially characterized by a sense of pressure in the head, inability to work, sleeplessness, psychical depression, pathological sensations of terror ("fear of places," dread of lightning, shooting, human beings, diseases, etc.), palpitation of the heart, etc.; another which affects mainly the spinal functions (spinal neurasthenia and spinal irritation), and in which weakness and a feeling of exhaustion, pain in the back, tremor, paræsthesiæ and pains in the limbs, disturbed sexual function, vasomotor disorders and the like occupy the foreground; and, finally, a not infrequent combination of both, in which the disturbances are diffused more or less over the entire cerebro-spinal system (general neurasthenia) and may occur in the most manifold combinations.

All considerations concerning the character of this widespread neurosis lead to the exclusion, as causes of the disease, of circulatory disturbances (hyperæmia or anæmia) of the nervous system as well as of grosser anatomical changes. In the majority of cases the circulatory changes are not the causes but the results of the disease, and are merely the expression of the neurasthenic affection of the vaso-motor apparatus itself. However, this may be the primary feature occasionally (vaso-motor neur-

asthenia), and then cause further disturbances by leading to abnormal distribution of blood in the central nervous system. In the large majority of cases, however, we must assume a finer nutritive disturbance of the implicated nervous apparatus, the real nature of which is entirely unknown, and for whose functional expression the conception "irritable weakness" is the most appropriate.

In addition to other remedies, electricity often produces admirable results in the treatment of this neurosis. Its office consists in the removal of the nutritive disorder of the nervous system, in the strengthening of the entire organism, and in combating individual and especially annoying symptoms. The galvanic as well as the faradic current may be employed for this purpose. In the cerebral form, the galvanic current is used in galvanization of the head, sympathetic and cervical cord in the manner which I described in detail under the head of electro-therapeutics of the brain; in the spinal form, galvanization of the spine and the sympathetic, perhaps also of the legs, is performed in the manner previously described (I prefer the descending current). In general neurasthenia, both forms of application or central galvanization may be resorted to.

The faradic current may be employed with the same methods of application, but I would recommend specially general faradization as a very valuable method in such cases. If the affection is characterized by very marked vasomotor disturbances and symptoms of congestion of the brain and spinal cord, you should not fail to employ the treatment with the faradic brush recommended by Rumpf (application of the brush to large portions of the integument of the trunk and extremities).

A long series of symptomatic indications may also be presented. Headache, migraine, pains in the back are treated according to the directions laid down in the discussion of neuralgia (Lectures XXV. and XXVI.). Galvanization or faradization from the neck to the epigastrium and the præcordial region, and galvanization of the sympathetic and pneumogastric are not infrequently useful in feelings of terror attended with palpitation of the heart, etc. In insomnia, the methods previously mentioned (Lecture XVI.) may be employed. Weakness and pain in the legs are not infrequently ameliorated by direct faradic or galvanic applications. Sexual weakness, premature ejaculation, impotence, etc., may be treated by the methods which will be described at a later period (Lecture XXXVI.); faradization of the rectum is often useful in constipation (*vide* Lecture XXXV.).

Great caution should be exercised in the employment of any of these methods. We have to deal with extremely irritable and sensitive individuals, and very feeble currents and short applications, therefore, should always be resorted to at the onset; every patient should be tested, at the beginning of treatment, with regard to his "electrical sensitiveness."

The results of electrical treatment in neurasthenia are by no means

always prompt and brilliant. Very satisfactory and rapid results will be achieved in some cases, especially in the milder forms with a slight neuropathic taint. In many cases, prolonged and patient treatment will pave the way merely for gradual improvement, and not infrequently time and labor will be wasted upon patients whose disease resists the most judicious and varied treatment.

2. *Hypochondriasis* presents intimate relations to neurasthenia and also leads gradually into the domain of the psychoses. It may be described as a form of mournful depression, in which the attention of the patient is concentrated chiefly upon morbid conditions of his own person and their possible evil results (pathophobia). It is developed usually upon the foundation of a neuropathic anomaly of constitution, is associated very often with disturbances of the digestive organs and the sexual apparatus and in addition presents numerous nervous disorders, such as abnormal sensations, insomnia, sensations of terror, apathy, constipation, etc. In these cases, also, the objective appearances do not correspond in any respect to the intensity of the subjective complaints.

In this neurosis electricity is resorted to with relative infrequency and perhaps more rarely than it deserves. The same methods may be employed as in neurasthenia, especially general faradization. A very favorable effect is produced not infrequently by the treatment of prominent symptoms of the disease, such as constipation, impotence, insomnia, etc., by the methods described above.

In addition, all these patients should undergo careful psychological treatment and the electro-therapeutic procedures should also be utilized for this purpose. I would also remind you to be careful in the selection of the strength of the current, since many of these patients are very sensitive.

3. *Hysteria*, this remarkable functional neurosis, with its innumerable symptoms and its variable course, is a frequent object of electro-therapeutics, despite numerous and often surprising failures. On the whole, hysteria resists electrical treatment as obstinately as it does all other measures. This must be attributed in part to psychological causes, in part to the often enormous irritability of the patient.

The nature of the affection is still very obscure and we are forced to assume the existence of extremely changeable, nutritive disturbances. In many respects we are even in doubt with regard to the localization of these disturbances, though it is probable that they occur mainly in the central nervous system, but a peripheral localization is by no means excluded for a series of symptoms (neuralgia, hyperæsthesia, paralysis, etc.).

Hysteria is also an affection which is curable with extraordinary difficulty, and this is due in part to the congenital neuropathic taint, in part to the constant presence of causal morbid influences, whose removal is impossible.

The main object of treatment is the removal of the disease itself, i.e. of the morbid disturbance of nutrition of the nervous system. For this purpose, we may resort to general faradization, electrical baths, general galvanization; likewise to galvanization of the spine with ascending stable currents, the chief attention being paid to the cervical cord and sympathetic. On account of the extreme irritability of hysterical individuals, trial should be made of the application of feeble continuous currents along the spine (with a pair of galvanic elements). The disease, as a whole, is favorably influenced at times by treatment of the pressure points and painful points along the spine and also by the treatment of ovarian hyperæsthesia, as practised by Holst (An upon the spine, Ca upon the painful ovary, stable current) or according to the method recommended by Neftel in visceral neuralgias (*vide* page 258).

In this treatment of hysteria special precautions must be employed. In scarcely any other neurosis do psychical factors play so important a part as in this. Confidence in the physician and the remedy is the best guarantee of success, and you should endeavor, by all means, to secure this confidence, and not destroy it by the careless application of a strong current. Always begin with very feeble currents and applications of short duration. I have often thought it desirable to test the effect of the psychical impression upon such patients and have begun the treatment, therefore, by applying the electrodes in the proper manner without closing the circuit. The statements made to us concerning the effects of such a sitting may be remarkable, but they give a clear idea of how much must be attributed to imagination and mental excitement, and how much to the action of the current. The confession of this deception may produce a decided psychical impression and thus hasten recovery in intelligent patients; in others, the opposite effect will be produced by such candor, since the offended vanity of the patient will not forgive the physician.

The treatment must always be pursued slowly, intermitted at times, and excessive irritation must be avoided.

Symptomatic treatment possesses a wide field of action in the disease. It must be carried out according to the methods previously described, though modified in certain respects by the general condition of the patient.

In hysterical paralysis the methods ordinarily adopted in paralysis are admissible. In electro-diagnostic respects I will mention merely that the electrical excitability of the motor nerves and the muscles is in no wise changed, as a rule, and that the statement of Duchenne that the electromuscular sensibility is usually extinguished, does not hold true by any means of all cases of hysterical paralysis. This feature is also observed occasionally in paralysis of a different origin. The therapeutic results in the hysterical form are sometimes (for example, in hysterical paralysis of

the vocal cords¹) extraordinarily prompt and indeed magical, at other times they are the very reverse, so that long-continued treatment is necessary before recovery occurs; this is especially true of paralysis occurring in the form of paraplegia.

In anæsthesia, the methods recommended in Lecture XXIX. should be adopted; the plan recommended by Vulpian, viz., the application of the local faradic brush to a circumscribed part of the skin of the forearm, sometimes has a brilliant effect in the not infrequent hemianæsthesia of hysterical individuals.

In hysterical convulsions, electrical treatment is often useless, despite every possible method of application. In contractures, good results may be obtained sometimes from the galvanic current (descending stabile), sometimes from the faradic current; likewise from the continued application of a feeble galvanic current (Lenoir). It is said (Richet, Roux) that hystero-epileptic attacks are sometimes shortened and ameliorated by the passage of a stabile galvanic current (10 to 15 elements) from the forehead to any part of the body. Sudden change of polarity of a very strong galvanic current (40 to 50 elements Trouvé) applied in this manner, will terminate such an attack at once, but does not prevent its recurrence.²

The globus hystericus may be treated by galvanization or faradization of the neck and pharynx, perhaps also by the passage of a current from the back of the neck to the epigastrium; this is also useful in nervous vomiting, in addition to a vigorous application of the farado-cutaneous brush to the pit of the stomach. Faradization of the intestines may be resorted to in obstinate constipation and in hysterical tympanites.

4. *Epilepsy*.—Hitherto this severe and mysterious neurosis has been made the subject of electrical treatment with comparative infrequency.

The real nature of epilepsy is still obscure, despite all the clinical and experimental investigations with regard to it and despite more or less ingenious attempts at its explanation. Even the localization of the disease, which had been referred to the region of the pons and medulla oblongata with tolerable certainty, is now rendered doubtful. The recent observations upon cortical epilepsy seem to point to the motor parts of the cerebral cortex as the place of origin of epileptic convulsions.

At all events, it is certain that the true site of epilepsy must be sought in the brain and that it is due to a peculiar disturbance within this organ, which is manifested from time to time by a sort of explosive discharge, i.e., by the epileptic attack. This disturbance, which is known as the "epi-

¹ In hysterical aphonia Emminghaus has sometimes obtained successful results from galvanization transversely through the mastoid processes, but he is unable to decide whether this is due to a physical or a psychical effect.

² Static electricity has recently been tried in Paris (Charcot, Vigouroux), and not without good results, in all possible hysterical symptoms, as well as against the disease as a whole.

leptic change," is dependent very probably not upon gross anatomical changes but upon finer nutritive and molecular processes.

Electro-therapeutic measures in epilepsy have been resorted to by various writers, but they have not obtained many followers in this direction.

As a matter of course the electrical current is powerless against the attacks themselves; our endeavors must be directed entirely toward the removal of the "epileptic change" in the brain. This may be done directly or indirectly (by removal of its causes or by reflex action).

In the former method the catalytic and vasomotor actions of the current are alone available, viz., direct applications to the head, the cervical sympathetic, and the cervical cord. Althaus recommends transverse galvanization through the mastoid processes, and galvanization of the sympathetic. In my recent experiments I have employed the following method: a stable, very feeble current (4 to 6 elements) obliquely through the head, from the temporal region and upper part of the forehead on one side (Anode, large head electrode) to the opposite side of the back of the neck (Ca, large electrode), from one-half to one minute on each side; then longitudinally from the forehead (An) to the back of the neck (one-half to one minute). In some cases, especially if the vasomotor symptoms are marked during the attack and also in the intervals, I add galvanization of the cervical sympathetic.

Careful trial of faradic currents to the head also appears to me to be justifiable, and they should be applied as in the treatment of migraine.

General faradization may be employed for its indirect effects upon the brain. Althaus strongly recommends galvanic treatment of those peripheral nerve tracts in which the aura is situated. If points of pressure or galvanic painful points are demonstrable, treatment should be directed toward them; likewise if a neuralgia or a peripheral nerve injury, a cicatrix or the like is suspected as the starting-point of the epilepsy, even if it is not the site of an aura.

Successful results are very scanty, but Althaus has reported some very striking cases. I have had a very favorable impression in the few cases which I have treated electrically of late years, so that I am encouraged to renewed trials. But not until we are in possession of a large number of individual experiences will we be able to make more accurate indications concerning the selection of cases for electrical treatment and the methods to be adopted.

5. Under the term *professional hyperkineses* are usually included all those functional neuroses which present the common feature that, in certain complicated and delicate manipulations, disturbances of movement occur which interfere with the manipulation in question or render it entirely impossible. The so-called writer's spasm is the type of these neuroses, but analogous disorders may occur in other occupations, such as

drawing, sewing, playing upon the piano or violin, milking, telegraphy, making cigars, etc.

There is no doubt that these neuroses do not constitute a constant form of disturbance but that they include various affections. In very rare cases distinctly localized spasmodic and paralytic conditions may be observed; these constitute the more favorable forms in which the treatment has a definite point of attack.

But the disease may be manifested in a variable form in the purely functional, typical varieties—as a definite spasm occurring during writing (spastic form), or as tremor, or, finally, as increasing exhaustion and weakness of the hand and arm during writing (paralytic form). The characteristic feature of all these forms lies in the fact that examination reveals no further disorders of motion and sensation. Electrical examination, as a rule, shows no noteworthy changes.

We are still very much in the dark with regard to the real nature of these forms of disease; they present undoubted intimate relations to neurasthenia, and are probably due to a localized irritable weakness of certain parts of the nervous system caused by over-exertion. This is situated mainly in the central nervous system, though we are ignorant as to its localization in the spinal cord, the basal ganglia or cortex of the brain; nor is the implication of the peripheral apparatus, the nerves and muscles, excluded with certainty.

This uncertainty naturally reacts upon electro-therapeutic methods, since it may be assumed that various applications will be effective. If any peripheral disturbance is discovered, such as paresis, atrophy of individual muscles, neuritis, anæsthesia, etc., this must be treated first; when there is marked neurasthenia, endeavor to remove this if possible.

In other respects, you must restrict yourself to direct treatment, especially to applications to the entire motor apparatus from the cerebral cortex to the muscles, if not at once, at least successively and methodically. At first, galvanic applications to the head (transversely, longitudinally, obliquely). Then, treatment of the cervical sympathetic and especially of the cervical cord by various methods according to the character of the case (either ascending stabile, so that the Ca acts chiefly on the cervical cord, or stabile application of the An, as recommended in other forms of spasm). Finally, peripheral galvanization of the nerves and muscles (either more labile in the tremor-like and paralytic forms, or mainly with stabile currents, as in the spastic form). Relatively weak currents should always be employed, in order to avoid exhaustion of the motor apparatus.

Moritz Meyer has obtained very excellent results from the treatment of points of pressure upon the spinal column, the brachial plexus, etc., but unfortunately such points are demonstrable in very few instances. Wearing simple galvanic elements upon the arm and neck has seemed to me to possess at least palliative effects in individual cases.

Faradic treatment may be appropriate in certain cases, especially in peripheral local affections of the nerves and muscles. Local faradization with moderately strong currents is usually indicated.

On the whole, the results are very meagre. Improvement in writing, etc., may be noticed for a variable period after galvanization, but it does not persist and in a small number of cases alone do progressive improvement and finally recovery occur. This never takes place except after long-continued treatment and the most absolute abstinence possible from the injurious occupation.

6. *Chorea magna* is a very peculiar neurosis, which possesses, it is true, a certain relationship with hysteria and the psychoses, but may undoubtedly lay claim to independence. It is, on the whole, a very uncommon disease, which is still more rarely the subject of electrical treatment. It is manifested by attacks of disordered consciousness, associated with ecstasy, violent co-ordinated movements and spasms (shouting, dancing, singing, jumping, etc.), which may present very bizarre forms and surprising persistence.

We are entirely in the dark with regard to the character of this disturbance, but it is undoubtedly a functional disorder of the brain.

The purpose of electro-therapeutics in this disease can only be to produce a general tonic action upon the nervous system (by general faradization or galvanization, electrical baths, etc.) and thus prevent a return of the attacks. It may also be justifiable to attempt the production of a sedative action upon the central nervous system by careful galvanic applications to the head or by central galvanization.

LECTURE XXXI.

7. Chorea Minor: Its Situation and Character; Electrical Treatment—8. Tetanus: Methods of Treatment—9. Tetany: Its Characteristics; Electrical Excitability; Character and Location of the Disease; Electrical Treatment—10. Catalepsy—11. Tremor—12. Paralysis Agitans—13. Athetosis—14. Basedow's Disease: Symptoms and Location of the Disease; Methods of Electrical Treatment—15. Vertigo—16. Diabetes Mellitus and Insipidus.

7. *Chorea minor*.—This extremely frequent neurosis has often been the subject of electro-therapeutic trials and with undoubted benefit.

In many respects this is also an obscure affection. It is probably localized in the brain, though this is by no means entirely certain, and an implication of the spinal cord is not excluded. In ordinary cases it is probably merely a functional nutritive disturbance, but gross anatomical changes are found occasionally. It is even doubtful whether the peculiar characteristics of the abnormal muscular contractions are dependent on a definite kind of irritation or upon a definite situation of the affection which has given rise to the irritation.

The symptomatology of chorea is so well marked that it can rarely be mistaken. Electrical examination offers no characteristic results. It has been stated repeatedly that in chorea the faradic and galvanic excitability of the motor nerves is increased (Benedikt, M. Rosenthal, Gowers), and that this can be demonstrated very readily in fresh cases of hemichorea. Despite very careful examination I have been unable to satisfy myself of the truth of these statements. The painful points upon the spine and various peripheral nerves, discovered by Rosenbach by means of the galvanic current in one case, are present in very few instances.

Various methods have been employed in the electrical treatment of chorea minor. I make applications to the head so that the motor zones of the brain are situated directly between the electrodes, i.e., obliquely from the region of the central convolutions (*vide* Fig. 29, anode, large head electrode) to the opposite side of the neck (Ca, large electrode), for one-half to one minute on each side with a feeble current (4 to 8 Stoehrer's elements); or, in the manner recommended by O. Berger, with a bifurcated An upon both parietal regions, the Ca being placed in the hand or upon the back for five to ten minutes. In addition, galvanization of the sympathetic and the cervical cord may be performed in order to produce indirect catalysis.

Others have specially recommended applications to the spinal cord with feeble ascending currents, applied partly stabile, partly labile. Moritz Meyer, on the other hand, treated his cases with twenty-four to thirty interruptions of a strong current and Leube has also employed successfully a very strong current.

If points of pressure can be demonstrated, their treatment in the ordinary manner (An stabile) is usually attended with great benefit (M. Meyer, Rosenbach).

The faradic current was much employed in former times, but not very successfully; general faradization may be recommended, particularly in cases of relapsing chorea in nervous children.

The results of these methods of treatment are determined with difficulty in a disease of such variable intensity and duration as chorea. In my own experience brilliant results have not been obtained. No good effects have ever been secured in old cases of chorea in adults; the recent chorea of children, on the other hand, has been benefited very decidedly by electrical treatment and materially shortened in many cases.

8. *Tetanus* has rarely been the object of electrical treatment. It seems indeed hazardous to employ electricity, an irritant par excellence, in such a terrible spasmodic affection, in which every cutaneous irritation is usually followed by a fresh outbreak of convulsions. However, our knowledge of the sedative action of the galvanic current and of its reflex inhibitory influence upon the spinal cord (Ranke) might lead us to venture its application in this grave disease; and indeed some strikingly favorable results have been reported. Great caution must be exercised, however, in this respect, because so many cases of tetanus recover spontaneously.

The location and nature of tetanus have not, up to the present time, been entirely cleared up; the constantly recurring attempts to attribute tetanus to gross anatomical, inflammatory processes in the spinal cord, have not gained general acceptance hitherto. Nevertheless, it is located most probably in the spinal cord (including certain parts of the medulla oblongata), although no gross changes can be discovered.

Mendel observed recovery in two undoubted cases of tetanus which had been systematically treated by galvanism; he applied the An to the muscles or integument of the extremities, the Ca to the spine above the cervical and lumbar enlargements (the direction of the current sometimes reversed), feeble stabile currents being passed for a few minutes. The tetanic stiffness disappeared quite rapidly, the improvement continued after the sitting and gradually progressed to recovery. Whether the recovery in these cases was due to the action of the current upon the spinal cord, the muscles, or the peripheral sensory nerves can not be decided. Legros and Onimus report a case of tetanus which recovered under the use of very large doses of chloral and the application of the galvanic current, from which it appears that the employment of descending stabile

galvanic currents upon the spine has a favorable effect upon the spasm itself, relaxes the muscles and produces a feeling of relief; one to three sittings were held daily, the duration being one to two hours; the current should not be too strong and the electrodes very large.

From these few data definite conclusions can not be drawn concerning the therapeutic value of electricity in tetanus. In this disease I should be inclined to employ the direct action of the galvanic current upon the spinal cord, at first with the anode, perhaps later with the descending current; feeble stable currents, applied for a long time. Judging from Mendel's experience, the An should also be applied to the peripheral parts, especially to the sensory and mixed nerve trunks. At all events further experiments should be made in this direction.

9. *Tetany*.—The peculiar and not infrequent form of spasm known as tetany is a much more favorable object of electro-therapeutic experiments.

It is a spasmodic disease, manifesting itself by periodical and paroxysmal painful tonic spasms of certain groups of muscles; it affects chiefly the upper limbs, more rarely the lower extremities, sometimes other muscular groups of the trunk and head.

Careful observations have shown that a marked increase can be demonstrated in the excitability of the affected motor nervous apparatus. This is manifested by the occurrence of the characteristic spasms upon compression of the large nerves or arteries of the limbs (Trousseau's symptom); no less by the marked increase of the mechanical excitability of the nerves and muscles, and finally by the increased electrical excitability of the motor apparatus. This is found in almost all the nerves of the body, most markedly in those directly affected by the spasm. Upon the faradic examination, the nerves react to an extraordinarily feeble current; upon galvanic examination, Ca Cl C appears extremely early, likewise An O C: Ca Cl Te and An Cl Te occur very soon and, what is especially important and characteristic, An O Te is often produced with great facility. This increased excitability occurs not alone during the attacks but also in the interparoxysmal period.

Anatomo-pathological examination has furnished no satisfactory data with regard to the character and situation of the disease. A critical consideration of the symptomatology renders it probable that the condition is due to markedly increased excitability of a large part of the motor apparatus, the starting-point being probably in the anterior gray substance of the cord (with or without implication of the gray motor nuclei in the medulla oblongata).

The most rational method of treatment would seem to be the stable application of the An (the strength of the current being gradually increased and diminished) to those parts which are the site of the disease, viz., the cervical cord especially, the entire spinal cord, the individual nerve-trunks (Ca upon the sternum). All these parts should be treated

throughout their entire extent, the peripheral nerves being treated by applying the An first in the neighborhood of the muscles and then slowly passing upward to the plexus.

It must not be forgotten that other methods of application may also prove useful ; for example, Ca stabile with rapid Ca O, etc. These should be tried if the first method proves useless.

Nor is there any objection to a trial of the faradic current : faradization of the spine with large electrodes and moderately strong currents, likewise of the nerve-trunks.

It goes without saying that anodal applications should be made during the attacks, and I believe that I have observed repeatedly an immediate improvement and abbreviation of the attacks. Eisenlohr has also noticed repeatedly this immediate sedative action of the anode. As a matter of course, it must be continued during the intervals and for some time after the cessation of the attacks, until Trousseau's phenomenon or the marked increase of electrical excitability has disappeared.

Very many observations have not been made with regard to the results of electrical treatment in tetany ; almost all of those reported hitherto have been favorable.

10. *Catalepsy*.—In this remarkable form of disease, no opportunity of achieving great triumphs is offered to electro-therapeutics. On account of the great rarity of the affection and the manifold combinations under which it appears, the possibility of extended and careful therapeutic investigations is excluded almost entirely.

Electricity has been employed sometimes in catalepsy as a vigorous irritant with the purpose of thus rousing the patients from their trance. Indeed, this may prove successful, and, as a matter of course, the free use of the faradic brush is advisable. Vigorous faradization of the nerve trunks and muscles may also be employed.

As a curative remedy proper in catalepsy, electricity must be applied mainly to the central organs of the nervous system. In such cases, I have first employed central galvanization, then galvanization of the head and cervical sympathetic, perhaps vigorous galvanization and faradization along the spine, but usually without any noticeable effect.

11. *Tremor*.—This symptom may appear in various forms and from manifold causes. I now refer to those varieties alone which occur with a certain degree of independence, such as senile tremor, the various kinds of toxic tremor (alcoholic, mercurial, lead tremor), the neurasthenic tremor which is so frequent in nervous persons, tremor after acute diseases, idiopathic tremor of individual extremities, etc.

The majority of these forms of tremor produce the impression of irritable weakness, of an insufficient, oscillatory execution of individual movements and not of a true spasm.

Much benefit cannot be obtained from electrical treatment. The

choice of the method of application depends upon the general symptoms and the demonstrable etiological factors. As a rule, a moderately stimulating, invigorating method of treatment should be chosen.

In local tremor moderate galvanization or faradization of the affected parts and the corresponding region of the central nervous system should be performed and repeated regularly until recovery ensues. As it occurs chiefly in the upper limbs, treatment of the cervical cord (perhaps also of the brain) and direct electrization of the nerve-trunks and muscles of the upper limb with moderately strong currents are indicated. Excellent results are sometimes obtained in this manner (*vide* Observation 125).

In general tremor, especially in those varieties dependent on toxic influences, more reliance may be placed upon general methods of treatment, either central galvanization or general faradization. The electrical bath is highly extolled by French writers in toxic tremor, especially in the alcoholic and mercurial forms. Paul gives such patients a faradic bath, half an hour in duration, every two days.

The results are often very unsatisfactory, and I have treated, without avail, many cases of tremor after typhoid fever, etc., with all possible methods.

12. *Paralysis agitans*.—Undoubtedly the most severe and obstinate form of tremor is paralysis agitans, an independent neurosis of extremely characteristic and typical symptomatology. It is a disease of advanced life, the situation and character of which are quite obscure, though it has been rendered more probable recently that it is a disease of the brain.

This affection, into the clinical history of which it is unnecessary to enter, appears to be incurable; the reported cases of recovery are probably due to erroneous diagnosis. We cannot expect more than a passing relief, or, at the most, a temporary stand-still of the disease.

The method of treatment consists in galvanic applications to the head (obliquely and longitudinally, with large head electrodes), likewise to the sympathetic and cervical cord; in addition, descending stable and moderately labile currents through the peripheral nerves and the muscles. Central galvanization or general faradization may be tried, perhaps, in individual cases.

13. *Athetosis*.—This spasmodic neurosis sometimes occurs idiopathically, but more frequently after cerebral hemiplegia, and it is then related to post-hemiplegic chorea and the analogous tremor. It consists of peculiar restless, twitching movements, and a characteristic position of the hand and fingers, less often of the arm, and sometimes of the foot and leg.

The location and character of this disturbance are not known with certainty. It is generally assumed to be caused by an affection of the brain, though its spinal origin does not appear to me to be positively excluded. At all events, it is uncertain whether this peculiar affection is due to a definite location or merely to a definite character of the irritation.

The electrical treatment consists usually of galvanization of the head, the cervical cord, and the sympathetic, according to the well-known methods; also the An stabile to the back of the neck, the Ca upon the principal nerve trunks of the extremities. Gnauck obtained recovery in one case by the application of descending stabile currents to the cervical cord and the muscles. I have treated a number of cases without success; in one girl of twenty, suffering from bilateral athetosis following cerebritis, prolonged treatment produced at least distinct improvement and increased power of using the hands.

14. *Basedow's disease*.—This rather frequent neurosis is characterized by exophthalmos, a pulsating enlargement of the thyroid gland and palpitation of the heart, although one or another of these symptoms may be absent occasionally. In addition, there are usually numerous other nervous symptoms, marked nervous exhaustion and irritability. All the more recent investigations indicate with increasing certainty that the disease is very probably located in the upper part of the cervical cord and in the medulla oblongata. The affection is probably a functional neurosis; at all events, it presents generally a tendency to recovery, although sometimes followed by permanent sequela.

Electrical treatment must be directed to the cervical cord and the medulla oblongata; applications to the sympathetic and pneumogastric may also be made in order to combat the principal symptoms.

The galvanic current is employed almost exclusively. Above all, the application of ascending stabile and labile currents to the cervical cord; An between the scapulae, Ca in the neck and along the entire cervical spine; very feeble currents (6 to 8 Stoehrer's elements) are recommended for one or two minutes. At the same time, I have often passed the current transversely and obliquely through the head, in order to affect the medulla oblongata directly; also with very feeble currents of short duration. Finally, regular galvanization of the sympathetic and pneumogastric in the neck in the ordinary manner; the An upon the cervical spine, the Ca upon the nerves from the lower jaw to the clavicle. When the affection was supposed to be located in the sympathetic, this method was adopted almost exclusively by certain observers, and furnished numerous good results (Moritz Meyer). This application is said to be especially efficacious when the heart's action is violent and abnormally frequent.

Direct galvanic applications have been made in this disease to the enlargement of the thyroid gland, and with success in some cases; transverse passage of the current through the tumor or a brief, and, not too feeble, application of the Ca is advisable.

To relieve the exophthalmus I have repeatedly employed transverse conduction of a feeble galvanic current through the orbits, from temple to temple, and, at the same time, longitudinal conduction from the neck to the closed lids—whether with real benefit I do not venture to decide.

The ordinary methods of application are employed in the pareses of the ocular muscles, which are present in almost all severe cases.

The undoubted close relations of Basedow's disease to neurasthenia, and the ordinary occurrence of neurasthenic symptoms may lead very readily to the use of the methods, such as general faradization, ordinarily employed in the latter disease.

As a matter of course, the medicinal, dietetic, and balneological treatment of the affection should not be neglected.

The results of galvanic treatment in Basedow's disease are by no means bad. A reduction in the frequency of the pulse is not infrequently noticeable forthwith, or it may occur gradually during the course of treatment. But the entire symptomatology is often very rapidly improved, and the subjective complaints of the patient relieved. As a rule, however, the treatment must be continued for a long time (thirty to one hundred sittings or more). The exophthalmus often persists for a very long time, and defies all treatment; this is less true of the enlargement of the thyroid gland.

15. *Vertigo*.—Little can be said with regard to the electrical treatment of vertigo. In the large majority of cases it is merely a symptom of the most varied diseases, both of the central nervous system, as well as the vasomotor nerves, and, perhaps, also of other organs (reflex vertigo, including stomachal, ocular, labyrinthine vertigo, Menière's disease, etc.). The main feature in all these cases is the treatment of the primary disease; vertigo will rarely be treated as an isolated symptom in these affections.

Not infrequently, however, vertigo does occur, to a certain extent, in an isolated manner and constitutes the principal, and, to the patient, most striking symptom. Cases are not infrequent in practice in which we are consulted with regard to vertigo, while careful examination reveals no special abnormality, and the cause and pathogenesis of the symptom remain obscure. In such cases the vertigo may be treated by electrical applications. As the intracranial organs are the immediate points of origin of vertigo, galvanic and faradic applications may first be made to the brain, and then galvanization of the sympathetic. When symptoms of circulatory disturbances within the skull are present, the cerebral circulation may be influenced in a reflex manner by the farado-cutaneous brush.

16. *Diabetes mellitus and insipidus*.—Electro-therapeutic measures have been adopted very little in diabetes mellitus, and, as it seems, with very poor success; my own results have been entirely negative. Neffel, however, reports a very favorable result in a woman who had suffered for several years from advanced diabetes (nine per cent. sugar under mixed diet) and in whom galvanization of the brain (according to Neffel's method) produced remarkable improvement, so that all the subjective symptoms disappeared, and the amount of sugar sank to one per cent.

Beard reports improvement in two cases from central galvanization ; Le Fort reports considerable improvement from the permanent application of a feeble current of two elements from the neck to the liver.

The methods of application follow naturally from the current theoretical views concerning the development of neurotic diabetes mellitus : treatment of the cervical cord and medulla oblongata in the ordinary manner, and likewise galvanization of the sympathetic ; feeble currents for a few minutes daily.

The electrical current has been employed much more frequently in diabetes insipidus, and a few successful cases which have been reported should stimulate us to further attempts. Seidel reports a favorable result in a case which had lasted more than a year ; energetic galvanization of the region of the kidney produced very rapid improvement and in the course of a few weeks recovery, with an increase in the weight of the body. Althaus reports a recovery in a long-standing case from a single application to the medulla oblongata.

Treatment should be directed mainly to the central nervous system (the medulla oblongata and cervical cord) and also to the region of the splanchnic nerves, the dorsal cord and sympathetic ; galvanic applications should first be resorted to. Seidel made his application directly to the region of the kidneys ; one electrode (which?) was placed in this region, to one side of the spinal column, the other was pressed deep into the hypochondrium, anteriorly at the same level ; a strong galvanic current was applied for five minutes on each side.

General faradization or central galvanization may be advisable in some cases.

I myself have made an entire series of experiments in diabetes insipidus, but my results have been negative.

X. DISEASES OF THE ORGANS OF SPECIAL SENSE.

LECTURE XXXII.

Introduction—Diseases of the Visual Apparatus: Their Electro-diagnosis—Diseases of the Lids, Conjunctiva, Cornea, Iris, Lens, Vitreous Body, Choroid—Diseases of the Retina and Optic Nerve: Retinitis Pigmentosa; Papillitis and Papillo-retinitis; Optic Neuritis; Cases; Method of Treatment—Atrophy of the Optic Nerve: Tabetic and Genuine Atrophy; Cases; Treatment—Amaurosis without Anatomical Lesion—Hemianopsia—Diseases of the Ocular Muscles: Insufficiency of the Interni; Accommodative Asthenopia; Mydriasis; Nystagmus.

With reference to the organs of special sense, electro-therapeutics naturally deals mainly with the purely nervous affections of these organs; that it may also be employed in other forms of disease will be indicated in brief in the following section.

I will begin with the visual apparatus. The remarkable development of ophthalmology in the last few decades has thrown into clear relief the great importance of diseases of the eye, not alone in practice but also with reference to pathology. Particularly the so-called nervous affections of the eye, both those which affect the true sensory apparatus, the optic nerve and retina, and those involving the neuro-muscular apparatus, have acquired the greatest importance in neuro-pathology. Neurologists recognize this fact more and more from day to day, and the great frequency of nervous diseases of the eye as prodromata, part-symptoms and sequelæ of many important affections of the nervous system and also of some other general diseases, has led to special study and treatment of these diseases on the part of specialists.

As a matter of course, electro-therapeutics has also been relied upon for these objects, but its part in the treatment of nervous diseases of the eye is still comparatively slight, and is probably underestimated by many. Still slighter is its significance in the treatment of all non-nervous affections.

The actions of electrical currents in diseases of the eye are similar to those in diseases of the central and peripheral nervous system which have been so often described. The undoubted relations which exist between

the cervical sympathetic and cervical spinal cord on the one hand, and the structures within the orbit on the other, and the influence which appears to be exerted by the trigeminus upon the circulation and nutrition of the eye, should be borne in mind in the consideration of electro-therapeutic methods.

I will now describe the treatment of the individual forms of disease, so far as they are amenable to the action of electrical currents.

Very little can be said with regard to *diseases of the lids and conjunctiva*. Dutrait treats certain forms of entropium and ectropium, which he attributes to atony and atrophy of individual bundles of the orbicularis palpebrarum, by careful faradization of these muscular bundles. A fine electrode is employed, and those bundles, whose contraction produces restoration of the false position of the lid, are treated patiently for a long time.

Rodolfi has found the dynamico-chemical effects of the galvanic current useful in *trachoma*. He applies the Ca in the form of a copper olive-tipped sound to the granulations of the everted lids, while the An (a moistened sponge electrode) is placed upon the inferior maxilla (current from two Bunsen's elements). The results were very satisfactory in a series of cases, the granulations disappeared after a few sittings, but relapses were not entirely prevented. Rodolfi attributes Arcoleo's bad results in this disease to his defective method. Smith has also recommended catalytic treatment of *trachoma*. He applied both electrodes, in the shape of suitably bent wires separated about five millimetres from one another, directly upon the conjunctiva (current from two elements, one half to one minute upon each lid).

Diseases of the cornea were treated electrically by Arcoleo almost exclusively by means of the faradic current. The positive pole is placed on the neck or hand, the negative (in the shape of a small sponge or brush) directly upon the conjunctiva and cornea, or upon the closed lids by means of a broad sponge; Arcoleo employed the galvanic current very rarely. Daily sittings were held, lasting five to eight minutes. Very good results were obtained in parenchymatous keratitis (application of the brush to the conjunctiva, atropine being introduced sometimes). The cornea began to clear up after a few sittings and more or less complete recovery gradually ensued. A brilliant result was obtained in a case of epithelial keratitis. He also states that very good results were obtained in corneal ulcers by the same method, the bottom of the ulceration being touched lightly with the hair brush two or three times during each sitting. In one very old case of whitish opacity of the entire cornea I employed this method for a very long time without noteworthy effect, but it did not yield to any other method of treatment. In one case of beginning neuro-paralytic keratitis and conjunctivitis (*vide* Observation 132), due to paresis of the left trigeminus, I observed decided benefit from galvanic applications to the eye (Ca stabile and labile upon the closed lids). Brière reports a recovery in parenchymatous keratitis in a few weeks from galvanic applications (4 to 6 elements) and Chvostek had admirable results in a case of keratitis pannosa from persistent galvanization of the sympathetic.

Among *diseases of the iris*, apart from its nervous affections, hypopyon appears to be the only one which has been repeatedly made the subject of electro-therapeutic experiments. Arcoleo speaks very highly of the faradic

currents ; a fine sponge electrode is applied directly to the lower border of the cornea, and touches the region of the purulent deposit three or four times during the course of the sitting ; after the sitting atropine is applied and this is followed by congestion of the conjunctiva. Marked diminution of the hypopyon is said to become apparent upon the following day ; mild cases are said to have been cured in a single day, more severe ones in four to seven days (twenty cases). Weisflog has also observed very good effects from his method of faradization (large sponge electrodes upon the closed lids, six to eight half hourly sittings daily) in five cases of hypopyon, and also reports an extremely rapid recovery in a severe, acute iritis from three hourly faradizations daily.

Among *diseases of the lens* cataract has been drawn recently into the domain of electro-therapeutics. Nefel created no little excitement in the ophthalmological camp by a report of two case of undoubted beginning cataract in which all the symptoms of cataract were relieved by methodical galvanic treatment and the visual power restored completely. After a sharp criticism of these statements by Hirschberg, Nefel acknowledged that the opacities in the lens, demonstrable with the ophthalmoscope, had not disappeared entirely, and explained the undoubted improvement of the eyesight to the removal of a molecular opacity, which was not recognizable upon ophthalmoscopic examination. He adds also that galvanic applications exert an influence, though not to a great extent, upon the opacity of ripe cataracts.

This subject is, therefore, still in its infancy, but its great importance justifies further careful experiments, mainly with reference to beginning cataract.

The following is the method employed by Nefel: An stable in the neck, Ca stable and labile upon the closed lids ; begin with five elements ; then pass the current in the opposite direction. This procedure should be repeated, with an increment of one element, until fifteen elements are reached ; duration of sitting ten to fifteen minutes, at first daily, then less frequently.

The electrical current has been employed, and not without success, in *diseases of the vitreous body*, especially opacity. As is well known, opacities may be produced by various morbid processes and thus possess a variable pathological significance. They may be due to extravasations of blood, inflammatory products, degenerative processes, pus, cicatrices, etc.

Giraud-Teulon appears to have devoted most attention to the galvanic treatment of these forms of disease. In a preliminary communication, he has stated recently that the galvanic current is the most effective and rapid curative measure in the majority of opacities of the vitreous, and Onimus has also published a series of favorable reports. Boncheron and LeFort have also reported some cases.

From the observations made by these writers, there seems to be no doubt that the galvanic current exercises a certain influence upon opacities of the vitreous, and that rapid and more or less complete recovery may be effected by means of its employment in not a few cases, which had long been treated without benefit by other remedies.

The methods employed by different authors vary greatly. Le Fort makes constant application (both day and night) of the electrodes of two feeble elements to each temple ; Giraud-Teulon applies the An of 8 to 10 Daniel's elements to the closed lids, the Ca behind the ear, for two to four minutes ; Onimus applies the Ca to the closed lids, the An to the

corresponding sympathetic, 8 to 12 elements, stable, for two to five minutes. It follows, therefore, that the essential feature is merely the passage of the galvanic current through the eye, and this conclusion agrees with our general notions concerning the production of catalytic actions. For future trials I would recommend the passage of a current from the closed lids to the back of the neck, with a change in the direction of the current, either the poles being alternated at each sitting or the An alone being employed in one sitting, the Ca in the next; feeble currents (4 to 10 Stoecher's elements), stable application for two to five minutes.

Dor reports some very encouraging results in *diseases of the choroid*. The most suitable cases for electrical treatment are said to be those in which, after a disseminated choroiditis, atrophic changes develop in the retina with scotoma, etc., after the lapse of months or years, and those in which there are numerous accumulations of pigment, plastic exudation and spots of atrophy. He treats them with the galvanic current transversely through the temples, or, in a unilateral affection, from the supra-orbital arch to the mastoid process of the same side.

140. *Observation by Dor. Chronic retino-choroiditis.*—A man, aged thirty-six years. Sick for two years; treated unavailingly with all possible remedies (venesection, mercury, iodide of potassium, diaphoresis, issue, baths, etc.); must be led around. Diagnosis: disseminated choroiditis with numerous accumulations of pigment and secondary changes in the retina; papilla somewhat reddish, sharply defined. Large central scotoma on both sides. V. on both sides, No. C in the immediate vicinity. At first treatment with Heurteloup's, and improvement to $\frac{1}{11}$ (with excentric fixation); then stationary condition. Galvanic treatment: after three weeks, patient reads all letters in VII, some in VI. Intermission of five months; reads letters of VII. Strychnine for a week, without change. Galvanic current: after two days, letters of VI; after a week, of IV.; six weeks later, reads all letters of III.; improvement in right eye alone, the scotoma diminishing steadily. After May 29th central vision (No. XL.) possible. July 8th, No. XX.; August 24th, No. V. The left eye, which was affected first, did not show improvement until after forty-five days electrical treatment (May 29th). July 18th, left eye, No. XV. (excentric); August 24th, No. VI.; the central scotoma markedly smaller.

The diseases of the retina and optic nerve are by far the most important to the electro-therapeutist, partly on account of their frequency and pathological significance, partly also on account of the numerous good results effected by the electrical current in these affections, especially in the simple inflammatory processes and their sequelæ, furthermore in purely functional disturbances without anatomical change, to a less extent in primary degenerations and atrophy.

Dor has obtained very good results in a number of cases of *retinitis pigmentosa* by means of the galvanic treatment described above; Neftel also reports a favorable result.

In *papillitis and papillo-retinitis* (usually called choked disc), as it occurs in so many diseases within the skull, especially in tumors and meningitis, much cannot be expected from electrical treatment (although Driver states

that he has seen good results from galvanization of the sympathetic in this symptomatic neuro retinitis) so long as the process is progressing and the primary disease is not relieved. But it may be hoped (and individual observations favor this view) that the electrical current may prove very useful and produce considerable improvement of vision in the sequelæ of this disease, after the termination of the primary affection; the treatment is then the same as in every optic neuritis with secondary atrophy.

Optic neuritis in its various forms and terminations is probably the most grateful object for electrical treatment among all the anatomical affections of this nerve.

In optic neuritis and atrophy of the optic nerve, Pflueger has seen a number of good and, in part, brilliant results from galvanic treatment, but furnishes no details concerning the method of application.

Leber recommends treatment of the sympathetic in the congenital affections of the optic nerve described by him, and which are known as retrobulbar neuritis (*vide* Observation 49, page 184). In a number of similar cases, however, this favorable result was not obtained.

In a case of descending optic neuritis, followed by amblyopia with the ophthalmoscopic appearances of atrophy of the optic nerve, associated with transverse dorsal myelitis, I obtained a very satisfactory result from repeated galvanic treatment.

141. *Personal observation. Optic neuritis and subacute dorsal myelitis.*—A man, aged fifty-two years, in February, 1877, became blind quite rapidly in the left eye, sight being restored after a few weeks; shortly afterward, a similar affection of the right eye, followed by improvement. After some time, relapse in both eyes advancing to complete amaurosis; ophthalmoscope shows distinct appearance of optic neuritis with beginning atrophy. Slow improvement from the middle of June. At the end of June, symptoms of transverse dorsal myelitis which led (end of July) to complete paraplegia, with anæsthesia, paralysis of the bladder, increased tendon and cutaneous reflexes, etc. Improvement in all these symptoms from beginning of August, 1877; at the end of September, patient can walk a few paces. Slow progress of improvement in sight.

November 12, 1878.—After the sight had remained stationary for a long time, galvanic treatment was begun. Status on this day: pupils quite small, react to light; slight myopia of both eyes; R. E., V. $\frac{5}{6}$; L. E. somewhat less, V. $\frac{2}{3}$. With + 3, right, J. No. 3; left, J. No. 6, slowly recognized in a few words. Both eyes blind to red and green. Atrophy of both optic nerves with slight atrophic excavation, more marked on left side. Method of treatment: 4 to 6 Stoehrer's elements transversely through the temples, 6 to 8 elements, from the neck to eyes, stable, three to four minutes daily. December 10th: both eyes undoubtedly better. March 4th: R. E., V. $\frac{7}{8}$; L. E., V. $\frac{3}{4}$. With + 3, reads J. No. 3, and some words of No. 2; with + 4 and 5 reads newspaper print readily. Treatment discontinued. Similar treatment repeated at a later period produced no noteworthy improvement, but the patient can now write and read ordinary print.

142. *Observation by Rumpf. Optic neuritis with transverse myelitis.*—A

woman, aged thirty-seven years. Sick about two years; paresis of lower limbs, totters on closing the eyes; paræsthesiæ, diminished sensibility of legs, cincture feeling, increased tendon reflexes, incontinence of urine. Impaired vision (reads J. No. 14 with difficulty). Ophthalmoscope shows appearances midway between choked disk and optic neuritis, viz., swelling, cloudiness, intense injection of papilla, dilatation of arteries and veins. Treatment with the faradic brush (vigorous, slow strokes over the chest, back, and upper limbs). Result very brilliant; injection of nerve slighter on third day, then the swelling of the papilla diminished; J. No. 7 could be read on the sixth day. After twenty-eight sittings, the symptoms of myelitis disappeared; patient now reads J. No. 3; ophthalmoscopic appearances normal.

143. *Personal observation. Neuritis with atrophy of the optic nerve.*— A man, aged twenty-one years. Came under treatment December 2, 1880, for amblyopia, which had existed for several months and had developed quite rapidly. Ophthalmoscope shows optic neuritis with transition into atrophy; marked amblyopia, can scarcely count figures; field of vision considerably narrowed. Treated with extract nucis vomicæ, and galvanic current; 6 elements transversely through the temples, 6 to 8 elements from the neck (An) to the closed lids (Ca stabile and labile), also to the cervical sympathetic two to three minutes daily. January 10, 1881, patient states that sight is decidedly improved; with the left eye recognizes upon Snellen's tables the letters from D = 9 very well, D = 6 in part; with right eye, D = 9 only in part. Colors: green very uncertain, red quite so, blue and yellow distinct, but not entirely normal. The ophthalmoscopic appearances better. February, 27th: L. E., D = 1 very well; R. E., a few letters of D = 4; patient can read a few words with the left eye; field of vision still very small, he is again able to walk alone upon the street. March 24th, left for Switzerland. Returns improved two months later.

I have incomplete notes also of several other cases in which galvanic treatment was useful, at least to a certain extent, but I must also mention an entire series of negative results. Benedikt also reports a number of favorable results in neuro-retinitis and optic neuritis.

The method of treatment readily follows, from the indications which are presented; as catalytic action is required, stabile currents will be employed in the main and should be applied as directly as possible to the eye and optic nerve. In the first stages the An is preferably applied to the eye; later, when the process is tending toward atrophy, the predominant action of the Ca is more desirable. In addition, galvanization of the sympathetic is sanctioned both by experience and by anatomical and physiological considerations. Large electrodes, feeble currents, short sittings (not more than two to five minutes) are recommended.

In detail, then, the applications should be made as follows: first, transverse passage of the current through the temples with a variable direction of the current, in order to reach the optic nerve within the orbit; then longitudinal conduction from the neck to the closed lids (when neuritis predominates, the An chiefly on the eye, the Ca for a short time and sta-

bile ; after atrophy has occurred, the Ca chiefly on the eye, after the application of the An, stabile and moderately labile). Finally, galvanization of the sympathetic according to the ordinary methods.

Numerous observations prove, even at the present time, that decided benefits are obtained by this method. It is often found that the results are much better with regard to vision than the ophthalmoscopic appearances ; the most exquisite white atrophy may be present, although vision is tolerably fair.

The results of electrical, as of other treatment are much less encouraging in *primary atrophy of the optic nerve*, in which an inflammatory initial stage is not demonstrable, but we have to deal from the start with a degeneration of the nerve. These are the gravest forms of optic nerve disease, and only in very exceptional cases does a stand-still or regeneration occur ; however, treatment is not entirely useless and many observations make it our duty not to weary in our therapeutic endeavors in this field.

This is especially true of optic atrophy in locomotor ataxia. It is extremely frequent and important, because it often occurs early in the history of this disease and many years may elapse before the development of other symptoms. But this is not often the case, and since we have learned recently to recognize the earliest beginnings of ataxia, we will be able not infrequently to attach the proper pathological significance to the affection of the optic nerve from the presence of lancinating pains, reflex rigidity of the pupils, slight analgesia and especially the absence of the tendon reflexes. The disease manifests itself by diminution of the power of sight and the sense of color, contraction of the field of vision, and progressive amblyopia with the characteristic ophthalmoscopic appearances.

It goes without saying that it is important to treat the very onset of the disease, as then alone is there any hope of maintaining the power of vision. But even then the results are very slight or entirely negative, and I have repeatedly seen the affection progress uninterruptedly from the very beginning to complete amaurosis.

Nevertheless, there are a few cases which teach us that a stand-still or even more or less considerable improvement may be effected—and this also holds true of the coincident affection of the posterior columns of the spinal cord. I have treated a case of this character, of which, unfortunately, I do not possess any accurate notes. The patient was an officer, aged forty-six years, who had suffered for twelve years from the initial symptoms of tabes, and for two and a half years from atrophy of the optic nerves with considerable limitation of the field of vision in both eyes. Galvanic treatment for a month produced considerable enlargement of the field of vision ; central vision had also improved in both eyes.

The method of treatment is the same as that described above for

neuritic atrophy. But it is important in such cases to treat the spinal cord at the same time.

The results in the not very infrequent so-called *genuine atrophy of the optic nerve* are somewhat less unfavorable. It occurs from unknown causes without any demonstrable connection with spinal or cerebral diseases, and is entirely analogous to the "white optic atrophy" of ataxia in the functional disturbance and the ophthalmoscopic appearances. Some very favorable results of galvanic treatment in this form have been reported.

144. *Observation by Driver. Atrophy of the optic nerves.*—A teacher, aged twenty-four years. Eye trouble for years; amblyopic; treated in various ways without success. Examination shows exquisite atrophy of both optic nerves with superficial excavation; vessels extremely narrow; nystagmus. With right eye sees finger at four feet, with left eye at three feet. Contraction of field of vision; Daltonism. Treatment for three weeks with injections of strychnine; stand-still. Then galvanic treatment; at end of two months patient counts fingers at twenty feet. Treatment continued at home; a year later reads Sn. No. 8 and recognizes all colors. Ophthalmoscopic appearances distinctly improved; vessels larger.

145. *Observation by Driver. Beginning atrophy of the optic nerves.*—A woman, aged forty-five years. Left amaurosis for considerable period; recently noticed mist in front of right eye; otherwise healthy. Ophthalmoscope: left eye, exquisite atrophy of optic nerve; right eye, papilla somewhat whiter, vessels smaller than normal. $V. = \frac{2}{3}\%$; field of vision and color sense normal. After galvanic treatment for three weeks, R. E., $V. \frac{3}{4}\%$, mist disappeared, ophthalmoscopic appearances normal; L. E., finger visible at two feet above and to the outside. Relapse at end of half a year. R. E., mist again present, $V. = \frac{2}{3}\%$. Complete recovery after galvanic treatment for twelve days.

146. *Personal observation. Beginning atrophy of the optic nerves.*—A man, aged forty-eight years. A drinker, suffering for eight months from diminution of power of vision, and frequent headaches. R. E., $V = \frac{6}{8}\%$; L. E., $V = \frac{6}{8}\%$. Binocular, J. No. 13 at seven inches. Normal tension of eyeballs, reaction of pupils normal; refracting media clear. Papillæ brighter than normal, not sharply defined; vessels quite well filled; field of vision and color sense normal. Galvanic treatment: 8 to 10 elements transversely through the temples and mastoid processes; also from the neck to the eyelids, with variable direction of the current. Considerable improvement in a few days; head freer, pain disappeared, sight considerably better. After two weeks' treatment, examination shows: R. E., $V. = \frac{7}{8}\%$; L. E., $V. = \frac{6}{8}\%$; binocular, J. No. 6.

147. *Observation by Dor. White atrophy of the optic nerves.*—A lady. Unable to walk alone; with great difficulty sees a few letters of Sn. LXX. at very short distance; suffering for two years, first in right, then in left eye. White atrophy of both optic nerves. Frequent headache. Artificial leeches and iodide of potassium produced improvement, so that she could read Sn. XX.; then stand-still. Then application of faradic current; in a week could read Sn. XV., in two weeks a letter of VIII., in three weeks of VI.; no further improvement. Patient returned at end of

seven years; slight relapse, but only to $\frac{1}{xx}$. Application of galvanic current (October 6, 1871). October 28th, $\frac{2}{viii}$; patient then discontinued treatment, but improvement remained permanent.

148. *Observation by Dor. White atrophy of the right optic nerve.*—A man, aged forty-six years. Right eye affected for six weeks; shows distinct white atrophy. $V. = \frac{2}{c}$; very narrow field of vision. Galvanic treatment. In a week, $V. = \frac{2}{c}$, but field of vision distinctly enlarged; in two weeks $V. = \frac{1}{lxx}$; field of vision again enlarged. Patient then continued the treatment at home, and writes that sight improved to such an extent that he finally discontinued treatment.

These cases prove that the galvanic current possesses a considerable curative power in those otherwise hopeless diseases of the optic nerve, which are manifested in the form of so-called white atrophy. From a considerable number of observations, Dor concludes that at least forty to fifty per cent. of these cases may be really and notably improved.

The method of treatment is the same as that which I have described above for secondary atrophy. As the duration of the process increases, an increasingly intense action of the Ca may be recommended.

The electrical current also appears to possess a favorable influence in *amblyopia and amaurosis without anatomical lesion*. But different authors express very different opinions. Driver has seen scarcely any good results, while Boucheron, Secondi, Arcoleo, Seely, and others report favorably.

We have to deal here with amblyopias from nicotine, alcohol, and lead poisoning, spontaneous and traumatic anæsthesia of the retina, hysterical amaurosis and amblyopia, amblyopia ex anopsia, and hemeralopia.

149. *Observation by Boucheron. Cerebral scotoma.*—A man upon waking in the morning noticed a disturbance of vision in the left eye, which has since increased. Central scotoma; can read J. No. 19. Ophthalmoscopic appearances negative. On the eighth day, application of a feeble permanent galvanic current, 2 elements Trouvé for six hours; J. No. 8 can then be read. Daily repetition of the application; in four days, J. No. 1 can be read at 15 centimetres. Complete recovery.

150. *Observation by Boucheron. Convergent strabismus; marked amblyopia of one eye.*—A boy, aged seventeen years. Admitted January, 1875, with marked convergent strabismus and nystagmus; is operated upon on both sides with good results. February, 1875, marked amblyopia of left eye still present; with difficulty reads Sn. L. at 10 centimetres. Application of feeble continuous current from 2 Trouvé elements, An on the forehead, Ca on the neck; during the entire night and sometimes a few hours during the day. In ten days, patient reads Sn. No. XXX.; a week later, No. XX.; four days later, No. XV. Treatment discontinued until March 2d, then resumed until March 8th, when he could read No. XII. and even No. X.

151. *Observation by Secondi. Traumatic anæsthesia of the retina.*—A girl, aged sixteen years. Suffered a contusion of the eye; no lesion, except an ecchymosis of the bulbar conjunctiva. $V. \frac{1}{4}$. Sight had diminished

at once after the accident. The pupil is less mobile than on the healthy side. Galvanic treatment: Ca labile to the lids, An to the neck. Recovery after three sittings.

Arcoleo reports very favorable results in hemeralopia. He distinguishes two forms, an organic form, with visible anatomical changes, and a functional one; the electrical current is especially useful in the latter, the results being "so to speak unailing." Considerable improvement also occurs in some organic forms. He employs the faradic current alone, the Ca to the closed lids, the An to the neck for five to ten minutes. Recovery sometimes follows a single sitting, and there is usually improvement, at least, after two to four sittings.

Hemianopsia, which has been made recently the subject of interesting physiological and pathological discussions, may also become an object of electrical treatment. I have under observation, at the present time, a case which developed coincidentally with a left hemiplegia, in which galvanic examination reveals in both eyes a field of light which represents but half of a circle and corresponds accurately to the shape of the remaining portion of the field of vision. As hemianopsia, at least in the homonymous lateral forms, is never due to a disease of the eye but always to an affection of the optic tract or brain, direct applications to the eye should be omitted, as a rule, and the treatment confined to the primary affection according to well-known methods.

Finally, it remains for me to say a few words concerning *affections of the ocular muscles and their nerves*. The most frequent and important ones, viz., the paralyzes, have been discussed with sufficient detail in a previous lecture (Lecture XXII, p. 198). I will here say a few words with regard to those paretic conditions of individual muscles which belong almost exclusively in the domain of the oculist—above all, the so frequent muscular asthenopia which is due to insufficiency of the internal recti and in which very favorable results have been secured by means of the galvanic current. The method of application should be that recommended on page 198.

Electricity has also been recommended in accommodative asthenopia and in mydriasis, but recovery is often very long in making its appearance.

In disturbances of the pupillary reflexes, the galvanic current has been entirely useless hitherto in my hands.

Very little can be said concerning spasmodic affections of the eye. Blepharospasm has been discussed previously on page 270; the galvanic current (stable from the mastoid process to the eye, one to two minutes daily) has been employed successfully in acquired nystagmus by Soetlin and Nieden. Very little can be done in congenital nystagmus, and in that due to multiple sclerosis, hereditary ataxia, etc.

LECTURE XXXIII.

Diseases of the Auditory Apparatus—Introduction—Dryness of the Auditory Canal—Opacities of the Membrane—Diseases of the Auditory Nervous Apparatus: Nervous Tinnitus Aurium; Its Relations to Galvanic Reaction; Electro-diagnosis; Therapeutic Indications; Determination of the Method of Treatment; Cases; Principles of Treatment; Special Procedures in Individual Cases; General Rules and Technical Remarks; Results—Nervous Deafness; Cases; Method of Treatment—Deaf-mutism—Menière's Disease—Neuroses of the Gustatory Nerves; Ageusia—Neuroses of the Olfactory Nerves: Anosmia and its Treatment.

I now arrive at the consideration of the auditory apparatus. Numerous attempts have been made for many years to relieve patients suffering from ear troubles by means of electrical currents. Many of these attempts were not fruitless, but the condition of otology as well as of electro-therapeutics did not admit of exact scientific progress in this department.

This dates from Brenner's admirable investigations, which have secured for the galvanic current an important domain in the treatment of diseases of this organ.

Nervous diseases of the ear alone have been subjected hitherto to electrical treatment. But such affections are frequent; the labyrinth and auditory nerve are primarily affected not infrequently, and still more commonly disturbances in the nervous auditory apparatus complicate diseases of the conducting apparatus. That annoying and distressing symptom, tinnitus aurium, is especially common, and is in many instances of purely nervous origin, in others not at all, or can be attributed only in part to a nervous disorder. Every expert knows how difficult it often is to remove this symptom, and how powerless otology is, especially its favorite mechanical methods of treatment. In these very forms of disease, however, the electrical current, especially galvanism, is very often curative and not infrequently diminishes the accompanying deafness with the relief of the subjective noises. Not uncommonly the results in this field are really brilliant, after all other methods of treatment have failed. Nor do they depend merely on chance, but are obtained upon the basis of methodical diagnostic examination and the consequent scientific determination of the therapeutic indications. This is proven by numerous incontrovertible facts.

In addition to nervous ear diseases, a few other pathological conditions of the organ may be successfully subjected to the influence of electrical currents.

1. *Abnormal dryness of the external auditory canal*, associated with an annoying feeling of coldness, heaviness, and lifelessness of the entire ear, produced by deficient secretion of cerumen, occurs in many chronic ear diseases. The action of galvanic currents, especially when introduced by means of a suitable electrode into the auditory canal filled with water, usually removes this symptom very rapidly and effectually, according to Brenner's and Hagen's experience; probably by acting upon the blood-vessels and secreting glands. The auditory canal again becomes flexible and moist, the secretion of cerumen returns, and the normal sensation of these parts is restored.

2. *Opacities of the tympanum*, which, as is well known, are extremely common, always depend upon the deposit of pathological products, although these may vary greatly in character. The frequently observed fact that an intense congestive condition of the tympanum may be produced by the action of galvanic currents upon the ear (and is characterized by marked injection in the region of the handle of the hammer) led Brenner to make use of this phenomenon for the absorption of certain opacities of the tympanum. This idea was confirmed by experience, and Hagen has reported a series of similar observations. The method consists in the introduction of an electrode into the external auditory canal (filled with water) and the stable application of galvanic currents of a variable direction, so that both poles act alternately. As a matter of course, great patience is required in this method, especially if the opacities are very old. In a number of cases, however, Hagen has seen the opacity disappear or diminish very considerably after twelve to twenty sittings, and Hedinger has had similar results.

3. *Diseases of the auditory nervous apparatus itself*.—By far the most important, from a practical point of view, are the morbid subjective noises in the ear or nervous *tinnitus aurium*.

This is very common, extremely annoying and depressing to the patient, disturbs sleep and temper, is associated with disagreeable sensations in the head, diminishes the desire and capacity for work, and is felt usually much more severely by the patient than the difficulty in hearing or deafness ordinarily associated with it. This condition is very often inaccessible to all otological treatment, so that there is no doubt of its great practical importance, and we must therefore regard it with a double satisfaction that a very important auxiliary measure against this obstinate and serious disease has been found in the galvanic current.

I have already laid sufficient stress upon the great importance of the galvanic current for the more accurate diagnosis of these subjective auditory sensations (Lecture XI, p. 96). It was then found that the results of galvanic examination differ greatly in cases of subjective noises in the ear. The most common reaction is simple galvanic hyperæsthesia, increased not infrequently to the "paradox reaction;" or hyperæsthesia is

manifested with various anomalies of the normal formula up to its complete reversal, or simple anomalies of the normal formula without hyperæsthesia, etc. But there are numerous cases in which galvanic examination shows no anomalies in the reaction of the auditory nerve. On the other hand, it has been proven that the galvanic current not infrequently exercises a direct modifying influence upon the subjective noises; that in a series of cases the tinnitus is diminished by the action of the current, or entirely stopped, at least by certain factors of the stimulus, while it is increased by others. As a rule, An C1 and An D, to a slighter extent Ca O, exercise this inhibitory influence upon the tinnitus (as in almost all cases of simple galvanic hyperæsthesia). But it sometimes happens that Ca Cl and Ca D lessen the noise, especially in hyperæsthesia with reversal of the normal formula, but occasionally when the formula is qualitatively normal. In another series of cases the tinnitus is not affected in any manner by the current, and finally, there are certain mixed forms with two or more noises, in which one or more of these noises may be lessened or abolished by the current (usually by An D), while the other is entirely uninfluenced. This indicates a difference in the mode of development of these noises.

The most important point in practice is to determine whether the affection is of nervous origin or not.

If there are distinct anomalies in the galvanic excitability of the auditory nervous apparatus, we may at least suspect that the affection is due entirely or in part to a disease of the nerve. This is rendered extremely probable if the tinnitus can be distinctly modified by the galvanic current, especially if it is lessened by An D.

On the other hand, its nervous origin is very improbable when no anomaly can be found in the galvanic excitability of the auditory apparatus, or the galvanic current produces no modification of the tinnitus. However, its nervous origin is not excluded absolutely thereby, and though such cases present very little chance of therapeutic success, the therapeutic experiment alone can decide positively with regard to its curability or incurability by means of the galvanic current.

The determination of the method of treatment depends solely upon the formula of galvanic reaction, with reference to the ameliorating influence of the current upon the tinnitus. At least, this statement is true, with scarcely any exception, of the simple and uncomplicated cases of simple hyperæsthesia with tinnitus aurium. It is perhaps premature to regard the restoration of the normal formula as the direct object of treatment; the immediate effect of the current upon the noise itself must always be taken into consideration.

152. *Observation by Brenner. Simple galvanic hyperæsthesia with tinnitus aurium.*—A student, aged twenty-three years. Suffering from defect-

ive hearing, and constant, extremely severe tinnitus in both ears as the result of long-standing catarrh of the middle ear. Marked mental depression, interference with study. Watch heard at one inch on left side, two inches on right; the membranes thickened, very opaque; light spot very small on right side, absent on left; Eustachian tubes pervious on both sides; repeated treatment useless.

Successful electrical treatment of tinnitus a few months ago; relapse at present time in consequence of excessive mental work and excitement. Galvanic examination with very slight strength of current showed upon both sides:

Ca Cl, violent ringing.

Ca D, continued ringing.

Ca O, tinnitus stops for a little while, then gradually grows stronger.

An Cl, tinnitus disappears suddenly and completely.

An D, tinnitus remains absent.

An O, tinnitus returns with increased severity.

For purposes of treatment, each ear is armed with the An (Ca in the hand), the tinnitus abolished by An D with a relatively strong current, the strength of current then gradually diminished with the aid of the rheostat, and finally the circuit opened by withdrawing the Ca slowly from the hand; this was followed by complete cessation of the tinnitus. Permanent abolition of tinnitus after two more sittings; watch heard at four inches on left, six inches on right side.

153. *Observation by Brenner. Tinnitus aurium after administration of quinine; simple galvanic hyperæsthesia; recovery.*—A woman, aged thirty-three years. Had taken large doses of quinine for three weeks; then acquired an extremely annoying, incessant tinnitus aurium, which remained unchanged for past three months; moderate diminution of audition on both sides. Otological examination furnished negative results.

Galvanic examination showed moderate simple hyperæsthesia, and complete cessation of tinnitus at An Cl and An D. Treated with An D, and gradual diminution of current. After the first sitting, tinnitus remained absent for two hours; complete recovery after the fifteenth sitting; the head felt free, disposition cheerful, impairment of hearing had disappeared.

154. *Personal observation. Impairment of hearing and tinnitus aurium; bilateral hyperæsthesia of the acoustic nerve; paresis of the right abducens nerve.*—A man, aged fifty-nine years. Impairment of hearing and tinnitus aurium for six months, constantly on both sides; the noise sounds like ringing of bells or the boiling of water. Increasing vertigo for a month; diplopia for three weeks. Status on January 7, 1870: paresis of right abducens; chronic catarrh of middle ear; diffuse opacity of both membranæ with diminution of light spot; Eustachian tubes pervious; feeble conduction through the bones, better on right side than on left. Watch heard at eight inches on right side, five inches on left; after catheterization, at twelve inches on right, nine inches on left.

Galvanic examination shows simple hyperæsthesia in both ears; the noise disappears entirely during An D. Treatment consists of vigorous application of An D to each ear, with gradual diminution of current (also treatment of abducens paralysis). After ten sittings, abducens paresis very much better; tinnitus aurium decidedly less, and only occurs at times. Slow progress of improvement; after forty-four sittings, patient was discharged in following condition: diplopia almost entirely disappeared;

tinnitus aurium absent, except that it occasionally appears on left side; hearing slightly improved.

155. *Observation by Hagen. Tinnitus aurium and impairment of hearing; simple hyperæsthesia of both acoustic nerves.*—A man, aged forty-two. Tinnitus aurium and impairment of hearing six years ago after a cold, gradually growing worse. Right ear: membrane opaque, light spot absent; hears watch at nine inches. Left ear: membrane shows grayish white radiating streaks, light spot absent; hears watch at eleven inches. Tuning-fork heard equally well on both sides; pharyngeal catarrh. Tubes pervious. After continued otological treatment, could hear on right side at one foot, on left at one foot seven inches, but the subjective auditory sensations not improved.

Galvanic examination shows simple hyperæsthesia of both ears. Treatment with An D, and gradual diminution of the current. After sixteen sittings, tinnitus aurium entirely and permanently relieved; hears at four feet on right, and two feet on left side. Opacities of membranes gone, light spots distinctly visible.

156. *Observation by Hagen. Tinnitus aurium. Simple hyperæsthesia of the acoustic nerve.*—A woman, aged fifty-nine years. Suffering from threefold subjective auditory sensations in right ear, viz.: singing, whistling, and roaring; very hard of hearing in right side; membrana tympani very yellow, opaque, without light spot. Catheterism, air douche, and strychnine injections useless. Galvanic current shows simple hyperæsthesia. The roaring and whistling disappear during An D, singing unaffected. After a few sittings (An D) the roaring and whistling disappeared permanently but the singing noise was unchanged.

157. *Observation by Hagen. Bilateral tinnitus aurium and impairment of hearing; simple hyperæsthesia.*—A man, aged thirty-four years. Suffering from tinnitus aurium and impairment of hearing on right side for three years, on left for a year and a half. Right ear: moderate opacity of membrane, light spot dull, long arm of anvil not visible. Left ear: membrane grayish white in posterior quadrant, light spot dull, manubrium very short. Watch not heard on either side; very loud talking heard at one foot. Conduction through bones better on right side than left; tubes pervious. Symptoms not improved by catheterism. Galvanic examination shows marked simple hyperæsthesia on both sides. Application of An D and gradual diminution of current forthwith relieved the tinnitus in both ears so completely that a second sitting was unnecessary; the recovery was permanent (patient seen after several weeks).

158. *Observation by Brenner. Chronic buzzing in the head and tinnitus aurium with impairment of hearing; hyperæsthesia with paradox formula.*—A physician, aged fifty years, suffering since childhood from great difficulty of hearing and distressing subjective auditory sensations. Watch heard on right side upon applying it to the ear, not at all on left side; tubes pervious, membranes very cloudy, etc. In addition to the tinnitus aurium the patient also recognizes a deeper noise of a different character which he locates in the occiput; upon falling asleep, he hears detonations which are followed by twitchings. Galvanic examination shows enormous hyperæsthesia of both acoustics with paradox reaction of the unarmed ear. During An D, complete cessation of the buzzing in the head, but tinnitus aurium unaffected. Patient was treated with galvanism on a number of occasions for several months, with very favorable results. The buzzing in the head constantly diminished, the detonations upon falling

asleep gradually disappeared, hearing improved, the head felt free, disposition more cheerful, but the tinnitus aurium remained.

159. *Observation by Hagen.* Impairment of hearing and tinnitus aurium; hyperæsthesia with reversal of the normal formula.—A girl, aged seventeen years. Hard of hearing for three months, and subjective noises (roaring, singing, ringing of bells) on both sides, more marked on left. No cerumen on either side; membranes opaque, without light spot; tubes pervious; hears watch at four inches on right side, one inch on left. Otological treatment for several weeks proved useless. Galvanic examination showed following formula:

Ca Cl, ———
 Ca D, ———
 Ca O, feeble hissing.
 An Cl, loud hissing.
 An D, continued hissing.
 An O, ———

Ca D produced immediate diminution of the subjective noises. Treatment with Ca D and gradual diminution of current. After the eighth sitting the ringing alone returned at times; after the seventeenth sitting, this also remained permanently absent; hearing somewhat improved. The Ca O reaction in the galvanic formula disappeared, but the latter did not return to the normal. Recovery permanent.

160. *Observation by Moos.* Impairment of hearing and tinnitus aurium after cerebro-spinal meningitis.—A man, aged twenty-one years. Had cerebro-spinal meningitis in 1866, followed by complete deafness; later some improvement on left side, none on right; loud bilateral subjective noises. Summer of 1867, complete deafness of right ear; on left side, watch heard at three feet, but complete deafness for deep tones. Complete integrity of the mechanism of the auditory apparatus. Various methods of treatment useless. In left ear, formula of simple hyperæsthesia; subjective noises diminished by An D; after first sitting, watch heard at six feet. In right ear, loud hissings at Ca Cl, but no improvement by further treatment. On the left side, could understand speech at eighteen paces (before treatment at two paces) after twenty-two sittings and the subjective noises were considerably moderated.

The method of treatment which should be adopted can be readily determined from these cases. It may be laid down as a general principle that those factors of the stimulus, which diminish or abolish the subjective noise, should be applied with the greatest possible intensity and duration, and, on the other hand, those which increase the tinnitus should be diminished as much as possible or entirely avoided (by gradually diminishing or increasing the strength of the current).

In tinnitus aurium associated with simple hyperæsthesia, which is diminished by AnD, close the circuit with the An, in full strength, and then gradually diminish the current after a sufficiently long application of An D, in such a manner that "opening" stimulation is avoided. Not infrequently this must be done very slowly and cautiously, and a greater strength of current, must often be resorted to again, and the duration of the sitting prolonged, before an absolutely non-irritant diminution of the

current is rendered possible. If the action of the An D is to be increased by a preliminary change of polarity, close the circuit at the Ca, with a minimum strength of current, then gradually increase its strength, and finally change rapidly to An D.

But if the hyperæsthesia is so great that the paradox reaction is present, the proper method consists in arming both ears with one bifurcated electrode and then carrying on the treatment in the manner described above. This procedure may also be adopted in bilateral simple hyperæsthesia of a moderate grade.

When tinnitus aurium is associated with hyperæsthesia and reversal of the normal formula, you will often find that the tinnitus is diminished by the action of Ca D and increased by An Cl and An D. In this event, you must increase and prolong the action of Ca Cl and Ca D, avoid Ca O by gradual diminution of the current, and that of An Cl by gradual increase of the current. In other respects the treatment is the same as in simple hyperæsthesia.

The conditions become more difficult when other anomalies of the normal formula, with or without hyperæsthesia, are present. It must be left, then, in great part to the tact of the electro-therapeutist to determine what method will prove successful in the individual case. The leading principle should be, however, that the method of treatment depends upon the fact whether the tinnitus is diminished by An D or Ca D.

Under all circumstances, however, you should not be deterred by theoretical considerations from one or another method of treatment until all available methods have been exhausted. This will hold true also of all the rarer anomalies of reaction hitherto unmentioned, of the entirely irregular forms associated with tinnitus aurium, and also of those cases in which galvanic examination furnishes no distinct results. In these not infrequent cases you may try any method of electrical treatment, however hopeless it may seem, and test it systematically for some time. I have repeatedly seen considerable improvement effected in this manner. In such patients I should consider it justifiable to employ even the faradic current.

In the majority of cases these methods of treatment require great exactness of manipulation, reliable apparatus and suitable application, together with an accurate knowledge of all the data in question and a clear conception of the object to be effected. It is best to employ the external method of application (*vide* page 65), the indifferent electrode being placed in the opposite hand. Good fixation of the electrodes is necessary; the polarity changer and all other parts of the apparatus must be so arranged that unwished for interruptions of the current are prevented; special care should be paid to the gradual increase and diminution of the current. Diminution of the number of elements alternating with diminution of the resistance of the rheostat (in the auxiliary circuit), long-continued application of the lower strengths of the current before it is still further weakened,

and finally the passage of the aural electrode over the scalp are the methods by which the current can be gradually diminished.

The sittings must often be quite long—from five to twenty minutes; their repetition depends upon circumstances.

The results of the galvanic treatment of tinnitus aurium vary greatly, sometimes very brilliant and rapid, sometimes very gradual, often entirely absent. The proportion of successes to failures cannot be determined at the present time. In the most favorable forms (simple hyperæsthesia with a certain amount of diminution of the tinnitus by An D) the tinnitus usually disappears after the sitting, for one-quarter to one-half hour, or for several hours, perhaps until the next day. It rarely disappears permanently after a single sitting, though this has happened (*vide* Observation 157). As a rule, it returns gradually with increasing severity after the period mentioned, and is again made to disappear (this time for a longer period) by the next galvanic sitting. And thus recovery is gradually produced. The more rapidly the tinnitus returns after the first sitting, and the more it approaches its former intensity and character, the more slowly will recovery ensue, and vice versa. From the observations made hitherto, all forms of tinnitus appear to be curable which can be made to disappear completely by An D. In the less favorable cases a long time often elapses before a good result is secured, and not infrequently various methods of treatment must be employed in order to attain our ends. I have observed repeatedly that tinnitus aurium which was inaccessible to the current at first was improved and cured by galvanism after an intermission of half a year to a year in the treatment.

The previous observations show that *nervous deafness* is improved very often by the galvanic current and by the same manipulations which produce disappearance of tinnitus aurium (*vide* Observations 152, 155, 160). But cases of deafness also occur in which tinnitus aurium is not present and in which the nervous origin is rendered at least very probable by the absence of demonstrable affections of the ear, the presence of anomalous formulæ of galvanic reaction and of various nervous disturbances.

161. *Observation by Brenner. Deafness without demonstrable anatomical changes; anomalous galvanic reaction.*—A man, aged twenty-three. Suffering for two years from deafness; examination of ear negative. Watch heard at five inches on right side, three inches on left; conversation at three feet, whisper only in immediate neighborhood. Formula of galvanic reaction:

Ca Cl,	loud ringing.	
Ca D,	ringing lessened.	
Ca O,	} sensation of ringing of a different timbre.	
An Cl,		
An D,		
An O,	ringing lessened.	

The object of treatment was the avoidance of the pathological An Cl reaction by gradual increase of the current, the increase of An O reaction by prolonged duration of the current, the increase of Ca Cl reaction by change of polarity from An to Ca, and the avoidance of Ca O reaction by gradual diminution of the current.

After treatment for two months: watch at twelve inches on right side, seven inches on left; conversation at seven feet, whisper at two feet.

162. *Observation by Brenner. Deafness with anatomical changes; torpor of the acoustic nerve.*—A woman, aged fifty years. Suffering for seventeen years from increasing deafness with severe tinnitus aurium and mental depression produced thereby; watch cannot be heard at all; membranæ tympani slightly cloudy with normal light spot; hammer very prominent. Long-continued treatment relieved the tinnitus and improved hearing so that watch could be heard at forty-six inches on right side, two and a half inches on left side. Right auditory nerve presented an almost normal formula of galvanic reaction, the left one all the signs of torpid reaction (page 101). Left ear treated with galvanic current, with change of polarity from An to Ca. The result was:

First sitting: hearing at 2½ inches

Second sitting: hearing at 3½ inches

Sixth sitting: hearing at 6½ inches

Ninth sitting: hearing at 11 inches

Tenth sitting: hearing at 15 inches.

The signs of diminished excitability decreased, and Ca D and An O reactions made their appearance. Treatment discontinued.

A few words may be devoted to a consideration of Menière's disease, since its nervous origin is abundantly proven by the sudden deafness, the not infrequent tinnitus aurium associated with violent vertigo and vomiting, the absence of changes in the external and middle ear, and the results of examination of the auditory nerve itself. Whether the affection is due to a hemorrhage or inflammation of the labyrinth has not been decided positively.

This almost hopeless disease may be treated by the galvanic current, the method being based upon the formula of galvanic reaction which may be present or upon the rules which hold good generally with regard to the treatment of intracranial anatomical processes.

NEUROSES OF THE GUSTATORY NERVES

are very rarely the object of special electrical treatment. The only disturbance which comes into question occasionally is the paralysis of taste or ageusia. It is scarcely ever found isolated, but is very often a symptom of the most varied nervous diseases, as in lesions of the trigeminus at the base of the skull, lesions of the chorda tympani in the middle ear, in rheumatic and traumatic facial paralysis, in peripheral lesions of the lingualis, or in diseases of the glosso-pharyngeus; furthermore, in certain cerebral

affections, in hemianæsthesia (associated with an affection of the other special senses), with especial frequency in hysterical hemianæsthesia.

You are aware that all or the majority of these lesions may be treated with the electrical current. Above all, treatment should be directed to the primary affection, according to the well-known methods, which may vary greatly in individual cases (galvanization transversely and longitudinally through the skull, etc.).

The disturbance of taste ordinarily disappears rapidly, as, for example, in rheumatic facial paralysis, provided, of course, that the lesion is curable. As a rule it will be unnecessary to apply treatment directly against the ageusia, but the latter sometimes persists longer than the primary disease or remains permanently.

If direct treatment is considered advisable, the nerve of taste may be excited directly in the buccal cavity or the tongue (preferably with the galvanic current). The mucous membrane which is affected is stroked with a small sponge electrode (pharyngeal electrode, *vide* page 221) or with Neumann's pair of electrodes (consisting of olive-tipped sounds) for a couple of minutes with a strength of current sufficient to produce distinct gustatory sensations upon the normal half of the patient's tongue or upon your own tongue.

NEUROSES OF THE OLFACTORY NERVES

are much more infrequent and unimportant than gustatory neuroses, although they often produce a much more considerable disturbance of taste than the latter.

Diminution of the sense of smell, or anosmia, alone has been the subject of electro-therapeutic efforts. It is not very infrequently isolated (from diseases of the nose itself, lesions of the olfactory nerves from injuries to the skull, degeneration of the nerves from senile processes, etc.), but is often combined with various other nervous disorders, which are dependent upon the primary affection (in cerebral tumors, gunshot wounds through the orbit, meningitis, cerebral hemorrhage, hysteria, etc.). With regard to the localization of the therapeutic measures it may be stated that anosmia of the left side is often associated with right hemiplegia and aphasia; that anosmia associated with hemianæsthesia and implication of the other senses indicates the internal capsule as the site of the lesion; but that the site of cortical anosmia still remains to be definitely located (probably in the parietal lobes).

A few cases of successful electrical treatment of anosmia have been reported. Duchenne has seen good results from faradization of the nasal mucous membrane, especially in hysterical patients. In three cases of anosmia of one to ten years' standing (probably due to chronic coryza)

treated by Baerwinkel, recovery ensued in two cases after six sittings, and improvement in the third after six sittings. His method consisted of galvanization with a weak current from the neck to the nasal mucous membrane, the catheter-shaped electrode being moved slowly across the latter, especially the posterior parts; this produced various subjective olfactory sensations and profuse secretion. Fieber also derived benefit from the application of the galvanic current (olive-shaped electrodes in both nostrils). During the galvanic treatment of a case of tinnitus aurium, Neftel observed the restoration of the sense of smell which had been lost for twenty years. Beard also observed improvement of anosmia from external and internal galvanic treatment of the nose; and Ferrier cured within a few weeks a traumatic anosmia of long years' standing by the galvanic current (transversely through the zygomatic fossæ or from the root of the nose to one of these fossæ).

There is no doubt, therefore, that some cases of anosmia can be cured by means of electricity.

XI. DISEASES OF THE ORGANS OF LOCOMOTION, THE GLANDS, THE THORACIC VISCERA, AND THE DIGESTIVE APPARATUS.

LECTURE XXXIV.

Diseases of the Organs of Locomotion: Muscular Rheumatism; its Varieties and Character; Various Methods of Treatment; Results—Articular Affections; Introduction—Acute Inflammations of the Joints: Traumatic and Other Forms; Rheumatic Polyarthritis; Chronic Inflammations of the Joints: 1. Monoarticular Chronic Articular Rheumatism; 2. Polyarticular Chronic Articular Rheumatism; 3. Arthritis Deformans; 4. Stiffness and Ankylosis of the Joints—Diseases of the Glandular Organs; Tumors of the Lymphatic Glands—Scrofula—Splenic Tumors—Diseases of the Thoracic Viscera—Nervous Asthma—Nervous Palpitation of the Heart—Debility and Irregularity of the Heart.

In this section I shall discuss a series of diseases in which the electrical current occasionally produces very notable curative effects. They include various affections, partly nervous, partly non-nervous, to a certain extent of great practical importance and scientific and therapeutic interest, to some extent of subordinate significance, though always worthy of mention. I begin with

DISEASES OF THE ORGANS OF LOCOMOTION.

The active organs of locomotion, the muscles, have engaged our attention to such an extent that not much remains to be said in this connection.

I shall refer only to a very frequent and painful affection, which is generally known under the term muscular rheumatism, and in which electrical treatment is attended usually with very favorable results. The affection occurs in various forms and in all possible muscles of the body, and is known preferably as myalgia. Rheumatism of the lumbar muscles is known as lumbago, of the neck muscles as torticollis or caput obstipum, of the chest muscles as pectoral myalgia or pleurodynia, etc.

All these forms occur quite often, are attributed generally by the patients to cold or a sudden over-exertion and strain of the muscles; they

are, under all circumstances, very painful and often very obstinate, so that they sometimes resist all methods of treatment for months and years.

We are still entirely in the dark with regard to the nature of this affection. It is assumed that in a part of the cases slight circulatory disturbances occur (congestion, temporary inflammation with serous and similar exudations), or, in another part of the cases, local solutions of continuity occur in the bundles of muscular fibres; perhaps neuritic or neuralgic affections sometimes develop in the sensory fibres within the muscles, muscular sheaths or fasciæ; and finally some forms constitute a transition to tonic spasm of the muscles or cramp, and may be termed rheumatic contracture.

The first method of treatment is the application of the faradic brush to the integument over the painful muscles with a vigorous current for a few minutes, so that intense redness of the skin is produced; sometimes the pains disappear at once as if blown away.

Another method is vigorous faradization of the affected muscles themselves, with strong currents, so that powerful contractions are produced. In the lumbar muscles medium electrodes should be employed, both being placed upon the muscle; the current should be gradually increased and diminished several times during the sitting, which lasts from five to ten minutes. This procedure is quite annoying, because the contractions of the affected muscles are in themselves very painful; but the pains subside usually after a short period of contraction.

Galvanic applications are much milder and at least as effective, in some cases much more so than the preceding methods. This plan consists in the application of the An to the most painful point, while the Ca is placed opposite or upon an indifferent spot, or in succession upon several spots in a circle around the An. A stable current of considerable strength is employed for a few minutes; at the close of the sitting, a few interruptions and changes of polarity are made, so that vigorous contractions of the muscle ensue. This is usually followed forthwith by relief; the same procedure may be immediately repeated once or twice (duration of entire sitting five to fifteen minutes) until the pain has wholly disappeared.

Poore recommends the combination of a sort of gymnastics (vigorous contraction) of the affected muscles with this galvanic treatment.

The results of all these procedures are commonly very brilliant, and the relief of muscular rheumatism is one of the most grateful objects of electro-therapeutics. Considerable relief is experienced usually at once after treatment, not infrequently complete disappearance of the pain and stiffness. This is true not alone of recent cases, but I have seen it occur when the affection had persisted obstinately for months. I have even seen immediate relief produced by the galvanic treatment in several cases of acute febrile myalgia, but two to ten more sittings are requisite, as a rule, to produce this result.

Numerous attempts have been made to cure joint diseases by means of electricity, but the methods of treatment have not been systematically developed hitherto.

We have to deal chiefly with the various forms of articular inflammations and it appears serviceable to divide them into acute and chronic forms.

ACUTE INFLAMMATIONS OF THE JOINTS.

While some reject entirely the employment of electricity in acute inflammations of the joints, and a few regard it as useless or even injurious in all acute rheumatic inflammations, others believe that both the galvanic and the faradic currents are applicable and often very useful in the acute forms.

There appears to be no doubt that electricity is beneficial in acute traumatic inflammations of the joints, in subluxations and their sequelæ; Remak has obtained good results in these cases with the galvanic current, Weisflog with the faradic current.

The swelling, heat, and pain in the joints usually diminish rapidly after the sitting, their mobility increases and the regular continuance of treatment soon produces recovery. At the present time, however, this method has a formidable rival in skilfully performed massage.

Very favorable results have also been obtained in spontaneous rheumatic or symptomatic acute inflammations of the joints by Remak and Weisflog.

Remak's method, which may be recommended strongly, consists in the passage of a quite strong, stable galvanic current through the joint, with change of polarity but predominant influence of the An, especially while the pain is still very great; at the close of the sitting a few interruptions are made and labile currents are passed through the adjacent muscles and along the neighboring vessels and lymphatics. The duration of the sitting is ten to twenty minutes.

The method of faradic treatment practised by Weisflog, consists of the passage of a strong faradic current through the joint with large moist electrodes or by means of local electrical baths, several times daily for a shorter or longer period (fifteen minutes to one hour). Weisflog applies the current in this manner (the application being made by the patient) from six to ten times in the twenty-four hours, day and night, and reports very good results therefrom. This writer regards the faradic current as injurious in acute articular rheumatism. Remak is inclined to attribute a very favorable influence to the galvanic current in acute febrile rheumatism, both upon the local process as well as upon the fever and general dyscrasia so far as they are due to the local affection. He states that specially good results were obtained in the local disturbances, the pain, stiffness, muscular weakness, etc., left over after the cessation of the fever.

Not long ago Drosdoff reported some surprising observations concerning the action of the faradic current in acute articular rheumatism. He found that the sensitiveness to the faradic current (moist electrodes) was markedly diminished in the affected joints, and that faradization with a vigorous current for five to ten minutes reduced the increased temperature of the joint to the normal, markedly diminished the pains for a number of hours and, upon daily repetition, secured a more rapid and less distressing course of the disease. These results were verified completely by Beetz in Ziemssen's clinic, and he regards the faradic current as a valuable palliative, which may be combined serviceably with other remedies. Abramovski saw the same brilliant results from the application of the faradic brush to the integument over the joints (ten to fifteen minutes daily), but did not detect any analgesia, at least of the skin.

Since the employment of salicylic acid you will not be inclined to resort to the galvanic or faradic current in the treatment of acute articular rheumatism. But since individual cases occur in which the administration of salicylic or benzoic acid is useless, you may resort occasionally to the electrical current and, at all events, it is advisable as a tolerably certain palliative in combination with internal remedies.

CHRONIC INFLAMMATION OF THE JOINTS.

Among articular affections these constitute the real field for electricity; other methods of treatment are much more often useless, the disease continues for years and thus affords opportunity for the trial of the electrical current. Those forms are more accessible to treatment in which the tissues surrounding the joints are chiefly affected and in which deeper destructive changes of the cartilages and bones are absent.

1. *Monoarticular chronic articular rheumatism* is a quite frequent affection which may be located in any joint, most frequently in the shoulder and knee, then in the elbow and foot. It is associated not uncommonly with an abundant collection of fluid, or merely with thickening of the tissues, stiffness and great tenderness on movement, roughness and creaking in the joint, etc. It is combined very commonly with secondary, often considerable atrophy of the muscles, most marked in the deltoid and quadriceps femoris. It develops after injury, cold, gonorrhœa, and the like, is often spontaneous, frequently occurs upon a scrofulous basis (tumor albus); it is usually a very obstinate affection, and the ordinary surgical remedies (spirits iodine, massage, etc.) may prove useless.

This articular disease is one of the most favorable forms for electrical treatment. The following are the methods of treatment which may be adopted:

As it is desirable to secure the catalytic effects of galvanism, stable

currents should be passed transversely through the diseased joint in all directions; the effect will be increased by changing the direction of the current a number of times. In recent cases feeble currents and the predominant action of the An should be employed, in old cases stronger currents and vigorous action of the Ca. Exclusively labile applications to the adjacent muscles, blood-vessels, and lymphatics also appear to be very useful. The duration of the sitting varies from five to twenty minutes.

The faradic current may also be employed, the current being passed through the joint by means of moist electrodes or local baths; the current should be quite strong, the sitting ten to fifteen minutes. Weisflög makes several applications daily from one-half to one hour in duration.

The faradic brush may also be tried, especially when vigorous counter-irritation of the skin around the joint is desired or great tenderness is present.

The secondary muscular atrophy may be treated either by labile galvanic currents, Ca Cl and changes of polarity, by regular faradization of the muscles, or finally, by the feeble, continuous galvanic currents so strongly recommended by Le Fort and Valtat (*vide* page 120).

2. *Polyarticular chronic articular rheumatism* is often nothing more than a reduplicated variety of the affection just considered, or it develops sometimes as a sequela of a specific acute articular rheumatism. It is, under all circumstances, an annoying and obstinate affection, in which, however, electricity sometimes proves useful.

The treatment is carried out in the same manner as in the preceding form. Mixed treatment, like that employed by Erdmann (faradic brush, faradization and galvanization of the joints and muscles), may perhaps effect the desired object more rapidly.

3. *Arthritis deformans or rheumatismus nodosus* is one of the most severe forms belonging to this category, and usually resists the electrical current as obstinately as it does all other methods of treatment. Opinions differ with regard to the character of the disease. Probably several forms should be differentiated: one which appears mainly in the large joints and the spinal column in advanced life (*malum senile*), another which occurs chiefly in the small joints of the fingers and toes, giving rise to deformity and beginning in middle age (*arthritis pauperum*), and due mainly to rheumatic influences; and finally, probably another form, which must be regarded as tropho-neurotic in its origin.

The disease always lasts for years, sometimes throughout life, is characterized by the formation of nodules and deformities in the joints, violent pains, secondary muscular atrophy and general weakness.

The case treated by Cohen with faradism and cured within six months probably belongs in this category; Remak reports favorable results from galvanic applications (chiefly in the form of diplegic excitation); Moritz Meyer has also cured several cases by galvanization of the sympathetic;

Althaus obtained satisfactory results from galvanization of the spine and joints. The results obtained by Chéron are so brilliant that they are scarcely credible. I have treated an entire series of cases, but almost always without any success whatever.

In addition to local treatment of the joints, which should be carried out in the same manner as in the other forms of chronic rheumatism, we may recommend regular galvanization of the cervical sympathetic and the corresponding nerve plexuses, perhaps still more of the spinal cord itself. The relief of the general weakness and muscular atrophy, the improvement of the nutrition of the skin, and the frequent anomalies of the secretion of sweat, etc., are best effected by labile galvanization of the plexus, the principal nerve trunks, and the muscles of the extremities. In addition, trial of general faradization and the electrical bath is justifiable. The sittings should last from ten to fifteen minutes or more.

4. *Ankylosis, stiffness of the joints, periarthritic swellings, etc.*, which are observed not infrequently after traumata, gun-shot wounds, prolonged application of surgical bandages, etc., have also been the subject of successful electrical treatment. Moritz Meyer observed the disappearance of these affections after application of the galvanic current, mainly of the anode. It is immaterial whether one pole or the other is employed; it is probably better to use both alternately in order to secure the most intense catalytic action possible. But massage probably will be the most successful rival of electro-therapeutics in this field.

DISEASES OF GLANDULAR ORGANS.

Remak relates in his book on galvano-therapeutics (page 293) that he succeeded in relieving a row of swollen and painful cervical glands and in diminishing large goitres which had existed for a long time. Similar results have been obtained since by other observers.

Seeger, Chvostek, Onimus, Legros, and Picot have employed the galvanic current for the relief of tumors of the lymphatic glands, and regard the stabile and labile passage of a current through them and the adjacent lymphatics as the best method of treatment. It is better, probably, to apply both poles in succession, though perhaps the An may be applied for a longer period in one case, the Ca in another.

The faradic current has also been employed successfully in a few cases. Duchenne relieved enlargement of the cervical glands by means of faradism, and Moritz Meyer reports a case in which a cervical gland, as large as a hen's egg, was reduced by the faradic current to the size of a plum-pit in sixty sittings, and finally, the very remarkable observation of a tumor of stony hardness, situated between the head and the scapula, and larger than the head, which was reduced to a minimum by means of the

faradic current (two hundred and seventy-three sittings of one to one and a half hour each). Meyer has found recently that frequent interruptions of a very strong faradic current, passed through the glandular tumors for five to ten minutes, produce a separation of the swelling into several smaller glands, and thus markedly accelerate their absorption.

Chvostek has published a large series of observations concerning the galvanic treatment of goitre; in some cases he obtained remarkably rapid relief, frequently merely a partial diminution of the goitre, and in rare cases no results whatever. His plan consists in the daily passage of a stabile current for five to ten minutes.

Mention should be made also of the various attempts which have been made to diminish the size of an enlarged spleen by means of electrical currents. Chvostek has come to the conclusion that the electrical current may produce a distinct diminution of the spleen, demonstrable by percussion; this is effected in a reflex manner, the integument in the region of the spleen being vigorously faradized with two brushes for a period of about three minutes at each sitting. This author, who reports a number of striking results, and even in cases which did not yield to large doses of quinine, attributes them to reflex contraction of the smooth muscular fibres in the spleen, and even more to contraction of the blood-vessels themselves.

Botkin, who applies the faradic current to the enlarged spleen by means of moist electrodes, observed diminution of the size of the organ in leucæmia; Beyer obtained similar results, but faradization proved useless in the hands of Elias and Mosler. Skorczewsky found that faradization of the spleen (moist electrodes, strong current) produced a diminution in the size of the organ almost constantly (the enlargement was due to malaria).

Faradization of the spleen and vicinity may be recommended, therefore, in all obstinate cases of enlargement of this organ which resist other methods of treatment.

DISEASES OF THE THORACIC ORGANS.

The electrical treatment of pulmonary and cardiac affections has been tried hitherto in very few forms of disease and very little can be said concerning it.

Nervous asthma occupies the foremost position with regard to electrical treatment. On account of the uncertainty of our views concerning the real nature and site of asthma, no slight difficulties arise with regard to the choice of the location and the form of the application of electrical currents. We are still undecided whether we have to deal with a spasm of the bronchial muscles or of the diaphragm, with a vasomotor swelling

of the bronchial mucous membrane, with a disturbance in the domain of the pneumogastric or the sympathetic, with a direct excitation of these tracts or a reflex production of the asthmatic process, and finally at what point this direct or reflex irritation is situated.

We are therefore restricted to a purely empirical method of treatment. From the observations hitherto made, it follows that undoubted results can be attained in bronchial asthma by the use of electricity. Caspari cured a case, which had lasted a number of years, with the galvanic current, the Ca being placed upon the sacrum and the An slowly stroked along the spine from the neck to the lumbar vertebræ for ten to twenty minutes; recovery ensued after twenty-five sittings. Brenner observed considerable relief in a severe case of asthma from the application of the galvanic current to the pneumogastric (An in the neck, Ca between the larynx and the flexors of the head). Neftel systematically treated a series of cases with galvanism and states that he obtained surprising results. Starting from the assumption that asthma is due to an implication of the pneumogastric nerve, he made this nerve the special subject of treatment according to the polar method. It was found that in the majority of cases the application of the An, in others the Ca, to the pneumogastric had a brilliant effect; the Ca was specially effective in stopping the individual attacks. Neftel begins the application with a feeble current, and increases it with the aid of the rheostat until the attack is ameliorated, then gradually diminishes the strength of the current; duration of the sitting, two to ten minutes, at first daily, then less frequently. Schmitz also employed the galvanic current in a case of asthma and emphysema in which the attacks were always preceded by severe nasal and bronchial catarrh. The application of the electrodes on each side of the thyroid cartilage at the inner border of the sterno-mastoid produced immediate relief of respiration and copious expectoration. Schaeffer, on the other hand, obtained no benefit from galvanism, but secured brilliant results from the application of the faradic current. In accordance with his view that asthma is due very generally to an irritation of the nerves in the upper part of the respiratory tract (nose, pharynx, larynx, trachea), he applies both electrodes of a vigorous faradic current (for one-quarter to one-half hour) either immediately below the angle of the jaw or at the level of the thyroid cartilage. The applications are made in this manner, at first twice a day, later more infrequently and briefly. Schaeffer states that he has cured a number of cases in this way, and Bresgen also reports good results.

But numerous further observations are necessary before we can decide upon the value and the special indications of the individual plans of treatment.

The electrical treatment of *angina pectoris* has been discussed in Lecture XXVI., page 255.

It does not seem irrational to employ electricity in the treatment of

nervous palpitation of the heart. Flies alone appears to have employed this agent in a larger series of cases. In twenty-four cases of palpitation, five of which were associated with organic cardiac disease, he observed improvement in all, and in numerous instances (not associated with organic disease) complete recovery occurred after a few (five to six) sittings. His method consisted in the application of a moderately strong galvanic current to each vagus, for one to two minutes daily; the descending current is said to have had a better effect than the ascending. In the beginning the effect was merely subjective but soon became noticeable objectively by a diminution of the frequency and intensity of the action of the heart. I have also treated a case of severe palpitation and irregularity of the heart with intense cardiac asthma (probably due to organic disease), with the galvanic current (to the pneumogastric in the neck and the region of the heart), with relatively very favorable palliative results. I know of no other similar observations.

As a matter of course, it is entirely rational in such cases to appeal first to the inhibitory action of the pneumogastric and to stimulate this nerve with the current. Whether cases do not occur in which a depressing effect upon the cervical sympathetic or the excitomotor centres in the spinal cord (An stabile upon the cervical cord) will produce a similar effect can be determined alone by further experience.

In addition, trial may be made of the direct action of the galvanic current upon the intracardial nerves, according to Ziemssen's method, in order to regulate the action of the heart. This procedure consists in the passage of very strong currents from the spine to the cardiac region with very large electrodes, and with changes of polarity regularly performed at definite intervals. An increase in the frequency of the heart's action may be readily effected; diminution of the number of beats requires very considerable strength of current, at least in the normal heart. It goes without saying that great caution is necessary in such experiments.

In like manner it does not seem to be unjustifiable to make such experiments in *weakness and irregularity of the heart.* Ziemssen's method may be specially recommended in this connection, particularly the stabile passage of strong galvanic currents through the heart (also without changes of polarity), which produces an acceleration of the heart-beats in a regular rhythm (probably from direct stimulation of the ganglia of the heart) when applied at certain points (the auriculo-ventricular groove and its vicinity). Galvanization of the cervical cord, the pneumogastric and sympathetic may also be employed.

LECTURE XXXV.

Diseases of the Digestive Organs : Neuroses of the Œsophagus—Diseases of the Stomach : Nervous Vomiting ; Cardialgia ; Nervous Dyspepsia ; Methods of Electrical Treatment ; Atony and Dilatation of the Stomach—Diseases of the Intestines : Nervous Enteropathy ; Enteralgia ; Atony and Paralysis of the Muscular Coat of the Intestines : 1. Occlusion of the Intestines by Atonic Accumulation of Fæces ; Pathology ; Cases ; Methods of Electrical Treatment ; Invagination of the Intestines ; 2. Chronic Constipation from Atony of the Intestines ; Cases ; Percutaneous Faradization ; Recto-abdominal Faradization ; Galvano-faradization ; 3. Prolapsus Ani ; Paresis of the Sphincter Ani ; Ascites ; its Faradic Treatment.

DISEASES OF THE DIGESTIVE ORGANS

merit our attention, chiefly with regard to the digestive canal itself, while much less significance attaches to the larger and smaller glandular appendages.

Spasm and paralysis of the œsophagus alone are very rare pathological phenomena, but occasionally may become the subject of electrical treatment. This must be done according to general principles, preferably by the introduction of an electrode (an œsophageal bougie provided with a metallic tip) for a variable distance into the œsophagus, while the other electrode is placed upon the back of the neck, the dorsal vertebræ, or the sternum. Both currents are applicable, but it is advisable to be very cautious in the choice of the strength of current on account of the proximity of the pneumogastrics, since their excessive irritation might be attended with dangerous consequences.

Brenner rapidly cured a peculiar *sensory neurosis of the œsophagus*, a sort of nervous heartburn without other dyspeptic symptoms (vagus neurosis?), by the application of the galvanic current to the region of the pneumogastric nerve (An at the back of the neck, Ca between the larynx and sterno-mastoid, three minutes, with a few interruptions).

The investigations with regard to the electro-therapeutics of *diseases of the stomach* are more numerous and important.

The functional affections of this organ alone merit our attention. Various observers have obtained good results from the electrical current in *nervous vomiting*, as it occurs in hysteria, in pregnancy and child-bed, in migraine, dysmenorrhœa, etc. The methods adopted are more or less

empirical ; either faradization of the gastric region, from the spine to the epigastrium, or from the neck to the epigastrium, or both poles upon the region of the stomach, with tolerably strong currents ; or galvanization performed in the same manner ; or galvanization of the neck and the cervical cord. Improvement occurred in the majority of the cases reported."

The treatment of *nervous cardialgia* has been discussed in Lecture XXVI, page 256.

Special interest has been attached recently to so-called nervous dyspepsia, and the voices of some authors have been raised in favor of its electrical treatment. Opinions differ, however, with regard to what should be called "nervous dyspepsia." If, with Leube, we include only those cases in which digestion is normal with regard to duration and its chemical relations, but various disagreeable and annoying local or general symptoms occur during digestion (either as the result of abnormal irritability of the gastric nerves themselves or of the entire nervous system), the notion of nervous dyspepsia, in my opinion, would be too narrow. There can be no doubt that cases occur in which abnormal digestion may present the symptoms of nervous dyspepsia, due to deficient innervation of the glands of the stomach or to insufficient activity of its muscular coat. In one series of cases, therefore, the nervous dyspeptic disturbances occur during normal digestion, while in another series digestion itself is rendered abnormal by primary nervous disorders. But both forms are closely associated, and cannot be sharply separated in practice ; the electrical current is often a suitable remedy for both varieties, in addition to other measures which are indicated by the general condition of the stomach.

The diagnosis of these conditions is not always easy, but careful observation and examination and the exclusion of organic affections of the stomach will often permit their recognition with certainty.

In the electrical treatment both currents may be employed in various ways according to the predominant symptoms. Beard and Rockwell recommend general faradization and undoubtedly with justice, since the majority of these patients also suffer from general neurasthenia. They also recommend galvanization of the pneumogastric, sympathetic, and spinal column and later central galvanization. Leube employs in part strong faradic currents (from the back to the epigastrium), in part the galvanic current, almost always as an external application, the An in the epigastrium, the Ca upon the dorsal spine, with a tolerably strong current. Burkart saw admirable results from the application of the galvanic current in a similar manner ; he presses the An as deeply as possible into the region of the abdominal plexus, which is tender on pressure, and applies the Ca to the back with a stabile current. Stein prefers the faradic current and passes it transversely through the abdomen from one hypochondrium to the other with large flat electrodes, employing a current of moderate strength.

The faradic current should be employed first, especially if atony of the stomach and intestines is also noticeable; if abnormal sensations, hyperæsthesia of the gastric nerves and the like predominate, a trial of the galvanic current (anodal application) appears justifiable, particularly when the abdominal plexus is distinctly tender on pressure. Both currents may also be employed alternately. In addition, the methods generally adopted in neurasthenia may be tried, and in obstinate cases treatment of the pneumogastric and sympathetic in the neck and along the spine, perhaps also central galvanization and general faradization should not be omitted.

Atony and dilatation of the stomach are observed not infrequently in connection with nervous dyspepsia.

Atony of the stomach is a very common symptom in all possible diseases of the nervous system, especially in general nervous debility and in many central diseases. It may also occur as the result of chronic gastric affections, of continued and frequently repeated distention of the organ with an excessive amount of food and the like. After it has existed for a certain length of time, it gives rise, as a rule, to dilatation of the stomach and this may be attributed, in turn, to various pathogenic factors. Some cases are of traumatic origin from a blow or fall upon the epigastrium, especially in nervous, hysterical individuals; others result from gastric catarrh and atony of the muscular coat induced thereby; others arise from a relatively excessive strain upon the walls of the stomach by a large amount of food, and distention in consequence of development of gas or stagnation of the ingesta; the latter forms are especially frequent in stenosis of the pylorus.

In all these cases electricity may be employed for the purpose of stimulating the contractions of the stomach and relieving the atony which constitutes, under all circumstances, one of the chief conditions for the relief of the gastric dilatation. As a matter of course, the latter must also be treated by other remedies (especially the stomach-pump) and, above all, an attempt should be made to meet the causal indications. But even in such cases electricity should be employed as an auxiliary measure, and whenever we have to deal with purely nervous atony and ectasia of the stomach, electricity is undoubtedly the sovereign remedy.

The methods recommended by individual authors are not identical. Onimus advises the application of the galvanic current (from the epigastrium to the back, and from the lesser to the greater curvature), while almost all other authors employ the faradic current in preference. Fuerstner applies one electrode of a vigorous current to the left hypochondrium, the other to the region of the stomach, and moves the latter with strong pressure along the greater curvature toward the pylorus. Nefel applies both electrodes upon various diametrically opposite points of the surface of the dilated stomach, allowing increasing induction currents to pass ten to twenty times in succession.

It appears to me to be most serviceable to apply a large electrode to the back, immediately to the left of the spinous processes at the level of the cardiac end of the stomach, while the other somewhat smaller electrode is placed first upon the epigastrium and then successively upon the other parts of the entire surface of the gastric region; the current should be strong enough to produce vigorous contractions of the abdominal muscles. In galvanic applications, the An is placed upon the back, the Ca labile over the stomach, for three to eight minutes daily. It seems particularly useful to hold the sittings immediately after the stomach has been pumped out.

You will rarely find occasion for the internal application of an electrode by means of a suitable œsophageal sound.

The electro-therapeutics of *diseases of the intestines* also deals chiefly with functional nervous disturbances.

Nervous enteropathy, which occasionally forms a symptom of nervous dyspepsia and is manifested in a similar manner, except with regard to localization, is treated in the same way as the latter affection. As a matter of course the current will be applied more to the intestines and the hypogastric plexus of the sympathetic.

By far the most important object in these affections is the employment of electricity for the purpose of stimulating intestinal peristalsis, in all possible conditions, varying from atony to complete paralysis of the muscular coat of the intestines.

These frequent and annoying conditions constitute very grateful objects of electrical treatment, but they must be separated into two varieties:

1. *Occlusion of the intestines by atonic stasis of fœces.*—In this condition, after previous more or less obstinate constipation, complete obstruction occurs suddenly (from indigestion, distention of the stomach, intestinal catarrh or the like), with enormous accumulation of fœces, marked meteorism, severe pains, and not infrequently with very grave symptoms, which may be increased to ileus. It is naturally difficult to differentiate this form from other varieties of occlusion of the intestines (from invagination, internal strangulation, volvulus, etc.); the previous constipation, the demonstration of large masses of fœces, the prolonged absence of fever, perhaps previous similar conditions may render the diagnosis easier. Moreover, electrical excitation of the intestines in the other forms of occlusion would not produce any notable bad effects, and need be omitted only when peritonitis is distinctly developed. Indeed, Curci recommends electricity as a differential diagnostic measure in occlusion of the intestines from obscure causes; if improvement does not occur after one or two sittings we may assume a mechanical obstruction.

An entire series of observations have been reported in which, in these acute cases, after cathartic remedies and procedures had proven absolutely

useless and the symptoms had increased partly to a threatening extent, the energetic application of electrical currents was sufficient to excite intestinal peristalsis, and produce an evacuation of the bowels and recovery.

163. *Observation by Hofmann. Typhilitis stercoralis; paralysis of the muscular coat of the intestines; ileus.*—In a woman, aged seventy-two years. After protracted constipation, meteorism developed with foul eructations, and finally frequent vomiting with a fecal odor. Cathartics and enemata useless. Faradization of the intestines (one pole in the rectum, the other in the right iliac region) for a quarter of an hour with a strong current produced an evacuation from the bowels and recovery.

164. *Observation by Mario Giommi. Obstruction relieved by faradization.*—A farmer, aged fifty-one years. July 22d suffered from abdominal pain, followed by a few small stools and then by obstinate constipation. August 8th admitted to hospital; enormous meteorism, eructation of odorless gas, difficult breathing, dry tongue, etc.; resonant percussion note. Diagnosis of simple atony of the intestinal muscular coat and faradization recommended, after cathartics, etc., had proven useless. Faradic treatment, one electrode in the rectum, the other upon the abdomen over the transverse colon; vigorous current. First sitting of fifteen minutes; no result. Next morning, second sitting of twenty minutes; slight discharge of yellowish masses; at night after the third sitting, two copious evacuations; after the fourth sitting, further evacuations and then progressive improvement until recovery. Discharged September 2d.

165. *Observation by J. Simon. Intestinal obstruction; colic and ileus; rapid recovery under electricity.*—A man, aged forty-four years. Suddenly seized on June 15th with vomiting and colic; no fever. Obstinate constipation with increase of pain; gradual development of meteorism. Enemata and cathartics useless. No hernia or mechanical obstruction demonstrable. Increasing distention of the abdomen, anxiety, complete constipation, repeated vomiting; pulse frequent and thready. Symptoms continued to increase and electricity employed on night of June 17th. Faradization of abdomen and intestines, alternating with labile galvanic currents; twenty minutes. Vomiting ceased immediately and two fluid stools were passed. A second sitting at the end of three hours, followed during the night by twelve stools and copious discharge of gas. June 18th, continuance of the fluid evacuations; diminution of all the symptoms and undisturbed convalescence.

The majority of authors employ the faradic current in this condition, but Wharton has also applied galvanism successfully. He introduced one pole into the rectum, placed the other over the cæcal region, and passed a current of 14 elements with frequent interruptions for ten minutes. In the faradic treatment one pole is also introduced into the rectum and the other (Ca) stroked over the entire abdomen, with a very powerful current, so that vigorous contractions of the abdominal muscles ensue. The duration of the sitting is five to twenty minutes. Ballouhey describes a mixed method; at first, percutaneous labile application of the galvanic current to the abdomen, the An as near as possible to the point of occlusion; then abdomino-rectal faradization in the ordinary manner, and in

conclusion a similar method of galvanization (Ca in the rectum) with frequent interruptions ; several repetitions of the entire procedure during each sitting.

The sittings may be repeated two or three times a day until relief occurs. This is shown by the discharge of gas and of more or less copious, often enormous evacuations from the bowels, which occur not infrequently immediately after faradization, but usually after the lapse of an hour or more.

I will mention also that Bucquoy has successfully treated *invagination of the intestines*, as it occurs commonly in children, with the faradic current ; he advises its employment before any inflammatory complication has arisen. Two or three sittings of ten minutes' duration are said to be sufficient, as a rule, to produce an evacuation and relieve the invagination. As a matter of course, other methods of treatment should not be neglected.

2. *Chronic constipation from atony of the intestines* is an extremely frequent condition. It is observed very generally in all possible nervous affections, in hysteria and hypochondriasis, particularly in neurasthenia with or without nervous dyspepsia ; also in almost all chronic spinal affections (myelitis, ataxia, etc.), and in certain cerebral diseases, epilepsy, etc. ; it is especially frequent in women on account of improper habits of life, deficient exercise, etc., and not rare in young girls at the period of puberty ; also as a result of chronic intestinal catarrh, hemorrhoids, chronic peritonitis ; and finally, an important cause of this condition is the wide-spread misuse of purgatives, especially of the stronger drastic remedies.

Electricity is an admirable agent in this condition, and my large experience corroborates entirely the favorable reports furnished by Benedikt, Scarpari, Guenther, and others.

166. *Personal observation. Epilepsy ; severe constipation.*—A student, aged twenty years. Suffering from epilepsy and from so severe constipation that he had not had a passage for years, except after administration of active purgatives. After regular faradization of intestines for several weeks, evacuations occurred without medicine for several years.

167. *Personal observation. Nervous headache ; habitual constipation.*—A girl, aged nineteen years. Suffering from violent nervous headaches and habitual constipation ; was relieved of the latter symptom, in great part, by regular faradization of the intestines. At all events, the faradic current proved much more effective than all other purgative remedies.

168. *Personal observation. Gunshot wound of abdomen and spine ; obstinate constipation.*—An officer, aged twenty-six years. August 30, 1870, received a gunshot wound in abdomen, entering the right hypochondrium anteriorly, emerging on left side of fourth lumbar vertebra, followed by complete paraplegia with paralysis of sphincters ; gradual improvement during the winter ; the left limb regained power, the right leg remained completely paralyzed ; neuralgic pains, insomnia, retention of urine. Patient had not had a single spontaneous evacuation during this entire

period, except when diarrhoea existed from some cause; castor-oil or enemata employed regularly.

June, 1877.—Galvanic treatment of paralysis begun; castor-oil gradually lost its effect.

July 5th.—Constipation; then percutaneous faradization of the intestines, followed during the night by a profuse evacuation without the use of purgatives.

July 7th.—Scanty stool; second faradization.

July 8th.—Normal stool; faradization.

July 9th.—Stool in the morning; faradization in the afternoon, followed by copious evacuation shortly afterward.

July 10th.—Faradization in afternoon, followed by stool.

July 11th.—Stool in the morning; faradization; copious evacuation at night.

July 23d.—Patient left for Wildbad; reports, upon his return, that the evacuations from the bowels were much better, and that purgatives were rarely required, although large doses of morphine were administered regularly.

169. *Personal observation. Obstinate constipation in consequence of peritonitis.*—A man, aged twenty-three years. During last winter had severe perityphlitis with pericystitis, etc.; since then has suffered constantly from constipation. No spontaneous evacuations, except when diarrhoea was present.

July 9th.—Began percutaneous faradization of the intestines, and cathartic pills were discontinued. From the very first day, spontaneous passages occurred regularly, with few exceptions, either in the afternoon, soon after faradization, or upon the following morning. Treatment was continued until August 23d; injections were required occasionally. The improvement continued many months, and, at a later period, was rendered permanent by repetition of similar treatment.

170. *Observation by Stein. Habitual constipation.*—A girl, aged eighteen years. Began to menstruate four years ago, and since then has suffered from obstinate constipation, so that not a single evacuation has occurred without administration of purgatives. Anorexia and mental depression. A moderately strong faradic current was passed, for ten minutes, transversely through the abdomen. In the beginning, spontaneous evacuations occurred at intervals of two or three days, and after the nineteenth sitting, every day. Recovery was complete after twenty-eight sittings; since then the patient has had a good appetite, blooming appearance, cheerful disposition.

The electro-therapeutic methods in habitual constipation permit a gradual intensification according to the severity and obstinacy of the case.

As a rule, I begin with the percutaneous application of the faradic current. The An ("large" electrode) is placed upon the upper lumbar vertebræ, the Ca ("medium" electrode) is slowly passed over the entire surface of the abdomen; in the region of the cæcum the electrode is pressed in more deeply and allowed to remain stable for some time, then passed along the colon to the left iliac region, where it is also pressed in more deeply, then in a circle around the umbilicus and over the entire abdomen. The current should be so strong that vigorous contractions of

the abdominal muscles can be produced. But it seems serviceable to avoid these contractions, since they interfere with the passage of the current more deeply; it is therefore better to apply the electrode at a distance from the motor points. The duration of the entire sitting should be from three to ten minutes. In addition, I sometimes pass a current of varying direction, transversely from one hypochondrium to the other, the electrodes being pressed as deeply as possible into the loins.

To secure more vigorous action I then introduce an electrode into the rectum, the other being applied to the abdomen in the manner described above. An olive-shaped, metallic electrode, which is insulated to the tip, is introduced six to eight centimetres or more into the rectum; this gives rise to no sensation, or, at the most, to a slight feeling of pricking and burning, if the Ca is introduced. It is advisable to change the direction of the current several times, in order to allow the Ca, which is the more vigorous excitant, to act occasionally upon the rectum. The active contractions of the abdominal muscles should be the measure of the strength of the current; the duration of the sitting varies from three to ten minutes. (If the galvanic current is employed, prolonged closure of the circuit should be avoided, in order to prevent the formation of eschars; repeated changes of polarity should be made with a very short period of closure of the circuit.)

If this method proves insufficient, I precede it by an application of the galvanic current directly to the abdomen (An on the back, Ca stabile and labile and repeated closures, perhaps also changes of polarity), and also to the region of the splanchnic nerves in the dorsal sympathetic (An in the small of the back, Ca stabile and labile on both sides of the spinous processes of the fifth to the twelfth dorsal vertebrae); this application need not last more than a few minutes.

These various methods of treatment, as a rule, are followed very soon by an improvement of the atony of the intestines and the constipation. The purgatives, which are still required at the onset, become more effective, their dose may soon be diminished, then a spontaneous evacuation occurs occasionally, and the purgatives may be dispensed with gradually or reduced to a minimum; finally, complete recovery may ensue. This is usually followed by a very favorable effect upon the disposition and general condition of the patient. It is hardly necessary to state that certain forms of habitual constipation resist all electrical treatment.

Prolapsus ani and paresis of the sphincter ani may be mentioned as the last form of disease belonging to this category. These conditions occur in little children as the result of constipation and weakness, in adults, from hemorrhoids and obstinate constipation, from violent straining at stool, and not infrequently from spinal and peripheral paralyses. Good results have been obtained with the electrical current in these affections, especially in those forms due to atony of the sphincter, while the prognosis of paral-

ysis of the sphincter from diseases of the spinal cord naturally depends, in the main, upon the primary affection.

The chief indication in treatment is faradization of the rectum by the aid of the rectal electrode. In addition the intestines and sphincter ani may be stimulated by means of the galvanic current (changes of polarity), either with the rectal electrode or percutaneously from the sacrum to the perineum ; and finally the nerves of the sacral plexus may be stimulated in the ordinary manner.

In conclusion, I will mention that ascites has been repeatedly made the subject of electro-therapeutic measures, and not without success. In all cases the method consisted of vigorous faradization of the abdominal walls for ten to fifteen minutes.

Glax and Sigrist laid special stress upon the frequently repeated stimulation of the individual motor points of the abdominal muscles. The results were surprising in the majority of cases. The excretion of urine increases, the ascites diminishes and may disappear entirely in a short time. As a matter of course, however, the duration of recovery depends upon the primary disease.

XII. DISEASES OF THE URINARY AND SEXUAL ORGANS.

LECTURE XXXVI.

Diseases of the Bladder. Introduction. Vesical Spasm; Causal and Direct Treatment—Paralysis of the Bladder: Various Forms; Pathogenesis; Causal and Direct Treatment; Percutaneous and Internal Applications; Galvanization of the Lumbar Cord—Nocturnal Enuresis: Its Nature; Methods of Treatment—Diseases of the Male Sexual Organs: Inflammation and Hypertrophy of the Prostate; Orchitis—Functional Disorders: Impotence; Pollutions; Sperma.orrhœa; Aspermatism; Pathogenesis; Causal and Direct Treatment—Diseases of the Female Sexual Organs—Introduction—Ovarian Hyperæsthesia—Disturbances of Menstruation: Amenorrhœa; Dysmenorrhœa; Menorrhagia—Chronic Metritis—Changes in the Position of the Uterus—Deficient Secretion of Milk—Concluding Remarks—Contra-indications to the Employment of Electricity—Condition of the Circulatory Organs and Mode of Reaction of the Nervous System.

IN conclusion, we will enter upon a wide and varied field, viz.: disturbances of the urinary and sexual organs. These are extremely frequent in a great number of diseases (not merely those of a nervous origin), and not uncommonly are of great importance with regard to the course of the disease as well as of the general vital conditions of the individual. The most important organ in this connection is the bladder. Disturbances of the functions of this viscus are very common, partly as sequelæ and symptoms of nervous diseases, both of peripheral affections (in the cauda equina or the pelvic plexus, the vesical nerves, etc.) and particularly of spinal, more rarely of cerebral diseases; in part they occur isolated, as the result of cold, abnormal distention, or inflammation of the organ, partly as the result of reflex irritation or toxic agents which irritate the vesical mucous membrane, or act by paralyzing or stimulating the muscular coat of the organ. The circumstances under which vesical disturbances occur may accordingly vary greatly; sometimes they are isolated, more frequently they are part symptoms of a complicated clinical history, not infrequently they precede for a long time, as an isolated initial phenomenon, the symptoms of a central affection (locomotor ataxia, myelitis, and the like).

Electrical treatment may come into question in almost all these forms of disease, especially in those which are not associated with gross inflam-

matory or neoplastic affections of the bladder, and which are not due to mechanical injury from lesions of the adjacent organs (prostate, rectum, uterus, ovaries, etc.).

This is less true of so-called *spasm of the bladder, or tenesmus vesicæ*, which may occur in the form of a spasm of the detrusor (spasmodic incontinence), or as a spasm of the sphincter (spasmodic retention of urine, spastic ischuria). We then endeavor to attain our object, as a rule, by other means, especially if we have to deal with an inflammatory affection of the bladder itself. But there are also purely nervous forms of vesical spasm which may fall entirely in the domain of electro-therapeutics. We must first look, therefore, for the cause of the abnormal irritation and remove this. In this connection a disease within the spinal canal and in the cord itself must be thought of and, if present, treated in the proper manner. This may be done by stable galvanic currents through the lumbar cord and the lower part of the spine or by the stable application of the An upon the supposed site of disease; or, by means of vigorous stimulation of the skin, a counter-irritation may be produced which will remove the spasm-producing irritant, as in the treatment of neuralgia; the latter object is effected by the application of the faradic brush to the integument over the symphysis, perineum, sacrum, etc.

Direct treatment of vesical spasm depends upon the same principles as the treatment of spasm in general, viz., stable application of the galvanic current (gradually increased and diminished), with predominant action of the An upon the site of the morbid irritation—a requirement which is not readily fulfilled in treating the bladder. It is best to press one electrode deeply above the symphysis, the other (An) directly opposite upon the sacrum or upon the perineum. The same points of application should also be chosen in the employment of the faradic current.

I do not think that the urethral or rectal electrode is indicated in vesical spasm, as the condition of irritation is readily increased by their use, and there is danger of the formation of eschars from application of the galvanic current in this manner.

But the true field of electro-therapeutics in vesical affections is *weakness and paralysis of the bladder*. This frequent and important symptom may vary from the slightest indication to the most severe form; at times it is relieved rapidly, at times it is incurable and leads to the gravest dangers. It plays a particularly important part in spinal affections (ataxia, compression, hemorrhage, myelitis, sclerosis, etc.); also in the most varied peripheral nerve lesions, which affect the vesical nerves within the cauda equina or in the sacral plexus or its branches. This symptom is much rarer in cerebral diseases, so much the more common in hysteria. Finally, paralysis of the bladder may occur isolated, with or without a demonstrable cause (cold, injury, concussion, distention, opium poisoning, etc.).

Paralysis of the bladder may occur in various ways; if it affects chiefly

the detrusor, the phenomena of retention of urine are presented; if it affects mainly the sphincter, incontinence of urine is produced. Not infrequently both parts of the muscular structure of the organ are paralyzed at the same time—the patients cannot retain the urine, nor can they discharge it voluntarily. In such an event, either an occasional complete and regular, but involuntary evacuation of the bladder occurs (if the reflex apparatus in the lumbar cord is unimpaired), or there is a constant dribbling, though the bladder may be dilated at the same time by the excessive stasis of urine. It would lead us too far to enter into all the details concerning the innervation of the bladder and the various possibilities of its disturbance in different parts (in the muscular coat, the peripheral nerves, the lumbar cord with its centres of micturition; or, above them, in the sensory and motor tracts for the innervation of the organ, which pass to the brain).

But it is indispensable to rational electrical treatment that an attempt be made to ascertain in each individual case the character and localization of the disturbance, the manner in which it was produced, and particularly the exact site of the paralyzing affection in the nervous system.

Upon these features depends the method of electrical treatment. Your attention should be directed first to the primary disease and its appropriate electrical treatment instituted. I need add nothing here to my previous remarks concerning the treatment of diseases of the spinal cord, peripheral nerve affections, hysteria, etc. Nor do I wish you to believe that I regard electrical treatment as the sole remedy for these primary diseases; on the contrary, I know that much is effected by other measures, indeed often more than by electro-therapeutics.

In addition to this causal treatment and in the not infrequent cases in which this is impracticable, direct treatment of the vesical paralysis must also be employed. It may be effected in various ways—percutaneously, with moist electrodes, or internally, by means of a catheter, with the faradic or galvanic current.

In the percutaneous method, one pole (as a rule, the An) is applied to the region of the lumbar enlargement upon the lower dorsal and upper lumbar vertebræ, the other (Ca) upon the region of the bladder. If retention is most prominent, the electrode is pressed in as deeply as possible immediately above the symphysis; if incontinence constitutes the main feature, it is applied to the perineum as close as possible to the sphincter. If both parts of the muscular structure are affected, either both applications may be made, or one pole is placed above the symphysis and the other upon the perineum. The galvanic current may be applied, stabile and labile, for a few minutes to these situations, and several interruptions and changes of polarity made. The current should be of such a strength that Ca Cl produces vigorous contractions of the abdominal muscles when applied to their motor points.

In the internal method, the An is applied in a similar manner to the lumbar region; a catheter-shaped electrode, insulated as far as its metallic tip, is introduced into the urethra—as far as the neck of the bladder in incontinence, in order to stimulate the sphincter directly, and into the bladder itself (either full of urine or injected with lukewarm salt water) in case of retention. As a matter of course, care must be taken to disinfect the catheter-electrode. With the galvanic current, brief Ca closures or a few changes of polarity with a very short period of closure may alone be made in order to avoid eschars; it is best to regulate the strength of the current with the galvanometer. The faradic current may be quite strong, as the bladder is not at all sensitive, and the urethra very slightly so in its deeper parts. The strength of the faradic current may be measured also by the fact that, upon faradization of the sphincter, the latter contracts at each closure of the current, and thus moves the catheter somewhat anteriorly out of the urethra. In faradization of the detrusor, it is serviceable to direct the current to all parts of the walls of the bladder, the An being placed upon the abdomen to the right and left, and above the bladder, and also on the perineum; the muscular contractions produced furnish a satisfactory measure of the strength of the current. In internal applications the sitting should not be very prolonged.

Finally, an application may be made within the rectum; the An (an olive-shaped metallic electrode) is introduced into the rectum to the proper height, the Ca applied above the symphysis, and the galvanic or faradic current passed in the same manner as described above.

In all obstinate cases of paralysis of the bladder I add usually a direct and vigorous galvanization of the lumbar cord, in order to stimulate directly the centres for the innervation of the organ. According to circumstances, I associate with this a vigorous labile cathodal application from the cauda equina to the coccyx and perineum, or an application to the entire spinal cord as high as the cervical vertebræ.

The results of treatment vary greatly in individual cases: they are usually very slight in transverse myelitis, compression, hemorrhage, etc., very much better in ataxia, in which electrical treatment often secures excellent palliative effects; very favorable, even brilliant, in hysterical forms and also in cerebral paralysis of the bladder, and likewise in certain toxic forms or in paralysis from unknown causes.

Nocturnal enuresis is a special form of weakness of the bladder, which constitutes an extremely grateful object of electro-therapeutics. This condition seems to me to be due, in the large majority of cases, to the disproportion existing between the profoundness of the sleep and the strength of the sensory irritation occasioned by the full bladder. At all events this holds true of all cases in which no disorder of micturition occurs during the day. But it is not always easy to determine what part should be attributed, in the individual case, to the abnormally deep sleep,

and what to the diminished sensory irritability of the bladder and the neck of the organ. Cases undoubtedly occur in which the mere profoundness of the sleep is the cause of the annoying affection; in others there appears to be a dulness of the sensory excitability of the bladder. But it may also be attributed, perhaps, to an increased excitability of the vesical centres in the lumbar cord, which leads to an uncontrollable reflex evacuation of the bladder upon a slighter peripheral stimulus than normal. Finally, a certain weakness of the sphincter vesicæ must be assumed in those cases in which more or less marked incontinence is present during the day. The site of the disturbance, accordingly, may be sought for in various localities—peripherally, in the lumbar cord, higher up in the spinal cord, perhaps even in the brain. As all other evidences of a gross lesion are absent, we must assume a functional disturbance of these tracts, probably dependent in many cases upon a neuropathic disposition.

The treatment must be directed mainly to the bladder, preferably according to Seeligmueller's method. He introduces a metallic wire about one centimetre long into the entrance of the urethra, connects it with the Ca of the secondary faradic current and applies the An as the sponge electrode over the symphysis; a current which can be felt distinctly should be passed for several minutes. The results are illustrated by the following case:

171. *Observation by Seeligmueller. Nocturnal (and diurnal) enuresis.*—A woman, aged twenty-two years. Suffered since earliest childhood from incontinence of urine by day and night; all possible measures proved useless. Occasional remissions, varying from one to several months in duration, during which the nocturnal enuresis disappeared but the patient was extremely inconvenienced by the affection during the day. During the last six months, the patient was awakened regularly two or three times during the night, and notwithstanding this precaution enuresis sometimes occurred. Very serious effects of the disorder upon the general condition, preventing the enjoyment of life, producing emaciation, hectic appearance, depressed mental condition. The faradic treatment, described above, instituted for five minutes; immediate improvement after first sitting; only urinated twice during the day, not at all at night. Normal condition after the third sitting. After eighth sitting, patient discharged cured; recovery permanent; general condition excellent.

I apply usually the An to the lumbar cord, the Ca at first above the symphysis, then upon the perineum, with a tolerably strong current for one to two minutes; at the close, a wire electrode is introduced about two centimetres into the urethra—in girls I apply a "small" sponge electrode between the labia close to the meatus urethræ—and the faradic current passed for one to two minutes with such a strength that a distinct, somewhat painful sensation is produced.

In more obstinate cases I pass the urethral electrode as far as the neck of the bladder, or, in addition, I employ the electrical current in the man-

ner described above ; at all events, galvanic applications always are made to the lumbar cord, and perhaps to the entire cord as far as the cervical spine.

The results of electrical treatment are usually excellent, especially in older children or in adults ; improvement occurs after one or more sittings, recovery, as a rule, in a short period. However, protracted treatment is necessary sometimes, and I will not conceal the fact that electrical applications may prove entirely useless.

Among the *diseases of the male sexual organs*, the functional disturbances are particularly adapted to electrical treatment.

The statements made by Chéron and Moreau-Wolf concerning their results from the galvanic treatment of *inflammation, swelling and hypertrophy of the prostate* are not very credible, and have not been substantiated by others. These authors introduced a metallic electrode into the rectum, pressed it against the prostate (usually the Ca, the An only when marked tenderness was present) and applied the other electrode to the perineum. Currents of moderate strength, of five to ten minutes' duration ; eighteen to twenty sittings altogether. The results were described as remarkably favorable, and the procedure as much more effective than other surgical and medical measures.

These authors state also that similar results were achieved in *blenorrhoic and traumatic orchitis*. The method consists of the stable passage of a strong galvanic current through the enlarged organ (for six to eight minutes) ; then a stable current from the most painful part of the swelling to the seminal duct (four to six minutes), and finally an ascending current along the seminal duct. This application is said to be followed forthwith by relief and recovery, and the latter is complete after a few sittings. These statements also require confirmation. I have mentioned them in order to attract the attention of those who employ electricity in this branch of medicine.

Atrophy and flaccidity of the testicles which accompany many functional disorders and are due usually to onanism and sexual excesses, have also been treated by electricity and not without success. The method consists of the passage of moderately strong faradic or galvanic currents through the testicles for a few minutes, perhaps also galvanization of the seminal duct.

The most important field for the electro-therapeutist is afforded by the frequent functional anomalies, which are manifested by various grades of impotence, pollutions, spermatorrhœa, and aspermatism. I cannot enter in detail into the pathology of these affections, but will mention that they are due in part to gross anatomical changes, to the sequelæ of inflammations of the urethra, testicle, and epididymis, seminal duct, prostate gland, perhaps to new growths, etc. As a rule very little can be effected by electricity in such cases.

Another part of the cases must be attributed to serious organic diseases of the peripheral or central nervous system ; here the disturbances of the sexual function, pollutions, impotence, spermatorrhœa, priapism, are merely the symptoms of a beginning locomotor ataxia, chronic myelitis, or compression of the spinal cord, or perhaps of a severe lesion of the nerves of the cauda equina, etc. It is well known that some diseases of the spinal cord often diminish or abolish the sexual function at an early period (especially in ataxia, transverse myelitis, compression, chronic meningitis), while it remains entirely intact in others (in the forms of poliomyelitis, spastic spinal paralysis, etc.). In the former, electrical treatment may be employed occasionally in order to act directly upon the disordered sexual function as a symptomatic remedy, or to relieve the debility which may have persisted after the recovery of the primary affection. However, the possibility of recovery or improvement always depends mainly upon the primary disease, and, as Benedikt has rightly remarked, it is not always a benefit to the patient to have this function restored at an early period, for an ataxic patient may suffer much injury from irritation of the spinal cord due to sexual intercourse.

A third group includes those cases of disordered sexual function in which these are either isolated, due to local morbid influences, ordinarily to functional over-stimulation, and thus form the chief object of complaint ; or they occur merely as a symptom of a general functional neurosis, neurasthenia, spinal irritation, hypochondriasis, or the like, or they develop upon the basis of a neuropathic disposition, of a general nervous weakness and irritability, perhaps upon the addition of other very slight injuries (sexual excesses, inflammation, and conditions of irritation or flaccidity in the urethra or region of the ejaculatory ducts). These are by far the most frequent forms and those in which electrical treatment is specially indicated. They constitute generally the various stages of "irritable weakness" of the sexual function and lead to diminished potency, premature ejaculations, imperfect erection, abnormally frequent nocturnal pollutions, finally to daily pollutions and spermatorrhœa. These conditions are accompanied, as a rule, by a host of other nervous symptoms, by manifestations of neurasthenia and particularly by marked hypochondriacal depression.

In addition, cases occur which do not belong to any of these groups, in which, for example, absolute impotence or abnormal pollutions or aspermatism are observed in otherwise healthy men, with a pure previous history and without any signs of disease of the genitals or nervous system ; and finally certain of these disorders may be due to diabetes, lead poisoning, alcoholism, and the like.

All these manifold conditions have been treated more or less successfully by various observers with electricity.

The method of treatment depends, as a matter of course, upon the

primary disease, and in many cases this is the essential feature. I refer you accordingly to my previous remarks upon the treatment of diseases of the brain and spinal cord, still more of neurasthenia and allied conditions.

As a rule, however, the majority of cases also require direct electrical treatment of the genitals, and this may constitute the main feature of treatment if the sexual disorder is the sole or predominant symptom.

In the large majority of cases we must stimulate and invigorate the nervous functions, relieve parietic conditions of the lumbar cord and the genital nerves; in much rarer instances, conditions of abnormal irritation must be relieved.

As a general thing the galvanic current is preferable. The following is the method which I consider most serviceable: the An ("large" electrode) is placed upon the lumbar cord, the Ca ("medium" electrode) stable and labile along the seminal canal from the inguinal ring downward, for one to two minutes on each side; the current should be tolerably strong, so that a distinct burning sensation is produced in the integument. Then follows vigorous labile application of the Ca (about a minute) to the upper and lower surfaces of the penis as far as the glans; finally the Ca may be applied labile and stabile upon the perineum as far forward as the root of the penis (one to two minutes); a few interruptions or changes of polarity may be made in order to secure more active stimulation. If the penis, especially the glans, is anæsthetic, the Ca may be applied in this position for a longer period. If the testicles are atrophic, flaccid, and the scrotum cool, the current may be passed directly through them.

This method of application is suitable especially in impotence; if polutions or spermatorrhœa are present, the irritant procedures should be avoided, and stabile currents should be employed in great part, perhaps also the An upon the perineum. If there is reason to believe that the spermatorrhœa is produced or maintained by conditions of irritation or flaccidity in the region of the ejaculatory ducts, these parts should be treated directly by means of the urethral electrode; this is introduced as far as the prostatic portion, the An being employed in conditions of irritation, the Ca in conditions of flaccidity; the current should be moderately strong, but of very short duration.

The faradic treatment of impotence and spermatorrhœa is not excluded by any means; the electrodes may be applied in the same manner as in galvanic applications, and moderate currents should be employed. Faradization of the testicles has been recommended also in poor nutrition and slight turgescence of these organs; Guenther states that he has employed it successfully in azoospermia. In anæsthesia of the integument or striking coldness of the penis, flaccidity of the scrotum, etc., the faradic brush may be applied to the genitals to advantage (also to the perineum and the anal region, from which vigorous reflex contractions of the scrotum

may be secured). Moebius suggests the application of an electrode within the rectum, in order to come in closer proximity to the ejaculatory ducts and the prostate gland; the other electrode is applied to the perineum, and the faradic current passed for two or three minutes; in conclusion, a short galvanic application is made, the Ca in the rectum, the An upon the sacrum.

In severe or obstinate cases I never omit regular galvanic treatment of the lumbar portion of the spinal cord, which contains the most important centres of the genital function. In cases of supposed anatomical lesions, I add the galvanic treatment of the cauda equina, the applications being extended generally to the cervical cord, especially in patients in whom we suspect a general weakness of the entire genital nervous system.

The treatment must be continued for a long time, at least six to eight weeks (daily sittings), and often much longer. It may be combined profitably with other measures of treatment.

The results which I obtained by these methods were often very satisfactory, particularly in the purely functional forms. But I have met also with cases which presented apparently a good prognosis, yet resisted electrical treatment entirely. It is well, therefore, not to promise too much—apart from those cases in which we have to deal with a sort of psychical impotence.

Many individual observations and a few more extensive works have been published concerning the electrical treatment of *diseases of the female sexual organs*. I have had no personal experience in this field, and must confine myself, therefore, to a brief reference to the most important observations which have been published.

An entire series of observations have been made upon the electrical treatment of disturbed menstruation (Rockwell, Baker, Althaus, Taylor, Fieber, Good, Dixon Mann).

The electrical current often produces very striking beneficial effects in *amenorrhœa*, whether it persists for a long time at the period of puberty, or has developed at a later period from other causes. It has been often observed accidentally by electro-therapeutists, that during electrical treatment, especially galvanization of the back and legs or general faradization, the menses became more profuse or appeared prematurely.

The direct electrical treatment of *amenorrhœa* may be carried out in the following ways:

With the faradic current, the application of the brush to the soles of the feet or the inner surfaces of the thighs, or the passage of the current from the neck to the uterus. In addition to galvanic treatment, Dixon Mann also employs direct faradization from the loins to the cervix uteri at the time of the expected menstruation.

The majority of observers, however, have preferred the galvanic current. The following methods may be adopted: galvanization of the cervical sympathetic (Fieber, Good); in addition, galvanization of the spine, especially its lowermost parts (Clemens, Good); also galvanization from the lumbar region (An) to the ovaries (Good, Althaus), and finally intra-uterine galvanization (Dixon Mann, Althaus), either by the introduction of the Ca into the uterus, the An being applied to the lumbar cord or the ovaries, or by the application of the An to the os uteri and the Ca upon both ovaries in succession. The uterine electrode may be a catheter-shaped instrument or a small sponge electrode or a small flat cervix electrode. The current should be moderately strong, two to three sittings a week, each ten to fifteen minutes in duration. The results are said to be often surprising.

I have mentioned previously that electrical currents may prove successful in dysmenorrhœa. I will remind you of the observations made by Neffel in such conditions, and which were regarded by him as visceral neuralgias (Lecture XXVI., page 258). In such cases of painful spasmodic menstruation, you may try Neffel's method first (An upon the dorsal and lumbar vertebræ, Ca upon the hypogastrium, ovaries, etc.); also the following methods: according to Schwanda, alternating faradic and galvanic treatment of the uterus; or, according to Taylor, the application of feeble continuous galvanic currents, the An upon the small of the back, the Ca in the form of a suitable metallic staff in the os uteri. Probably the best method is that of Dixon Mann, viz., the An in the uterus (uterine electrode), the Ca upon the lumbar spine stable for ten minutes, three times a week during the inter-menstrual period.

It was to be expected *a priori* that *menorrhagia* (and *metrorrhagia* in the broader sense) could be influenced favorably, under certain circumstances, by the electrical current, particularly on account of its vigorous stimulating action upon uterine contractions. Indeed, favorable results in this affection have been reported by various authors. Thus, Mackintosh observed cessation of a violent hemorrhage, after the delivery of the child, from the application of the faradic current to the cervix uteri and abdomen and the consequent production of uterine contractions. Dixon Mann has cured the affection by galvanization of the uterus (Ca in the uterus, An upon the loins, twice a week for fifteen minutes, with a tolerably strong current) in the intervals between the menstrual periods.

Among the changes in the uterus itself, *chronic metritis* particularly has been the subject of electro-therapeutic experiments. Beau and Tripier employ the faradic current. The former applies a moist sponge electrode

to the os uteri, the other electrode to the abdomen ; Tripier introduces one electrode into the uterus, the other (which is bifurcated) into the rectum and upon the anterior abdominal wall, or he faradizes percutaneously (in virgins) from the abdomen to the sacrum. Bartholow applied the galvanic current, the An (per speculum) upon the os uteri, the Ca upon the hypogastrium, two to three times a week, stable for five to ten minutes. Dixon Mann introduces into the uterus the Ca of a tolerably strong current, and places the An upon the lumbar region ; a few interruptions of the current at the close.

Displacements of the uterus have also been treated by the electrical current. Such treatment is not devoid of promise in those cases in which they are due in the main to relaxation of the walls of the uterus ; in many other cases there is very little hope of relief from such measures.

Even Simpson had recommended a sort of electrical intrauterine pessary in displacements of the uterus as well as in chronic metritis ; favorable results from electrical treatment of versions and flexions have been since reported by various observers. While Bartholow employed the galvanic current exclusively, E. Mann used galvanism and faradism alternately ; the majority of writers, however, applied the faradic current alone, in order to produce vigorous contractions of the uterus and thus relieve the change of position. As a rule, the current was passed from the os uteri to the abdominal walls. Zannini introduces one electrode into the rectum, the other into the uterus, and faradizes for five or six minutes with a current of gradually increasing strength.

Tripier has developed these methods most elaborately ; in anterior versions and flexions he faradizes the posterior surface of the uterus with a suitable electrode, which is placed in the rectum ; in similar posterior displacements the anterior surface of the uterus is faradized from the bladder or abdomen ; in both cases a (negative) electrode is introduced into the uterus. In prolapsus uteri, he states that good results have been observed from "bi-inguino-uterine" or "bi-inguino-vaginal" faradization.

I will refer also to the attempts which have been made to stimulate the insufficient secretion of milk by means of electrical currents. That this has been effected in a series of cases is evident from the observations of Aubert, Becquerel, Lardeur, and Estachy. Various methods of application are possible, but the majority of authors have applied the current directly, by means of moist electrodes, to various parts of the breasts ; the current should be moderately strong. The secretion of milk has returned as a rule after two or three sittings of ten to twenty minutes' duration. Static electricity has also been recommended as very serviceable.

In conclusion, permit me to make a few brief remarks which are perhaps of practical interest and to which there was no previous oppor-

tunity of referring. It has probably struck you that during our entire presentation of the subject the contra-indications to the use of electricity have not been considered in detail. But if you examine somewhat more closely into our conception of contra-indications with reference to the ordinary medicinal remedies, you will acknowledge that there can be scarcely any question of their existence with regard to a remedy which, like electricity, is capable of such an extraordinarily minute gradation and such a minimum dosage; which may produce the most varied, even antagonistic effects, here stimulating, there sedative, now tonic, again alterative in its action. And indeed, after a careful consideration of the subject, I must admit that I cannot present an absolute contra-indication; at the most, this may be presented not infrequently in the individual case, and then merely with regard to one or another form of application, rarely with regard to electricity in general.

In this respect, the condition of the circulation and blood-vessels seems to me to demand the chief consideration. One of the most striking effects of electricity is dilatation of the blood-vessels and increased flow of blood. The employment of electricity, at least the application of those methods which increase the flow of blood, is contra-indicated therefore in all cases in which increased blood-pressure or hyperæmia may entail danger on the patient. It should be avoided accordingly in acute inflammatory conditions, and especial caution must be employed in its application to individuals with sclerotic or atheromatous vessels, miliary aneurisms, hypertrophy of the heart, etc.

In the next place, the condition of the nervous system in general, its greater or less irritability, the manner of its reaction to the electrical stimulus, may be decisive with regard to the question of the applicability of electrical treatment. There are individuals who experience, in the good as well as the bad sense, a striking effect from electrical currents, while others are influenced thereby to a very slight extent. Nervous, neurasthenic, hysterical individuals often present an extremely high grade of "susceptibility," so that very feeble currents increase their sufferings. As a matter of course, this condition constitutes a contra-indication to the employment of electricity, while the milder grades of susceptibility merely afford grounds for extreme caution in the selection of the strength of the current; it is found not infrequently that such individuals become tolerant to electricity after prolonged treatment. In many cases, indeed, this very susceptibility of the patient is a not unfavorable prognostic factor with reference to the effects of electrical treatment.

I have now finished, and believe that I have given you a tolerably complete picture of the present status of electro-therapeutics in internal medicine. I am well aware that many gaps have been left, that there are many additional details which might have been communicated, and particularly that there is much which required more careful investigation before it was

made the basis for practical work. I hope that these gaps have not escaped your notice. And I trust that the subject has been presented in a clear light, and that, so far as lay in my power, at least, the way has been pointed out which should be followed among the confusing multiplicity of practical conditions. Although I have laid down clearly the principles and scientific basis of the practical manipulations which must be modified in so many ways, it has also been my object to unfold to you the scanty and uncertain condition of our actual knowledge in this field.

INDEX.

- ABDOMINAL** muscles, paralysis of, 208
- Acoustic** nerve, law of contraction of, 48
simple galvanic hyperæsthesia of, 96
galvanic hyperæsthesia of, with anomaly of normal formula, 99
paradox reaction of, 97
anomaly of reaction of, without hyperæsthesia, 100
torpor of, 101
- Active** electrode, 59
- Acute** anterior poliomyelitis, 175
- Acute** ascending paralysis, 179
- Acute** inflammation of joints, 329
- Agensis**, 334
- Amblyopia** and amaurosis without anatomical lesion, 314
cases: cerebral scotoma, 314; convergent strabismus, marked amblyopia of one eye, 314; traumatic anaesthesia of retina, 314
- Amenorrhœa**, 353
- Amyotrophic** lateral sclerosis, 179
- Anæsthesia**, 273
etiology, 273
electrical examination, 274
treatment, 276
cases: anæsthesia of trigeminus, 275; traumatic anæsthesia and paralysis of ulnar and median nerves, 275; anæsthesia of ulnar nerve, 275; lesion of right cerebral hemisphere, left hemianæsthesia, 275; right cerebral hemianæsthesia, 276; right hysterical hemianæsthesia, 276
- Anæsthesia** of trigeminus, 278
of pharynx and larynx, 278
vasomotor, 278
- Anæsthesia**, hysterical, 279
ataxic, 279
- Angio-neuroses**, cutaneous, 282
- Angio-paralysis**, cutaneous, 282
- Angio-spasm**, cutaneous, 282
- Anelectrotonus**, 42
- Angina** pectoris, 254
methods of treatment, 255
cases: idiopathic angina pectoris, 255; angina pectoris, 256
- Anidrosis**, 286
- Ankylosis**, 332
- Anode**, 4
- Anodal** action, 109
- Anosmia**, 325
- Aphonia**, hysterical, 294
- Apophyseal** point of Troussseau, 286
- Arthritis** deformans, 331
- Articular** neuroses, 252
- Artificial** respiration, 224
- Ascites**, 344
- Asthma**, nervous, 333
- Asphyxia**, 224
- Athetosis**, 302
- Atony** of vocal cords, 224
- Atrophy** of optic nerve, 310
primary, 312
genuine, 312
- BASEDOW'S** disease, 303
- Bladder**, spasm of, 346
weakness and paralysis of, 346
etiology of, 347
treatment of, 347
- Blepharospasm**, 270
- Brain**, effects of electricity upon, 53

- Brain, direct treatment of, 148**
 indirect treatment of, 150
 symptomatic treatment of, 151
 electro-diagnosis of, 151
 diseases of, action of electricity in, 138
 cases: cerebral neurasthenia, 139; emotional neurosis, hemiparesis of right side, 139; insomnia, mental depression, 139; hyperæmia of the brain (?), cerebral neurasthenia, 140; right hemiplegia (from cerebral hemorrhage?), 140; cerebral hemiplegia, sudden considerable improvement of the paralysis, 141; right hemiplegia, sudden improvement, 141; right hemiplegia and aphasia (from embolism?), 141; hemiplegia, probably from hemorrhage, 142; monoplegia of right arm with complete anæsthesia (probably from hemorrhage), 142; left hemiplegia (from hemorrhage?), 143; monoplegia of right arm (from embolism?), 143; right hemiparesis (anatomical diagnosis uncertain), 143; tremor of head, attacks of vertigo (incipient multiple sclerosis?), 143; left hemiplegia after acute encephalitis, 144; paralysis of numerous bulbar nerves, 144; bulbar symptom-complex (Erb), 145
- CARDIALGIA, 256**
Catalepsy, 301
Cataract, 308
Catalysis, direct, 107
 indirect, 110
Catelectrotonus, 42
Cathode, 4
Cathodal action, 110
Central galvanization, 118
 myelitis, 173
Cerebral hemorrhage, 153
 vessels, action of electricity upon, 138
 vessels, reflex action upon, 138
Cervico-brachial neuralgia, 249
Cervico-occipital neuralgia, 246
Choked disk, 309
Chorea magna, 297
 minor, 298
- Choroid, diseases of, 309**
 case: chronic retino-choroiditis, 309
Chronic meningitis, 154
 inflammation of joints, 330
Ciniselli's simple element, 120
Circular current of Remak, 252
Circuit of closure, 3
Concussion of spinal cord, 171
Conditions of mental depression and exaltation, 157
Colic, 257
Conducting wires, 14
Conduction, resistance to, 21
 variations in, 22
Constancy of elements, 9
Contact electricity, 2
Contractions, diplegic, 92
 galvano tonic reflex, 93
Contra-indications to use of electricity, 356
Convulsive reaction, 89
Convulsions, nature of, 259
 pathogenesis, 260
 electrical examination, 261
 methods of treatment, 267
 cases: facial spasm, 263; bilateral facial spasm (blepharospasm), 263; clonic spasm of facial muscles, 264; spasm of splenius, 264; spasm of neck muscles, 264; rheumatic torticollis, 265; contracture of levator anguli scapular, 265; nervous pertussis, 265; singultus with weakness of arm, 265; spasm of recti abdominis and latissimi dorsi, 265; tremor of right arm, 265; clonic spasm of lower limb, 266; hemiplegic contracture, 266; rheumatic contracture, 266; contracture in compression-myelitis, 266; hysterical contracture, 266; reflex contracture of quadratus lumborum, 266
Convulsive tic, 270
Cornea, ulcers of, 307
Current, faradic, 2
 galvanic, 2
 density of, 27
 diffusion of, 28
 methods of localization of, 30
 electrolytic action of, 31
 mechanical action of, 32

- Current, cataphoric action of, 83
stimulating effects of, 105
modifying effects of, 106
catalytic effects of, 107
- Cutaneous angiospasm, 288
angioparalysis, 288
- DEGENERATION** reaction, 74
irritability of nerves in, 75
irritability of muscles in, 76
anatomical appearances of nerves in, 79
anatomical appearances of muscles in, 80
partial, 82
occurrence of, 83
importance of, with regard to prognosis, 86
double contraction in, 87
- Density of the current, 27
- Diabetes mellitus, 304
insipidus, 305
- Diaphragm, paralysis of, 206
- Diminution of secondary irritability, 89
- Diphtheritic paralysis, 225
symptomatology, 225
electrical examination, 225
cases: ataxia, 226; diphtheritic paralysis, 227
methods of treatment, 227
- Diplegic contractions, 92
- Diseases of the brain, 187
of the medulla oblongata, 154
of the spinal cord, 160
of the peripheral nerves, 180
of the cervical sympathetic, 280
of the organs of special sense, 306
of the organs of locomotion, 327
of the glands, 332
of the thoracic viscera, 333
of the digestive apparatus, 336
of the urinary and sexual organs, 345
- Dubois-Reymond's law of irritation, 83
- Dysmenorrhœa, 354
- Dyspepsia, nervous, 337
- EAR**, electrical examination of, 65
- Entropium, 307
- Electricity, contact, 2
- Electrical bath, 118
- Electrical currents, reflex effects of, 112
- Electrical brush, 18
moxa, 242
- Electrical irritability of motor nerves and muscles, increase of, 69
irritability of motor nerves and muscles, diminution of, 71
irritability of sensory nerves, changes in, 93
irritability of sensory nerves, hyperæsthesia of, 93
irritability of sensory nerves, anaesthesia of, 93
irritability of optic nerve, changes in, 95
irritability of acoustic nerve, changes in, 96
- Electrodes, 5, 15
active, 38
indifferent, 38
for general faradization, 116
unpolarizable, 17
- Electrolysis, 31
- Electrolytes, 31
- Electrolytic effects, 56
- Electro-motor power, 3
- Electro-muscular sensibility, 45
sensibility examination of, 67
- Electro-therapeutics, electrotonic theory of, 104
stimulation, theory of, 104
catalytic theory of, 105
polar method of, 113
direction method of, 113
- Electrotonic action of current, 49
- Electrotonus, 42
- Elements, constancy of, 9
- Element numerator, 11
- Endolaryngeal electrization, 228
- Endopharyngeal electrization, 228
- Enteralgia, 257
- Entropium, 307
- Enteropathy, nervous, 339
- Epilepsy, 294
treatment of, 295
- Epileptic insanity, 158
change, 294
- Essential cyanosis, 283
redness, 283
resistance of a chain, 25
- Examination, polar method of, 59
- External auditory canal, abnormal dryness of, 317

- External skin, electro-physiology of, 53
 Extra-essential resistance, 25
 Extra current, 7
 Eye, electrical examination of, 64
- FACIAL** nerve, paralysis of, 199
 spasm of, 270
 Faradic current, 2
 Faradization, general, 116
 local, 121
 Functional diseases of the cord, 171
 neuroses, 288
- GALVANIC** current, 2
 taste, 49
 vertigo, 53
 Galvanization of the neck, 111
 of the sympathetic, 111
 general, 117
 central, 118
 Galvanometer, 13
 Hirschmann's, 13
 Galvano-cautery batteries, 26
 Galvano-tonic reflex contractions, 98
 Gall-bladder, effects of electricity upon, 54
 Gastralgia, 256
 General faradization, 116
 Globus hystericus, 294
 Goitre, 333
 Gustatory nerves, neuroses of, 324
- HEADACHE**, 247
 Heart, nervous palpitation of, 335
 weakness and irregularity of, 335
 Hemeralopia, 315
 Hemianopsia, 315
 Hemiorania, 247
 Herpes zoster, 285
 Hemorrhages into the brain, 153
 into the spinal cord, 172
 Hiccough, 271
 Hydrocephalus, 154
 Hydrops articularum intermittens, 285
 Hyperidrosis, 286
 Hyperkineses, professional, 295
 Hypochondriacal melancholia, 158
 Hypochondriasis, 292
 Hypoglossal nerve, paralysis of, 204
 Hypopyon, 307
 Hysteria, 292
 Hysterical psychoses, 157
- Hysterical paralysis, 293
 anesthesia, 294
 convulsions, 294
 aphonia, 294
- IMPOTENCE**, 352
 Incontinence of urine, 346
 Increase of secondary irritability, 69
 Indifferent electrode, 38, 59
 Indirect catalysis, 110
 Induction, electricity, 5
 apparatus, 5
 Infantile spinal paralysis, 175
 electrical examination, 175
 treatment, 176
 Insomnia, 153
 Interrupting handle, 17
 Intercostal neuralgia, 250
 Intestines, effects of electricity upon, 55
 occlusion of, by stasis of feces, 309
 invagination of, 341
 atony and constipation, 341
 atony and constipation, cases: epilep-
 sy. severe constipation, 341; nervous
 headache, habitual constipation,
 341; gunshot wound of abdomen
 and spine, obstinate constipation,
 341; obstinate constipation after
 peritonitis, 342; habitual constipa-
 tion, 342
- Ions, 32
 Irritability of nerves, quantitative deter-
 mination of, 60
 with faradic current, 63
 with galvanic current, 63
 Ischuria, spasmodic, 346
- JOINTS**, stiffness of, 333
- KATATONIA**, 157
 Keratitis, parenchymatous, 307
 neuro-paralytic, 307
- LABILE** action, 106
 Latent period of irritation in faradic stim-
 ulation of muscles, 91
 Lateral sclerosis, amyotrophic, 179
 descending, 179
 Law of contraction of nerves, 38
 qualitative changes in, 90
 Lead palsy, 228

- Lead symptomatology, 228
 electro diagnosis, 229
 treatment, 230
- Livor angio-neuroticus, 263
- Local faradization, 121
- Lymphatic glands, enlargement of, 333
- MAGNETO-ELECTRICAL** apparatus, 5
- Male sexual organs, functional disturbances of, 350
 symptomatology, 351
 treatment, 352
- Melancholia, 158
- Menière's disease, 324
- Meningeal apoplexy, 171
- Menorrhagia, 354
- Metritis, 354
- Migraine, 247
 nature, 248
 treatment, 248
- Milk, deficient secretion of, 355
- Milliveber, 18
- Modifying action of current, 42
- Monoarticular chronic articular rheumatism, 330
- Motor nerves, law of contraction of, 38
- Moxa, electrical, 242
- Multiple sclerosis, 154
- Muscles, law of contraction of, 40
- Muscles of mastication, paralysis of, 199
- Muscular atrophy, 231
 electro-diagnosis, 231
 treatment, 232
 cases: paralysis and atrophy of quadriceps from gonitis, 232; traumatic hydrarthrosis of knee, atrophy of quadriceps, 232
- Muscular rheumatism, 327
- Myalgia, 327
- Mydriasis, 198
- Myelitis, 173
- Myotonia congenita, 233
- NECK**, galvanization of, 111
- Negative pole, 4
- Nerves, different reaction of, to faradic and galvanic currents, 91
- Nervous asthma, 333
- Nervous deafness, 328
 cases: deafness without demonstrable anatomical change, anomalous galvanic reaction, 323; deafness with anatomical change, torpor of acoustic nerve, 324
- Nervous exhaustion, 290
- Neuralgia, 234
 nature, 235
 symptomatology, 236
 electrical examination, 236
 treatment, 240
 cases: intermittent supra-orbital neuralgia, 237; trigeminal neuralgia, 238; occipital neuralgia, 238; neuralgia of median nerve, 238; neuralgia of radial nerve, 238; neuralgia of lesser internal cutaneous nerve, 239; intercostal neuralgia, herpes zoster, 239; intercostal neuralgia, mastodynia, 239; sciatica, 239, 240; neuralgia of foot from articular rheumatism, 240
- Neuralgia of lumbar plexus, 250
 of urinary and sexual organs, 252
 of joints, 252
 of pharynx and larynx, 254
 of cardiac nerves, 254
 of gastric nerves, 256
 of intestinal nerves, 257
 of pelvic nerves, 257
- Neuralgic change, 235
- Neurasthenia, 290
 symptomatology, 290
 treatment, 291
- Neuritis, optic, 310
 retrobulbar, 310
- Neuroses of gustatory nerves, 324
 of olfactory nerves, 325
- Nocturnal enuresis, 348
- Nystagmus, 315
- OCULAR** muscles, paralysis of, 196
- Oesophagus, effects of electricity upon, 55
 spasm and paralysis of, 336
 sensory neurosis of, 336
- Ohm's law, 19
- Olfactory nerves, neuroses of, 325
- Opacities of tympanum, 317
- Open chain, 3
 element, 3
- Optic nerve, law of contraction of, 46
 atrophy of, 310
 primary, 312

- Optic nerve, atrophy of, genuine, 313
 cases: atrophy of optic nerves, 313;
 beginning atrophy of optic nerves,
 313; white atrophy of optic nerves,
 313, 314
- Optic neuritis, 310
 cases: optic neuritis and subacute dor-
 sal myelitis, 310; optic neuritis
 with transverse myelitis, 310; neu-
 ritis with atrophy of optic nerve, 311
- Orochitis, blenorrhagic and traumatic, 350
- Organs of locomotion, diseases of, 327
- PAIN, nature of, 235**
- Painful points of Valleix, 119, 236
- Palpitation of heart, 335
- Papillitis, 309
- Papillo-retinitis, 309
- Paralysis, definition of, 187
 causes of, 187
 sequelæ of, 187
 treatment of, 188
 reflex stimulation in, 189
 electro-diagnosis of, 193
 occurrence of degenerative atrophy
 in, 194
- Paralysis agitans, 302
 after acute diseases, 228
 of deglutition, 219
 symptomatology, 219
 electro-diagnosis, 220
 treatment, 221
 cases: paresis of velum palati, 220;
 diphtheritic paralysis of velum pa-
 lati, tensor of choroid and sphincter
 of pupil, 220; diphtheritic paraly-
 sis, 220
- of facial nerve, 199
 forms of, 200
 treatment of, 202
- of hypoglossal nerve, 204
 of laryngeal muscles, 223
 of lower limbs, 214
 etiology, 215
 symptomatology, 215
 electro-diagnosis, 216
 treatment, 218
 cases: paresis of crural nerve, 216;
 paresis of sciatic nerve, hypertrophy
 of calf muscles, 216; paralysis of
 peroneal nerve, 217; paralysis of
- peroneal nerve from cicatrization of
 bed-sore, 217; traumatic paralysis
 of peroneal nerve, 217
- of muscles of mastication, 199
 of muscles of neck and trunk, 206
 cases: paralysis of serratus magnus,
 207; paralysis and atrophy of dia-
 phragm, 207; progressive muscular
 atrophy (juvenile form), 207
- of ocular muscles, 196
 treatment, 198
 cases; rheumatic paralysis of abdu-
 cens, 197; paralysis of right oculo-
 motor nerve, 197; paralysis of troch-
 learis and insufficiency of rectus
 internus, 197; bilateral paresis of
 rectus internus and rectus externus,
 197
- of spinal accessory, 204
 of upper limbs, 208
 etiology, 209
 symptomatology, 209
 electro-diagnosis, 210
 treatment, 213
 cases: paralysis of musculo-cutane-
 ous nerve, 211; paralysis of me-
 dian and musculo-cutaneous nerves,
 211; paresis of ulnar nerve, 211;
 "crutch" paralysis of radial nerve,
 212; "sleep" paralysis of radial
 nerve, 212; traumatic paralysis of
 radial nerve, 212; combined shoul-
 der-arm paralysis, 212, 213; trau-
 matic paralysis of radial, median,
 and ulnar nerves, 213
- Paralysis of vocal cords, 222
- Paralytic aphonia and dysphonia, 223
- Pathophobia, 292
- Periarthritic swellings, 332
- Periencephalitis, 154
- Peripheral nerves, diseases of, 180
 diseases of, available action of elec-
 tricity in, 180
 diseases of, methods of application in,
 184
 diseases of, cases: chronic neuritis of
 median nerve, 181; chronic neuritis
 nodosa of ulnar nerve, 181; neuritis
 of brachial plexus, combined shoul-
 der-arm paralysis, 181; paralysis of
 deltoid, 182; traumatic paralysis of

- left arm, 182; paralysis of right
 radial nerve, 183; neuralgia of
 brachial plexus, 182; neuralgia of
 ulnar nerve, 183; right occipital
 and trigeminal neuralgia, 183; left
 sciatica, 183; right supraorbital
 neuralgia, 183; neuralgia of super-
 ficial branch of radial nerve, 183;
 trigeminal neuralgia, herpes labialis,
 183; retrobulbar optic neuritis, 184;
 white atrophy of optic nerve, 184
- Pflueger's law of contraction,** 34
Pharynx, effects of electricity upon, 55
Pharyngeal and laryngeal electrode, 221
Polarity changer, 11
 Brenner's modification of, 12
Polar method of examination, 59
**Polyarticular chronic articular rheuma-
 tism,** 331
Poles, means of recognition of, 18
Portable batteries, 9
Positive pole, 4
Pressure points, 119
Primary spiral, 6
 current, 6
Professional hyperkineses, 295
Progressive bulbar paralysis, 154
 facial hemiatrophy, 286
 muscular atrophy, 177
Prolapsus ani, 343
Prostate, inflammation and swelling of,
 350
Pseudo-hypertrophy of muscles, 232
Psychoses, 156
 methods of application in, 157
 contraindications of electricity in, 159
- RAILWAY spine,** 171
Reaction of exhaustion, 89
Rectal neuralgia, 258
Reflex effects of electrical currents, 112
Resistance to conduction, 21
Respiratory paralysis, 224
Retention of urine, spasmodic, 346
Retina, law of contraction of, 46
Retinitis pigmentosa, 309
Retino-choroiditis, 309
Retrobulbar neuritis, 310
Rheo-tat, 14
Rheumatic torticollis, 271
Rheumatismus nodosus, 381
Rotation apparatus, 5
- SACROLUMBALES, paralysis of,** 208
Sciatica, 251
Scleroderma, 287
Secondary irritability, increase of, 89
 diminution of, 89
Secondary spiral, 6
Secretory nerves, electro-physiology of, 54
Selector, 11
**Sensibility of skin, electrical examination
 of,** 66
 electrode for examination of, 67
Sensory nerves, law of contraction of, 44
Serratus magnus, paralysis of, 208
Sexual organs, male, diseases of, 350
 female, diseases of, 353
Siemen's unit, 21
Simple element, 3
Singultus, 271
Softening of brain, 154
Spasm in distribution of facial nerve, 270
 of muscles of mastication, 269
 in distribution of spinal accessory, 270
 of respiratory muscles, 271
 of upper limbs, 272
 of lower limbs, 272
Spastic spinal paralysis, 174
Spermatorrhœa, 352
Sphincter, paresis of, 343
Spinal accessory nerve, paralysis of, 204
Spinal cord, effects of electricity on, 54
 diseases of, actions of current in, 160
 electrical applications in, 167
 action of poles in, 168
 indirect electrical treatment of, 168
 reflex irritation in treatment of, 169
 symptomatic treatment of, 169
 cases: subacute spinal meningitis,
 161; chronic spinal meningitis (?),
 161; spinal concussion, 162; para-
 plegia (from acute myelitis?), 162;
 traumatic paraplegia, 162; myelo-
 pathy (tabes dorsalis?), 162; tabes
 dorsalis, 163, 164, 165; beginning
 tabes dorsalis (?), with atrophy of
 optic nerves, 163; affection of spinal
 cord (tabes?), 165; spastic spinal
 paralysis, 165; subacute anterior
 poliomyelitis, 165; chronic anterior

- poliomyelitis, 166 ; progressive muscular atrophy, 166
 Spinal cord, concussion of, 171
 hemorrhage into, 172
 traumatic lesions of, 172
 secondary degeneration of, 179
 meningitis, 170
 irritation, 172
 neurasthenia, 172
 Spices. effects of electricity on, 55
 enlargement of, 333
 Stiffness of joints, 332
 Stomach, effects of electricity on, 55
 atony and dilatation of, 338
 Subacute and chronic anterior poliomyelitis, 177
 Subaural galvanization, 111
 Sympathetic system, electro-physiology of, 50
 galvanization of, 111
 irritation of, 281
 paralysis of, 281
- TABES dorsalis**, direct electrical treatment, 174
 symptomatic peripheral treatment, 174
 treatment of pressure and painful points, 174
 application of faradic brush, 174
Taste, electrical examination of, 65
 paralysis of, 324
Tenesmus vesicæ, 346
Tension series, 3
Tetanus, 299
Tetany, 300
Testicles, atony and flaccidity of, 350
Thoracic viscera, effects of electricity upon, 54
Tinnitus aurium, 317
 electro-diagnosis, 318
 methods of treatment, 321
 cases; simple galvanic hyperæsthesia with tinnitus aurium, 318, 320; tinnitus aurium after administration of quinine, simple galvanic hyperæsthesia, 319; impairment of hearing and tinnitus aurium; bilateral hyperæsthesia of acoustic nerve, paresis of abducens nerve, 319; tinnitus aurium and impairment of hearing, simple hyperæsthesia of both acoustic nerves, 320; Chronic buzzing in head and tinnitus aurium with impairment of hearing, hyperæsthesia with paradox formula, 320; impairment of hearing and tinnitus aurium, hyperæsthesia with reversal of normal formula, 321; impairment of hearing and tinnitus aurium after cerebro-spinal meningitis, 321
Torticollis, 271
Transverse myelitis, 173
Toxic paralyzes, 230
Trachoma, 307
Tremor, 301
Trigeminal neuralgia, 245
Trismus, 269
Trousseau's apophyseal point, 236
True hypertrophy of muscles, 233
- UNPOLARIZABLE electrode**, 17
Urinary bladder, effects of electricity on, 55
Urinary organs, diseases of, 345
- VALLEIX**, painful points, 119, 236
Vasomotor nerves, law of contraction of, 50
 anæsthesia, 278
 neuroses, 282
Velum palati, effects of electricity on, 55
Vertigo, 304
 galvanic, 53
Vesical electrization, 55
Virtual pole, 37
Visceral neuralgias, 258
Vitreous body, diseases of, 306
Volta's alternatives, 35
Vomiting, nervous, 336
- WIRE brush**, 18
Writer's spasm, 295