

A PRACTICAL TREATISE  
ON THE  
MEDICAL AND SURGICAL USES  
OF  
ELECTRICITY.

INCLUDING:  
LOCALIZED AND GENERAL FARADIZATION; LOCALIZED AND CENTRAL  
GALVANIZATION; FRANKLINIZATION; ELECTROLYSIS AND  
GALVANO-CAUTERY.

BY  
GEO. M. BEARD, A.M., M.D.

*Fellow of the New York Academy of Medicine; Member of the American Academy of Medicine; Member of the American Neurological Association; of the New York Neurological Society, etc.*

A. D. ROCKWELL, A.M., M.D.

*Fellow of the New York Academy of Medicine; Member of the American Academy of Medicine; Member of the American Neurological Association; Electro-Therapeutist to the Woman's Hospital of the State of New York, etc.*

Third Edition. Revised by

A. D. ROCKWELL, M.D.

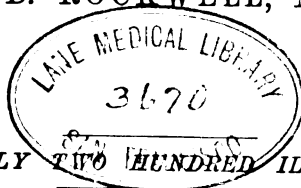

WITH NEARLY TWO HUNDRED ILLUSTRATIONS.

NEW YORK  
WILLIAM WOOD & COMPANY, PUBLISHERS  
56 & 58 LAFAYETTE PLACE

1883

A

W. WOOD & CO.

COPYRIGHT,  
WILLIAM WOOD & COMPANY  
1881.

TROW'S  
PRINTING AND BOOKBINDING COMPANY  
201-213 East 12th Street  
NEW YORK



2871  
3368  
1883

TO

JOHN T. METCALFE, M.D.,

PROFESSOR OF CLINICAL MEDICINE IN THE COLLEGE OF PHYSICIANS  
AND SURGEONS, NEW YORK,

*THIS WORK IS DEDICATED,*

WITH THE GRATEFUL ESTEEM

OF

THE AUTHORS



## PREFACE TO THE FOURTH EDITION.

---

It is with much satisfaction that Dr. Rockwell offers to the profession a fourth revised edition of this work. When, with the late Dr. George M. Beard, he first sent it forth upon its mission, a pioneer in a neglected and perhaps despised department of medicine, it was, both on the part of authors and publisher, with some misgivings as to its success. While the measure of its merits as a guide in the department of which it treats may fall far below the generous reception accorded to it, both at home and abroad, the fact that each successive edition has been exhausted more rapidly than its predecessor, notwithstanding the widening literature of the subject, affords ample encouragement for further revision.

The chapter on Franklinic Electricity has been entirely rewritten. This was rendered necessary by the many improvements in apparatus and appliances, and its great value as an adjunct or supplement to dynamic electricity. Experience has demonstrated, also, that in a number of pathological conditions it is even superior to the other forms of electricity. It should not, however, be forgotten that Franklinic Electricity has in general a narrower range of usefulness than dynamic, and that in the study of electro-therapeutics the latter should precede the former. But perhaps the most important of the new matter that has been introduced relates to the experience of the author in the treatment of Extra-Uterine Pregnancy.

Formerly, as is well known, these cases resulted either in immediate death, through rupture of the distended tube, or in protracted suffering, with frequently a fatal ending, through the efforts of nature to rid itself of the foetal mass. The only other alternative was the knife, with its attendant dangers. By the method described, however, and used with such complete success in every instance, this abnormality of pregnancy

need not in the future be regarded as such a dreaded complication as it has been in the past.

The operation is simple in its details and certain in its results ; is attended with but comparatively little suffering or danger to the mother, and cannot but commend itself to the profession everywhere.

Extra-Uterine Pregnancy is doubtless more frequent than is generally supposed, and because of the difficulty of an early diagnosis, death frequently occurs without any previous knowledge of the existing condition of affairs. It behooves, therefore, every practitioner to be on the alert for this condition in its earlier stages, when this method of treatment is so efficacious.

A. D. ROCKWELL,

*46 East Thirty-first Street, New York.*

## PREFACE TO THE THIRD EDITION.

---

IN issuing a third edition of this work I have endeavored to make such additions as seemed necessary, and at the same time avoid an increase in size. This has been accomplished by condensing wherever possible, and omitting portions here and there which have served their purpose and are no longer of value. Two new chapters on the Sequelæ of Acute Diseases and on Exophthalmic Goitre, respectively, have been inserted, while several pages in the discussion of Electro-diagnosis have been omitted, and the space occupied by later and more exact information. The chapter on Diseases of Women has been revised, and the clinical additions will be found interesting and suggestive, while in the discussion of Midwifery the complication of Extra-Uterine Pregnancy is fully considered.

These, together with many other changes and brief additions throughout the work, have, it is believed, materially enhanced its practical value.

The position of electricity in the front rank of sedatives and tonics, and the pre-eminent value of the methods of general faradization and central galvanization, as means of obtaining the full measure of these effects (claims in regard to which the authors of this work once stood alone), have now been so long confirmed by expert observation in this country and Germany that extensive demonstration of these propositions by cases is less needed than formerly.

In regard to the theory of Dr. Thomas W. Poole, of Lindsay, Canada, that electricity is essentially a paralyzing agent, and that its sedative and tonic effects are due to its paralyzing power, this may be said: That, granting for a moment the full claim, it yet remains, that practically, we do obtain from the use of electricity sedative and tonic effects similar to those which we obtain from a vast number of other remedial agencies. Allowing that these effects are resultants of a

paralyzing influence it is none the less justifiable, on scientific and practical grounds, to use the terms sedative and tonic.

The final rationale of no work or remedial force of any kind is completely known to science, and, for practical uses, it is not necessary that it should be ; we, perhaps, know as much of the rationale of electricity as of any agent that we use for the cure of disease.

The more thoroughly one studies electro-therapeutics in all its relations, medical and surgical, the clearer it becomes that the real scientific basis for the use of electricity in medicine and surgery is found in electro-physics more than in electro-physiology ; and for that reason it did not seem wise to very much abbreviate the portion of this work allotted to that department. The rationale of general faradization and central galvanization, for example, can only be understood by those who have grasped the elementary principles of electro-physics, the laws of resistance and conductivity, and, above all, the law of Ohm, to which we have assigned a special chapter. Those who have been once well grounded in these laws of electro-physics find that the various special problems that arise, whether of a theoretical or practical character, very quickly resolve themselves.

Now that electricity has become popular in medicine, there is, in some quarters, a temptation to overdo the application, not only in strength but in length and frequency ; to treat all cases alike by routine, mechanical applications, regardless either of the disease or the idiosyncrasies of the patient ; hence, in cases not a few, come results either negatively or temporarily injurious, with disappointment on all sides.

The dosage of electricity is a special study of the greatest practical importance ; the difference in result between a very gentle and short application and a very strong and protracted one being, in some cases, all the difference between agreeable success and painful failure.

There are persons who must be treated not only mildly but at long intervals, and there are persons with, perhaps, the same maladies that can bear with advantage powerful and frequent applications ; to distinguish between these classes and the various gradations that lie between the extremes of tolerance and of susceptibility is the first duty, and, oftentimes, the hardest study of him who makes much use of electricity in medicine.

## PREFACE TO THE SECOND EDITION.

---

A FEW weeks after the publication of the first edition of this work, in 1871, we were informed by the publishers that a new edition would be called for. From that time to the present moment much force has been expended on the thorough revision of the work in all its departments. As much time and toil, it is safe to say, have been given to this edition as to the first; and the work as it now stands represents our accumulated and thoroughly sifted experience from our entrance upon this specialty, as well as a full and exhaustive résumé of all that has been accomplished by other authorities everywhere.

About one year ago, while this edition was in press, we amicably dissolved the professional association that had existed for six years, and during which all our writings on this subject had appeared. This dissolution of our business relations has not affected the present work except so far as to delay somewhat its publication.

The success of the first edition of this work has far surpassed our highest hopes; and our belief is that it may have done something to raise the standard of electro-therapeutics as well as to popularize it. More than a year since, the work was translated into German by Dr. Väter, of Prague, who has confirmed all that we have claimed in regard to the efficacy of general electrization, and who has followed up the translation by a series of elaborate articles, didactic and clinical, on general electrization and central galvanization in the *Allgemeine Wiener Zeitung*.

The use of general faradization as a constitutional tonic in a wide variety of affections is now well established and the effects that we have claimed for it have been confirmed in full detail by competent observers at home and abroad. This method of using electricity has also attained a wide popularity, and its introduction into therapeutics may be said to have marked a radical and important advance.

The section on Electro-physics is much enlarged. Observation has convinced us that the one great defect in those who practise electro-therapeutics is ignorance of the physical relations of electricity. From

this source flow at least half the blunders, discouragements, and ill success that novices in this branch so painfully experience. The undulatory theory of the electrical force that is adopted in this edition is, so far as can now be seen, consistent and harmonious, and it explains better than any other theory the varied and complex phenomena of electro-physiology and electro-therapeutics.

The chemistry of the batteries, it will be seen, is explained in full detail, and in accordance with recent chemical facts and nomenclature.

To Ohm's Law, at once so important and so difficult, a separate and special chapter has been assigned; and no effort has been spared to make it clear in all its practical relations to all trained minds who will give it close and careful attention.

In the preparation of the section on Electro-physics we have been favored with the advice and suggestions of a number of our most distinguished physicists and mathematicians; and especially are we indebted to Prof. Henry T. Eddy, of Cincinnati, who has interested himself in the attempt here made to put the most recent theories and facts of electro-physics in a shape at once clear, compact, and trustworthy.

The need of a section of this kind has been most urgent, for the treatises on the physics of electricity that have been most accessible are either far behind the time or have been expressed so blindly as to be of little value to electro-therapeutists. Even the best of the more recent writers on the physics of electricity, as Fleming Jenkins, and Latimer Clarke, have not adapted their works to the wants of those who use electricity in therapeutics.

Electro-physiology is largely rewritten and considerably enlarged. It includes a large number of our own experiments, mostly made during the past three years, as well as a compact résumé of all the more recent studies in this branch by European and American observers. The general relation of electro-physiology to electro-therapeutics has been brought into prominence at every point.

The method of *central galvanization* that we have systematized and introduced to the profession since the publication of the first edition is here described and illustrated in full detail. The great practical advantages of this method of galvanization over localized galvanization of the nerve-centres—and in many cases over general faradization—are already well understood by many of our leading electro-therapeutists.

There are now introduced into science, six methods of using electricity for the treatment of disease: localized faradization and localized galvanization, general faradization, central galvanization, and, in electro-surgery, electrolysis and galvano-cautery.



In the chapter on Apparatus we have endeavored to represent with fairness and impartiality the best workmanship and the most recent improvements. The fact of the superiority of continuous over separate-coil Faradic-machines in the treatment of sensitive patients is here for the first time brought out and emphasized.

A new chapter on General Suggestions has been added, in which the attempt has been made to answer in detail the various practical queries that so annoy the beginner in electro-therapeutics.

In the section on Electro-surgery the principles of galvano-cautery, of ordinary electrolysis, and of the method of electrolysis of the base have been described and illustrated, and in the clinical portions all varieties of results have been presented from a very large experience in this department, so that one may learn both what can be done and what cannot be done by electricity in surgical diseases.

In the clinical part of electro-medicine a number of entirely new chapters have been added, and all of the chapters have been recast. The number of cases has been increased nearly twofold, the failures and successes being fairly represented.

We may call especial attention to the chapters on Diseases of the Skin, wherein, besides many other cases, are detailed the remarkable results of central galvanization in chronic eczema and prurigo, and to the chapter on Diseases of Children, in which are recorded the results of experiments in the treatment of whooping-cough, marasmus, and debility, and also the fact of the remarkable tolerance of childhood to electricity. Since the publication of the first edition a number of excellent works on nervous diseases have appeared, and for that reason, as well as for lack of space, the systematic remarks on certain diseases have, in this edition, been mostly omitted, save some special points wherein our views differ from those generally adopted.

Although the work is considerably enlarged yet this enlargement is due more to the addition of new matter than to the retention of old. If there are any who object to the size of the work, who seek for short and ready methods to the science and art of electro-therapeutics, who despise and deride the physical and physiological relations of electricity, and who suppose that he who has held two sponges on a patient has compassed the whole of electrology, we can only reply that it is not for such that this book was written, and we hope that nothing we may write will encourage the increase of physicians of that character. The ideal of every electro-therapist—certainly of every one who gives the subject special attention—should be to become an electrologist, that is, to be a master of electricity in its physical and physiological as well as

its purely diagnostic and therapeutic relations ; for all such this edition is designed to be a work of exhaustive reference. Those, however, whose aims are lower will here find the purely practical and clinical department clearly presented by a large variety of illustrations of the various methods of application, and by details of more than two hundred cases, including every type of medical and surgical disease, for which electricity by any method of application has been used with any encouraging results.

To those who, since the first edition of this work was out of press, have grown weary in waiting for the long-promised appearance of the second edition, we may express the hope that they will find in the present treatise sufficient evidences of original experience and research to fully account for, if not to justify the annoying delay.

## PREFACE TO THE FIRST EDITION.

---

THE object of this work is to present, in a compact, practical form, all that is now known on the application of electricity to the treatment of disease. The aim of the authors has been to combine their own extensive and varied researches with localized and general electrization, and the labors of all other recent explorers in electro-therapeutics, in a summary which should be at once practical and exhaustive, and which should represent with strict impartiality all that has been really accomplished in this department by every school, in every country, and by all methods.

For this undertaking the authors have been prepared by an experience acquired in more than 10,000 applications of electricity in a wide variety of morbid conditions, and by personal observation of the methods and the results of the recognized leaders in this important field of science.

For convenience of reference, and in order to avoid repetition and confusion, the work is divided into *Electro-Physics*, *Electro-Physiology*, *Electro-Therapeutics*, and *Electro-Surgery*. It is believed that by this arrangement the work will be more acceptable both to the majority who seek to consult the distinctively practical portions, and to the few who may desire also to investigate the subject of electricity in its physical and physiological relations.

General electrization, which the authors were the first in the profession to systematically investigate, is here, for the first time, described and illustrated in systematic detail of its modus operandi and its very remarkable effects in conditions of debility.

The general differential indications for the use of the two currents and for the use of localized and general applications, we have sought to distinguish and elucidate by logical deductions from the known principles of electro-therapeutics, and, above all, from extended experimental comparison. The knowledge of electro-therapeutical anatomy, which is so essential for an intelligent electro-diagnosis in therapeutics, we have endeavored to facilitate by concise and explicit illustrations. The drawings for illustrations of the different methods of electrization were made from photographs taken during the applications.

In the selection and detailed description of apparatus, both the taste of the specialist and the imperative needs of the general practitioner have been constantly borne in mind ; and while nearly all the most improved forms of machines for both currents have received notice, minute description and illustration have been reserved only for those that experience has shown unite in the highest degree the qualities of convenience and compactness, with accessibility and uniformity of action. When we began our experiments in this department, there was in this country no satisfactory apparatus either for the faradic or the galvanic current, and for this reason our early observations were made under exceeding disadvantages.

The difficulty has for a number of years been partly met by the electro-magnetic apparatus of Kidder, which, for all the essential qualities required, is as yet unsurpassed. We early became convinced that scientific electro-therapeutics required also a galvanic apparatus which should be at least more compact and more portable than those which had been usually employed, and that to be forced to depend on apparatus of foreign construction would both retard the progress and practically prohibit the popularization of electro-therapeutics. Amid many discouragements which only those who have pursued similar investigations can well appreciate, we have striven to overcome this serious evil and to prepare a galvanic apparatus which should be both simple and enduring, and which could be used at the bedside as well as in the hospital or consulting-room. Through the skill and intelligence of the mechanic above-mentioned, we are now able to present an apparatus for the galvanic current which, if not on the one hand so compact, or on the other so elaborate as others to which we have called attention, is yet, in the wide variety of size and shape of which it is capable, in the simplicity of its construction, and the ease of its management, perhaps even better fitted to supply the general want.

*Electro-surgery*, though a young and as yet but little developed branch of electro-therapeutics, is yet of such intrinsic importance and interest, and so fruitful in promise for the future, that it has been deemed worthy of separate and special consideration.

In the preparation of the detailed and statistical reports of cases, we have sought to give a picture that shall be so accurate, and so true to experience, that it may be unfailingly recognized by all those who pursue a similar line of experiment. The somewhat deserved reproach against electro-therapeutists, that they publish only their most fortunate results, we have endeavored to avert by giving prominence to failures as well as to successes ; by noting relapses as well as permanent re

coveries. We have been not unmindful of the fact that statistical reports of the results of any method of treatment, however conscientiously prepared, must be at best incomplete, and to a certain extent illusory. Therapeutics is always a subject of vast complications. It is probable that in some of the cases reported as absolute or approximate recoveries, nature and time, and in a few instances, perhaps, other medicinal or hygienic treatment bore as large a share as the applications themselves. We have, however, endeavored to make all proper allowances for the influence of these various factors; and in the few exceptional cases where medicinal has been combined with electrical treatment, the fact has been mentioned, and cases of positive doubt have been excluded from consideration. For the study of the special effects of electrical treatment, when used alone, we have been peculiarly fortunate, since the vast majority of our cases had abandoned medication before they were referred to our care. On the other hand, it is indisputably true that some of the cases reported as absolute failures, or as but slightly benefited, were kept from perfect recovery by the indulgence of evil habits of hygiene; and it is fully probable that some of them, as well as of those reported as unknown, appreciated the after results of the treatment and went on to recovery. Still further, it is in every way probable that some of the failures might, by greater perseverance on the part of the patients, have been transformed into perfect successes.

It is believed that these various errors to a certain extent counterbalance each other, and that on the whole our statistical reports fairly represent, so far as they go, the legitimate results of the electrical treatment. And yet it should be considered that the majority of the cases represented in our statistics were both long-standing and peculiarly obstinate, and there is ground for the belief that those who treat milder and more recent cases by the same methods, will obtain a larger percentage of success.

It will be observed that throughout the work these leading ideas are kept constantly in the foreground as the foundation principles on which must rest the science of electro-therapeutics:—

1. That electrization, besides being merely a local stimulant, also exercises an influence over general and local nutrition, at once unique and unrivalled, and that entitles it to the highest rank among constitutional tonics.

2. That the accepted system of making the applications exclusively local is both illogical and inconsistent; that in the use of electricity, as of every other remedy, constitutional diseases should be treated constitutionally.

3. That the best method of bringing the whole system under the direct influence of the current is by general electrization as here described; and that by the use of this method the success of electro-therapeutics is materially enhanced, and its sphere very greatly widened, so as to include a variety of frequent and distressing constitutional morbid conditions, for which merely localized electrization is but imperfectly indicated.

4. That, in determining the influence of the electrical applications on conditions of disease the last appeal must be made, not to physics nor to physiology, nor to pathology, nor to any *à priori* reasoning whatever, but solely and alone to clinical experience.

To those who adhere to the long-accepted theory that electricity is merely a means for local stimulation, and, as such, chiefly indicated in the severe or incurable conditions of paralysis or chronic rheumatism, or who hope to reduce electro-therapeutics to an exact science on the basis of a complete physiology and pathology, the above propositions must seem both radical and erroneous, and especially so if they have studied the action of electricity on the body merely by localized applications.

Therefore with all the greater interest and pleasure have we observed that, during the last few years, there has been in electro-therapeutical literature a manifest and increasing tendency to abandon the narrow doctrines of merely local stimulation, to accept the fact which experience everywhere confirms, that in electricity we have an unsurpassed means of improving the general nutrition in the immense variety of chronic morbid conditions where such results are chiefly indicated; and we express the confident hope that the abundant and varied evidence with which in the present work we have been enabled to fortify these propositions, increased and enriched as it may be by the experience of the future, and harmonizing as it surely must with the general progress of science, will materially aid in bringing nearer the day of their universal acceptance.

Although this work is not intended to be in any sense a complete guide to the study of chronic diseases of the nervous system, yet some general remarks on the nature, causation, and the diagnosis of the principal of these diseases have been deemed both appropriate and necessary, for the twofold reason that such knowledge is necessary for an intelligent appreciation of the directions for the treatment, and also because very many of the diseases here mentioned—such as nervous dyspepsia, spinal irritation, neurasthenia, hypochondriasis, insomnia, locomotor ataxy, muscular atrophy, spinal and infantile paralysis, as well as some of the varieties of neuralgia—have not received in any one

popular text-book the practical attention which their vast importance in electro-therapeutics requires.

Scientific electro-therapeutics requires scientific diagnosis. He who only knows how to apply electricity is not fit to do even that. Successful results in electro-therapeutics can be and are obtained by the most ignorant of charlatans, but to intelligently report these successes or make them of value to science requires the best skill of the physician. Mere hand-books of electrical applications cannot be otherwise than injurious to science. Other conditions being the same, the value of reports of cases in electro-therapeutics is in direct proportion to the accuracy and completeness of the diagnosis. For this reason it is that electro-therapeutics is the most exacting and laborious of all the special departments, for in a certain sense it trenches on and necessitates a knowledge of all other departments.

In the strict sense of the word, therefore, the electro-therapist is no specialist, since his ideal—which of course he can but imperfectly fulfil—must be to know something of every department with which electro-therapeutics brings him into relation. His ambition, like that of Bacon, must be “to make all knowledge his province.”

Besides a thorough familiarity with the department of nervous diseases, and especially with the recent methods of studying them by the æsthesiometer, the ophthalmoscope, and by electricity, it is necessary for the electro-therapist to avail himself of all the advances that are made in the special departments of gynæcology, ophthalmology, otology, laryngology, and dermatology, as well as general medicine and surgery.

In respect to diagnosis we have ourselves been exceptionally favored, since the majority of our cases have obtained the opinion of one or more acknowledged authorities in their respective departments.

That all the special views on the nature and treatment of the diseases here mentioned should meet with universal acceptance, is more than can be expected. Everywhere we tread on debatable ground. In regard to the nature, the causation, the symptoms, the general treatment, the divisions and the terminology of diseases, the choice of currents, the methods of applications, the relative merits of rival apparatus,—in these and in many other subjects there is room for the widest possible divergence of honest opinion among those whose abilities and opportunities entitle their opinions to the highest respect. On all these controverted themes we present nothing as a finality, nothing which we shall not readily modify in the light of sufficient inductive evidence.





# CONTENTS.

## ELECTRO-PHYSICS.

---

### CHAPTER I.

A KNOWLEDGE OF THE PRINCIPLES OF ELECTRO-PHYSICS NECESSARY TO THE ELECTRO-THERAPEUTIST—DEFINITION OF ELECTRICITY—MAGNETISM. Polarity of magnets—Magnetic induction .....	1-7
--	-----

### CHAPTER II.

FRICTIONAL, OR STATICAL, OR FRANKLINIAN ELECTRICITY. Statical induction—Distribution of electricity—Holtz's machine—Electrophorus—Gold-leaf electroscope—Leyden jar.....	8-18
--	------

### CHAPTER III.

GALVANISM, OR VOLTAIC ELECTRICITY. Chemistry of the battery—Simple galvanic circles—Polarity of the circuit—Electro-chemical series—Amalgamation—Polarity of electricity—Derived of branch currents—Polarization of electrodes—Daniell's and Grove's batteries—Zinc-carbon batteries—Smee's battery—Galvanometers—Volta's researches .....	19-44
--	-------

### CHAPTER IV.

ELECTROLYSIS (ELECTRO-CHEMISTRY). Laws of electrolysis—Theory of electrolysis.....	45-50
--	-------

### CHAPTER V.

INDUCED ELECTRICITY—CURRENT AND MAGNETO-INDUCTION—ELECTRO-MAGNETISM. Thermo-electricity—Ampère's theory of magnetism—Electro-magnetic helix—Induction coils—Ruhmkorff's coil—Magneto-electricity—History of induction—Thermo-electric batteries.....	51-64
--	-------

### CHAPTER VI.

OHM'S LAW AND ITS PRACTICAL APPLICATION TO ELECTRO-THERAPEUTICS. Electro-motive force—Tension or potential—Resistance—Quantity or strength of current—Large cells <i>vs.</i> small cells.....	65-83
---	-------

## ELECTRO-PHYSIOLOGY.

---

### CHAPTER I.

- RELATION OF ELECTRO-PHYSIOLOGY TO ELECTRO-THERAPEUTICS—ANIMAL ELECTRICITY. Electric fishes—Galvani and Volta—Humboldt's and Aldini's researches—Du Bois-Reymond's discoveries—Experiments of Trowbridge. .... 87-98

### CHAPTER II.

- ELECTROTONOS, ANELECTROTONOS, AND CATELECTROTONOS. Du Bois-Reymond's molecular theory of anelectrotonos—Effects of electrotonos—Pflüger's contraction law..... 99-104

### CHAPTER III.

- ACTION OF ELECTRICITY ON THE SKIN. Action of the faradic current—Of the galvanic current—Electro-anæsthesia. .... 105-111

### CHAPTER IV.

- ACTION OF ELECTRICITY ON THE BRAIN AND SPINAL CORD. Galvanization of the brain—Experiments of Hitzig, Ferrier, and others. .... 112-115

### CHAPTER V.

- ACTION OF ELECTRICITY ON THE SYMPATHETIC AND PNEUMOGASTRIC. Experiments with sphygmograph. .... 116-127

### CHAPTER VI.

- ACTION OF ELECTRICITY ON THE NERVES OF SPECIAL SENSE. Action on the optic nerve—On the auditory nerve—Brenner's researches—Action on the gustatory nerve ..... 128-140

### CHAPTER VII.

- ACTION OF ELECTRICITY ON MOTOR AND SENSORY NERVES AND VOLUNTARY MUSCLES. Electro-muscular contractility—and electro-muscular sensibility—Increase of temperature after muscular contraction—Electro-physiological anatomy..... 141-157

### CHAPTER VIII.

- ACTION OF ELECTRICITY ON INVOLUNTARY MUSCLES. Experiments... 158-163

## CHAPTER IX.

ACTION OF ELECTRICITY ON THE BLOOD. Experiments..... 164-167

## CHAPTER X.

ELECTRO-CONDUCTIVITY OF THE HUMAN BODY. Modified by age and temperament..... 168-175

## CHAPTER XI.

THE EFFECT OF ELECTRICITY ON NUTRITION. Mechanical, physical, chemical, and physiological effects—Electrical endosmosis after physical effects—Electrolysis of living substance—Circulation—Secretion—Excretion—Absorption—Effects produced by increase in size and weight—Reflex action—Experiments—Effects of electricity on bacteria and on the growth of plants..... 176-195

## ELECTRO-THERAPEUTICS.

## CHAPTER I.

HISTORY OF ELECTRO-THERAPEUTICS. Era of Franklinic electricity—Era of galvanization—Era of faradization—Localized faradization and galvanization—General faradization—Central galvanization..... 198-215

## CHAPTER II.

GENERAL THERAPEUTICAL ACTION OF ELECTRICITY. Electricity a stimulating sedative tonic—Is electricity transformed into nerve force?—Electricity compared with other tonics—Rationale of electrization..... 217-225

## CHAPTER III.

GENERAL SUGGESTIONS IN REGARD TO THE USE OF ELECTRICITY AS A THERAPEUTIC AGENT. Stage of disease, when indicated—Differential action of poles and of current direction—Both seat of disease and effects to be treated—Healthy parts may be benefited—Dose of electricity—Mild currents—Care in details of application—Time, frequency, and regularity of applications—Combination of methods—How to judge of effects—Good effects—Bad effects—Regard for age—After effects—Use of electricity by the laity—Abbreviations used in electro-therapeutics..... 226-260

## CHAPTER IV.

COMPARATIVE VALUE OF THE GALVANIC AND FARADIC CURRENTS. Advantages of galvanic over faradic—Advantages of faradic over galvanic—Galvano-faradization..... 261-267

## CHAPTER V.

- THE PRINCIPLES OF ELECTRO-DIAGNOSIS (ELECTRO-PATHOLOGY). Modifications of electro-sensibility—Electro-muscular sensibility and contractility—Galvano *vs.* Farado-muscular contractility—Reaction of degeneration—Abnormal reflex irritability—Diplegic contractions—Electro-bioscopy..... 268-282

## CHAPTER VI.

- ELECTRO-THERAPEUTICAL ANATOMY. Motor points—Electro-sensibility of surface of the body..... 283-290

## CHAPTER VII.

- APPARATUS FOR ELECTRO-THERAPEUTICS. Single and separate coil machines—Faradic apparatus—Rules for its use—Galvanic apparatus—Directions for use—Cabinet battery—Rheostats—Galvanometers and electrodes—Care of electrodes—European batteries..... 291-330

## CHAPTER IX.

- LOCALIZED ELECTRIZATION. Dry faradization—Electric moxa—Electrization with moistened electrodes—Direct and indirect electrization—Definition of terms—Details of applications—Electrization of the brain, spine, cervical sympathetic, plexuses, nerves, muscles—Effects..... 331-346

## CHAPTER X.

- GENERAL FARADIZATION. Object proposed—Position of patient—Of operator—Application to head and neck—Use of hand as an electrode—Special rules observed—Persistence in treatment—Effects—Rationale of effects..... 347-371

## CHAPTER XI.

- DIFFERENTIAL INDICATIONS FOR THE USE OF LOCALIZED AND GENERAL FARADIZATION. Cause of failures in electro-therapeutics—Combination of the methods..... 372-375

## CHAPTER XII.

- CENTRAL GALVANIZATION. Method—Details of the application—Theory of the method—Compared with localized galvanization—With general faradization—Objections answered..... 376-389

## CHAPTER XIII.

- THE USE OF FRANKLINIC OR STATIC ELECTRICITY. Apparatus for franklinization—Methods of application—Value of franklinic electricity as compared with dynamic electricity..... 390-394

## CHAPTER XIV.

- ELECTRIC BATHS. Method of giving—Effects—Rules for giving them.. 395-398

## CHAPTER XV.

**HYSTERIA AND ALLIED AFFECTIONS.** Electro-diagnosis—Cases of hysteria—Hypochondriasis—Cases—Neurasthenia—Spinal irritation—Insomnia—Astraphobia (fear of lightning)..... 399-415

## CHAPTER XVI.

**INSANITY.** Methods used—Cases..... 416-420

## CHAPTER XVII.

**CEREBRAL AND SPINAL CONGESTION.** Prognosis and treatment—Cases.. 421-424

## CHAPTER XVIII.

**NEURALGIA.** Methods of treatment—General prognosis—Cephalalgia—Cases—Sick headache (migraine)—Facial neuralgia—Gastralgia—Sciatica—Reflex neuralgia—Galvanic belts and disks..... 425-446

## CHAPTER XIX.

**ANÆSTHESIA.** Different kinds of sensibility—Farado-sensibility—Electro-diagnosis—Prognosis—Cases ..... 447-451

## CHAPTER XX.

**PARALYSIS.** Paralysis from opium—Syphilitic paralysis—Lead paralysis—Hysterical paralysis—Cases—Hemiplegia, treatment and accessories—Cases of hemiplegia—Glosso-laryngeal paralysis—Paraplegia—Facial paralysis—Paralysis from pressure and cold—Reflex paralysis..... 452-473

## CHAPTER XXI.

**LOCOMOTOR ATAXIA (POSTERIOR SPINAL SCLEROSIS).** Causes of the disease—Electro-diagnosis—Prognosis—Treatment—Cases..... 474-477

## CHAPTER XXII.

**PROGRESSIVE MUSCULAR ATROPHY.** Prognosis and treatment—Cases—Progressive myo-sclerotic (Pseudo-hypertrophic paralysis)..... 478-482

## CHAPTER XXIII.

**RHEUMATISM AND GOUT.** Treatment—Prognosis—Cases—Myalgia—Lumbago—Pleurodynia—Rheumatic gout ..... 483-489

## CHAPTER XXIV.

**SPASMODIC DISEASES.** Writer's cramp—Torticollis—Cases—Paralysis Agitans—Asthma—Facial spasm—Hydrophobia—Epilepsy—Cases... 490-501

## CHAPTER XXV.

**DISEASES OF THE SKIN.** General considerations—Methods of application—Central galvanization—Eczema—Prurigo—Lichen—Anæsthesia—Acne—Acne rosacea—Psoriasis pityriasis—Herpes—Herpes frontalis—Ringworm—Scleroderma—Melanoderma—Elephantiasis—Case—Alopecia—Permanence of results..... 502-516

## CHAPTER XXVI.

- DISEASES OF THE ORGANS OF DIGESTION. Electro-diagnosis—General principles of treatment—Dyspepsia—Cases—Constipation—Chronic diarrhoea—Jaundice—Ileus (invagination)—Regurgitation (vomiting)—Flatulence—Sea-sickness. . . . . 517-528

## CHAPTER XXVII.

- DISEASES OF WOMEN. Amenorrhœa—Dysmenorrhœa—Menorrhagia—Leucorrhœa—Methods of treatment, external and internal—General and central treatment—Franklinization—Prognosis—Cases—Atrophy and displacement of the uterus—Congestion and enlargement—Irritation and congestion of ovaries—Intra-uterine galvanic pessaries . . . . . 529-544

## CHAPTER XXVIII.

- DISEASES OF CHILDREN. Chorea—Marasmus and Whooping-cough—Incontinence of urine—Vomiting and cholera infantum—Paralysis—Microscopic examination of muscles—Treatment—Cases. . . . . 545-557

## CHAPTER XXIX.

- DISEASES OF THE GENITO-URINARY ORGANS. Electro-diagnosis and treatment of impotence—Aspermatism—Spermatorrhœa—Cases—Paresis and paralysis of the bladder—Orchitis—Enlargement of the prostate—Prolapsus ani—Prolapsus of the sphincter—Hemorrhoids. . . . . 559-570

## CHAPTER XXX.

- DISEASES OF THE LARYNX. Anæmia—Aphonia—Treatment—Cases—Spasmus glottidis—Nervous cough—Hyperæsthesia—Anæsthesia. . . . . 571-580

## CHAPTER XXXI.

- DISEASES OF THE EYE. General considerations—Paresis and paralysis of muscles—Astenopia—Amblyopia and amaurosis—Spasm of the lid—Opacities of cornea and vitreous humor—Ptosis and mydriasis—Myosis—Neuro-retinitis—Strabismus. . . . . 581-589

## CHAPTER XXXII.

- DISEASES OF THE EAR. General considerations and methods of application—Pathological reactions—General results—Subacute and chronic inflammation of middle ear—Tinnitus aurium—Hysterical deafness—Chronic suppuration of the middle ear. . . . . 590-602

## CHAPTER XXXIII.

- MIDWIFERY. Faradization for inertia uteri—Post-partum hemorrhage—Deficient lacteal secretion—Sore nipples—Extra-uterine pregnancy. . . . . 603-611d

## CHAPTER XXXIV.

ARTIFICIAL RESPIRATION BY ELECTRIZATION IN CASES OF APPARENT DEATH FROM DROWNING, OR SUFFOCATION THROUGH POISONOUS GASES, OR IN ASPHYXIA OF NEW-BORN INFANTS..... 612-614

## CHAPTER XXXV.

DISEASES OF THE HEART AND LUNGS. Palpitation of the heart—Angina pectoris—Consumption..... 615-619

## CHAPTER XXXVI.

EXOPHTHALMIC GOITRE. Methods of treatment—Cases..... 620-627

## CHAPTER XXXVII.

SEQUELÆ OF ACUTE DISEASES. Diphtheria—Cerebro-spinal meningitis—Typho-malarial fever—Sunstroke..... 628-635

## CHAPTER XXXVIII.

MISCELLANEOUS MEDICAL DISEASES. Cases—Intermittent fever—Addison's disease—Case—Diabetes—Dropsical effusions—Bright's disease—Suppression of urine—Diabetes—Chronic rhinitis—Catarrh of nose—Anosmia—Toothache—Ozone and ozonized oxygen—Hay fever—Fever and convalescence—Obesity—Cirrhosis of the liver—Chronic alcoholism..... 636-651

## ELECTRO-SURGERY.

## CHAPTER I.

HISTORY OF ELECTRO-SURGERY. Early history—Later history—Surgical and medical electricity compared..... 655-660

## CHAPTER II.

ELECTROLYSIS. Its nature and general methods—Method of introducing the needles—Electrolyzing the base—Method of operating—Instruments—Theory of the method—Its advantages and disadvantages..... 661-672

## CHAPTER III.

GALVANO-CAUTERY. Advantages over actual cautery—Apparatus, handles, burners, loops for Galvano-cautery—Care of batteries—Uses and advantages of the galvano-cautery—Rules for use of galvano-cautery, and adaptation to various departments—Statistics of cases..... 673-685

## CHAPTER IV.

BENIGN AND MALIGNANT TUMORS. Nævi (erectile tumors)—Goitres— Benign cystic tumors—Malignant cystic tumors—Hydatids of the liver —Fibroids—Fibroids of uterus—Lipomata (fatty) tumors—Adenitis— Ovarian tumors—Polypi—Epithelioma—Scirrhus and other malignant growths—Cases—Relief of pain of cancer by galvanization—Illustrative cases.....	686-715
--	---------

## CHAPTER V.

ANEURISMS AND VARICOSE VEINS. Method of operating—Statistics of aneurisms treated by electricity—Varicose veins.....	716-720
---	---------

## CHAPTER VI.

STRICTURES. Stricture of the urethra—Experiments and cases—Stricture of the œsophagus.....	721-725
---	---------

## CHAPTER VII.

ULCERS, FISTULÆ AND SINUSES. Ulcers—Bed-sores—Method of treat- ment—Galvano-ozonization.....	726-728
---	---------

## CHAPTER VIII.

MISCELLANEOUS SURGICAL DISEASES. Stumps after amputation—Hæ- matocele—Gangrene—Carbuncles—Furuncles—Burns—Frost-bite (chilblains)—Synovitis—Hydrocele—Sprains—Strains of muscles— Spondylitis (Pott's disease)—Spinal curvature—Pseudo-arthritis (un- united fracture)—Hernia—Morbus coxarius (disease of the hip-joint)— Club-foot (talipes)—Warts—Dissolution of calculi in the bladder— Electric explorer or probe—Extraction of foreign bodies by the electro- magnet—Electro-chemical baths—Removal of poisonous metals from the body—Faradic anæsthesia—Hydro-electrization—Electro-medica- tion—Podalgia.....	729-741
---	---------



## LIST OF ILLUSTRATIONS.

---

	PAGE
1—Magnetic Zone, illustrated.....	3
2— “ Polarity, illustrated.....	4
3— “ Armature.....	6
4—Insulated Conductor.....	10
5—Brass Hemispheres.....	11
6—Insulated Cylinder.....	12
7—Cylinder Electrical Machine.....	13
8—Holtz's Machine.....	14
9—Bennett's Electroscope.....	15
10—Leyden Jar.....	16
11—Simple Galvanic Circle.....	22
12—Compound Galvanic Circle.....	28
13—Branch Current, illustrated.....	29
14—Voltaic Pile.....	30
15—Daniell's Battery.....	32
16—Grove's Battery.....	34
17—Bunsen's Nitric-Acid Battery.....	34
18—Smee's Battery.....	37
19—Voltmeter.....	40
20—Astatic Galvanometer.....	41
21—Galvanic Frog.....	43
22—Phenomena of Electrolysis.....	50
23—Electro-magnetic Helix.....	53
24—Electro-magnet.....	53
25—Current Induction, illustrated.....	54
26—Induction, illustrated.....	55
27—Current-interrupter.....	56
28—Ruhmkorff's Coil.....	58
29—Horse-shoe Magnet.....	61

	PAGE
30—Thermo-electricity, illustrated.....	63
31—Farmer's Thermo-electric Battery.....	64
32—Electrotonos, illustrated.....	100
33—Anelectrotonos and Catelectrotonos, illustrated.....	101
34-43—Sphygmographic Tracings.....	125
44—Electro-therapeutical Anatomy of the Human Body— anterior view.....	286
45—Electro-therapeutical Anatomy of the Human Body— posterior view.....	287
46—Kidder's Faradic Machine.....	295
47—Faradic Machine (Galvano-Faradic Manufacturing Co.).....	299
48— “ “ without the box.....	300
49— “ “ (Thomas Hall).....	301
50—Zinc-carbon Battery, 32 cells.....	303
51—Bartlett Battery.....	304
52—Galvanic Battery, 36 cells.....	305
53—Kidder's Zinc-carbon Battery, 18 cells.....	306
54—Chloride of Silver Battery.....	308
55—Cabinet Battery (Galvano-Faradic Manufacturing Co.).....	309
56—Portable Galvanic Battery (Drescher).....	313
57—Galvano-Faradic Machine, “.....	314
58—Portable Beetz-Leclanché Battery.....	315
59—Brenner's Apparatus (Galvano-Faradic Manufacturing Co.).....	316
60—Galvanometer used by the Authors (Chester & Co.).....	316
61—Siemen's Stopper-rheostat.....	317
62—Hydro-rheostat (Galvano-Faradic Manufacturing Co.).....	318
63—Universal Handles for Electrodes.....	319
64— “ “ “ “ with Interrupter, insulated.....	319
65—Long Sponge Electrode.....	320
66—Electrodes of various sizes to be attached to Universal Handles.....	320
67—Hard Rubber Handle and Electrode.....	320
68—Sponge-holder, with sponge attached.....	320
69—Small Sponge Electrode.....	320
70—Duchenne's Electrode.....	320
71—Rockwell's Brass Ball Electrode for General Faradization.....	320
72—Beard's Stationary Electrode.....	321
73—Adjustable Electrode, with band.....	321
74—Beard's Adjustable Electrode, with flannel cover.....	322
75—Flannel Cover for Electrode.....	322
76—Adjustable Electrode, with sponge.....	323
77—Oblong Adjustable Electrode.....	323

	PAGE
78—Metallic Brush.....	323
79— “ “ with brush pushed within the cylinder.....	323
80—Spinal Electrode.....	323
81—Beard's Current-reverser.....	324
82—Meyer & Meltzer's Faradic Machine.....	327
83—Foveaux's Portable Galvanic Battery.....	329
84—Meyer & Meltzer's Portable Apparatus.....	330
85—Galvanization of the Cervical Sympathetic.....	336
86— “ “ “ “ including the Pneumogastric ..	337
87—Faradization of Facial Nerve and Muscles.....	339
88—Muscular Faradization, with Metallic Electrodes.....	339
89—Faradization of muscles of thigh.....	340
90— “ “ Popliteal Nerve and Peroneal Muscles.....	340
91—Spinal-cord-brachial plexus current.....	342
92—Spinal-cord-medium nerve current.....	342
93—General Faradization, application to head.....	349
94— “ “ “ “ spine.....	351
95—General Galvano-faradization, application to spine by sponge-holder.....	354
96—General Faradization, application to stomach.....	358
97— “ “ “ “ lower extremities.....	359
98—Central Galvanization, first stage.....	376
99— “ “ second stage.....	377
100— “ “ third stage.....	378
101— “ “ fourth stage.....	379
102—Method of Franklinization.....	394
103—Electric Bath.....	396
104—Circle Disk.....	486
105—Oblong Button Disk.....	486
106—Elephantiasis of legs, before treatment by electricity.....	515
107—Rectal Electrode, non-insulated.....	523
108— “ “ insulated.....	523
109—Double Rectal Electrode.....	523
110—Faradization of the Uterus.....	530
111—Uterine Electrode.....	531
112—Beard's Intra-uterine Electrode.....	531
113—Double Intra-uterine Electrode.....	531
114—Duchenne's Double-uterine Electrode, open.....	532
115— “ “ “ “ closed.....	532
116—Vaginal Electrode.....	533

	PAGE
117—Intra-uterine Galvanic Pessary.....	543
118—Duchenne's Trocar.....	552
119—Noeggerath's Trocar.....	552
120-121-122—Normal Fibre, first degree.....	554
123-124—Normal Fibre, second degree.....	554
125-126— “ “ third degree.....	554
127-128-129—Normal Fibre, fourth degree.....	554
130—Insulated Catheter Electrode.....	563
131-132—Double Vesical Electrode, closed and open.....	567
133—Laryngeal Electrode and Necklet.....	574
134—Internal Electrization of Ear.....	591
135—Murray's Galvanic Nipple-shield.....	605
136—Extra-Uterine Pregnancy.....	607
137—Extra-Uterine Pregnancy.....	610
138—Nasal Electrode.....	646
139—Conductor for Electrolysis.....	664
140—Bayonet-pointed Needles for Electrolysis.....	665
141—Rockwell's Long Needle for Electrolysis of Uterus.....	665
142—Rockwell's Needle-Holders with Needles for Electrolysis.....	666
143—Beard's Long-cutting Needles for Electrolysis of the base.....	666
144—Electrolysis of Base in scirrhus of breast.....	668
145— “ “ “ “ “ “ “ “ after removal of tumor.....	669
146—Byrnes' Multiple-element Battery.....	674
147—Zinc-Carbon Galvano-cautery Battery (Kidder).....	675
148— “ “ “ “ “ “ (Galvano-Faradic Manufing Co.).....	675
149— “ “ “ “ “ “ “ “ “ “ “ “.....	676
150—Galvano-cautery Battery (Meyer & Meltzer, London).....	677
151-176—Accompanying Appliances—Handles, Burners, or Cauterizers, Loops, Knives, etc., for Galvano-cautery.....	678-679
177-188— } Galvano-cautery Operating Case and Loop (Galvano-Faradic Man- } ufacturing Co.).....	680
189—Benign Cystic Tumor treated by Ordinary Electrolysis.....	694
190—Electrolysis of Base of Malignant Cystic Tumor.....	697
191—Removal of Epithelioma by Electrolysis of Base.....	702
192— } Epithelioma of Vagina and Vulva before and after operations by Elec- 193— } trolysis.....	705
194—Scirrhus of Breast treated by Ordinary Electrolysis.....	709
195—Trouve's Electric Explorer.....	735
196—Gruening's Magnet.....	737

# ELECTRO-PHYSICS.



# ELECTRO-PHYSICS.

---

## CHAPTER I.

### A KNOWLEDGE OF THE PRINCIPLES OF ELECTRO-PHYSICS NECESSARY TO THE ELECTRO-THERAPEUTIST—DEFINITION OF ELECTRICITY—MAGNETISM.

*Electro-physics is the science which treats of electricity in its physical relations.*

No one can be a master in electro-therapeutics without also being a master in electro-physics. Hence it becomes necessary, in a systematic treatise on electro-therapeutics, to present the leading principles of electro-physics, and to point out their practical bearings both on electro-physiology and electro-therapeutics. This necessity is all the greater because electro-physics is the branch of electrology that electro-therapeutists are most of all disposed to neglect; and ignorance of this department has retarded, and still retards, the scientific advance of electro-therapeutics both medical and surgical. It is possible to make happy hits in electro-therapeutics without knowing anything of electro-physics or electro-physiology; but on the average, and in the long run, the best results will be obtained by those who to purely practical knowledge add a thorough mastery of the scientific relations of the subject.

*Why discussed in a Practical Treatise like this.*—The necessity of presenting the leading principles of electro-physics in a practical treatise like this is the more imperative from the fact that, until quite recently at least, all, or nearly all, the text-books on physics in use in schools and colleges have failed to represent the advanced researches and generalizations of modern scientists in the department of electricity. The old hypotheses, that electricity is a single or double fluid, still linger in our centres of education, or yield the ground but slowly; and even in those works that are fully up to the times on this subject, the special

and practical bearings of electro-physical principles on electro-physiology and electro-therapeutics are of course not considered.

To this should be added the consideration that any science, however well acquired, if it be not kept before the mind by teaching or writing, or by practical application, soon fades from the memory, or becomes a mass of half-truths and uncertainties. We are therefore justified in assuming that not one in a hundred of those who will consult this book as a guide in electro-therapeutics will be so thoroughly and accurately informed on the principles of electro-physics as not to need, on this subject, some compact treatise which shall serve as a guide and reminder of the leading facts and principles of the science. To supply this need is the object of this division of our treatise.

#### NATURE AND DEFINITION OF ELECTRICITY.

*Electricity is now regarded as a FORCE correlated to the other great forces of nature—heat, light, etc.—and, like them, is simply a mode of motion,—a form of vibration.*

Although the precise nature of these vibrations have not yet been mathematically demonstrated, as in the case of light and heat, yet the theory that the phenomena of electricity are the result of vibrations has much in its favor, and it is by no means impossible that in the future the nature of these vibrations will be well understood.

In the present treatise, as in all works on physics, various terms, as "current," "flows," "runs," etc., that took their origin when the fluid theory prevailed, are retained for the sake of convenience of description. With this understanding there is no objection to their use.

Electricity is manifested in three general forms: *Magnetism*; *Statical or Frictional* or *Franklinic* Electricity; and *Galvanism*, or *Voltaic* or *Dynamical* Electricity.

#### MAGNETISM.

*Magnetism.*—In order to understand electricity in general it is necessary to understand magnetism, which is one of its manifestations. Magnetism, defined by its phenomena, is the power *which certain bodies possess* of attracting iron. The bodies which are observed to have this power are called *magnets*, and are divided into two classes—*natural* and *artificial*. Natural magnets consist of iron ore or loadstone. Load-



stone was first discovered in Magnesia, in Asia Minor, and hence the name *magnet* was derived. The compass was introduced into Europe in the twelfth century; but the Chinese are said to have been acquainted with it in the fourth century.

*Artificial magnets* are usually made of steel that has been magnetized by the galvanic current or by other magnets. Steel bars that have been thus magnetized may be either straight or bent. For convenience' sake, they are usually bent in the form of a horseshoe.

All substances are more or less susceptible to magnetic influence, but iron is more affected by it than others. Experiments illustrative of the effects and power of artificial magnets are so familiar that they need not be cited.

*Polarity of Magnets.*—The *polarity* of a magnet is that peculiar property by which it manifests two *opposite* kinds of magnetism, that are termed, relatively to each other, the north and the south pole. When a magnetic needle is so suspended that it can move unimpeded in any direction, one end points to the north, and the other to the south. If the magnet be disturbed in any way, and forced temporarily out of position, it at once and uniformly returns.

Polarity is a quality that belongs not only to magnetism, but also to other forms of electricity, and to light and the other great forces.

The poles of a magnet are always at its ends, for here the attractive power is greatest. This can be demonstrated by a very simple experiment. If a magnetic bar be rolled in a pile of iron-filings, it will be found that these adhere to the bar most firmly and in the greatest quantity at and near its poles. The quantity that adheres is less as we approach the middle of the bar.

*Neutral Line.*—In long bars there is always a place at the middle, or near to it, where no filings are attracted. This space is variously termed the *neutral* or *magnetic zone*, or *magnetic equator*, or *point of indifference*.

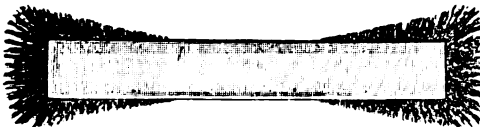

FIG. 1.

Another familiar experiment is to pass an iron ball, suspended by a string or thread, near to a magnet from end to end. It is observed that the ball is attracted very little, or not at all, in the middle, but

that the attractive power is increased as we bring it towards either end. If any substance be placed between the ball and the magnet, the attraction is just as marked, unless the interposed substance itself contains iron. Nearly all substances that are not themselves magnetic are capable of transmitting the magnetic influence.

Another feature of magnetic polarity is, that like poles repel, and unlike poles attract, each other. If one magnetic bar be suspended freely in the air, and another be brought near to it, it will be found that the north pole of one is attracted by the south pole of the other, and *vice versa*—in short, that the like poles repel, while the unlike attract.

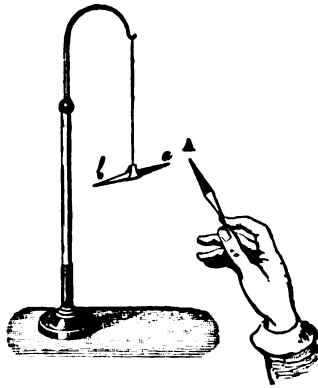

FIG. 2.

*Magnetism of Broken Magnets.*—If a bar that has been magnetized be broken in the middle, each half will have two poles and a neutral point in the centre. If one of these halves is broken in the middle, each half will be found to have two poles and a neutral line. If one of these parts in turn be broken, each half will again be found to be a complete magnet, with two poles and a neutral line, and so on as long as we can carry the division.

*Coulomb's Theory of Magnetism.*—A theory of magnetism advanced by Coulomb is, that magnetic substances consist of *particles, each one of which is a magnet*. These particles have their poles turned in different directions, so as to neutralize each other.

Magnetization brings these particles round so that *they lie in the same direction*. This theory brings magnetism very close to statical electricity, and would naturally be adopted by those who believe all magnetic *phenomena* result from electricity *in magnetic bodies*.

Between the behavior of electricity in animal bodies (animal electricity), electricity in general (statical and dynamical electricity), to be subsequently explained, and magnetism as here explained, there are analogies so close and so consistent as to warrant the view that all are but *different manifestations of one force*.

*Magnetic Induction.*—If a bar of soft iron is brought in contact with or near to one of the poles of a magnet, it is attracted, and for the time being becomes itself magnetic; and if it is brought near enough to the magnet, it firmly adheres to it. A bar of soft iron thus obtains by *induction* all the properties of an ordinary magnet. It has a north and south pole. It attracts iron-filings around these poles, just like the regular magnet. If another piece of soft iron is brought in contact with, or near to its poles, it is attracted and made to adhere, just as it would do if applied to an ordinary magnet. Quite a number of bars of soft iron may be made to adhere in the same way. But when this bar, thus made magnetic, is forcibly removed from the permanent magnet to which it adheres, it instantaneously loses all its magnetic power, and the iron-filings or pieces of soft iron that have been attracted by it at once drop off. Such a magnet is therefore styled "*temporary*," in contradistinction to the *permanent* magnets of steel.

If a bar of *steel* is brought near to, or in contact with a magnet, it also becomes magnetic, and exhibits very different phenomena from the bar of soft iron. In the first place, it becomes magnetic much more slowly than the bar of soft iron, and displays less magnetic power. On the other hand, it does not, like the soft iron bar, lose its attractive power as soon as it is removed from the magnet, but *permanently* retains it.

The quality of steel by which it at first resists the attractive power of magnets, and resists the dispersion of the magnetism which it has once acquired, is called *coercitive force*.

The same phenomena are observed in regard to heat. Some bodies that are quick to acquire heat, are quick to part with it; and *vice versa*, those bodies which, like iron, steel, and so forth, acquire heat gradually, also part with it slowly.

It is by virtue of its coercitive force that *loadstone* permanently retains its magnetism.

The harder any steel is, the greater its coercitive force. Steel that is soft has comparatively little coercitiveness, and when brought near to, or in contact with a magnet, it behaves very much like soft iron. Very hard steel, on the contrary, has so great coercitiveness that it is only attracted by very powerful magnets.

Soft iron, when adulterated with sulphur, phosphorus, arsenic, or charcoal, or if it is even twisted or bent, may exhibit a slight degree of coercitive force. Soft iron that is perfectly pure possesses no coercitive force whatever.

The law of the distribution of magnetism in a bar of iron, and the law of magnetic attraction and repulsion were discovered by Coulomb in 1789.

*Shape of Magnets—Magnetic Armatures.*—Artificial magnets are either composed of straight bars, or are bent in the shape of a horse-shoe. The horseshoe form is used mainly for the sake of convenience. It enables us to apply both poles simultaneously and uniformly to the object that is to be magnetized. Very powerful magnets may be made of a number of thin steel bars placed side by side, their poles being situated homonymously, that is, lying in the same direction. A number of bundles of bars of steel arranged in this way is called a "*magnetic magazine, or battery.*"

*Magnetic armatures* are pieces of soft iron that are placed at the ends of magnets, to keep their magnetic power. This bar, or armature, not only receives magnetism from the magnet, but acts upon it in return, and thus helps to preserve its magnetic power. Magnets that are not provided with an armature gradually lose their attractive power by the disturbing influence of the magnetism of the earth. The magnetic power of magnets is apt to be impaired by letting them fall on a hard surface, or by suddenly striking them with a solid body.

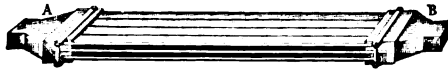

FIG. 3.

*Magnetization.*—It is possible to communicate magnetism to bodies that can retain it in several different ways:

1. *By single Touch.*—The bar which we wish to magnetize is laid on a table, and the pole of a magnet is rubbed along its surface from end to end for a number of times.

2. *By double Touch.*—The bar that is to be magnetized is placed on a piece of wood, the ends of which are placed against two strong magnets. Two magnets for rubbing are placed on the bar to be magnetized, making an angle with the bar of from  $15^\circ$  to  $20^\circ$ . A small piece of wood is placed between the extremities of these two magnets, to prevent their touching. They are then rubbed along the bar that is to be magnetized, from the middle towards the end, and back again, and

raised from the magnetized bar again at the middle. This method communicates a strong, though sometimes irregular magnetism; it was invented by Mitchell, and perfected by Epinus in 1758.

3. *By separate Touch.*—This method consists in putting two opposite poles of two magnets of the same force in the middle of the bar that is to be magnetized, and moving each of them at the same time toward the opposite end of the bar. This operation is repeated several times on both sides until the bar is magnetized.

The magnets may be held vertically or may be inclined.

The vertical method was first used by Knight in 1745.

4. *By the Galvanic Current.*—The bar to be magnetized is placed inside a coil of insulated wire through which a galvanic current is running, and is then moved backward and forward, as in the method by the double touch.

5. *By the Earth.*—It is clear that the earth is itself a magnet, for it manifests strong inductive power. A steel rod becomes permanently magnetic when it is held parallel to a dipping-needle. If a bar of soft iron is held in the same position it also becomes magnetic, and much more rapidly than the steel bar, but does not so long retain its magnetism. If a soft iron bar, held in this position, is struck a few times by a hammer, its magnetism, which was before temporary, becomes permanent. The blows of the hammer seem to impart in some mysterious way a coercitive force to the temporary magnet.

Large masses of iron, when kept in a stationary position for any length of time, always give proofs of having been magnetized by the earth. Tools in workshops are apt to become permanently magnetic from the repeated hammering to which they are subjected. The magnetism of the loadstone is due to the silent but continuous inductive action of the earth.\*

*Saturation Point of Magnetism.*—The limit of the amount of magnetism that a magnet can permanently retain is called the *point of saturation*. If any magnet receives more of magnetism than it can permanently retain, it gradually loses it or throws it off until it falls to the point of saturation, when it ceases to lose any more. The saturative point of any magnet depends on its temper and coercitive force.

Magnetism is very markedly influenced by temperature. When a magnet is heated it loses its magnetic power in proportion as its temperature rises; when it cools it regains more or less of what it has lost.

\* On this subject we may refer to the able pamphlet of Prof. Mayer on *The Earth a great Magnet*.

## CHAPTER II.

### FRICIONAL, OR STATICAL, OR FRANKLINIC ELECTRICITY.

WHEN glass is rubbed with silk it acquires the power of *attracting* any light substance, such as a pith-ball. By a short contact this property is also communicated to the pith-ball, and it then *repels* the glass instead of being attracted.

These phenomena are explained by the existence of a force which is termed *Electricity*. That which exists in the glass is called *vitreous*, or *positive*, or + electricity. If a piece of sealing-wax be rubbed with flannel it will *attract* the pith-ball, which is *repelled* by the glass. This phenomenon is due to the existence of *resinous*, or *negative*, or — electricity in the sealing-wax.

The name electricity is derived from the Greek word ἤλεκτρον, meaning *amber*, because, as the story goes, Thales of Miletus, one of the seven sages of Greece, first discovered the manifestations of this mysterious force by rubbing a piece of amber with a dry cloth.

The science of electricity dates from 1600, when Dr. Gilbert, of Colchester, physician to Queen Elizabeth, published a work on magnetism, entitled *Tractatus de Magnete*. He first used the word *electricity*. He showed that not only amber, but other bodies, as sulphur, wax, etc., develop electricity. He first used the term poles in magnetism, and announced the first theory of terrestrial magnetism. Not only sealing-wax and glass, but all bodies contain more or less of electricity that may be thus developed by some kind of friction.

~ *Conductors and Non-conductors*.—All bodies are electrically divided into three classes: *Conductors*, *semi-conductors*, and *non-conductors*. Under the first class—conductors—are included water and all saline solutions, the metals, the earths and stones, the structures of plants and animals, etc., etc. Under the second class—semi-conductors—are included ether, alcohol, dry wood, marble, paper, straw, etc., at 32° F. Under the third class—non-conductors, or insulators—are included glass, sealing-wax, porcelain, resins, sulphur, wax, dry metallic oxides, fatty oils, etc., at — 13° F.; phosphorus, india-rubber, gutta-percha, col

Iodion, wool, dry hair, silk, shellac, ebonite, amber, feathers, chalk, lime, dry gases, and aqueous vapor in a dry state.

The conducting power of metals may be lessened by heating them. In nearly all other substances heat increases the conducting power. Certain substances, such as feathers, wool, hair, and the atmosphere, which in a dry state are non-conductors, become, when thoroughly moistened, the best of conductors.

In this classification of all substances into conductors, semi-conductors, and non-conductors, reference is had only to frictional electricity. Substances that are semi-conductors for frictional electricity are non-conductors for galvanic electricity.

Frictional electricity may be obtained not only by rubbing, but also by *cleavage* and *pressure*. When a piece of mica is cleaved, the two plates which are separated exhibit opposite electricities, and a faint light is observed when the cleavage is made in the dark. The light that is seen when sugar-candy or loaf-sugar is broken, is accounted for by the development of electricity through cleavage.

When a thin piece of cork is pressed against a slice of orange, by insulating handles, one assumes a positive and the other a negative electricity. The same phenomena may be obtained by cleavage and pressure of very many other substances, and under diverse conditions.

A conductor is said to be insulated when it is placed on some non-conducting substance, so that the electricity communicated to it is prevented from passing into the ground. Glass is one of the best non-conductors, and is the insulating material usually employed in the construction of electrical apparatus. It is hard, durable, and easily obtained, and, could its surface be kept always dry, would be surpassed as an insulator by no material. In frosty and dry weather it acts very well; but when the atmosphere is at all damp, it becomes coated with a layer of moisture, which very much impairs its insulating power.

A much superior insulator to glass is ebonite, a preparation of vulcanized india-rubber, that of late has been much used.

*Discovery of Electric Conduction.*—Electric conduction was discovered by Stephen Grey in 1729. He found that when a wire 700 feet long, and hung on loops of silk, was connected at one end with a glass tube, and the tube was rubbed, the other end of the wire was electrified and attracted light bodies. When wire-loops were substituted for the silk-loops, the electricity passed off through the wire. Hence originated the distinction between *insulators* and *conductors*.

*Loss of Electricity.*—All electrified bodies lose electricity more or less,

however carefully they may be insulated. There are two reasons for this :—

First. No insulators are perfect. The best insulators, as glass and rubber, conduct somewhat.

Secondly. The air is a conductor ; its conductive capacity depends upon the amount of moisture in it.

In *vacuo*, also, electrified bodies lose their electricity more rapidly than in air, on account of the diminution of the pressure on the insulating surface.

The human body, as will be shown under Electro-physiology, is charged with electricity, which is conducted away by the air, and not unlikely by other conductors.

*Static Induction.*—An insulated conductor, when charged with either positive or negative electricity, acts on bodies placed near to it just as the magnet acts on soft iron ; it attracts the opposite and repels the same kind of electricity. This may be shown in the following manner : A brass cylinder (Fig. 4), rounded at either extremity, is insulated by means of a glass rod.

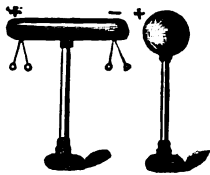

FIG. 4.

Two pith-balls are suspended by cotton thread from each end. If an insulated ball charged with positive electricity be brought in close proximity to the brass cylinder, the pith-balls will diverge, showing a disturbance of the electrical equilibrium in the cylinder. So soon as the charged ball is withdrawn, the pith-balls hang down as before, showing that the electrical disturbance in the cylinder depended on the presence of the charged ball, and was merely temporary.

If a small disk of insulated gilt paper be brought in contact with the end of the cylinder next the charged ball, and then approached toward an electrometer, the needle will indicate that the disk has received — electricity.

If the experiment be tried with the opposite end, + electricity will be transmitted to the gilt disk.

It is thus seen that + electricity of the charged ball causes the near end of the cylinder to assume a — condition ; while, according to a universal law, that no — electricity can be excited without an equal amount of positive electricity, the opposite extremity becomes +. The phenomenon thus described is called *induction*, or influence ; and while in this peculiar electrical condition the cylinder is said to be *polarized*.

*Induction and Conduction compared.*—We have seen that a body may



be charged with electricity both by *conduction*—actual contact—and by induction at a distance. In conduction, the first body loses a part of its electricity; in induction it does not. In conduction, the electricity given to the body is the same as that which gives it; in induction, it is of the opposite kind. In order to impart electricity by conduction, the body must be insulated; to impart electricity by induction, the body must be for the time in connection with the earth. *Bad* conductors are acted on by induction *slowly*, but retain their electricity longer; just as steel which is slowly magnetized becomes a *permanent* magnet, while soft iron, which is rapidly magnetized, soon loses its magnetism. There is a limit to the conductive capacity of every electrified body; when this limit is reached, it ceases to have any effect on the second body.

*Distribution of Electricity.*—It is evident that the greater the surface over which electricity is diffused, the less is its power or intensity at any given point.

*Electricity does not penetrate to the interior of metallic conductors, but diffuses itself over the surface.*

Experiment proves this. Let a brass ball be charged with electricity,

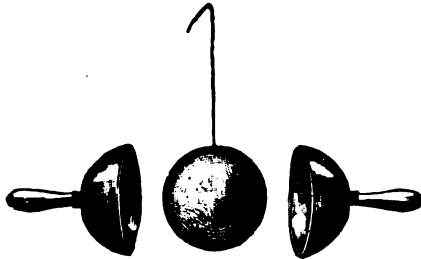

FIG. 5.

and suspended by a silk thread, and then covered with two hemispherical surfaces of brass, which exactly fit it. When the hemispheres are withdrawn, it will be found that they are charged with electricity, which has been entirely taken from the brass ball.

Faraday illustrated this truth by a beautiful and original experiment with a conical bag of cotton gauze, around the opening of which an insulated ring was attached. The bag was held distended by means of a silk thread attached to the apex, and then charged. By the proof-plane, he found that the charge was wholly on the outside. The bag was then turned inside out by pulling the thread the other way, when it was

found that the electricity had changed sides, and lay *wholly* on the outside.

*Density.*—*The quantity of electricity on a given surface at any moment is called electric density, or thickness.*

The shape of a body has an influence in the distribution of electricity over it.

In an ellipsoid, for example, the density is greatest at the small end and least at the middle space.

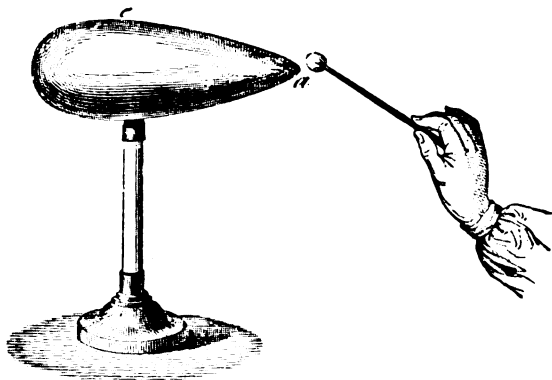

FIG. 6.

On an insulated cylinder, with the two hemispheres at the ends, the density of the electricity is greatest at the ends. On a circular disk, the density is greatest at the edges. *The tendency is for electricity to accumulate at points.* On a sphere the density is uniform; the further removed a body is from a sphere the more irregular the distribution.

In all pointed rods the electricity accumulates at the pointed extremities; hence lightning-rods are made to terminate at sharp points. In electro-physiology and electro-therapeutics it is found that small, pointed electrodes cause much more pain, the strength of the current being the same, than large, broad electrodes. Hence, except in those cases where it is desired to confine the action of the current to a very limited surface, electrodes of pretty good surface are desirable.

*Electric Machines.*—This term is exceedingly vague. It is applied to any and all forms of electrical apparatus. The first electric machine was made in 1672, by Otto von Guericke, of Magdeburg.\* It consisted of a globe of sulphur, turned on its axis by one hand and pressed against

\* *Experimenta Nova. Magdeburgica.*

the other hand. Afterward a glass cylinder was used instead of sulphur.

In 1740 Winckler substituted cushions of horse-hair as rubbers. In 1760 Ramsden substituted a circular glass plate for the glass cylinder. The forms of electric machines now used are modifications of Ramsden's. This is one of the forms of apparatus from which we obtain statical electricity. Fig. 7 represents the common cylinder electrical machine, for developing electricity by friction.

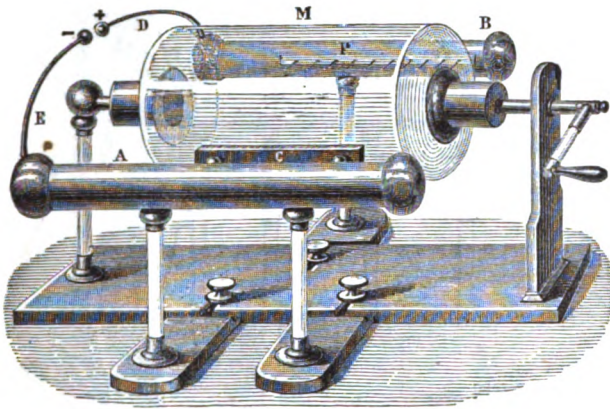

FIG. 7.

*Holtz's Electrophorus Machine.*—The best and most recent form of apparatus for statical electricity is the electrophorus machine that was invented by Holtz,\* of Berlin, in 1865. In this machine the electricity is generated not by friction, but, as in the electrophorus, by *inductive action*. The machine consists of two glass disks and paper coatings, with a number of conductors. One of the disks revolves on its axis; the other remains immovable. The disks and paper coatings are covered with sealing-wax.

The metallic conductors are made in a comb-shape. An incision in the immovable disk, with the paper coating and metallic conductor, is called an element. The machine may have two, four, six, or eight of these elements. When rotated, the paper coating becomes charged with negative electricity: the corresponding part of the movable disk becomes charged with positive electricity. The conductor corresponds to the finger of the experimenter. The length of the spark produced

\* A similar machine was constructed about the same time by Töpler.

by the machine depends on the size of the disk, which may be 12, 21, or 30 inches in diameter. These machines are also called *rotation multipliers*, because by their rotary motion they multiply by successive transmissions the charge of electricity that they communicate.

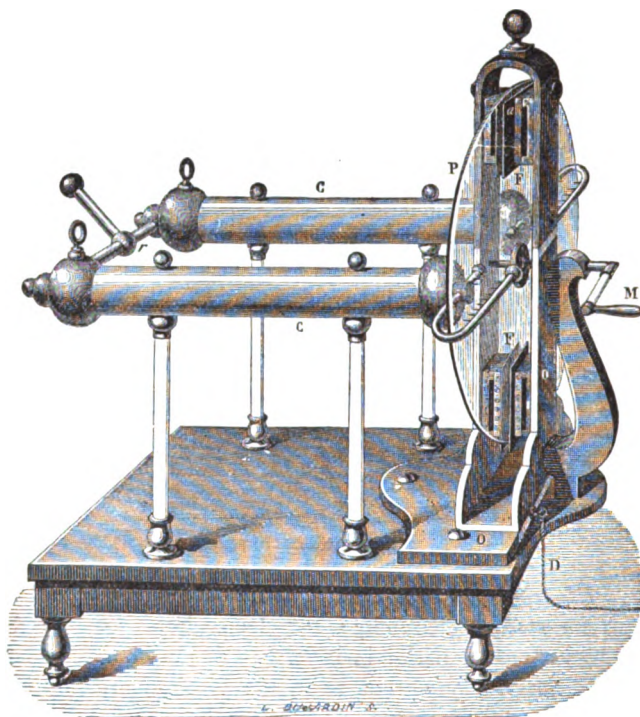

FIG. 8.

*Electric Spark.*—An interesting phenomenon connected with the electrical machine is the electric *spark* which is drawn from the conductor when the finger is presented to it.

The positive electricity of the conductor decomposes the electricity of the body, attracting the negative and repelling the positive, and, when the tension is great enough, these opposite electricities overcome the resistance of the air and recombine, with a spark and crackling sound. The spark is accompanied by a prickly sensation. When the spark is short it is straight; beyond two or three inches in length it becomes curved or zigzag, like the lightning in the sky.

The human body may be charged with electricity by sitting on an insulating stool and touching the conductor of an electrical machine.

When the body is thus charged, the hair diverges, a peculiar sensation is felt in the face, and if any other person standing on the ground touches one so charged, he receives a spark, with a crackling sound and a pricking sensation.

*Electrophorus*.—The electrophorus, invented by Volta, in 1775, consists of a metallic mould, filled with a mixture of shellac and turpentine, and a movable metallic cover that is provided with a glass handle. The surface of the shellac is negatively electrified by beating it with a cat's fur or fox-tail. The cover is then put on, and by contact becomes negatively electrified, and gives to the finger a slight spark of negative electricity. If the cover be now removed by its insulating handle, it gives positive electricity to whatever touches it. This positive electricity it acquires not directly from the shellac, but by *inductive action* through the air.

*Gold-Leaf Electroscope*.—By this instrument we are enabled not only to detect the presence, but to determine the kind, of electricity that may exist in any body.

Fig. 9 represents Bennett's electroscope. B is a tubulated glass



FIG. 9.

shade, enclosed at its lower end by a metallic cover, by means of which it communicates with the ground. A metal rod, fitting in the tubule of the shade, terminates at its upper extremity in a knob, C, and at its lower extremity it holds two narrow strips of gold leaf. On the inside of the shade are two strips of gold leaf reaching to the metal cover



If a body charged with either kind of electricity is brought in contact with the knob, the gold leaves diverge.

*Thomson's Quadrant Electrometer.*—A far superior instrument for all delicate researches is the *quadrant electrometer* of Sir William Thomson. This instrument is quite complex, and only in a general way shall we attempt to describe it. A delicate aluminum needle, two inches long, is hung by two cocoon threads in a glass jar, which is one-sixth filled with sulphuric acid. From the needle a delicate thread of platinum drops into the acid. The needle is thus free to swing horizontally a little distance, or until the torsion of one of the threads by which it is hung forces it back to its original position. Above the needle a very delicate mirror is suspended. When the aluminum needle is charged with electricity, which is conducted through the sulphuric acid and carried up the platinum wire, the needle is repelled or attracted according as the electricity is positive or negative. Behind a screen, at some little distance, is placed a lamp, the light of which reaches the needle through a slit in the screen. On the screen is a scale; a very slight movement of the needle is reflected by the mirror above it on the scale. An exceedingly slight displacement of the needle

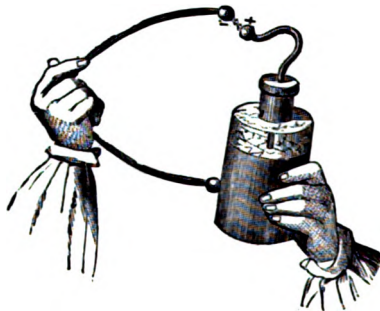

FIG. 10.

will cause a very large displacement of the image reflected on the scale. Thus this instrument is of great value in very delicate researches.

*Leyden Jar.*—The Leyden jar is made of glass, with a coating of tin-foil pasted carefully inside and out, extending to within a few inches of the mouth. Through a varnished wooden cover a wire, having a knob at top, is passed, and extends to the inside coating. Now, when either positive or negative electricity is communicated to the knob at the top, it is immediately diffused over the whole inside coating; and by its inductive influence the outside coating takes on the opposite kind.

When in this state,—the two coatings being oppositely electrified,—the jar is said to be charged; and a *discharge* takes place when a communication is established between the knob and the outside coating, the equilibrium being restored with a bright flash of light and a sharp report.

As the human system is a good conductor, this discharge may take place through it, by grasping the outside coating with one hand, and touching the knob at the top with the other; or several persons may form a line by grasping hands, the one at one extreme touching the outside coating, while the one at the other extreme touches the knob. All will feel the *shock*, as it is called, at the same instant. While the jar is receiving the charge, it must not be insulated; that is, the outside must communicate with the earth. As the positive fluid collects on the inside, the outside becomes negative by the expulsion of the positive fluid naturally in it, and the accumulation of the negative fluid in its stead, drawn from the earth. But if the outside is insulated, these transfers to and from it cannot take place, and therefore the jar cannot become charged.

A submarine cable is really a vast Leyden jar. The wire constitutes the *interior* coating, the water the exterior coating, and the gutta-percha the insulator between them. On this account the passage of an electric current through a submarine cable is greatly retarded.

*History of the Leyden Jar.*—In October, 1745, a bishop of Cammin, in Pomerania, Von Kleist by name, passed through a cork in the neck of a flask an iron nail connected with an electrical machine. The flask contained mercury or alcohol. On touching the nail, Von Kleist received a severe shock. In January, 1746, Cuneus, Allamand, and Musschenbroek passed a wire from an electrical machine into a flask filled with water. Musschenbroek held the flask in his right hand, and when a turn was given to the machine, he received a spark from the conductor with his left hand.

The spark was so terrible that he declared he would not receive another like it for the French crown. He observed what Kleist did not, that only the person who *held the jar* received the shock. In this experiment the *hand of the observer* corresponded to the outer coating of the ordinary Leyden jar. He was the most scientific of the three Leyden philosophers who have given the name to the Leyden jar.

The theory of the Leyden jar, and apparatus similar to it, was given by Franklin in 1747. In the same year Watson, Bishop of Llandaff, sent a discharge from a Leyden jar through 2,800 feet, and subsequently through 10,600 feet of wire.

Experiments like these were also made by Franklin across the Schuylkill.

For a long time Franklinic electricity was the only form used in electrotherapeutics. At present it is but little used except in certain hospitals and public institutions. Its value as a therapeutic agent is, however, unquestioned, and now that some of the inconveniences attending its use have been removed by Holtz's machine, it is just that it should have a fair and careful trial at the hands of modern electrotherapeutists.



## CHAPTER III.

### GALVANISM, OR VOLTAIC ELECTRICITY.

**UNDER** the general term *Dynamical Electricity* is included the electricity which arises, *first*, from chemical action—especially from that attending the dissolution of metals—called *galvanism* or *voltaic electricity*; *secondly*, from induction by currents or magnets, called *induced electricity*, *electro-magnetism*, or *magneto-electricity*; *thirdly*, from heat, called *thermo-electricity*. These varieties are called *dynamical* electricity, signifying *electricity* in motion as distinguished from *frictional* or *statical* electricity, which denotes the electrical condition of bodies in which electricity remains insulated or stationary. Strictly speaking, these terms—*dynamical* and *statical*—are applicable to both branches of the science; for if the poles of a series of galvanic batteries are insulated, they manifest, before the current begins, the electric tension of a friction machine. Again, the characteristics of the galvanic current are manifested slightly in the series of discharges which are transmitted in a wire connecting the prime conductor of a machine in action with the ground or other negative conductor.

*Nature and Definition of Force and its Relation to Matter.*—*Force is that which produces motion.* It is itself a primary motion and cannot be defined. Matter is a collection of centres of force called atoms. Molecules are collections of atoms. A molecule is the smallest particle into which a body can be divided without losing its identity.

The molecules of a gas are in rapid and continuous motion, and the relative velocities in different gases has easily been determined. These motions and velocities are the result of the forces of which matter consists. It must be similarly true of liquids and solids: *force and motion are the bases of their constitution.* Indeed, without force matter would not exist at all, for matter is simply an aggregation of centres of force.

*Ponderable Matter* is a form of force which our senses recognize. *Ether* pervades all matter and all space, but it is not recognized by sense, and yet it is none the less a manifestation of centres of force.

*Electricity compared with other Forces.*—If force be added to matter

the equilibrium of that point is disturbed, and the disturbance is propagated from molecule to molecule, through matter, or ether, or both. Heat by conduction and mass-motion are of matter only. Heat by radiation and light are of the ether only. Electricity is now regarded as a movement of the ether, and of the body in which it circulates. Chemical action is a rearrangement of atoms. After this action the sum of the activities of the molecules of the resulting product is different from that which its factors previously had. This difference is force, and appears sometimes as light, and under certain conditions as electricity, but it is rarely or never confined to one mode of manifestation. *The condition for the generation of electricity by chemical action appears to be that this action takes place at the surface of a conductor through which a current (so called) can circulate.* Since the current is made of motion of the molecules of the conductor through which it passes, and of the ether, the nature of the conductor must modify the current itself. It is known that the current through a telegraph-wire 500 miles long meets the greater part of its resistance in the first 100 miles. The current is modified by the material and length and size of the wire.

The differential physiological effects of induction-coils of different lengths and fineness may thus be in part explained. These differential effects will be spoken of in the electro-therapeutical portion of this work.

*The Chemistry of the Battery not yet Exact.*—Chemistry can never be an exact science until temperature, specific heat, and matter are all considered, and justly estimated in all reactions. This has not yet been accomplished.

We are unable to state *a priori* what must be the electro-motive force of the different batteries in use, since that, as we have seen, depends on data hereafter to be determined. Frequently, however, we are able to state which of two reactions must evolve the greater force, and so, under like circumstances, the stronger electric current. This is done by inspection of the electro-chemical series of elements. That series, however, must vary with the temperature, so that it is no sure guide.

*Office of the Water in the Battery.*—The water used in all common batteries serves as a solvent of the salt formed in the reaction. When the water used becomes saturated by this salt the current stops, and it declines in power as the solution approaches saturation.

*Office of the Metals in the Battery.*—Of the two metals in any battery one only enters into the reaction. Zinc has generally filled that place in all the best-known batteries, because it is nearer the negative

end of the electro-chemical series than any other common and convenient metal. Potassium or sodium would be the *beau ideal* of the negative metal, but they are not convenient or practicable. Any metal or conductor which is not acted on by the fluid in which it is immersed may occupy the other place in the couple.

All modern research tends toward the conclusion that the different forms of electricity which we variously distinguish as *magnetism*, *Franklinism*, *galvanism*, *electro-magnetism*, are but expressions of one force, which force is, as we have seen, but a mode of motion of the universal ether. Very recently a European physicist has estimated the electromotive force of Holtz's machine, and has expressed it in a mathematical form, so that it may be compared with the ordinary galvanic batteries.

In the present chapter we shall speak of the form of electricity that is generated by chemical action—*galvanism* or *voltalism*. Analogy and experience make it more than probable that *all chemical action whatsoever is attended with the evolution of electricity*; and reasoning still further we may believe that all molecular disturbance, however excited, must give rise to electrical disturbance. The play and interplay of electrical phenomena are incessant and infinite; electrical force, like light and gravity, is everywhere being generated and everywhere acting. If we are unable to detect the electricity generated by chemical action only under certain conditions, or when generated in comparatively large quantities, it is because of the imperfections of our knowledge and the want of sufficient refinement in our apparatus for collecting and measuring electricity.

As a matter of experience it is found that chemical electricity is most conveniently generated by the reactions that take place between two metals and some acid solution, and as a matter of convenience and economy zinc is the metal at the expense of which the electrical force is evolved, the other metals acting merely as conductors; but the combinations that are actually employed by physicists are but a fraction of those that are possible and conceivable.

Every year new batteries and modifications of old batteries are devised, but all of them are based on the general principle that chemical action of any sort whatsoever is attended by the evolution of electricity.

We present below brief descriptions of some of the principal batteries that are now in use. All, or nearly all of them, in their original shape, or under various modifications, are used in electro-therapeutics. We shall not attempt to exhaust the list, but to illustrate those that are best known, most useful, and are most thoroughly representative. Those

who understand the principle on which these batteries are constructed will not find it difficult to understand any new modification of them that may arise.

Here let us interpose the remark, that the time and energy that are devoted to the study of the chemistry of batteries will not be wasted time—will indeed be spent most wisely—for half the annoyances of young and old electro-therapeutists comes from the difficulty of keeping their batteries in order. This difficulty will be diminished one-half and more when we really understand the mechanism of batteries and the laws that govern their action.

*Simple Galvanic Circles.*—In the formation of a simple galvanic circle there are usually metals and a liquid.

Fig. 11 constitutes such a circle.

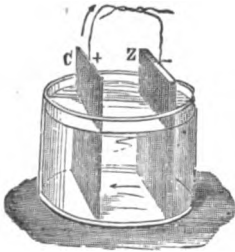

FIG. 11.

Let C and Z represent respectively plates of copper and zinc introduced into dilute acid, and connected by a wire. An electrical disturbance takes place over all the surface of the zinc covered by the liquid. Positive electricity is generated at the zinc element, and flows through the liquid to the copper, and thus a constant current is established over the wires, as shown by the arrows.

So far as the galvanic action is concerned, it matters not whether the plates touch each other or are connected by wires, as in the figure. A current is formed, whether contact is made between the plates either above or below the liquid. In every instance, however, a *circuit* must be formed, around which the electricity may flow.

The electricity may traverse the circuit either in a single current or in a number of *partial currents*, into which it may divide itself when the plates are brought in contact along their whole surfaces. When the plates, or the wires which connect them, are in contact, the circuit is said to be *closed*; when they are separated, it is said to be *broken*, or *open*. The electricity is generated wholly by the chemical action of the acid upon the zinc, and, other things being equal, the quantity of electricity set in motion will be proportional to the extent of zinc surface exposed to the acid.

*The terms Electro-positive and Electro-negative.*—Both in simple and compound circles the electricity always moves *in* the liquid of the battery from the zinc to the copper; and *out* of the liquid, from the copper to the zinc. This should be remembered, *since the ZINC is*

*called the electro-positive element, although out of the liquid it is negative*; and, consequently, in the decomposition that occurs in the battery, that element which goes to the zinc pole is called the electro-positive element, being attracted by its opposite force; while the element going to the copper is called, for the same reason, the electro-negative—a current from two liquids and one metal.

Two liquids and one metal can also produce a circuit as well as one liquid and two metals. Becquerel's oxygen battery (*pile à oxygène*) is one of the best arrangements of this kind. The current is produced by the action of caustic potash on nitric acid, platinum forming the conducting arc.

*Homogeneity of the Galvanic Circuit.*—In *frictional* electricity there are points which form the seat of + or - electricity. On the contrary, in a wire where a galvanic current is circulating, there are no such points. It has no power, like frictional electricity, to attract or repel objects. The wire feels and behaves no differently when the current is passing than when it is not. The wire conducts so much better than the air that the current follows it. Its force is the same at every point, in the battery or in the circuit. Making interruptions in it at different points, and sending currents through solutions of sulphate of copper, the same amount of copper is deposited at each of the places where the interruption is made. If we connect the several breaks by pieces of platinum wire, each wire will be heated to the same temperature.

*In short, the magnetic-heating and chemical and other effects of the current are the same at every point in the circuit.*

*Polarity of the Circuit.*—If the wire in which the current runs be cut or broken at any point in the circuit, the current ceases to flow—that is, ceases to be *dynamic*, but at the two cut ends there is *statical electricity*. One end of the cut wire will be charged with + and the other with - electricity. The amount of this statical electricity will depend on the original strength of the current before the interruption was made.

By the condensing electroscope it can be shown that each end of the cut wire is charged with an opposite electricity, and the amount of this can be estimated. If we take away any part of the wire entirely from the circuit, the piece of wire taken away is out of the circuit entirely; but if the ends of the wires at each point of interruption be dipped in a fluid that is decomposed by the current, the circuit will be again completed, and it will be found that the part of the wire that is taken away has opposite electricities at the ends.

Similarly, also, the solution in the battery and the metals themselves, like the connecting wire, are + at one end and - at the other. The circuit throughout consists of + following - and - following +. It appears to be electrically the same throughout.

*Electrical Relations of the Elements.*—In the galvanic cell, by the decomposition of the water, oxygen arises at the positive pole and hydrogen at the negative.

The metals assume opposite electricities, the zinc being positive and the copper negative.

Since electricities that attract each other are opposite to each other, the substances that are liberated at the positive pole are called *electro-negative*, and the substances liberated at the negative pole are called *electro-positive*. Thus, in the decomposition of the battery, oxygen which is liberated at the zinc is electro-negative, while hydrogen which is liberated at the copper or platinum is electro-positive.

The elements have been arranged as to their electro-chemical relations when associated in pairs in the galvanic cell. According to recent chemistry, atoms are arranged in two classes, according to their combining power. *Positive* atoms are those which are attracted to the *negative* electrode in electrolysis, and whose hydrates are bases. *Negative* atoms are those that are attracted to the positive pole in electrolysis, and whose hydrates are acids. The electro-chemical series are presented below :

*Electro-Chemical Series.*

<i>Negative end —.</i>	Silicon.	Zinc.
Oxygen.	Hydrogen.	Manganese.
Sulphur.	Gold.	Lanthanum.
Nitrogen.	Osmium.	Didymium.
Fluorine.	Iridium.	Cerium.
Chlorine.	Platinum.	Thorium.
Bromine.	Rhodium.	Zirconium.
Iodine.	Ruthenium.	Aluminum.
Selenium.	Palladium.	Erbium.
Phosphorus.	Mercury.	Yttrium.
Arsenic.	Silver.	Glucinum.
Chromium.	Copper.	Magnesium.
Vanadium.	Uranium.	Calcium.
Molybdenum.	Bismuth.	Strontium.

Tungsten.	Tin.	Barium.
Boron.	Indium.	Lithium.
Carbon.	Lead.	Sodium.
Antimony.	Cadmium.	Potassium.
Tellurium.	Thallium.	Rubidium.
Tantalum.	Cobalt.	Caesium.
Columbium.	Nickel.	<i>Positive end +.</i>
Titanium.	Iron.	

Each atom of any of the substances in this list is positive to any atom of any substance above it, and negative to any one below it. These distinctions are therefore purely relative.

Thus, for example, copper, when associated in a galvanic pair in the proper fluid with any one of the elements below it, generates positive electricity and becomes electro-positive, but when associated with any one of the elements above it, becomes electro-negative.

The more electro-negative any one of the elements in this series is to a given element, the more intense will be the current generated when they are united in a galvanic pair. For example, the current generated by zinc and copper is feebler than that obtained from zinc and platinum, and the current is less when carbon is substituted for the platinum. The order in the above arrangement is, however, by no means absolute. The relative position of the metals depends frequently on the liquid in which they are immersed. Thus silver is — toward lead in a solution of dilute sulphuric acid, while in a solution of cyanide of potassium it is + toward it.

*Amalgamation.*—If pure zinc is immersed in dilute sulphuric acid no change is manifest, while ordinary commercial zinc is quickly dissolved by it. The action of the dilute acid on zinc is due to the impurities of iron or lead which it contains. These impurities are electro-negative toward zinc, and they cause *local currents of electricity*. When the battery is closed, these local currents interfere with the action that produces the main current; when the current is open, they may still keep up their action, as is evidenced by the bubbling up of the gases, and thus the zinc may be in time destroyed.

Now, local action in a single battery cell, arising from the above cause, not only consumes the power of that member, but reduces the energy of the whole series. In order to avoid this evil, resulting from local action, it is necessary that the zinc plates be amalgamated with mercury. The amalgamated surfaces are reduced to one uniform electrical condition, like pure zinc, and will remain in the fluid for any

length of time unacted on, until connected with the electro-negative element.

At the present time all improved batteries are constructed with amalgamated zinc.

*How to amalgamate Zinc.*—To amalgamate zinc, first immerse it in a solution of dilute sulphuric acid of almost any strength, so as to clean the surface; then dip it in mercury, or pour mercury over it, and rub it on with a brush or sponge or cloth. The mercury will spread very rapidly over the surface of the zinc, and give it a bright, mercury-like appearance.

The art of amalgamating zinc is of great practical importance to the electro-therapeutist, since nearly all the batteries in common use have zinc for one of the metals. Amalgamated zinc was first used for galvanic batteries by Kemp, in 1826.

*Chemical Action the Origin of the Current.*—When the electrically opposite metals—zinc and platinum, for example—are dipped in acidulated water and united at their ends, either directly or by a wire, the zinc has so strong an attraction for the oxygen of the water that it unites with it and forms the oxide of zinc. This oxide of zinc combines with the sulphuric acid and forms sulphate of zinc. The hydrogen of the water escapes in the form of gas at the platinum. *The result of this chemical action is a current of electricity.* The zinc (the electro-negative element) dissolves, and the quantity of electricity generated is proportioned exactly to the quantity of zinc dissolved.

It had been supposed by Volta and his followers that simple *contact of the metals* was all that was necessary to excite the current; but Faraday showed, by two very beautiful experiments, that *mere contact* was not sufficient—that there must be *chemical action* in the cell in order to obtain a current. It is possible that all chemical actions are attended with the generation of electricity; but only under certain conditions, or when the amount is considerable, are we able to detect it.

*In what way does Chemical Action generate the Current?*—In science it often happens that the simplest and easiest questions are the hardest to answer. Just how the current is excited by chemical action we do not fully know. We know that when the different metals touch each other, the positive electricity will go to one metal and the negative to the other. This disturbance, however, is only momentary, and equilibrium is at once restored, and no current continues.

Now we may regard the atoms of oxygen and hydrogen that make up a molecule of water as charged with opposite electricities, like two different metals. When zinc and platinum are dipped in water, the



positively charged atom will turn toward one metal and the negative toward the other; but as long as the metals do not touch each other the equilibrium is at once restored, and there is no current. The free ends of the metals are in a state of electric tension, and are capable of discharging themselves into a condenser or Leyden jar. When the *metals are made to touch each other, or are connected by wires*, they are relieved of their charge, and again become charged; then again relieve themselves, and so on indefinitely. There is no equilibrium established, but a constant effort to establish it, which never succeeds. This constant effort to establish an equilibrium keeps up the current.

*Electricity a Mode of Motion.*—Although, for the sake of convenience, we speak of electricity as a current flowing in certain directions, after the manner of a river, yet, as we have already said, we should not thereby be led into the error of supposing that the electricity is a real fluid flowing through different substances, or from one substance to another.

*Electricity is a disturbance propagated in the Molecules of a body, and at the same time in the Ether pervading that body.*—The theory that light was caused by the emission of particles from the sun was abandoned long ago; and now the theory that light consists of *undulations of ether* is considered to be as impregnable as the theory of gravitation. Similarly we may believe that electricity consists of movements of a different kind from those of light, but which is variously modified in its manifestations by the substances through which it circulates.

The impulse or movement that constitutes what we call the current may be regarded as simply a mode of motion.

*Polarity of Electricity.*—*Polarity, or properties in opposite directions*, is not peculiar to electricity. Light and heat may also be polarized, and chemical attractions and repulsions are likewise manifestations of the polar qualities of atoms. We may gather a definite idea of the nature of electricity and the character of the so-called "current" by the following illustration: Let a tube be filled with balls, all of which are attracted to each other. If the first ball is turned round on its centre, it will turn in a similar way the next ball, and so on through the whole series. There is here no progress of a material current, but simply a *motion*.

If the motion is rapidly repeated through the attempt of electricity to find an equilibrium, we have what we call an electrical current.

*Electricity convertible into the other Great Forces.*—We see in this section on electro-physics many illustrations of the transformation of one force into another. If we start with heat, we find that it pro-

duces electricity, and through electricity produces chemical action, magnetism, and light. If we start with magnetism, we find that it produces electricity, and through electricity heat, chemical action, and light. If we start with chemical action, we find that it produces heat, light, and electricity. If we start with electricity, we find that it produces magnetism, heat, light, chemical action, and motion.

*Conversion of Electricity into Heat. The Electric Light.*—By the law of the correlation of forces the electricity generated in a battery may be converted into heat. This heat may remain in the battery or be transferred to any part of the circuit. In order to convert the electricity into heat it must pass through some poor conductor that resists its passage, and thus compels it to appear as heat. With ordinary thick copper wire there is but little sensible heat in the passage of a current, because copper wire is a good conductor; but when platinum wire, which is a poor conductor, is used, it is raised under a strong current to white-heat. This has been utilized in *galvano-cautery*.

In the *electric light* the heat is transferred to carbon points interposed in the circuit. Particles of carbon become incandescent, and are volatilized and transported from the positive to the negative pole. A metal or other substance may give an electric light, but carbon, on account of its friability, gives a better and stronger light than any other substance. The electric light was invented by Sir Humphry Davy in 1813.

*Compound Galvanic Circles.*—The compound galvanic circle, or gal-

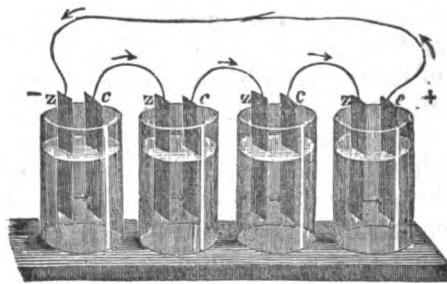

FIG. 12.

vanic battery, is composed of two or more simple galvanic circles. They are so connected together that the copper of one battery is joined to the zinc of the next, and so on throughout the series. By combining together a number of cups, such as are represented in Fig. 12, we form

an excellent compound circuit. Each cup contains a zinc and a copper plate, which are connected together as described above. By examining this arrangement, it will be seen that one extreme of the series is copper and the other zinc. If these two extremes or poles are connected by a copper wire, the current will flow in the direction of the arrows, both through the series and over the wires.

*Derived, or Partial, or Branch Currents.*—When a current in its passage through any conductor meets with different qualities of resistance, it subdivides into various branch currents. In Fig. 13 the current goes from the elements through the wire  $r, g, p, n, m$ ; but if a

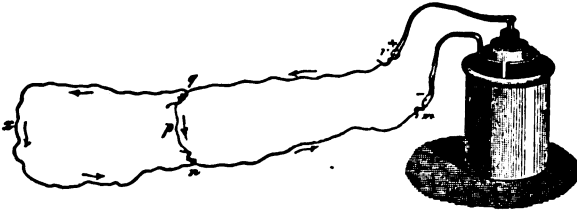

FIG. 13.

second wire,  $n, x, g$  be interposed, the current will divide at  $g, n$ , part going by way of  $g$  and part around through  $x, n$ . The divided currents which go through the wires are called derived or partial currents. If, instead of one or two wires, a large number were interposed, the current would subdivide itself as many times as there were wires, part going through each wire.

In thus dividing into derived or partial currents, two laws are obeyed :

1st. *The sum of the strength of the divided current is equal to the strength of the principal current.* If (in the figure) the strength of the current  $g, p, n$  is 40, and  $g, x, n$  is 60, then the strength of the principal current in  $r, g$ , before division, is 100.

2d. *The strength of the currents in the divided parts is inversely as the resistance in those parts.* This law supplements the first. Resistance is directly as the length and inversely as the diameter.

If the derived wires are of the same length and diameter as the principal wire, then the current will divide into equal parts between them. If the derived wires are of the same length as the principal wire, but of unequal diameters, the current will divide unequally, according to the diameter of each wire. The law may be illustrated by thinking of the course that rivers pursue when they are subdivided or split up into

deltas. The quantity of water that flows through all the subdivisions or deltas would be equal to the quantity that flowed through the main stream before the divisions took place. If the subdivisions are of different sizes, the deepest and widest will convey the most water.

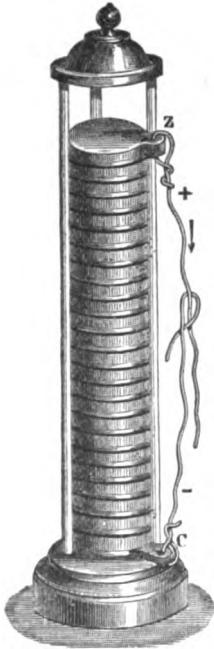

FIG. 14.

When electricity passes through the human body it encounters tissues that differ considerably in their conductivity, and hence it subdivides into an infinite number of derived or partial currents, the strength of which varies with the nature and length of the tissues. This point will be further illustrated in electro-physiology and electro-therapeutics.

*Description of Galvanic Batteries.*—Under this head may properly be included, first, a description of the *voltaic pile*, which was constructed by Volta in 1799, and became known in England in 1800. The apparatus consists of a number of disks piled one above the other. The arrangement is in the following order: A disk of copper is placed on a frame of wood; a disk of cloth, moistened with acidulated water, is then placed on the copper, and then a disk of zinc on the cloth completes what is called the voltaic couple. A series of such couples constitutes a voltaic pile—the terminal copper being the positive and the terminal zinc the negative pole.

This apparatus is inconstant and unreliable, easily corrodes, has many inconveniences, and is now but little used. Various modifications of the voltaic pile have been devised, but all of them are too inconstant for electro-therapeutical purposes, or indeed for any sustained use whatsoever.

*Polarization in Batteries.*—When two metals, as zinc and platinum, are placed in acidulated water, the platinum plate becomes covered with a film of hydrogen. This hydrogen is electro-positive, like zinc, and so when the platinum becomes well covered we have electro-positive zinc opposed to electro-positive hydrogen, and thus the current becomes enfeebled, if not destroyed. This polarization in batteries is prevented in two ways:

1st. By keeping the liquids in constant agitation. Blowing into the liquid with a bellows, or stirring the liquid by any mechanical arrange-

ment, keeps the surface of the platinum or carbon free from hydrogen, and thus prevents the weakening of the current.

Dr. Byrne, in his galvano-cautery battery (to be described in the section on Electro-surgery), has availed himself of this depolarizing power of mechanical agitation, and has thus succeeded in obtaining a great and enduring quantity of electricity from a comparatively small surface.

On the same principle we explain the fact that lifting the metals out of the liquid for a moment or two at once increases the strength of the current. While in action, the hydrogen accumulates on the platinum; by removing the metals from the liquid an instant, the hydrogen escapes and the battery is as good as ever.

2d. By the use of *two* liquids. The cells of Grove, Daniells, and Bunsen, to be hereafter explained, are constructed so as to avoid polarization of the metals.

*Polarization of Electrodes and Currents of Polarization.*—The electrodes that convey the current through acidulated water also become polarized.

Oxygen covers the positive and hydrogen the negative electrode. Hydrogen being electro-positive, and oxygen electro-negative, these two gases act like two metals, and if the current of the battery be broken and the two films of oxygen and hydrogen are connected metallically, an electric current is obtained, just as a current is obtained between zinc and platinum. In the liquid the current flows from the film of hydrogen to the film of oxygen. Two electrodes covered in this way with films of gas are called *polarized*, and the currents generated by these are called the *currents of polarization*. These currents of polarization are always in a direction opposite to the main current, and tend to interfere with and weaken it. This polarization of the electrodes takes place more or less in all applications of the galvanic current. One evidence of this is the discoloration of the electrodes that are employed in electrization after long use. To meet this difficulty *unpolarizable* electrodes have been devised. These will be described under Electro-therapeutics.

*Secondary Piles and Gas-Batteries.*—If a series of plates of platinum, with moistened cloths between them, be connected with the poles of a battery, the gases (oxygen and hydrogen) resulting from the decomposition of the water accumulate in films on the platinum. If now the series be separated from the battery, it will itself, through the action between these films of gases, generate a current. A pile thus formed is called a *secondary pile*. It was discovered by Ritter. The gas-battery of Grove is constructed on the same principle. The gases are

collected in glass tubes, oxygen in one and hydrogen in the other, and in each tube is fastened a platinum electrode. The tubes are inverted over sulphuric acid. When the electrodes are connected with a galvanometer a current is indicated, the direction of which is from oxygen to hydrogen.

There are two general varieties of batteries, *double* and *single cell*.

*Double-cell Constant Batteries.*—The current produced by elements with a single liquid becomes rapidly enfeebled, because of the polarization. This *polarization* is prevented in the double-cell batteries of Daniell, Grove, and Bunsen, by placing the electro-negative element in a liquid that is acted upon chemically by the deposited hydrogen. Currents from these two-cell batteries are called *constant*, because they do not weaken so rapidly as currents from single-cell batteries, and the metals can be allowed to stand all the time in the solution.

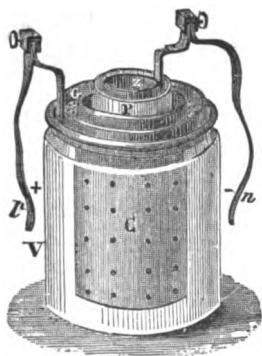

FIG. 15.

The term constant is now applied to the *galvanic* current, however generated, as distinguished from the induced or faradic current.

*Daniell's Battery.*—Fig. 15 represents a single cell. V is a glass or porcelain vessel nearly filled with a saturated solution of sulphate of copper. C is a cylinder of copper, open at both ends and perforated by a number of holes. G, which is also perforated by holes, is an annular shelf at the upper portion of the zinc cylinder, upon which crystals of sulphate of copper may be placed to supply the waste in the cell caused by the electrical action. P is a thin porous vessel of unglazed earthenware, containing the amalgamated cylinder of zinc Z, and a solution either of common salt or dilute sulphuric acid. The elements are connected in series by strips of copper, *p* and *n*, which are fixed to the copper and zinc by means of binding-screws. When the circuit in the battery just described is closed, an atom of zinc replaces and liberates from the nitric acid two atoms of hydrogen, thus producing sulphate of zinc. The liberated hydrogen replaces one atom of copper in the sulphate of copper, which by electrolytic action is deposited on the copper element, or sometimes on the porous cup. Polarization is the resistance to the passage of the current produced by a deposit (such as hydrogen) on

either of the elements. No such deposit occurs in this battery, hence the current is constant.

Order of the parts in Daniell's sulphate of copper battery: 1st, zinc; 2d, sulphuric acid; 3d, porous cup; 4th, sulphate of copper; 5th, copper.

### *Reaction.*

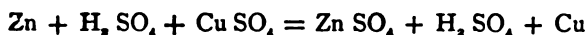

The current obtained from this battery will flow with undiminished strength for hours, and, in fact, is superior to all its fellows in constancy. Daniell's battery was invented in 1836. The modifications of Daniell's battery are quite numerous; among them we may mention those of Hill, Siemens-Halske, and Muirhead.

*Grove's Battery.*—This battery differs from Daniell's mainly in the substitution of a nitric-acid for a sulphate-of-copper solution, and platinum for copper, by which increased electro-motive force is obtained. In Fig. 16, A represents a glass vessel containing dilute sulphuric acid, Z a cylinder of zinc open at both ends, and V a porous pipe-clay vessel partially filled with nitric acid. P is a plate of platinum, with a cover, C, which rests on the porous vessel when the platinum is immersed in the nitric-acid solution; *b* and *a* are binding-screws, which connect respectively with the platinum and zinc.

In this arrangement a double reaction occurs between the zinc, sulphuric acid and nitric acid, giving as a result, sulphate of zinc, water and nitrogen dioxide, which is disengaged, and by contact with the air becomes nitrogen tetroxide. The reaction in Grove's nitric-acid battery is as follows: 1st, zinc; 2d, sulphuric acid; 3d, porous cup; 4th, nitric acid; 5th, platinum.

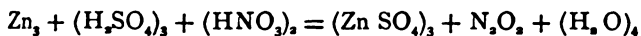

also  $\text{N}_2\text{O}_4 + \text{O}_2 = \text{N}_2\text{O}_5$  by contact with the atmosphere. Force must be lost by the evolution of these nitrous fumes. Prof. Wolcott Gibbs, of Cambridge, has discovered that a small quantity of bichromate of potash in the nitric-acid cup of Grove's battery acts as a deodorizer by taking up the disagreeable nitrous acid fumes. Thus one of the most serious objections to the use of this battery is removed. Grove's battery was invented in 1839. It is very powerful, and is

much used in telegraphy. It has also been employed in **galvano-cautery**.

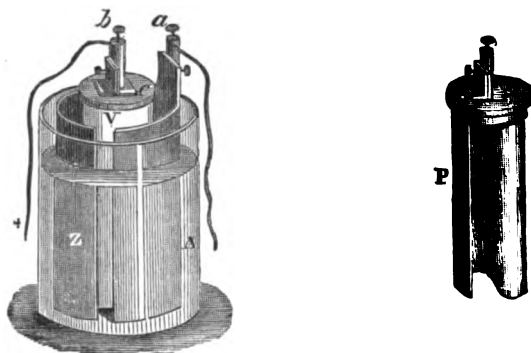

FIG. 16.

*Bunsen's Double-cell Nitric Acid Battery.*—This battery is very similar to Grove's. It differs from it only in the substitution of carbon for platinum. The letter P in Fig. 17 represents a single element, as it appears when ready for use.

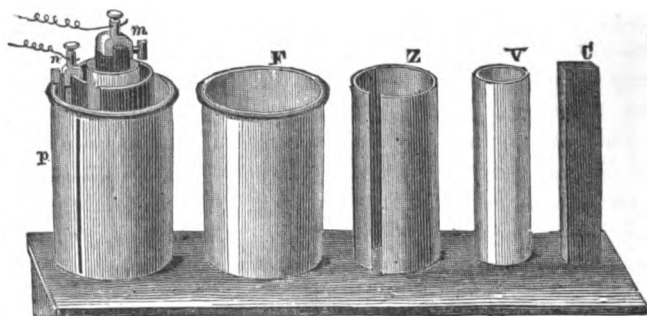

FIG. 17.

F is a vessel of glass containing dilute sulphuric acid. Z, a cylinder of amalgamated zinc. V, a porous vessel partly filled with ordinary nitric acid; and C, a bar of carbon or coke. The zinc is first placed in the vessel F, after which the porous vessel V, into the nitric-acid solution of which the carbon C has been immersed, is inserted into the zinc cylinder. The binding-screws *m* and *n* are respectively the positive and negative poles. The elements are arranged in the form of a



compound battery, by means of the clamp *m n*, and a rod connecting the carbon of one cell with the zinc of the following.

*Bunsen's Bichromate Battery.*—In this battery a solution of *bichromate of potash*—one part to twelve parts of water—is placed in the porous cup.

The order of the parts in Bunsen's Bichromate Battery is as follows :

1st, zinc ; 2d, sulphuric acid ; 3d, porous cup ; 4th, sulph. acid and bichromate of potash ; 5th, carbon.

*Reaction.*

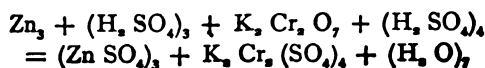

*Chrome-alum, sulphate of zinc, and water,* are the products. The office of the porous cup is to keep the bichromate of potash from the surface of the zinc, and thus more uniformity and constancy of action is attained.

While the action of Bunsen's battery is the most energetic of all the constant batteries, and while the first cost is less than Grove's, it is yet more expensive to work and more inconvenient to manipulate. Bunsen's battery was invented in 1843.

*Walker's Single-cell Zinc-carbon Battery.*—In this battery *carbon* is substituted for the platinum of the Smee battery, and the solution used is composed of bichromate of potash, sulphuric acid, and water, the same as in Bunsen's battery. The carbon is usually the pressed and baked graphite of the gas-works. There is considerable difference in the quality of the carbon as sold in the market ; the more thoroughly it is pressed and baked, the better it will be. Carbons that are poorly prepared, or that contain impurities, easily become soaked with fluid and the salts of the solutions, and also generate local currents that interfere with the main current. Sometimes the carbons are platinized, that is, covered with finely-divided platinum, as is the silver in the Smee battery. The proportion of the solution used in Walker's battery is as follows :

Sulphuric acid,	
Bichromate of potash, āā.....	℥ i.
Water .....	℥ xij.

The reaction is the same as in Bunsen's Bichromate Battery just described.

To prepare this mixture, add the sulphuric acid to the water, and *when this is cool*, add the bichromate of potash well pulverized. Do not immerse the elements in the fluid until it is perfectly *cool*, for when

hot the fluid saturates the carbons and removes the amalgam from the zinc, and thus injures very seriously the working power of the battery.\* The proportions of sulphuric acid and bichromate of potash above given may be varied more or less as may be desired. Mathematical accuracy is not required. If, however, the solution is excessively strong, if the proportion of bichromate of potash and sulphuric acid is too great, say two or three times what is here given, the battery will wear away very rapidly and a greenish-black deposit will be found in the bottom of the cells. This deposit, which sometimes forms very hard, and is difficult to remove without breaking the glasses, is the chromalum, and is a result of the decomposition of the salts and acids that takes place while the battery is in action. Like the Smee battery, the zinc-carbon battery will need to be occasionally amalgamated, but, unlike the Smee battery, it does not require any mercury in each cell, and the presence of mercury will give rise to local action. We speak thus particularly of the simple zinc-carbon battery, because it is one very widely used in electro-therapeutics, and it is important that its management should be well understood. The galvanic batteries of Stöhrer, of the Galvano-faradic Manufacturing Company, and of Kidder, are mostly of single-cell zinc-carbon elements. The zinc-carbon battery, like Smee's, to be hereafter described, is not constant. If the metals are kept long immersed in the solution, the power rapidly goes down. It is necessary, therefore, to keep the metals *out of the solution*, except when the battery is in use. In this respect the battery differs very much from the batteries of Grove, Bunsen, and Lechanché, where the metals are never removed from the solution except to be cleaned and repaired.

*Smee's Battery.*—This battery, invented in 1840, is very economical, convenient, and easy to manage, and on that account has been considerably employed in electro-magnetic apparatus. It consists of a plate of corrugated platinum, or silver covered with finely-divided platinum, between the two plates of zinc, in a solution of sulphuric acid and water (one part to ten or twelve).

The order of the parts in Smee's Sulphuric Acid Battery is as follows :  
1st, zinc ; 2d, sulphuric acid ; 3d, platinum.

*Reaction.*

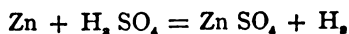

\* It is well known that when sulphuric acid and water are mixed, the solution becomes very hot. The explanation of this is, that in mixing, the atoms of the water are attracted to the atoms of the sulphuric acid ; in other words, *work is done*. The volume is diminished 8 per cent., and the heat that appears is a result of the work thus performed.

The chemical action of this battery is more rapid than that of the sulphate of copper battery, because platinum is more positive than copper, whose place it occupies in the sulphate of copper battery. The disengagement of the hydrogen is effected by mechanical means, but there must be a large loss of force in changing hydrogen to a gaseous state, precisely as force is lost in changing water to steam.

The object of corrugating the platinum plate, or making it into folds or furrows, is to give greater surface. The object in covering it with finely-divided platinum is to roughen the surface so that the hydrogen will not adhere. It is customary in using the battery to keep about half a tablespoonful of mercury in the bottom of the cup, in order that the zincs may be all the time well amalgamated. Care should be taken, in the preparation of this battery, to prevent the mercury from collecting on the platinum plate. If by any carelessness it does get on the platinum plate, it will turn it to the color of mercury, and will weaken or destroy the force of the battery. In this battery more or less action goes on even when the connections are not made; this is evidenced by the formation of sulphate of zinc at the top of the metals after they have been long immersed. It is therefore an advantage in using the battery to keep the elements *out of the solution* when not needed. If kept constantly immersed, like Daniell's battery, it very soon loses its power and becomes thoroughly incrustated with sulphate of zinc.

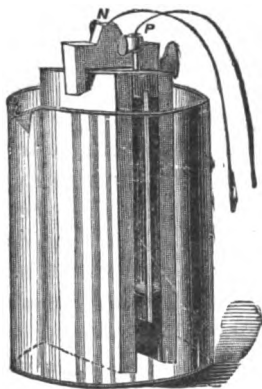

FIG. 18.

*Leclanché's Battery.*—During the past few years, this battery has attracted great attention in Europe, both among telegraphists and electro-therapeutists. The great advantage that is claimed for it, where it is not used too long at a time, is that it is far more constant than any other battery yet invented. The battery was devised by Leclanché, a Frenchman, in 1868, and bears his name. A Leclanché cell consists of, 1st, a cylinder of zinc in a concentrated solution of chloride of ammonium; 2d, a rod of carbon, packed with powdered carbon and native peroxide of manganese in a porous cell. The whole is closed with a cover. The chemical changes that take place in a Leclanché battery are these: Chloride of ammonium is decomposed, chlorine combining with the zinc, hydrogen being absorbed by the oxygen of the peroxide of manganese, and ammonia being liberated. The ammonia is absorbed by the water, but in process of time the water becomes

ducting wires. As the ocean furnishes the exciting fluid, it needs no replenishing. It was hoped that a battery of this kind might be of sufficient strength to furnish an electric light for light-houses. This hope, so far as we know, has not been realized.

*Dry Pile.*—Dry piles have, instead of liquids, some solid hygrometric substances, as paper or leather. There are many varieties of dry piles. Those of Zamboni, which are best known, are composed of tin or silver and binoxide of manganese. A piece of paper is tinned or silvered on one side, and the other side is covered with powdered binoxide of manganese. These sheets are cut into disks, about one inch in diameter, and arranged so that the tin or silver of each disk is in contact with the manganese of the next in the series. A Zamboni pile of 200 couples is very feeble and slow in its action, but it can charge a Leyden jar, and it is quite permanent.

*Instruments for Measuring Electricity.*—The instruments for measuring electricity are quite numerous, and some of them are very delicate. It is necessary here to describe only a sufficient number to illustrate the principles involved.

*The Voltmeter.*—The voltmeter is an instrument devised by Faraday to measure the strength of the galvanic current. It is a graduated tube that receives and accurately measures the quantity of gas that is generated by the decomposition of water by the current in a given time.

In Fig. 19 the platinum needles connected with the poles of the battery are inserted through the cork, at the end of the tube. The gases that result from the electrolysis rise to the top, as the tube is held upright, and repel the water through a hole in the cork.

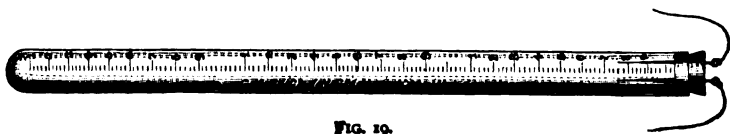

FIG. 19.

This is a very trustworthy method of measuring currents and of comparing batteries. If we wish to ascertain how one battery compares with another in strength, or whether a battery has weakened by use or long standing, or whether the strength is sufficient for a powerful electrolytic operation, the voltmeter will give us precisely the information we seek.

*Galvanometers.*—A galvanometer is an instrument for indicating the presence and direction of a current, and for measuring its strength. There are several varieties of galvanometers, but all are constructed on

ments. It consists of a copper vessel, enclosing a solution of sulphate of copper, a zinc plate, or a sheet of copper folded over a piece of zinc, so as to have *both faces* of the zinc exposed to chemical action, and so increase the quantity of electricity. The two objections to the battery are, that it is not constant, and the metals must be kept out of the solution except when in actual use, and that the zinc becomes rapidly corroded with a deposition that weakens the force of the battery. This deposition must be constantly cleared and scraped off, if we would keep up the strength of the current.

The order of the parts in the sulphate of copper battery, single cell, is as follows : 1st, zinc ; 2d, sulphate of copper ; 3d, copper.

*Reaction.*

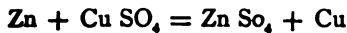

In this battery any local action on the zinc will deposit metallic copper in the form of a black powder upon the zinc, or an oxide of copper, which forms a covering on the surface of the zinc.

For this reason the zinc must be amalgamated or else frequently cleaned. Sulphate of copper must be frequently added, so that the battery shall be charged with a saturated solution of that salt ; but care must be taken that the solution of sulphate of zinc does not approach saturation.

The necessity of frequently cleaning and scraping the zinc in this battery is a most serious disadvantage, and on that account mainly it is not to be recommended to the electro-therapeutist.

*Water Battery.*—If a large number of cylinders of zinc and copper be immersed in water in glass jars, and are properly protected from light and dust, a current of electricity will be produced. A battery of 130 pairs causes the gold leaves of the electroscope to diverge, and 1,200 pairs gives a strong shock. A battery of 2,000 or 3,000 pairs is very powerful. Batteries of this kind have been constructed by Crosse, Noad, and Gassiot.

These water batteries will keep their power for years, provided water is supplied to them to make up for the loss from evaporation. They take up a large space, and, on account of the great resistance of the water, give but a *small quantity of electricity*. For these two reasons they offer no advantage for medical use.

*Marine Battery.*—A sea-water or marine battery has been constructed by Duchemin, of France. A cylinder of carbon and zinc, attached to a cork, is put into the sea, and connected with the shore by con-

ducting wires. As the ocean furnishes the exciting fluid, it needs no replenishing. It was hoped that a battery of this kind might be of sufficient strength to furnish an electric light for light-houses. This hope, so far as we know, has not been realized.

*Dry Pile.*—Dry piles have, instead of liquids, some solid hygrometric substances, as paper or leather. There are many varieties of dry piles. Those of Zamboni, which are best known, are composed of tin or silver and binoxide of manganese. A piece of paper is tinned or silvered on one side, and the other side is covered with powdered binoxide of manganese. These sheets are cut into disks, about one inch in diameter, and arranged so that the tin or silver of each disk is in contact with the manganese of the next in the series. A Zamboni pile of 200 couples is very feeble and slow in its action, but it can charge a Leyden jar, and it is quite permanent.

*Instruments for Measuring Electricity.*—The instruments for measuring electricity are quite numerous, and some of them are very delicate. It is necessary here to describe only a sufficient number to illustrate the principles involved.

*The Voltmeter.*—The voltmeter is an instrument devised by Faraday to measure the strength of the galvanic current. It is a graduated tube that receives and accurately measures the quantity of gas that is generated by the decomposition of water by the current in a given time.

In Fig. 19 the platinum needles connected with the poles of the battery are inserted through the cork, at the end of the tube. The gases that result from the electrolysis rise to the top, as the tube is held upright, and repel the water through a hole in the cork.

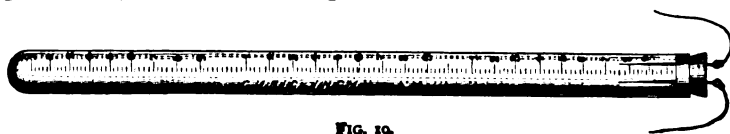

FIG. 19.

This is a very trustworthy method of measuring currents and of comparing batteries. If we wish to ascertain how one battery compares with another in strength, or whether a battery has weakened by use or long standing, or whether the strength is sufficient for a powerful electrolytic operation, the voltmeter will give us precisely the information we seek.

*Galvanometers.*—A galvanometer is an instrument for indicating the presence and direction of a current, and for measuring its strength. There are several varieties of galvanometers, but all are constructed on

the same general principle—a magnet freely hung so as to be deflected by the passage of a current through a coil of insulated wire. Galvanometers with a long coil—sometimes called “*tension*” galvanometers—are used to measure circuits of large resistance. Galvanometers with a short coil—sometimes called “*quantity*” galvanometers—are used to measure circuits of small resistance. The explanation of this difference will appear in the chapter on Ohm’s Law.

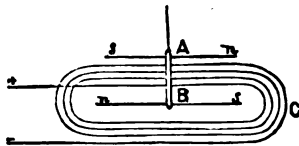

FIG. 20.

*Astatic Galvanometer.*—This form of galvanometer is used either to detect the simple presence of a current, or to measure the strength of a *weak* current. Let A and B, Fig. 20, represent two needles of about equal strength, having the same axis, and having their poles reversed in reference to each other. The needles will settle a very little in the meridian, from the fact that one of them is very slightly more highly magnetized than the other.

C is an insulated wire, bent around the lower needle several times. When a current is passed through this wire, the needles will be influenced to turn in the same direction. In this way the passage of the most feeble current may be detected. In connection with a thermoelectric pile, this instrument is capable of indicating a change of temperature of only a very small fraction of a degree. Galvanometers which have a long resistance coil, and in which a branch resistance coil, or “*shunt*,” as it is called, is interposed, may be used to measure *strong* currents (see chapter on Ohm’s Law), and are therefore convenient in comparing batteries. A galvanometer of this kind that we employ will be described under electro-therapeutics.

*Thomson’s Reflecting Galvanometer.*—Sir William Thomson has done much to advance the science of electrology by the construction of his reflecting or mirror galvanometer, which will indicate the presence of very slight currents. This instrument consists of the coils of a galvanometer, between which are suspended, by a single silk fibre, a mirror and magnet, which, when it moves under the influence of a cur-

rent, is reflected through a lens on a graduated scale placed at a little distance in front of it. A lamp is placed behind the screen, which contains a slit, through which the light passes to the mirror, from which it is reflected back on the graduated scale. When the magnet is deflected by the passage of a current through the coil, the image moves to the right or left along the scale, the angle made by the reflected image being twice the angle through which the mirror and magnet are deflected. *A very small deflection of the magnet produces a very great displacement of the reflected image on the screen, and thus a very slight current can be detected.*

This instrument, as that of Wiedmann, of Germany, is much used in delicate electro-physiological researches.

*Rheostates: Instruments for Measuring Resistance.*—The rheostat, an instrument invented by Wheatstone, was originally designed to ascertain the relative amount of resistance of different conductors. In electro-therapeutics it is employed to interpose resistances in the circuit, etc., so as to delicately modify the strength of the current within small fractions of the strength of an element.

In electro-physiological investigations, as also in certain branches of electro-therapeutics—particularly in applications to the ear—rheostates have been used. The form employed by Brenner and others, and also the water-rheostat, will be described in electro-therapeutics.

*Early History of Galvanism.*—In the year 1786, while Galvani, Professor at Bologna, was experimenting with an old-fashioned electrical machine that lay near a dish of frogs that had been prepared, it is stated, for his sick wife, he noticed that the frogs jumped whenever a spark was drawn from the conductor of the machine. On observing this, it occurred to him that perhaps he had found a means of detecting atmospheric electricity more delicate than he had previously employed. In order to test this, Galvani took the dish of frogs, and, with his neighbor Camillo, went out on the terrace of his house.\* It was a clear evening in the early part of September, and no marked electric phenomena were apparent in the air. Fixing an iron hook in the spine of each frog, he suspended it from the iron railing.

*Behold spontaneous movements appeared in the frogs, various in their character and quite frequent!*

That moment was the birth of the science of Galvanism. At once there flashed on the mind of Galvani the query, *What causes these con-*

\* At No. 96, in Strado S. Felice, Bologna, the house where Galvani lived, with terrace and railings, is still shown to travellers.



*tractions?* There were no electric disturbances in the air; the electric machine was far away inside the house. Could there be electricity in the frogs themselves? In the history of science it often happens that a theory partly false guides us into facts that are wholly true. Thus it happened to Galvani.

From that moment until he died, he lived in an atmosphere of experiment. Frogs without number were slaughtered, and all for the purpose of proving to himself and others that it was *animal electricity* that caused these contractions.

Galvani's researches, as soon as they were made public, in 1791, ex-

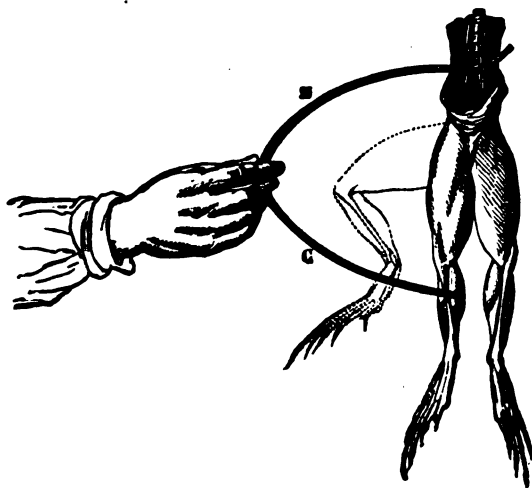

FIG. 21.

cited great interest among scientific men, and inspired him to make another attempt to master the mysteries of electricity. At the time when Galvani made his discovery, the interest excited by the discovery of the Leyden jar and Franklin's kite, about forty years previously, had died out. Philosophers had followed the vein thus opened, about as far as it seemed to lead. They supposed that the battles of electricity were all fought out, and so they were laying aside their armor. On the announcement of Galvani's discovery, his experiments were repeated all over Europe, and the theory that the contractions of the muscles of the frog were due to animal electricity was universally adopted.

*Volta's Researches: The Theory of Contact and Chemical Action.*— Among those who were stimulated by the discovery of Galvani, was

Volta, Professor of Physics in Pavia, Italy, who had already been long distinguished as an electrical experimenter, and who, in the knowledge of this special branch, was far superior to Galvani.

At first Volta accepted Galvani's theory of *animal electricity*, but subsequent research caused him to doubt its truth. He observed that it was only by means of *heterogeneous metals* that muscular contractions could *invariably* be produced, and hence he denied the existence of animal electricity, explaining the phenomenon of muscular contractions through the influence of the artificial electricity excited by a heterogeneous metallic combination.\*

Galvani then not only demonstrated that contractions could readily be caused by exactly homogeneous metals, but that the phenomenon was produced by the simple contact of nerve and muscle. His manner of experimenting was as follows: The leg of a frog, denuded of its skin, had its sciatic nerves cut at their exit from the vertebral column. The nerves thus denuded were taken gently up by some non-conductor and made to touch one of the muscles, when the leg would immediately become convulsed. Volta endeavored to prove that the *convulsion* caused by the contact of nerve and muscle was the cause of the electric current thus produced; but Galvani conclusively demonstrated that such could not be the case, by placing a non-conductor between the two tissues, when no action could be excited in the leg. He went further, and at last succeeded in producing muscular contractions when only the nerves of non-prepared legs were brought in contact.

The discovery of the Voltaic pile, which excited great interest in men of science, seemed to decide the battle for Volta, and all the efforts of Galvani to convince philosophers of the existence of animal electricity were in vain. Galvani's first observations on frogs dates back as far as 1780. He first published his researches in 1791.

Volta did not undertake the investigation of the subject until 1792, the year following the publication of the researches of Galvani. And yet Volta has almost equal claim to be the founder of the science of galvanism; for while Galvani discovered the new manifestation of electricity, he failed to comprehend its true value, while Volta, by the discovery of the pile which bears his name, demonstrated what Galvani would never believe, but which Prof. Fabroni, of Florence, had in 1792 suggested, that chemical action was the source of the electricity in Galvani's experiments.

\* The theory that the experiment of Galvani could be explained by chemical action was first suggested by Prof. Fabroni, of Florence, in 1792.

## CHAPTER IV.

### ELECTROLYSIS (ELECTRO-CHEMISTRY).

ELECTROLYSIS, derived from ἤλεκτρον and λύω, through λύσις, disengaging, *is the act or process of decomposing a compound substance by electricity.*

Electro-chemical decomposition takes place at both poles, but with different products and manifestations, according to the strength of the current, the nature of the substances acted upon, and the material of which the electrodes are composed.

*History of Electrolysis.*—The chemical effects of *statical electricity* were first investigated by Drs. Priestley and Cavendish, in 1784. The decomposition of water by passing through it a succession of discharges of *statical electricity* was first discovered, in 1789, by Messrs. Dieman, Paetz, Van Troostwyck, and Cuthbertson. The power of the *galvanic current* to decompose water was discovered and first described by Messrs. Nicholson and Carlisle, in 1800. They experimented with the voltaic pile, which had then just been discovered. These experiments also decomposed other substances by the galvanic current. On Nov. 20, 1806, Sir Humphry Davy presented to the Royal Society a lecture “On some Chemical Agencies of Electricity,” and in the following year he announced his discovery of the decomposition of the fixed alkalies. Between 1831 and 1840 Faraday published his “*Experimental Researches in Electricity*,” in one of the most remarkable series of scientific essays that ever proceeded from the pen of man.

*Terminology of Electrolysis.*—With the aid of two friends, Faraday prepared the following terminology of electrolysis, which is now generally adopted. The poles where the electricity passes in and out of the body that is undergoing decomposition are called *electrodes* (ἤλεκτρον, and ὁδός, way). The surface where the current enters the decomposing body is called the *anode* (ἀνα, upward, and ὁδός, way); the surface where the current leaves the decomposing body is called the *cathode* (κατά, downward, and ὁδός, way). The *anode* is in contact with the *positive pole* and the *cathode* with the *negative*.

Practically, anode is used as synonymous with positive pole, and cathode with negative, although, strictly speaking, anode and cathode refer to the *points of the decomposing body*, and positive and negative to the *poles of the battery* that are in contact with these.

Compound substances that are directly decomposable by the current are called *electrolytes* (ἤλεκτρον, and λύω, decompose). To *electrolyze* a body is to chemically decompose it by the current. The act of producing electrolysis is called *electrolyzation*.

The elements of an electrolyte are termed *ions*, (εἶων, participle of the verb εἶμι, to go). Those *ions* that appear at the *anode* are termed *anions*, those which appear at the cathode are termed *cations*. Formerly anions were termed **electro-negative**, and cations the **electro-positive** elements of the compound. Water, for example, is an electrolyte that evolves two ions—oxygen and hydrogen; oxygen goes to the anode and is the anion; hydrogen goes to the cathode and is the cation.

No substance can be an electrolyte which is not a conductor; but in the readiness with which they are decomposed substances widely vary. Every electrolyte must contain more or less of water. Pure water, though an electrolyte, is yet decomposed only with great difficulty; but by adding to it a little sulphuric acid, or certain salts, it very easily undergoes electrolysis. It is furthermore believed that no fluid can be a conductor without also being an electrolyte; that is, more or less electro-chemical decomposition must take place when the galvanic current passes through any fluid. Substances that are found to be ready electrolytes are chloride of sodium, muriatic acid, and iodide of potassium.

*Laws of Electrolysis.*—Although electrolysis, like all other phenomena connected with atomic changes, is but imperfectly understood, yet some of the general laws of its operation have been already well ascertained.

Among the more important of these laws the following may be enumerated:

1. *Definite Electro-chemical Action.*—It has been found that when several substances are simultaneously decomposed by the current, the elements that are evolved are definite in quantity and are electro-chemical equivalents of each other. This law, which was discovered by Faraday, may be thus illustrated. Let the current be sent successively through a series of cells filled with oxide of lead, chloride of lead, and chloride of silver. The different substances would combine in the following proportions:

	At the Positive Pole.	At the Negative Pole.
Water.....	8 grs. oxygen.	1 gr. hydrogen.
Oxide of lead.....	8 “	113.5 grs. lead.
Chloride of lead...	35.5 grs. chlorine.	103.5 “
Iodide of lead.....	127 grs. iodine.	103.5 “
Chloride of silver..	35.5 grs. chlorine.	108 grs. silver.

These numbers, it will be seen, represent the combining proportions of these substances.

Substances combine in equivalent proportions ; they are decomposed in the same equivalent proportions.

2. *Primary and Secondary Results.*—The results of electrolytic action are distinguished as *primary and secondary*. The results are called *primary* when the elements that are decomposed appear at the electrodes unchanged and uncombined ; the results are called *secondary* when the elements that are decomposed are changed or recombined when they appear at the electrodes. The secondary results are favored by the *nascent* condition of the elements that are decomposed. The secondary results are caused by the action of the decomposed elements on the substance of the electrode, or on the substance itself that is undergoing decomposition. Even the decomposition of water, when diluted with sulphuric acid, is really a secondary result. Perfectly pure distilled water does not perceptibly decompose even under quite a strong current. If a few drops of sulphuric gases are added, the acids are freely disengaged. The sulphuric acid  $H_2SO_4$  is disengaged by the current into  $H_2$  at the negative and  $SO_4$  at the positive pole ; the former  $H_2$  is liberated, and the latter  $SO_4$  at the positive pole acts on the water and forms sulphuric acid again. Secondary decomposition is modified by the material of which each electrode is composed. Thus in decomposing sulphuric acid, when the positive electrode is made of carbon, the oxygen decomposed acts on the carbon, forming carbonic acid and carbonic oxide. Electro-chemical action continued for weeks, months, and years, as was done by that very laborious experimenter, Mr. Crosse, of Broomfield, may produce as secondary results interesting minerals, such as quartz, arragonite, malachite. During these experiments in electro-crystallization Mr. Crosse discovered that remarkable insect, the *acarus*, which appeared in electrized solutions of sulphate of iron, sulphate of zinc, and nitrate and sulphate of copper. It was supposed that the *acari* arose from *ova* deposited by insects floating in the atmosphere, and that they might possibly be hatched by electric action. As a reward for this discovery, which now seems to be almost forgotten,

Mr. Crosse was subjected to absurd and outrageous abuse, as though he were infringing on the prerogatives of the Creator. Mr. Weekes, of Sandwich, in Kent, subsequently repeated the experiments of Crosse by passing electrical currents through silicate of potash in glass receivers over mercury. All possible care was taken to keep out foreign matter. After a constant action of a year, insects appeared, entirely similar to those obtained by Mr. Crosse. The metallic deposits in electro-metalizing are the secondary results of the electro-chemical decomposition. Water is electrolyzed, hydrogen is disengaged at the cathode, and oxygen at the anode; but the hydrogen reacts on the metallic solution, combines with its oxygen, and frees the metal. The oxygen also combines with an element at the anode. In the section on Electro-Surgery it will be found that the *secondary* decomposition is utilized in the selection of the material used for needles in galvano-puncture.

3. *The Differential Action of the Poles.*—Different elements go to the anode and the cathode, according to the nature of the substance decomposed and the material of which the electrode is made.

*Platinum-wire* makes the best electrode for electrolytic experiments on various substances, because platinum is not acted on. Copper and silver wire may be used, but the secondary action which they cause greatly complicates the experiment.

To distinguish the precise character of the changes that take place in the electrolysis of many substances is frequently difficult, and sometimes impossible. It is difficult to decide whether any of the elements of the electrolyte, besides water, undergo decomposition; and whether the changes are of a primary or secondary character.

Among the substances that are most readily decomposed by the electric current are the following:

*Iodide of Potassium.*—This decomposes under a very feeble current, the iodide and oxygen going to the positive and the hydrogen and alkali to the negative. Thus the decomposition of iodide of potassium by electricity affords a very good means of distinguishing the poles. The brown color of the iodine always appears at the positive pole. The whole solution soon presents the color of iodine.

*Chloride of Sodium.*—A solution of common salt decomposes quite readily, chlorine appearing at the positive and hydrogen and oxide of sodium at the negative pole. If the positive needle is platinum, the odor of chlorine is at once detected; if it is of copper, the chlorine unites with the copper, making the solution turbid.

*Acetate of Lead.*—This salt in solution decomposes with comparative slowness by secondary action, peroxide of lead appearing at the posi-

sive pole, and hanging from it in light threads or masses. The water frequently decomposes before the lead yields at all.

*Nobilis Iris-Rings.*—It is by the electrolysis of lead that the beautiful iris-rings are produced. A polished steel plate is put in a dilute solution of acetate of lead. The steel plate is connected with the positive pole of a galvanic battery, while a wire, connected with the negative pole, is put in the solution. Peroxide of lead is at once liberated on the steel beneath the wire, and a film extends outward, but growing thinner and thinner. Thus a series of concentric circles is formed exhibiting bright iris colors.

*Nitric Acid.*—Strong nitric acid conducts well and decomposes, oxygen appearing at the positive pole, nitrous acid and nitric oxyd at the negative pole. Dissolution takes place, and the water becomes yellow.

*Nitrate of Potash.*—This is a good conductor, and yields secondary results.

*Sulphurous Acid.*—This, when diluted, yields oxygen at the positive pole, and hydrogen and sulphur at the negative.

*Sulphuric Acid.*—This yields sulphur at the negative pole, and produces secondary results.

*Muriatic Acid.*—A strong solution of this yields hydrogen at the negative pole, and chlorine at the positive pole.

*Electro-metallurgy.*—Electro-metallurgy, or the art of precipitating metals from their solutions by the galvanic current, is a result of the discovery of electrolysis—is indeed itself simply an electrolytic process. There are two divisions of this art—electrotyping and electroplating. The art of electro-metallurgy was discovered, independently, by Spencer, in England, and Jacobi, in Petersburg, in 1837. Electro-gilding was discovered by Brugnatelli, a pupil of Volta, but was first used by M. de la Rive.

*Theory of Electrolysis.*—The theory of electrolysis at present accepted is the following: In every compound one of the elements is electro-positive, the other, electro-negative. Under the influence of the opposing electricities from the electrodes, decomposition and recombination go on from one pole to the other. But these decompositions and recompositions are seen only *at the electrodes*.

This may be illustrated by the electrolysis of water. Water is composed of one atom of oxygen and two atoms of hydrogen. Oxygen is electro-negative and hydrogen is electro-positive.

When, now, the electrodes are dipped in water, the electro-negative oxygen of the molecule *a* (Fig. 22) is attracted to the positive pole, and the electro-negative hydrogen is repelled.

The oxygen is then given off at the positive pole, while the liberated hydrogen unites itself with the next atom of oxygen of the molecule *b*, while the original atom of hydrogen is expelled.

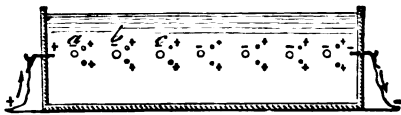

FIG. 22.

This atom of hydrogen unites with the oxygen of the molecule *c*, drives out the hydrogen with which that atom had been previously combined, and so on through the whole series of molecules until the negative pole is reached. Here the hydrogen has no more oxygen to combine with, so it is liberated as gas.

The electrolysis of all other electrolytes is similarly explained. This simple and ingenious theory was devised by Grothüss.

*Decomposed Elements appear only at the Electrodes.*—In electrolysis the elements decomposed appear only at the electrodes; the intermediate region presents no change, although, of course, it must be traversed by the decompositions that occur. This is illustrated by the following experiment of Davy: Three vessels are connected by a cotton wick thoroughly moistened. In one vessel is placed an alkaline salt, and in the other two, water. The liquid of all three vessels is colored with syrup of violets. When the galvanic current is made to pass through the vessels, the liquid at the negative pole becomes *green*, and the liquid at the positive becomes *red*, demonstrating that the acid goes to the positive and the alkaline base to the negative pole. The fluid in the *middle vessel* suffered no change of color, although it must have been traversed by the acid in the solution.

*Electrolysis compared with the Reactions in the Batteries.*—It will be observed that the chemical action that takes place in the fluids of any battery is similar to electrolysis. The two are, indeed, facts of precisely the same nature. The action in the battery is accompanied by an electric current; the action in electrolysis occurs as a result of the passage of a current.

In the section on Electro-Surgery it will be shown that all these physical laws of electrolysis have a direct and necessary bearing on the use of electrolysis in surgery.

VANDERBILT



## CHAPTER V.

### INDUCED ELECTRICITY—CURRENT AND MAGNETO-INDUCTION—ELECTRO-MAGNETISM—THERMO-ELECTRIC BATTERIES.

*Induced Electricity, or Electro-Magnetism: Electro-dynamical Induction.*—We have seen that *induction* means the action that electrified bodies exert on other bodies at a distance. Electro-static induction has already been treated of. We have now to speak of the induction of current-electricity.

Prof. Oersted, of Copenhagen, first observed that the electric current, brought near a magnetic needle, caused it to deflect. This was the earliest observation in electro-magnetism.

Philosophers at once set themselves at work to explain this phenomenon. The discovery was not an accidental one on the part of Oersted. For years he had been occupied with the study of electro-physics, and as early as 1807 he had published a work in which he stated that he purposed to ascertain whether electricity in its most latent state had any effect on the magnet. His first discovery that the needle had a tendency to place itself at right angles to the wire in which a current was passing, was a natural sequence and confirmation of his early researches. This discovery by Oersted formed another era in the science of electricity; for in 1820 the enthusiasm caused by the discoveries of Galvani and Volta had subsided, just as the enthusiasm caused by the Leyden jar and Franklin's kite had died away when Galvani made his renowned experiment.

*Ampère's Theory of Magnetism.*—Among the many scientists who sought to explain and unfold the phenomena of electro-magnetism as discovered by Oersted, it was reserved for Ampère to achieve the highest success. This theory, which was developed by rigid mathematical demonstrations, was, that *each molecule of a magnetic body is traversed by closed electric currents*. These currents are free to move about their centres of gravity, but the *coercitive force*, which is weak in soft iron but great in steel, tends to keep them in position.

Before a magnetic body is magnetized these molecular currents, or rings of electricity, by their mutual attraction neutralize each other, so that their combined action on any other substance is nothing.

When a body is *magnetized*, these *molecular currents assume a parallel direction*. The more complete the magnetization, the more nearly parallel they become. When they are completely parallel, the limit of magnetization is reached. Ampère further supposes that all these molecular currents are equivalent to a *single current* circulating round the magnet. Still further, and in consonance with his theory, Ampère supposed that terrestrial magnetic effects were due to magnetic currents that circulate round the earth from east to west, perpendicular to the magnetic meridian. The resultant of these currents is a single current going from east to west. These currents, which are supposed to be due to the action of the sun, deflect magnetic needles, magnetize iron, etc.

*The Electric Current acts as a Magnet: Solenoids.*—In confirmation of Ampère's theory of magnetism, it is found that when a helix, or spirals of covered wire, coated in such a way that one of the wires passes through the axis (solenoid, as it is called), is suspended into cups of mercury, and traversed by a current, it will act like a *magnetic needle* and point from north to south. Ampère gave the following rule by which the directions of the needle under the current can be understood: Let the observer imagine himself placed in the wire, so that a current enters at his feet and leaves at his head, while his face is turned toward the needle; the pole will always be deflected *toward the left of the observer*.

*Helix.*—In a helix of a copper wire through which a current circulates, *each convolution of the spiral* may be regarded as one of the little magnets of Ampère's theory. The ends of the spiral, when the current passes through it, act on a magnetic needle like the poles of a magnet. Ampère's theory explains two important magnetic phenomena.

1st. Why like poles repel and unlike attract.

Two north poles of a magnet side by side have opposite currents and repel each other. Similarly with two south poles. But a north and south have currents in the same direction and attract each other.

2d. Why a magnetic needle places itself north and south. A magnet can come to rest only when the current below it, nearest the earth, is parallel to the earth-current. The magnetic needle turns to the north to allow the currents below it to become parallel to the earth's current.

*Electro-magnetic Helix.*—Magnetism is induced in a bar of soft iron by the simple passage of a current near it, in a direction at right angles to the bar. If, however, the wire (Fig. 23) encircles the iron many times, this effect will be much increased. Let a current be passed over the wire in the direction of the arrows, and the iron within will become strongly magnetic, with its poles as shown by the letters S and N. If the enclosed iron be not too heavy, it will be drawn to the centre and held suspended there.

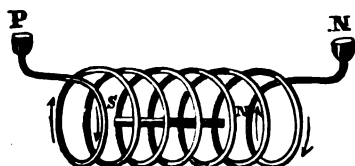

FIG. 23.

When the current is broken, the iron ceases to be magnetic; while, if a bar of hardened steel be substituted for the iron, it will retain its magnetism permanently. Such a coil of wire is called a helix, from  $\chi\lambda\zeta$ , a winding, and a magnet formed in the manner described is termed an *electro-magnet*.

Fig. 24 represents the general form of an electro-magnet. It is composed of a bar of soft iron, bent into the form of a horseshoe. An insulated wire is coiled round its extremities. When a current of electricity is passed through the coil, the horseshoe-bar becomes magnetic, and attracts the armature. If the current is broken, the bar becomes demagnetized and the armature falls to the ground. Permanent magnets possess much less power than electro-magnets.

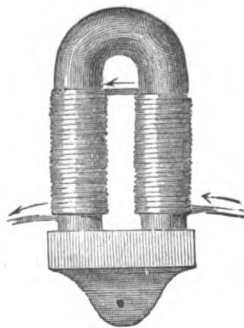
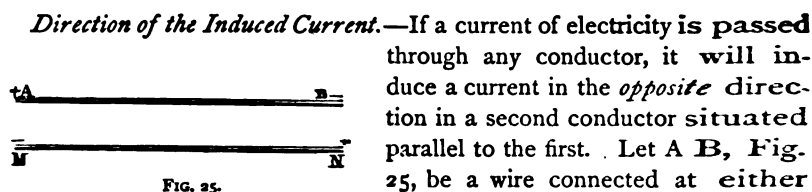

FIG. 24.

If the iron bar within the helix be more than a third of an inch in thickness, and the current be of moderate strength, the magnetism induced is in proportion to the strength of the current, and of the number of turns in the coil. Additional coils of the wire give no increased magnetism, if the bar is thinner than one-third of an inch. In this case maximum is soon reached. Again, if the circuit is made very long, thus reducing the strength of the current, the advantage usually gained by the thick bar, and by increasing the number of coils, may be lost. The iron bar should be perfectly pure and well annealed, in order that the electro-magnet may quickly acquire and as quickly lose its magnetism on closing and breaking the circuit.



This current is, however, but for an instant. As soon as the circuit is broken, an instantaneous current, with its direction reversed, is again established in the second wire.

*Different Orders of Induced Currents.*—Induced or secondary currents have themselves the power of producing induced currents in other adjacent circuits. Currents thus induced from secondary induced currents are called tertiary induced currents. These tertiary induced currents have also the power of producing induced currents in an adjacent circuit, and so for a long series.

Currents produced in this way are in opposite directions alternately, and their strength diminishes the higher they ascend.

As a secondary current flows in a direction opposite to that of the battery current, so the *tertiary* flows in a direction opposite to the secondary. This law holds good throughout the whole series,—the strength of the current diminishing as the distance from the battery increases.

The manifestation of electrical action in the secondary coil, upon closing and breaking the circuit, is called the *electric throb*, while the passive condition of the wire while under induction has been described by Faraday as *electro-tonic*.

If the primary coil be movable, so that it can be brought in closer proximity to the secondary coil while the current is passing, an inverse current is produced at the moment of its approach, the same as when the circuit is closed. If now the primary coil be withdrawn, a direct current is produced, the same as when the circuit is broken. As long as the primary coil remains in one position, all evidence of electricity in the secondary wire disappears. If, however, while in this position, the strength of the primary current be increased or diminished, momentary currents are established in the secondary coil; the inverse following the increase, and the direct current following the decrease in

the strength of the primary current. In thus experimenting, it is much more convenient to wind the wires on separate bobbins, so that one may be placed within the other, as represented in Fig. 26.

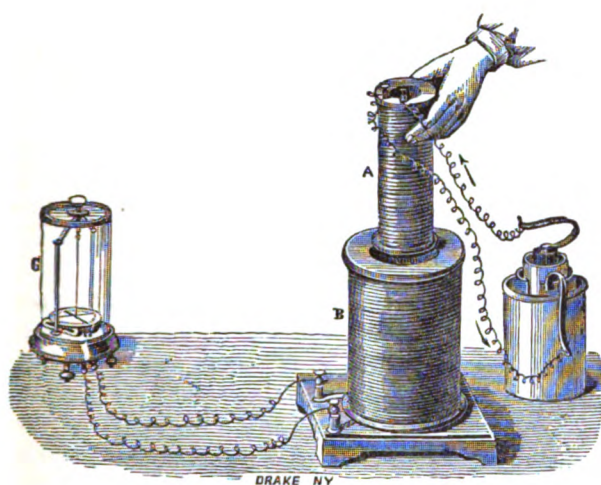

FIG. 26.

Let A represent the primary coil, which is composed of wool-covered wire  $\frac{1}{2}$  of an inch in diameter; and B the secondary coil, of silk-covered wire, much longer than the other, and about  $\frac{1}{8}$  of an inch in diameter. Now let the secondary coil be connected with the galvanometer, G, by means of the two binding-screws, while the primary coil, by two loose and flexible wires, is placed in the circuit of a galvanic cell. As soon as A is inserted into B, a momentary inverse current is indicated. If it be withdrawn, the galvanometer indicates a momentary direct current. While the primary coil remains in the secondary, the needle announces the induction of currents according to the principles stated above, whenever the strength of the primary current is increased or diminished.

*The Conditions under which Induction takes place.*—To sum up in brief. Induction takes place from one circuit into an adjacent circuit, 1st. At the moment when the current is closed. 2d. The moment when the current is opened. 3d. While the current is increasing or diminishing in strength. 4th. While the current is brought near to or removed from the adjacent circuit. A current that closes or increases

in strength, or is brought near to an adjacent circuit, induces an *inverse* momentary current in that circuit. A current that opens or diminishes in strength, or is removed from an adjacent circuit, induces a *direct* momentary current in that circuit. It will be seen, therefore, that induction takes place only when there is some *change in the condition of the inducing current*. It must be closed or opened, increased or diminished in strength, brought near to or removed from the adjacent circuit.

In the ordinary electro-magnetic machines these changes are made by a *rheotome*, or current-interrupter, and the strength of the current is modified by withdrawing or removing a metallic cylinder enclosing the coils, or by withdrawing or removing the core of iron needles.

*Induction of a Current on Itself: Extra Current.*—The extra current is that which is induced by the current in each coil, or winding of the primary coil on the other adjacent windings.

The windings act inductively on each other both at the opening and closing of the circuit. Thus we have a direct and an inverse extra current. The direct extra current gives shocks and sparks, decomposes water, magnetizes steel, and melts platinum-wire. The electro-motive force of the extra current bears a uniform relation to the intensity of the primary or inducing current. When the *secondary* coil is *closed*, the extra current does not appear in the primary coil, but by what is called reaction it is formed in the secondary coil itself, and becomes an ordinary induced current.

It is called the extra current only so long as it remains in the *primary* coil; it so remains only when the *secondary* coil is *open*.

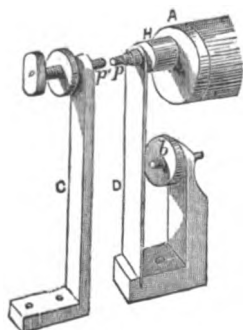

FIG. 27.

*Rheotome, or Current-interrupter.*—Among the different contrivances for producing these changes in the primary current that are necessary for induction, the most convenient is the Rheotome, or *Current-interrupter*.

This, when placed in the circuit of the primary coil, alternately *closes and opens the current*, and thus causes induced currents in the secondary coil.

Fig. 27 represents a current-interrupter.

Into the iron covering A are fastened the ends of the iron wires of the core within the coil.

The hammer H is attached to a spring D, which is in the primary circuit; *p* is a projection tipped with platinum, because that metal does not corrode; *p'*, connected with the

screw, is also tipped with platinum. When the circuit is closed, the core of iron-wire A becomes magnetic, and draws H away from  $p'$ , against which it naturally rests. This breaks the current, for the circuit is completed through the connection of  $p$  and  $p'$ . As the current is broken, A of course loses its magnetism, and no longer has power to attract H; therefore the spring D brings H back to  $p'$ , where it naturally rests. This completes the circuit, and again A becomes magnetic, and again it attracts H, and thus H is *kept rapidly* vibrating with a buzzing sound between A and  $p'$ . These constant interruptions keep up an induced current in the secondary coil. The screw  $b$  gives the necessary stiffness to D.

*Object of the Iron Core in the Primary Coil.*—The inductive power of the primary current is very greatly increased by putting a bar of soft iron or a bundle of iron wires in the heart of the primary coil. The iron core strengthens the current in this way. It becomes magnetic by the action of the current, and this magnetism disappears when the current opens. The disappearance of the magnetism induces a current in the *same direction* as the disappearing primary current, and thus strengthens it. In electro-magnetic machines, as used for electro-therapeutics, this iron core is a very convenient means for modifying the current. Pushing it in the coil increases the current, withdrawing it diminishes the current.

A bundle of wires is preferable to a single bar of soft iron, for in the latter, currents are formed which impede the sudden cessation of the primary current, while in the former these cannot be formed.

*Thickness and Length of the Outer and Inner Wires.*—It is a law of electro-physics that wires of a large diameter conduct electricity better than wires of a small diameter. It is necessary that the primary current should be strong, since its principal object is to excite magnetism in the core; consequently the coil is made of thick wire and of moderate length. The secondary coil, however, is made of very thin wire, and of great length, so that as many turns as possible may be brought within the influence of the core and of the primary coil, and thus produce a secondary current. As with the galvanic or inducing current, the electro-motive force of the battery is proportionate to the number of cells; so with the induced or secondary current, the electro-motive force of the coil is proportionate to the number of turns or coils in it.

*Induction Coils and Electro-magnetic Machines.*—An induction coil for philosophical or electro-therapeutical purposes consists usually of *two helices or coils of wire enclosing a bar of soft iron or a bundle of*

*iron wires.\** The *inner* coil is connected with the poles of a **battery**, and there is some arrangement for breaking the current. The *inner* coil is composed of tolerably coarse wire, and is comparatively **short**. The current that runs through it is called the *primary*, or sometimes the *inducing*, current. The outer coil is in no way connected with the inner coil, but receives by *induction* a current from the current of the inner coil as it is alternately broken and closed. The *outer* coil is composed of *fine* wire, and it is very much longer than the inner coil.

The finer and longer the wire, the greater the tension of the current. The current that comes through the outer coil is called the *secondary* current, in distinction from that which comes from the inner coil, which is called the *primary*. In both coils the copper is insulated with silk covering.

*Ruhmkorff's Coil.*—The most powerful of all coils, and the one best adapted for philosophical experiments, is that of Ruhmkorff, of Paris. It is about 14 inches in length. The inner coil is of copper, is about 2 mm. in diameter, and 4 or 5 yards long. It is coiled on a cylinder of card-board, and is enclosed in an insulating cylinder of glass or rubber.

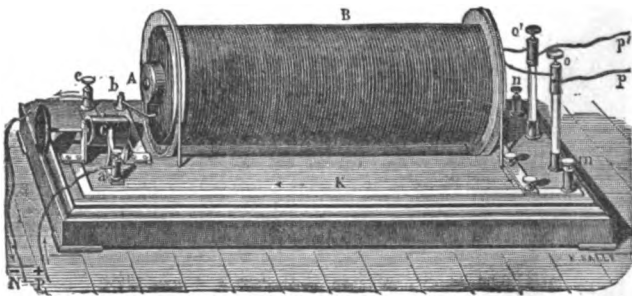

FIG. 28.

The wire of the outer coil is of copper, from  $\frac{1}{8}$  to  $\frac{1}{4}$  mm. in diameter, and from *thirty to sixty miles in length*. The distinctive features of this coil are these :

1st. It is coiled in sections so as to avoid the induction of the outer coil on itself, which is liable to take place when it is very long and the tension is high, however thorough the insulation.

\* In the machine of Kidder, to be described under Electro-Therapeutics, the helix is composed of three or more coils of wire, not distinct, but connected.



2d. The insulation is very complete. The wire is covered with silk, and each winding is separated from the others by a layer of shellac. In the larger coils of Ruhmkorff the induced currents are thousands of times stronger than the primary current that excites them.

*The Condenser of Ruhmkorff's Coil.*—The intensity of the current of the secondary coil is increased by interposing a condenser in the circuit. In Ruhmkorff's coil the condenser consists of 150 sheets of tin-foil 18 inches square, and with a surface of about 75 square yards. These sheets are coiled around insulating oiled silk, and around each other, so as to form two armatures, and the whole is placed below the helix in the base of the apparatus.

Being introduced into the circuit, it receives the extra current and increases its tension. It stores up and utilizes force that would otherwise be wasted in the form of sparks at the interrupter.

*Effects produced by Ruhmkorff's Coil.*—The tension of Ruhmkorff's coil is enormous, and for the reasons above given—the length and fineness of the secondary wire and the power of the condenser. It possesses all the properties of *statical* as well as *dynamical* electricity. It is capable of giving a shock so violent as to prostrate a man, and if a sufficient number of elements are connected with it, it could kill as by a stroke of lightning. When two couples are connected with it, it will kill a rabbit. It causes fine iron wire to melt and burn with a bright light. It can rapidly decompose water, or produce luminous effects in the water without decomposition.

It decomposes and combines gases. Passed through a hermetically sealed tube containing air, it forms nitrous acid from the nitrogen and oxygen. It can produce a spark eighteen inches in length in the air.

In *vacuo* it produces most remarkable effects. In the so-called *electric egg*, a luminous trail is observed between the poles. At the positive pole the light is red and brilliant; at the negative, feeble and violet. If vapor of alcohol, or turpentine, or bisulphide of carbon, be introduced into the vessel, it appears in the form of alternate light and dark zones or strata. The tints vary with the nature of the vapor. The same phenomena are obtained by the ordinary galvanic current from a large number of cells. The luminous effects of the coil are as great from a single cell as from a large number.

In electro-therapeutics a wide variety of electro-magnetic machines have been devised. Most of them are run by one or two cells, like Smee's or Walker's, and the current generated is just sufficient for application to the human body, and are but little adapted for the philosophical room.

The largest induction coil of which we have any knowledge is that of Apps, in London. It is nine feet ten inches long, and its diameter is two feet. The soft-iron core is five feet long, four inches in diameter, and weighs 125 pounds. The length of the primary coil is 3,770 yards, while that of the secondary coil is *one hundred and fifty miles*. This battery is excited by 48 large Bunsen cells. It gives a flash twenty-nine inches long that will perforate five inches of solid plate-glass. At the Stevens Institute of Technology, Hoboken, there is also an induction coil of great power.

*Properties of Induced Currents.*—Induced currents have in different degrees all the properties of the ordinary galvanic current. They produce chemical, thermic, luminous, and physiological effects. They deflect the magnetic needle, magnetize steel, and are capable of themselves exciting induced currents. There is a difference, however, between the effects of the *direct* induced and *inverse* induced. The direct gives a powerful shock, the inverse a mild shock.

The direct magnetizes to the point of saturation, the inverse does not magnetize.

In their action on the galvanometer they are about equal. In quantity, the direct and inverse induced currents are about the same; but the tension of the direct induced is greater than that of the inverse induced.

*Comparative Chemical Effects of the Galvanic and Induced Currents.*—That the chemical character of currents of induction is distinctive from the galvanic is proved by the following experiment: When the platinum poles connected with an induced current are placed in water, water is decomposed and oxygen produces oxidation of platinum, which is reduced to metallic platinum by the recombination of the hydrogen with the oxygen. This process takes place at both poles, so that both become covered with a powder of platinum.

If a solution of iodide of potassium and starch is brought into the circuit, the *blue* color appears at *both* poles. When the galvanic current is used, the blue color appears only at the positive pole. When the induced current is sent through water it decomposes it, just as the galvanic current does the oxygen and hydrogen, both appearing at *both* poles; but they recombine, and thus the water does not appear to be decomposed at all.

It is of the first importance to the electro-therapeutist to understand electro-magnetism, for it is the form of electricity most used in electro-therapeutics.

*Magneto-electricity.*—Magneto-electric induction is the induction of

electric currents by magnetism. It is, as the term implies, the reverse of electro-magnetic induction. There are two forms of magneto-electric induction.

The *first* and most familiar form is when a current is induced in a coil of insulated wire. The *second* form is when a current is induced in conducting plates.

Under electro-magnetic induction we have seen that the coil of wire in which a current circulates produces a contrary induced current in an adjacent coil whenever a change is made in the current by opening, closing, withdrawing, or approaching it. The strength of the induced current is proportioned to the amount and suddenness of these changes. If now we substitute for the primary or inducing coil a permanent *bar magnet*, and cause it to approach or withdraw from the adjacent coil, it induces a current in that coil. This principle is the basis of all the magneto-electric machines that are so familiar to students of philosophy, and that were once so much used in electro-therapeutics.

The development of magneto-electricity is shown in a very simple manner by the common horseshoe magnet, its armature, and a copper wire. Let the armature A B be encircled by the wire C, one end of which is flattened and amalgamated with nitrate of mercury, and the other filed to a point. When the armature is placed upon the magnet, the moment of contact, when it is withdrawn, and the act of withdrawal, will each be marked by a spark of electricity at C, where the two extremities of the wire meet.

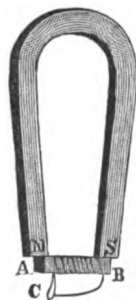

FIG. 29.

The electric current flows in one direction at the instant magnetism is induced in the soft iron which is enclosed by the coil of wire, and in the opposite direction when its magnetism is destroyed.

In the electro-magnetic machines in ordinary use a soft-iron armature covered with wire is made to rotate in front of the poles of a permanent horseshoe magnet. As the armature rotates, its two ends are, of course, alternately brought near to and removed from the bars of the magnet, and thus two currents are induced in the wires that cover the armature. Each current lasts half of a revolution, and if the rotation be rapidly kept up, a current is produced which may be perceived when the ends of the wires are joined.

*A Continuous Current from Magneto-electric Machines.*—When the armatures of the magneto-electric machine are made to revolve with

sufficient rapidity, a *continuous* current is produced which has all the properties of the galvanic current. Magneto-electric currents are, therefore, extensively used in electrolytic experiments and in electroplating. It is possible that some of these may be utilized in electrotherapeutics.

*Currents induced by Magnetism in Conducting-plates: Magnetism of Rotation.*—In 1824–5 Arago discovered that when a copper disk revolved with great rapidity under a needle resting on a disk above the disk, the needle deflected in the direction of the motion of the disk. After a time, if the movement be sufficiently rapid, the needle refuses to remain fixed, and turns around after the disk. The explanation of this phenomenon was given by Faraday in 1831. He showed that it arose from the *reaction* of the currents induced in the plate by the magnet. The magnetism of rotation is only one of the many phenomena connected with induction. All these phenomena—induction by currents of magnetism and by rotation—are explained by the theory of Ampère before cited. They are at once in harmony with that theory and confirmatory of it.

*History of Induction.*—The discovery that electric currents of magnetism can induce currents in neighboring circuits was made by Faraday in 1830. His researches on the subject were published in the Philosophical Transactions in 1831 and 1832.

This discovery of Faraday, like that of Oersted, was the result, not of accident, but of long and laborious experimentation. As early as 1825 Faraday had sought to make a wire, through which the galvanic current was passing, induce a current in a neighboring wire, just as a conductor charged with Franklinic electricity would have done. Not until 1831 did he find out that the current must be broken or closed, or approached or withdrawn, before it could induce a current in a neighboring wire.

In 1832 Prof. Henry, then of New Jersey, now of the Smithsonian Institute, Washington, observed phenomena which, in 1834, Faraday showed were due to the extra current. In 1837 Bachhoffner and Sturgeon showed that a bundle of wire was better in an induction apparatus than a rod of soft iron.

In 1841 Prof. Henry studied the inductive action of currents on currents. In 1850 or 1851 Ruhmkorff constructed the induction-coil, and in 1853 Fizeau greatly increased its power by adding to it a condenser. The discovery that discharges of the Leyden jar made a primary spiral induce a current in a secondary spiral, and that currents of the third, fourth, and fifth order can be thus produced, and of suffi-

cient strength to give shocks, burn, etc., was made simultaneously by Profs. Henry, of Washington, and Riess, of Berlin.

The first magneto-electric machine was made by Faraday in 1831. The first machine of the style now used was made by Pixii in 1832. Improvements have been since made by Saxton (1833), Clarke (1836), Petrine (1844), Stöhrer (1844), Siemens, Halske, Duchenne, and others.

#### THERMO-ELECTRICITY.

*Thermo-electricity is that form of electricity that arises from the heating of two heterogeneous conductors at their junction.* The two most important methods of generating thermal currents are, 1st, with two portions of the same metal; and 2d, with two different kinds of metal.

*Thermo-electricity generated by One Metal.*—If a copper wire be cut into two pieces, and one of the ends be heated to redness and pressed against the end of the other piece, a current of electricity is produced. This is demonstrated by the galvanometer.

When different portions of the same metal have different structures, a current is obtained when the point where both structures come together is heated.

If, for example, a platinum wire be twisted or bent on itself, this twisting so changes the structure of the wire that a current is generated by heating the point of union between the twisted and non-twisted portion.

*Thermo-electricity generated by Two Metals.*—Let A and B (Fig. 30) be respectively bars of antimony and bismuth, soldered together, while G represents a galvanometer connected by two wires with the free extremities of the metals.

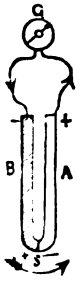

HEAT  
FIG. 30.

When the junction S of the metals is heated, a current of electricity is generated, which flows from the bismuth to the antimony, as shown by the arrow. If the junction S is chilled by applying ice, a current is also produced, but in the opposite direction. This combination constitutes a *thermo-electric pair*.

*Thermo-electric Batteries.*—A number of thermo-electric couples soldered together so that the copper or antimony of one is soldered to the bismuth of the other, and so on, is called a *thermo-electric battery*. The current is generated by heating one row of the soldered faces, or, as the current depends on the *difference* of temperature of the two sides, by applying ice to one side and heat to the other.

The accompanying cut represents Farmer's thermo-electric battery, constructed on the principles above indicated. The heat is supplied by a gas-burner or alcohol-lamp.

Thermo-electric batteries of any form are not as yet much used in electro-therapeutics. The hopes at one time entertained of them have

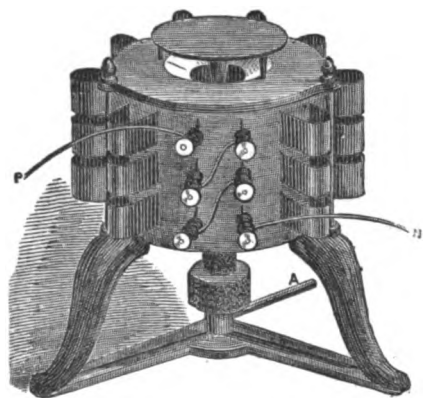

FIG. 31.

Farmer's Thermo-Electric Battery.

been disappointed. In practice they have been found to be inconvenient, bulky, expensive, and untrustworthy. It is not impossible, however, that future researches may so develop the department of thermo-electricity that thermo-electric batteries may be constructed that shall be more convenient for practical use than the ordinary galvanic batteries. This is a realm in which there is room for experiment.

## CHAPTER VI.

### OHM'S LAW AND ITS PRACTICAL APPLICATION TO ELECTRO-THERAPEUTICS.

THE basis of all electrical measurement is Ohm's law, which is, that the *quantity of electricity passing through any point in a circuit varies directly as the electro-motive force, and inversely as the resistance.*

Putting Q for quantity, E for electro-motive force, and R for resistance, the law is thus expressed:  $Q = \frac{E}{R}$ .

This law was discovered by Prof. Ohm, of Nuremberg, in 1827, and for a long time was neglected. It is the north-star of dynamical electricity. Those who can keep this always in sight need never lose their way, however long or intricate the explorations they may make in this important and fascinating realm. Although originally nothing but a theory, yet it has been powerfully confirmed by the mathematical calculations of Fechner, Pouillet, Kohlrausch, Daniell, De la Rive, and Wheatstone, and has proved itself competent to explain all the phenomena with which it has to do. Just as the strength of the theory of gravitation consists in its power to account for the movements of the solar system, just as the strength of the undulatory theory consists in its power to explain the complex phenomena of light, so the strength of Ohm's law consists in its power to account for the phenomena of dynamical electricity. As no one can be master in astronomy without understanding gravitation, or in optics without understanding the undulatory theory, so no one can be master in electricity without understanding Ohm's law.

We shall endeavor to make this law and its application as clear as the nature of the subject will allow. It is necessary to define certain terms that are not very familiar; first of all, *units of measurement.*

A *unit* is an abstract term to express any *determined quantity, by the repetition of which any other quantity of the same kind can be measured.*

An *ohm* is a unit of resistance; one million ohms = one megohm; one millionth of an ohm = one microhm.

A number of units of resistance have been proposed—among others,

definite lengths of wires of a definite thickness; but wire is rarely pure, and the different specimens widely vary.

In 1864 the British Association, acting on the suggestion of Weber, decided that electrical resistance could be expressed as an absolute velocity, without any reference to the substance that conducts. This unit, which expresses a velocity of 10,000,000 metres in a second, is called a *B. A.*, or *British Association, unit*.

Previous to this action of the Association the best known units were those of Siemen and Varley. *Siemen's unit* is a column of pure mercury, one metre long and one square millimetre in sections at  $0^{\circ}$  C. *Varley's unit* was one mile of ordinary copper-wire, No. 16,  $\frac{1}{8}$  of an inch in diameter at  $60^{\circ}$  F. The *B. A. unit* of the British Association is embodied in an alloy of platinum and silver. This alloy has the advantage of German silver, that its conducting power does not change with long use.

The unit of *electro-motive force* is called a *volt*. A volt is equal to about the force of a Daniell cell, or the decimal '9268.

The unit of quantity is a *farad*. In other words, a farad is the quantity of electricity which, with a certain electro-motive force, flows through a certain resistance.

The terminology of electricity in general has been atrociously difficult and obscure, but nowhere has there been deeper obscurity and grosser misunderstanding and inconsistency than in the application of the terms *resistance*, *quantity*, *tension*, and *electro-motive force*.

*Electro-motive Force*.—The *electro-motive force* is the force that urges forward the current.

It is the origin of *tension*, to be hereafter defined. This force is modified—

- 1st. By the nature of the plates of which the element is composed.
- 2d. By the nature and strength of the acid solution.
- 3d. By the number of elements in the solution.

Substances that stand at or near the two *extremes* of the electro-positive and electro-negative series, generate a stronger electro-motive force than substances that stand near each other.

Zinc and platinum or zinc and carbon give more electro-motive force than zinc and copper, because the difference in their oxidability is greater, and they stand farther apart in the electro-positive and electro-negative series.

Plates that are imperfect in their structure, or which contain impurities that generate currents in opposition to the main current, or plates that are worn out, or are encrusted with the products of chemical



decomposition, give less electro-motive force than plates that are perfect, fresh, and clean.

Similarly also the electro-motive force is diminished by the *polarizing* action of the current in the cell. Thus, in the Smee cell, the hydrogen that gathers on the platinum-plate and the oxygen that gathers on the zinc, generate a current that is opposite in direction to the main current, and enfeebles it; and for this reason, lifting the plates out of the liquid a moment to allow the gases that form on them to escape, or vigorously agitating the liquid, at once increases the electro-motive force. Strong acids which excite vigorous chemical action give more electro-motive force than weak acids, and therefore it is that sulphuric and nitric and chromic acids are so much used in batteries.

When the proportion of acid in the solution is large, electro-motive force is greater than when it is small. Strong solutions, however, consume the plates faster, and the electro-motive force will be reduced thereby sooner, other conditions being the same, than when weak solutions are used.

The electro-motive force is exactly proportioned to the *number of elements*, without regard to their *size*. Two elements give twice as much electro-motive force as one element, and one hundred elements give one hundred times as much as one element of a similar character. This can be proved by a galvanometer, with a long resistance-coil, where the deflection of the needle will be in pretty exact proportion to the number of cells brought into the circuit. The exactness of this proportion is of course modified by the imperfections of individual elements, or by variation in the quantity and strength of solution in each cell; but the law always holds good.

As with the long-coil galvanometer, so with the human body, or any other powerful resistance whatsoever, the electro-motive force that passes through it will be—all other conditions being the same—proportioned to the *number of elements and without regard to their size*. If a series of very *large* elements are opposed to an equal series of very *small* elements of similar construction, no current will pass; they will neutralize each other. If both be tested by the galvanometer with a long resistance, they will cause similar deflections of the needle.

*The quantity of electricity that passes through a circuit is directly proportioned to the electro-motive force.* If there were no resistance in the circuit, quantity and electro-motive force would be the same:  $Q = E$ . But there can be no circuit without some resistance, therefore  $Q$  never equals  $E$ .

Electro-motive force of different batteries, approximately :

Grove.....	100
Bunsen.....	98
Daniell.....	56
Smee (when not in action).....	57
“ (when in action).....	25
Wollaston (copper and zinc).....	46
Marié Davy (sulphate of mercury and graphite). . .	76
Chloride of silver.....	62
Chloride of lead.....	30

These estimates are the mean of a very large number of observations by Latimer Clark, taken on a sine galvanometer. The electro-motive force is somewhat modified by various undetermined causes.

*Tension, or Potential.*—*Tension is that quality of electricity by which it overcomes resistance.* This definition is practical rather than strictly scientific, and can only be understood by explanation.

Tension is a *result* of the electro-motive force, and is dependent on it, and by mistake the two are often confounded. The sum and the differences of electro-motive force are always equal to the sum and differences of tension, but they are differently distributed in the circuit. By mathematicians the term *potential*, suggested by Green, is preferred to tension. The term is a *relative* one, and no body or part of a body can be said to have an *absolute* tension or potential. The potential of a body is really the difference between its potential and that of the earth, which is assumed to be zero. Electricity flows from a body or part of a body at a higher potential, to a body or part of a body at a lower potential, and the work which it does measures its amount. Differences of potential may be compared to differences of level for water. As water tends to flow from a higher level to a lower level until all is of a uniform height, so electricity tends to flow from a higher to a lower potential until the potential of all parts of the conductor is the same, and ceases to flow. An instance of extreme tension is found in lightning, where it is caused by the differences in the electro-motive forces between two clouds, or between the clouds and the earth.

The tension of the frictional machine is very great, for the reason that it is not at all influenced by the resistance of the circuit, which in the galvanic battery is very great. If the current of the galvanic battery encountered no resistance in the circuit, or was not affected by resistance, its tension would be enormous.

The term *intensity* has long been used as synonymous with tension; but, strictly speaking, intensity is derived from the French *intensité*,

which has been translated intensity, but which really means *quantity*. It is better to dispense entirely with the term intensity, and we have done so in the present work.

Our definition of tension may be thus illustrated: Let a battery of 100 cells be joined in the ordinary tension arrangement, zinc united with carbon and so on. Place the battery on an insulated stand, and connect the zinc or negative pole with the earth, leaving the other free. Regarding the earth, for convenience' sake, as zero, the copper pole will have a tension of 0, while the free end will have a tension of 100 *positive*. If a wire be connected with the free end, a current would flow *from it* to the earth. If now we reverse the position of the poles, connecting the carbon pole with the earth, and leaving the other free, the carbon end will be 0, and the zinc end will be 100 *negative*, and if it be connected with the earth a current will flow *from the earth* to it. In both of these cases the tension is the same; in one case it is positive, in the other negative. Take the same battery, with the zinc pole connected with the earth, and join the carbon and zinc ends by a short, thick wire, and a strong current will flow through the wire. But here comes in the difference between tension and electro-motive force, for it can be ascertained by proper tests that the electro-motive force of the battery is the same as it was before the ends were joined, but the tension has changed. Before, it was 100 positive at the carbon end, now it is almost 0.

If, instead of a short, thick wire, a long, fine wire that offers greater resistance be used to connect the poles, the tension at the carbon end will rise with the increase in resistance in the wire. When the resistance becomes infinitely great, the tension becomes 100 again, but it can never exceed 100, for the tension can never *exceed* the electro-motive force at any point, although it may fall very much below it.

These two general laws in regard to tension should be remembered:

- 1st. It rises with the distance from the zero end of the circuit.
- 2d. The quantity of electricity passing between any two points is always proportioned to the *difference* of tension between these points. The actual tension may be high or low, positive or negative, but there can be no current without *differences* of tension.\*

The *arrangement* in series (or, as it is erroneously called, "intensity arrangement"), is when the electro-positive element of one cell is united to the electro-negative element of the next cell, and so on. The "quantity arrangement," or "*multiple arc*," is when all the electro-positive ele-

\* *On Electrical Measurement.* By Latimer Clark. London, 1868, p. 17.

ments are united to all the electro-negative elements so as to **make one large element**. The arrangement in series, or a "tension arrangement," is used for all ordinary galvanization and electrolyzation. The multiple arc, or "quantity arrangement," is used in galvano-cautery. The phrases "joined for tension," or "intensity," and "joined for quantity," are relics of old and exploded theories of electricity. For convenience' sake they are still used ; but those who understand Ohm's law need not be deceived by them.

*Resistance.*—Resistance is that quality of a conductor that *impedes the passage of a circuit*.

There are two kinds of resistance in any circuit :

- 1st. That of the battery itself (*Internal Resistance*).
- 2d. That of the connecting wires (circuit outside of the battery), the galvanometer, the human body, or other substance introduced into the circuit (*External Resistance*).

*How Resistance is Modified.*—Resistance is modified in three ways :

- 1st. By the nature of the substance, whether liquid or solid, or by its special chemical composition.
- 2d. By the form of the substance, whether long or short, of small or large diameter.
- 3d. By the temperature.

It is proved by experiment that *the resistances of wires of the same material and of the same thickness are directly proportioned to their length, and inversely proportioned to the squares of their diameters*.

A wire one mile in length gives twice the resistance of a wire half a mile long, and four times the resistance of a wire one-fourth of a mile long. On the other hand, wires of the same metal, but of diameters which stand to each other in the relation 1, 2, 3, offer a resistance which stand to each other as 1,  $\frac{1}{4}$ ,  $\frac{1}{9}$ . In other words, the longer the wire the *greater* the resistance, the thicker the wire the *less* the resistance. The same law, but less exactly, applies to liquids, and for this reason *large elements give less resistance than small elements*. The relative specific resistances of a number of metals at a temperature of 54° F. are as follows :

Copper.....	1	Iron.....	7.5
Gold.....	1.4	Lead.....	11
Zinc.....	3.7	Platinum.....	11.3
Mercury (at 57°).....	50.7.		

The converse of resistance is *conduction*.

The following table of the relative conductivity of metals at 32° F

is taken from Latimer Clark. It will be perceived that it varies somewhat from the above table of relative resistances :

Silver .....	100	Zinc.....	29
Copper (pure).....	99.9	Steel .....	16
“ selected (commercial)....	85 to 95	Iron .....	15
Copper, ordinary (commercial).....	40 to 70	German silver.....	12 to 15
Brass.....	20	Tin .....	12.4
Gold.....	78	Lead .....	8.3
		Platinum.....	6.9
		Mercury.....	1.6

It will be seen that both estimates agree in making copper and silver the best conductors, and for that reason copper-wire is so much used in making battery connections. In both tables platinum stands low in conductivity, and for that reason platinum-wire is used when, as in galvano-cautery, it is required to generate heat by passing the current through a *resisting* medium. If mercury could be made in the form of a wire it would of course be better than platinum, since its resistance is somewhat greater. *Bismuth, graphite, and coke* rank still lower in conducting power than mercury. The resistance of liquids is enormous. Thus, taking copper-wire at 32° F. as 1, the resistance of a saturated solution of sulphate of copper at 48° F. is 16.885.520; ditto of chloride of sodium at 56° F., 2.903.538; ditto of sulphate of zinc, 15.861.267; sulphuric acid diluted to  $\frac{1}{10}$  at 68° F., 1.032.020; nitric acid at 55° F., 976.000; distilled water at 59° F., 6.734.208.000.

It has been estimated that the human body, by virtue of the salts which it contains, conducts 15 or 20 times better than water, provided the skin be fully moistened; and that copper conducts from three to four hundred million times better than the human body.

*Effects of Temperature on Resistance.*—Resistance is more or less modified by temperature.

Between 1° and 100° C. the relative conducting power of the metals remains the same; at 100° metals lose about 30 per cent. of their conductivity as compared with 0° C.; but this varies with different metals. Conductivity is increased by annealing. Non-metallic substances increase in conductivity as they rise in temperature. Water, for example, when heated conducts better than water cold. When a current passes from a liquid to a solid, or *vice versa*, the resistance is very great.

*All Resistance relative.*—No substances *absolutely* resist the passage of electricity; even resin, glass, and sulphur, the worst conductors, do conduct a slight current, as can be proved by a very delicate galvanometer.

*No perfect Conductor.*—Even the best conductors, as copper and silver and gold, are imperfectly so; they all resist the current more or less.

This can be shown with the galvanometer, which, when brought *directly* into the circuit, shows a deflection of the needle. When short wires of copper or silver are interposed the deflection is lessened.

If we now comprehend the terms *electro-motive force* and *resistance*, we shall have no difficulty in comprehending the term quantity, for, according to Ohm's law, the quantity varies directly as the electro-motive force and inversely as the resistance.

*The quantity of electricity is the amount which passes through the circuit in any given time.*

This depends, according to Ohm's law, on two factors—the *electro-motive force* and the *resistance*. The quantity *varies directly* as the *electro-motive force*; and if there were no resistance, quantity would be precisely the same as electro-motive force. But the *quantity varies inversely as the resistance*, and therefore, to find out what the quantity of any current is, we *divide the electro-motive force* by the resistance. The fraction thus formed is the quantity or the *strength* of the *current*, as we commonly call it. There are, as we have seen, two kinds of resistance, that in the battery and that in the circuit outside of the battery; *both of these* must be taken into account in estimating the relation of the different kinds of batteries, and in selecting batteries for special kinds of work. Let E be the electro-motive force, R the resistance of the circuit outside of the battery, r the resistance in the battery;

then  $\frac{E}{R+r} = Q$ , the quantity or strength of the current—the number of farads or measures of electricity that flow through the circuit in a given time. The correctness of this mathematical conclusion may be demonstrated on a galvanometer that has only a short resisting wire; one cell will deflect the needle nearly as much as one hundred cells. Again, *when any number of cells are joined together with great external resistance, such as is offered by a long, fine wire, or by the whole human body, for example, the quantity of electricity that flows through the circuit will increase with the increase in the number of cells.*

There is no inconsistency between these phenomena. It is indeed a part of and a conclusion from Ohm's law. Everything depends on the

*external resistance.* Although in this case, as in the other, each added cell brings in its own internal resistance that counterbalances the electro-motive force, yet the internal resistance *bears so small a proportion* to the large external resistance that the quantity of electricity flowing through the circuit will be pretty directly proportioned to the number of cells.

Still keeping Ohm's law before us, we can demonstrate this mathematically.

Let the electro-motive force of any cell be 10 volts, and the *internal* resistance be 20 ohms, and the *external* resistance afforded by the *human body* 10,000 ohms. The quantity of a single cell could be thus represented :

$$\frac{10 \text{ electro-motive force}}{20 \text{ internal resistance, and } 10,000 \text{ external resistance}} = \frac{10}{10,000} = \frac{1}{1000}$$

Again, we may illustrate this as follows :

One hundred cells are joined together and the ends are connected by a short wire. Let the electro-motive force of one cell be 10 *volts* or units of electro-motive force, then the electro-motive force of 100 cells will be 1,000 volts. Let the resistance in each cell be 5 *ohms*, or units of resistance, then the resistance in the 100 cells will be 500 ohms. Let the resistance of the short connecting wires be 10,000 ohms : now, in order to find the number of *farads* of electricity—that is, the quantity or strength of the current that flows through the connecting wire—*divide the electro-motive force by the resistance*, and we have this fraction :

$$\frac{1,000 \text{ electro-motive force}}{10,000 \text{ resistance of wire, and } 500 \text{ resistance of battery}} = \frac{1,000}{10,500}$$

This fraction reduced =  $\frac{2}{21}$ , a little more than  $\frac{1}{10}$ , which fraction represents the quantity of electricity that flows through the wire.

We may illustrate this law by supposing a current of water passed through an ordinary syringe. The quantity of water that flows through the tube will be directly proportioned to the force with which it is urged forward by the piston ; this force would correspond to electro-motive force. The friction will correspond to the internal and external resistance of the battery. Now if we divide the one by the other, we have the quantity of water which in a given time flows through the tube, or the strength of the current. In this way we can find the number of cubic inches of water that flow through the tube in a second of time, just as we can find the number of farads, or units of

quantity of electricity, that flow through a circuit. It follows from all this, of course, that if the electro-motive force be very greatly increased, the resistance being the same, the quantity must be increased; but if the resistance be increased in proportion to the increase of the electro-motive force, the quantity will not be any greater.

*Absolute Quantity and Actual Quantity.*—It also follows that the *absolute* quantity of any battery—the amount that it is capable of generating—may be very much greater than the *actual* quantity that it sends through a circuit. Everything depends upon the *resistance*, whether it be small or great.

*Relation of Quantity to Electro-therapeutics.*—It is important to know how to ascertain the *quantity* of electricity, for nearly all of the leading actions of electricity depend on quantity. It is quantity that deflects the needle of the galvanometer, and quite accurately measures the current that passes through the wires that surround the needle. It is quantity that decomposes chemical substances, as water, salts, the human body, etc. Hence, electrolytic operations largely depend on the quantity of electricity that flows through the tissues acted on. It is quantity that accomplishes much of the therapeutical effect of the different forms of electrization—although tension alone, with very small quantity, may, as in the case of frictional or franklinic electricity, be capable of therapeutical effects. Franklinic electricity, however, relieves and cures disease by changing the electrical condition of the patient, by giving a positive or a negative charge, more than by the passage of the current through the body, and the consequent electro-tonic and chemical changes. Ordinary faradic or galvanic electricity, on the other hand, does not, as many suppose, charge the patient with electricity, and does not, by its *direct* action, leave any more electricity in the body than it finds there. If they increase or diminish the natural electricity of the body, it is indirectly through the effect of quantity of electricity passing through the tissues and improving nutrition.

Under this head come these important practical conclusions:

*First. If any large number of cells every way similar are joined in a SHORT CIRCUIT by large connecting wires, and without any other external resistance, there will be no more quantity of electricity flowing than if a small number of similar cells were so joined.*

Although each additional cell increases the electro-motive force, yet it also increases the resistance, as we have already seen, and this increase of resistance will counterbalance the increase of electro-motive force, so that the quantity of electricity that flows through the circuit



will be about the same. Ohm's law will demonstrate this mathematically. Let the electro-motive force of any cell be 10 volts, or units of electro-motive force, and the resistance of each cell be 20 ohms, or units of resistance, and the resistance of the short wire 2 ohms. Dividing the electro-motive force by the resistance, we have for a single cell  $\frac{10}{20} + \frac{2}{20} = \frac{12}{20} = \frac{3}{5}$  = the quantity that one cell sends through the circuit.

Now let there be 50 similar cells, and our fraction will be  $\frac{10}{20} \times \frac{50}{50} = \frac{500}{500} + \frac{2}{500} = \frac{502}{500} = \frac{251}{250}$  = a fraction that varies very slightly in value from  $\frac{3}{5}$ . Let there be 1,000 cells, and we have this fraction:  $\frac{10}{20} \times \frac{1000}{1000} = \frac{1000}{1000} + \frac{2}{1000} = \frac{1002}{1000}$ . The result still differs but slightly from those previously obtained.

*Secondly. Large cells connected by great external resistance, as the human body, or a galvanometer with a long resistance-coil, do not send more quantity of electricity through that external resistance than similar small cells.*

The electro-motive force of large cells is no greater than that of similar small cells, as we have already seen. The *resistance* is less because the surface of the plates is greater, and the greater the section the less the resistance, as has already been shown. But the little advantage thus gained from large cells by a diminution of resistance bears so *small a proportion to the great external resistance* of the human body, or of a very long wire, that the quantity of electricity actually sent through the circuit will not be materially increased—at least by any reasonable number of cells.

Here again Ohm's law comes to our assistance, and fortifies our statement by a rigid mathematical demonstration. Let us suppose a battery of 100 *small* cells. Let the electro-motive force of each cell be 10 volts. Let the *internal* resistance of each cell be 20 ohms. Let the external resistance of the human body, through which the current is to be made to pass, be 10,000 ohms. Now, by Ohm's law, to find the quantity of electricity that flows through the human body when enclosed in the circuit, we divide the electro-motive force by the internal and external resistance, as follows :

$$\frac{100 \times 10 = 1000}{10,000 \text{ (external resistance), } + 100 \times 20 = 2000 \text{ (internal resistance)}} = \frac{1000}{12000} = \frac{10}{120} = \frac{1}{12}$$

Let us now suppose 100 similar very *large* cells. The electro-motive force would be the same, the *external* resistance would be the same. But the *internal* resistance of the battery would be *less* because the surface is greater.

By a law previously explained, the *resistance varies inversely as the square of the section*. For convenience sake, we will suppose the resistance of the large cell to be  $\frac{1}{10}$  that of the small ones—that is 2—and Ohm's law will give us the following fraction :

$$\frac{100 \times 10 = 1000 \text{ (electro-motive force)}}{10,000 \text{ (external resistance)}} \div \frac{1000}{100 \times 2 = 200} = \frac{1000}{10000} = \frac{10}{100}$$

—a fraction that is, it is true, a little larger than  $\frac{1}{10}$ , but not enough to be worth considering.

The same truth may be shown by a galvanometer that has a long resistance-coil. If the fluid be raised just a little, so that elements are just immersed and the poles are connected with such a galvanometer, a certain deflection of the needles will take place, according to the number of cells ; if now we raise the fluid still higher, so that all the elements are immersed, and four or five times as much surface is brought into action in each cell, the needles will not be much more deflected, but will remain at nearly the same point where it was when the elements were first immersed. This is an experiment that we have made repeatedly.

For the galvanometer substitute the human body from the hand to the legs, and we can understand the great fact that large cells do *not* send more *quantity of electricity through the body than small cells of similar character*.

From all these demonstrations we see that it is with electricity as with money—the *absolute* quantity that any man may give may be a very small fraction of the *actual* quantity that he *can be made* to give. A millionaire has a far greater quantity of money than one who has only a thousand dollars, but the one may not give a dollar any easier than the other. Under great pressure the millionaire may give a thousand times more than the poor man, just as a battery of large cells may, before small resistance, send a very much larger quantity of electricity than a similar battery of small cells ; but when there is great resistance it may send very little, if any, more.

In electro-therapeutics, as in telegraphy, electro-metallurgy, and other uses, large cells have this advantage, that *they last longer and do not require so frequent cleaning and filling*.

Although they cannot in a given time send through the human body, or long lines of wires, any more quantity of electricity than small cells, yet their *reserve* quantity is much greater, and in proportion to their size *they will hold out longer and keep up a more uniform current*. The poor man may give five dollars as easily as the millionaire, but

under great pressure the millionaire can keep on giving out five dollars long after the resources of the poor man are exhausted.

Large cells may, for electro-therapeutical purposes, have the advantage of *steadiness* of current ; there would appear to be less *fluctuation* in the strength of the current from moment to moment than when the cells are small.

In small cells the degree of the internal resistance and the extent of the chemical action may vary more or less from moment to moment, owing to the polarization of the elements and the deposition of the salts in the solution. This fluctuation is most marked in batteries where the action is very energetic. Small single cells, especially the zinc-carbon batteries, lose much of their power during a long operation. *The popular notion that large cells have a therapeutic advantage over small cells by sending a larger quantity of electricity through the body is, in the light of Ohm's law, as well as in the light of experience, erroneous.*

*Thirdly. For the electro-chemical decomposition of water, salts, and the human body (electrolysis), a considerable number of cells of medium size, neither very large nor very small, and in which the chemical action is powerful, are required.*

The resistance of the *limited portion* of the human body usually submitted to electrolytic operation is great, though not so great as that of the whole body ; and as we have seen, before a *great resistance*, very large cells give no greater quantity in a given time than cells of moderate size. If the cells are too small, however, they will soon become exhausted. For electrolytic operations, the ordinary zinc-carbon or Walker's batteries, as manufactured in this country by the Galvano-faradic Manufacturing Co., Kidder and others, answer very excellently most of the purposes of electrolysis. They have more electromotive force than Smee's elements, and although not as enduring, they yet give a greater quantity of electricity for a *short* time, which is of course the great requisite in electrolytic operations. The resistance of the skin is very great, but in electrolysis the needles go beneath the skin, and are placed near each other. The resistance is very much less than in external applications when the electrodes are far apart ; hence it is an advantage in electrolysis to have cells of good size, though not of the largest.

*Fourthly. When a short platinum-wire in a short circuit is to be heated, as in galvano-cautery operations, a very few large cells or a single very large cell is preferable to a large number of small cells.*

This fact has long been practically recognized, and all the batteries

for **galvano-cautery** operations are constructed on this principle. The reason for this is not so well understood; Ohm's law gives us the explanation.

Platinum-wire, though it resists the current very powerfully as compared with silver or copper wire, yet offers a very small resistance as compared with water or the human body, or *very long* wire of any kind. Hence, in the galvano-cautery instruments, the *external* resistance is small, being not very much greater than the internal resistance of the batteries, perhaps not so great. Now, before a large external resistance—the human body, or very long coils of wires—the surface of the elements is used to the best advantage when cut up into small cells; before a small resistance, the surface of the elements is used at the best advantage when cut up into a few large cells, or, if the external resistance be very slight indeed, a single large cell will be better; for we have previously shown that, in a short circuit, one cell gives as much quantity of electricity as one hundred, or, indeed, any number of cells.

Let us suppose 100 small cells; let each cell have an electro-motive force of 10 volts and a resistance of 20 ohms. Let there be enclosed in a circuit the human body, or a very long coil of fine wire, that gives a resistance of 10,000 ohms. Then, according to Ohm's law, we have the following fraction:

$$\frac{100 \times 10 = 1000 \text{ electro-motive force}}{10,000 \text{ external resistance } + 100 \times 20 = 2000 \text{ internal resistance}} = \frac{1}{20}$$

which represents the quantity of electricity that flows through the circuit. Suppose now one *cell* of the same character, but very much larger, sends a current in a short circuit—through a *short* platinum-wire, such as is used in the galvano-cautery for cauterizing surfaces. Suppose the external resistance of this short circuit be 9 ohms. The electro-motive force of the large cell is no more than that of the small cell; the internal resistance of the battery is very much less, for, as we have seen, the resistance diminishes as the surface increases. For convenience sake, we will suppose the internal resistance of the large to be  $\frac{1}{10}$  that of the small cell—that is, 1. Now, dividing the electro-motive force by the resistance, according to Ohm's law we have this result:

$$\frac{10 \text{ electro-motive force}}{9 \text{ external resistance } + 1 \text{ internal resistance}} = \frac{10}{10} = 1$$

the quantity of electricity that flows through the circuit, or **twelve times** as much as with 100 small cells.

Suppose now this one large cell be connected by a *long and fine* platinum-wire, such as is used in the removal of tumors by galvano-cautery operations. The resistance will of course be greater, for two reasons, because the wire is longer and because it is finer; for the law is, the less the surface or section the less the resistance.

Suppose the resistance be 19 ohms. Dividing the electro-motive force by the resistance, we have—

$$\frac{10 \text{ electro-motive force}}{19 \text{ external resistance} + 1 \text{ internal resistance}} = \frac{10}{20} = \frac{1}{2}$$

*that is, one-half the quantity of electricity that there was when a short platinum-wire was in the circuit.* Very likely this would not be enough to heat the wire and keep it hot during a long operation. This law comes to our rescue, and helps us out of this as of so many other difficulties. Cut up the one large cell into two cells, and interpose the long fine platinum-wire in the circuit. The electro-motive force will be doubled, the external resistance will be the same; but the internal resistance will be greater because the surface is diminished.

Dividing the electro-motive force by the resistance, our fraction stands thus :

$$\frac{20 \text{ electro-motive force}}{19 \text{ external resistance} + 4 \text{ internal resistance}} = \frac{20}{23}$$

which is nearly double the quantity of electricity sent through the long wire by a single cell. Thus is explained the fact that the best galvano-cautery batteries are arranged so as to be thrown into one large cell, or cut up into several cells, according as a short or long wire is to be heated.

*It has been found by experiment that the heat developed by the current in any wire is proportioned to the squares of the quantity of electricity that flows through it.*

This is demonstrated by passing a current through platinum-wires in a bottle of alcohol. The heat is communicated to the alcohol, and the thermometer shows the temperature. It is found if a current of a certain quantity raises the temperature 10, a current of twice that strength will raise it 40.

*Again, it is found by experiment that the heat developed by the current in any wire is proportioned to the resistance of the wire.*

This is demonstrated with the arrangement just described, by inserting a rheostat whose resistances are known, so as to keep the quantity

of electricity constant at a fixed point, and then inserting platinum wires of different lengths into the bottle.

From all this it follows that batteries for galvano-cautery should have large surfaces and a small number of cells, and that they should be arranged so that the surface may be used as one or two cells, or cut up into four or six, according as short or long wires are to be heated.

*Fifthly. It follows that the dose of an electrical application cannot be accurately described by stating the number of cells and the length of the sitting.*

This conclusion is an important one, and for want of a knowledge of it electro-therapeutists continually blunder.

Supposing now that we are treating a patient locally or centrally by the galvanic current, and we desire to transfer the patient to another physician. We inform the physician to whom the transfer is made, that we are treating the patient with ten cells for ten minutes, and we desire that he should continue to give the same dose. In the light of Ohm's law, let us see what such instructions are really worth. The quantity of electricity that passes through the patient in a minute is equivalent to the electro-motive force divided by the resistance; multiply the quotient thus obtained by ten, and we have the dose of electricity that the patient receives in ten minutes. If, now, all the factors that determine the electro-motive force and the external and internal resistance were constant and were accurately known, and if they were the same for all batteries and all modes of application, then the dose thus ordered would be a mathematical one, and could be mathematically followed. No forms of error are so erroneous or so illusory as those that approach us under cover of facts and figures. In our very attempt to be accurate we stumble into gross inaccuracy. Had we left the whole matter to the judgment of the physician, with some general suggestions as to the susceptibility of the patient, we should have come far nearer the truth, as will be apparent by the following considerations.

The electro-motive force varies in different batteries, and in the same battery at different times. Grove's battery, for example, has four times the electro-motive force of Smee's battery in action, and twice the electro-motive force of zinc and copper, or Daniell's battery. Then, again, the electro-motive force will, in some batteries, as Smee's or Walker's, fall off during an application; and in all batteries, however constructed, the electro-motive force varies at different times, from causes not yet determined.

But the electro-motive force is constancy itself in comparison with

the variations of the internal and external resistances. Beginning with the internal resistance, we find that for a Grove's cell, containing one pint of liquid, it is very small, less than one ohm; for a Daniell's cell, 5 to 15 ohms, and for a Smee's cell, less than one ohm. The internal resistance varies with the size and shape of the cell, the distance of the plates from each other, and with the length of time that the battery is in action. Even if the electro-motive force and external resistance were accurate and constant, the variations in the internal resistance would be sufficient to vitiate all attempts at prescribing electricity by the number of cells.

But it is in the external resistance that we find the greatest variation, uncertainty, and inconstancy in applications of electricity to the human body. The external resistance depends on the following factors:

1st. The size and construction of the wires that connect the battery with the electrodes. The larger the section the less the resistance, and, therefore, large wires will conduct more than small ones. A certain conventional size is manufactured by each instrument-maker, but the sizes vary with different makers.

2d. The size and shape of the electrode. Up to a certain point, varying with the number of cells, a large, broad electrode will conduct more than a small and narrow one. A metallic electrode conducts very much better than a sponge; flannel conducts much better than sponge, but worse than metal. The difference in the conducting power of metal, sponge, and flannel, is great. A current which is painful when applied by a metal, and is quite perceptible when applied by a flannel or chamois, is not felt at all when applied by a sponge. The painfulness of an application, it is true, does not depend on the amount of electricity that passes, but is also modified by the extent to which the current is diffused. This would depend on the action of the electrode. With the same current passing, the hand of the operator would probably be less irritating than a sponge or flannel.

3d. The quantity and quality of the liquid used to moisten the electrodes. Electrodes that are perfectly dry conduct but little, at least with currents of the tension used in electro-therapeutics. Electrodes that are wet with warm water conduct better than those that are wet with cold water; and those that are wet with warm salt-water conduct best of all. The difference in the conductivity of a sponge wet with simple cold water and one wet with warm salt-water is so great that a current which is not felt when applied by the former, becomes unbearable when applied by the latter.

4th. The amount of pressure that is used on the electrodes. If the

wet sponge is lightly pressed it conducts but little, and its conductivity increases with the pressure. Firm pressure moistens the skin more thoroughly, and thus increases its conductivity, and at the same time it brings into coaptation all parts of the sponge, so that it becomes well saturated.

5th. The position and extent of the body included between the electrodes. This factor is a most important one, and it has been unaccountably overlooked in all discussions on this subject. The difference in the conductivity of the bones and soft tissues is all the difference between twenty and one, and in all parts the conductivity is modified by age, by temperament, and by disease. The resistance of the whole body, from one hand to the other through the shoulders, is about seven or eight times the resistance of the Atlantic cable, and the resistance of the whole length of the body, from the head and shoulders to the feet, is probably greater than that. But the resistance of any limited portion of the body, as the head, or spine, or cervical sympathetic and pneumogastric, or individual muscles or nerves, must be only a fractional part of the resistance of the whole body. Other conditions being the same, the nearer the electrodes are to each other the less the resistance. This may be illustrated by an experiment that we have frequently tried. If one electrode be put in the vagina and the other in the rectum, a current of but two or four cells may be painfully felt; but if one of the electrodes is placed externally on the back or hypogastrum, a current of a dozen or more cells may be scarcely perceived. The same experiment may be tried on the back; placing one pole on the nape of the neck and the other at the lower end of the spine, a current that is just perceptible at first, as the electrodes approach each other becomes positively unbearable.

6th. The length of the application. When the galvanic current is first applied to the body by wet sponges, but little sensation is experienced on the skin; but in the course of a few seconds a burning pain is felt, that increases with the length of the application. This is explained in part by the chemical changes that take place, and in part by the fact that as the skin becomes more and more moistened by the pressure of the wet sponge, and the skin under the electrode becomes more and more congested, the resistance is diminished. Consequently, toward the close of even a very short application, more electricity passes, all other conditions being the same, than at the beginning. On this account it frequently becomes necessary to reduce the number of cells during the sitting, especially when the electrodes are kept all the time on one spot. Thus it becomes clear that any attempt to prescribe the



dose of electricity by the number of cells, in ordinary *external* applications to the body, must fail of its object. In electrolysis, where the needles are always united, near to each other and under the skin, the chances for error are not so great, since there is much less variation in the resistance. If, in describing an electrolytic operation, we specify the *kind* and number of cells used, and the mode and length of operation, we convey a tolerably correct idea of what was really done. The time may come in the advance of science, after physiology shall have found its Newton to reduce its present chaos to order and law, when it shall be possible to prescribe so many *farads* of electricity, repeated three times a week, as we now prescribe so many grains of bromide of potassium, or so many drops of laudanum, repeated three times a day; but for the present we can rest assured that when we describe the current that we employ as *mild*, or *medium*, or *strong*, and have stated the method and length and frequency of application, we have attained all the accuracy that science will allow.

Although the above statements have reference only to the galvanic current, they just as truly apply to the faradic; for induced as well as galvanic electricity is subject to the law of Ohm. One difference, however, should be noted, that on account of the slighter chemical action of the faradic current the resistance of the skin beneath the electrodes does not diminish with the length of the application. For the above reasons the graduated scales that accompany some of the faradic machines for electro-therapeutics are of but little practical value.

Finally, Ohm's law explains the fact of observation, that when the poles of a galvanic battery are metallically connected, the chemical action in the battery is greatly increased and the plates rapidly destroyed. The metals being better conductors than the body, conduct a much greater quantity of electricity; and as the potential quantity of electricity that any battery is capable of generating is limited, then when the resistance between the poles is least, the action must be strongest, and the metals the most rapidly consumed. Neglect in this regard causes the premature destruction of many batteries.



# **ELECTRO-PHYSIOLOGY**



## CHAPTER I.

### RELATION OF ELECTRO-PHYSIOLOGY TO ELECTRO-THERAPEUTICS— ANIMAL ELECTRICITY.

*Electro-physiology is the science which treats both of the laws of animal electricity, and also of the phenomena produced by the action of electricity on the body in health.* We propose to present this subject as compactly as possible, and consequently shall speak only of those facts that are necessary for a true appreciation of the science, and chiefly of those that, directly or indirectly, have a practical bearing on electro-therapeutics.

*Importance of a Knowledge of Electro-physiology to the Electro-therapeutist.*—It is of course possible to use electricity successfully in therapeutics without any thought of its physiological action, and thousands have so used it. It is possible to relieve pain of almost every variety, and to cure any of the curable forms of paralysis, without understanding anything of the action of electricity on nutrition or on the normal muscle. Any old country granny, the stupidest of nurses, an infant even, can hold two sponges on a part of the surface of the body, and let the current run. Those who aim no higher than this—the indiscriminate holding of electrodes on patients—need give no thought to electro-physiology; need, indeed, waste no time on this or on any other work of electro-therapeutics: they do not even need to trouble themselves with the details of the applications, but have simply to delegate them, without reserve, to the nearest nurse or clodhopper. Those, we assert, who aim no higher than this will fall short of even that: their success in relieving symptoms by electrization will be so capricious and illusory, that, in time, they will abandon the attempt, allow their battery to grow rusty in the garret, and thenceforth they will condemn and despise scientific and successful electro-therapeutists.

The electro-therapeutist, above all others, should start out under the inspiration of the motto of the late President Dwight: "Aim high, for you will be sure to come short of your aim." To apply electricity after the manner of nurses and "rubbing doctors," is not using it, but abusing it.

Those who aspire to mastership in electro-therapeutics will not be content with the mere attempt to relieve symptoms ; they will seek to study those most complex and subtle diseases for the treatment of which electricity is indicated ; they will resort to this force for diagnostic as well as therapeutic aid ; they will strive to know not only how to use it, but, what is more difficult, how not to use it. He only can reap the full and rich harvest of electro-therapeutical science and art who sows beside all waters ; he must become more or less proficient in neurology, in electro-physics, and in electro-physiology. He who has a knowledge of the laws of animal electricity, and the actions and reactions of franklinic, galvanic, and faradic electricity on the brain, spinal cord, and sympathetic ; on the nerves of motion and of common and special sense ; on voluntary and involuntary muscles ; on the skin, and on all the various passages and organs of the body in health, and also of the electro-conductivity of the body, will find the paths of electro-diagnosis and of electro-therapeutics illumined at every step by such knowledge, and will, in the end, make more correct interpretations of disease than he who merely holds electrodes on patients without any higher aim ; and more than that, he will be introduced into a field of thought and experiment—a field surpassingly rich and fruitful, and lying in close relation to all departments of physiology, of pathology, and of biology, where he can study science for its own sake, without regard to its immediate practical value.

In the above remarks we do not wish to be understood as subscribing to the notion, quite popular among some, that electro-therapeutics must be based on electro-physiology ; very far from it : the two sciences are closely related and are of reciprocal assistance, but one is not built up on the other. Neither are exact sciences, and may never become such. Pathology, though it is but “the shady side of physiology,” yet so complicates therapeutics that electro-physiology cannot become a reliable basis for electro-therapeutics. The two sciences are pursued mainly by different methods : electro-physiology is a science of experiment ; electro-therapeutics is a science of experience.

*Electro-physiology largely Studied by Experiments on the Living Human Subject.*—An advantage of great import to electro-physiology, and one that especially commends it to the electro-therapeutist, is that it is largely based on experiments made on the living human subject. True enough, thousands of frogs have given up their lives in the electro-physiological laboratory, and dogs and cats, rabbits and guinea-pigs, rats, and monkeys even, have been subjected to electric tests while living, in health and uninjured, while dying, and when dead ; but some of the most

interesting and suggestive phenomena of this science, those which have the nearest practical relation to electro-therapeutics, can be best studied on the living human subject, and without injuring the subject experimented on. This is the supreme advantage of the study of the physiological action of electricity over the study of the physiological action of the majority of drugs. The objection so often made against experiments made with medicines on inferior animals, that they do not teach the action of such medicines on the human body in disease, cannot, therefore, apply to electro-physiology, except to a limited degree.

Not a few of the physiological reactions of the human body to electricity can be studied while making therapeutical applications. The reaction of voluntary muscles, of the motor and sensory nerves, of some of the nerves of special sense, to electricity, and the general effects of electricity on nutrition, are taught us every time we electrize a patient by any of the familiar methods of application. Electro-physiology and electro-therapeutics thus go hand in hand.

*The Localization of Electricity in the Body an Advantage in Studying its Physiological Effect.*—The drugs with which we experiment on animals, in order to learn their physiological action, are usually absorbed and carried through the whole system; to confine their action to any part or member is impossible. If they select any organ on which to expend their force in preference to other parts, it is by virtue of their inherent affinity for such organ, and not from any power in the experimenter to confine them there. But electricity can, to a certain extent, be localized in a muscle or nerve, or in some special organ; thus its effects can be studied with greater precision and certainty than the effects of drugs internally administered. Thus the physiological action of electricity has a specially practical bearing on its therapeutical action.

*Animal Electricity is the Electricity that exists in Animal Bodies. Electric Fishes.*—The most remarkable display of animal electricity appears in certain varieties of fishes. At a very early period it was known that a certain flat fish had not only the power, when touched, to give forth shocks, but could impart to other bodies, for some distance through the water, a benumbing influence. This phenomenon was first proved by actual experiment to be of an electrical nature as early as 1773; and soon after, by means of a number of Leyden jars, connecting with a disk of leather or wood, either side of which was covered by tinfoil, an artificial torpedo was constructed. The subject of animal electricity is one of great scientific interest, and may in time become of direct practical value to electro-therapeutics. This peculiar power

is possessed only by a small number of fishes, the best known of which are the *torpedo* or *electric ray*, the *gymnotus* or *electric eel*, and the *electric shad*.

This development of electricity does not take place in all parts of the fish, but is confined to a peculiar expansion of the nervous system, called the electrical organ. The nerves constituting the electrical organs of the torpedo and gymnotus are of great size. Those of the former consist of three principal trunks, and arise from the cerebro-spinal system ; while the nerves composing the electrical organs of the latter are derived from the spinal cord alone. As stated above, the phenomena produced by these fishes are similar to those which are obtained from electricity that is artificially generated.

If electric fishes are touched with the hand, a shock is perceived, while if glass, resin, or any other non-conductor is intervened, no effect is produced.

Sparks may be drawn from them in the same way that they are drawn from other bodies that are artificially charged with electricity. The current obtained from them will magnetize steel needles, decompose water, and if the needle of a galvanometer be brought into the circuit it will immediately suffer deflection, so that the direction of the current may be readily determined.

The electric force of the fish is much weakened after it has exerted its power a number of times in quick succession, and it requires rest and nourishment to enable it to recover its normal vigor.

*History of the Discovery of Electricity in the Body of Man and other Animals.*—We have already seen (Electro-Physics, p. 48) that Galvani discovered in 1786 that muscular contraction follows the contact of the nerves and muscles of a frog with a heterogeneous metallic arc. From this observation, and from subsequent study of the subject, Galvani was inclined to believe and to declare that in the tissues of animals there exists a special independent electricity, which he called *animal electricity*. Although Galvani's conclusions were, as we now know, not entirely logical, yet he stumbled on an important discovery that was destined to be demonstrated and confirmed by other and later observers.

There *is* such a force as animal electricity, but the experiments of Galvani are explained by contact of dissimilar substances and by the chemical action of the fluids of the body on the metals, and not by the electricity of the body.

*Volta's Researches* have already been given in Electro-Physics (p. 50).

*Humboldt's Researches.*—In 1799 Humboldt published a work containing the result of many and curious experiments, the object of which was



to show that both Volta and Galvani were right and both wrong ; that there was such a thing as animal electricity ; that Galvani was in error in regarding it as the only form of electricity that appeared in his experiments ; and that Volta was in error in refusing to admit its existence.

*Aldini's and Nobili's Researches.*—In 1803 a nephew of Galvani, Aldini, published experiments that went to demonstrate the existence of animal electricity. The voltaic pile, however, was a stronger argument against the existence of animal electricity than any experiments could be in its favor, and for these reasons animal electricity was forgotten.

In 1827 M. Nobili, having constructed a very sensitive galvanometer, was enabled, as he supposed, to detect, without doubt, the existence of an electric current in the frog. He observed that when the needle was placed in the circuit it deviated some  $30^{\circ}$ .

*Researches of Matteucci and Du Bois-Reymond.*—A few years subsequently, Matteucci turned his attention to this subject ; but it was reserved for Du Bois-Reymond to investigate most clearly and most fully, if not most conclusively, the electric properties of the nerves and muscles.

By these two observers it is believed to have been shown, 1st. That currents in every respect like the frog-current of Nobili, are not peculiar to the frog, but are inherent in all animals, warm and cold-blooded—in toads, salamanders, fresh-water crabs, adders, lizards, glow-worms, and tortoises, as well as rabbits, guinea-pigs, mice, pigeons, and sparrows. (Du Bois-Reymond.)

2d. That currents are found in nerves as well as muscles, and that both are subject to the same laws. (Du Bois-Reymond.)

3d. That the current usually observed is a muscular current that is produced by the muscles, the nerves acting only as inactive conductors. (Du Bois-Reymond.)

4th. That this muscular current may be upward or downward, and that the current of the whole limb is the resultant of the partial currents of each muscle. (Du Bois-Reymond.)

5th. That these currents do not depend on the contact of heterogeneous tissues, as Volta had believed, for the nerves, muscles, and tendons in their electrical relations are homogeneous. (Du Bois-Reymond.)

6th. That electricity is found not only in the muscles and nerves, but also in the brain, spinal cord, and sympathetic—in motor, sensory, and mixed nerves—in a minute section as well as in a large mass of nervous

substances—in a small fibril as well as in a large muscle—in the skin, spleen, testicles, kidneys, liver, lungs, and tendons; but not in fasciæ, sheaths of nerves, and sinews.

7th. That animal electricity is capable of decomposing iodide of potassium, and of deflecting the needle of the galvanometer, (Matteucci.)

8th. In the muscles and nerves electricity is in the condition of a *closed circuit*.

9th. That contraction of muscle is accompanied by an electric *discharge* resembling that of a torpedo. (Matteucci.)

It was the perusal of the essay of Matteucci that inspired Du Bois-Reymond to undertake those magnificent researches that have given him a name and a fame in the realm of electrology.

He devised special apparatuses for his researches, and handled them with great skill and patience.

Even if many of the conclusions presented are erroneous, they are none the less interesting suggestions, and have prepared the way for those who are now earnestly seeking to discredit his experiments and disprove his statements.

The above conclusions of Du Bois-Reymond were derived from experiments on the nerves of frogs, but electricity is not confined to the lower forms of life, either dead or dying.

*Electricity in the Living Man.*—In the living man it is believed that cutaneous currents are found. The hand is negative to the elbow, and the palm of the hand is negative to the back. The foot is negative to the chest, and the sole of the foot is negative to the back. The elbow is slightly positive to the chest, and the hand is sometimes negative to the foot, and sometimes the reverse.

These cutaneous currents are quite strong and uniform. They are to be distinguished from the thermo-electric currents that are observed when two symmetrical parts are heated.

A finger at the temperature of  $32^{\circ}$  is positive to one at  $90^{\circ}$ , and a finger at  $60^{\circ}$  is feebly positive to one at  $80^{\circ}$ , and strongly positive to one at  $180^{\circ}$ . The cutaneous currents are also to be distinguished from currents that arise from dissimilar immersion, dissimilar sweating and shielding of the body.

Currents of electricity have been found in the urethra and bladder of the rabbit, the intestines, the spleen, the testicles, the tendons, and the oviduct of the frog, and the iris of birds.

All these currents resemble the ordinary muscular currents, in that the outer and inner surfaces have opposite electricities.

The currents of the nerves and muscles are very much stronger than those of other tissues.\*

Dr. C. B. Radcliffe takes a radically different view of animal electricity. His conclusions, briefly summarized, are as follows :

1. The sheaths of the fibres of nerve and muscle *during rest* are charged with electricity like Leyden jars. He believes it probable, though not entirely demonstrable, that the sheaths of the fibres conduct electricity so feebly that they are practically non-conductors and are di-electric.

This charge is brought about by the development of electricity, either positive or negative, through oxidation, or some form of chemical action, on the outside of the sheaths of the fibres, which electricity induces through the di-electric sheath, an opposite electricity from the inside of the sheaths, after the manner of the Leyden jar. Electricity which exists in the nerves and muscles during rest is in a statical condition, and not in dynamic or current state.

The nerve-current and muscle-current are purely incidental phenomena, resulting from applying the electrodes to points of unequal electric tension.

2. That the passage of a nerve or muscle from a state of rest to a state of action is accompanied by a *discharge* similar to that of a torpedo. The arguments in favor of this view are, that the anatomical and physiological apparatus of the torpedo closely resembles the muscular apparatus of all animals ; that the nerve-current nearly disappears from the nerve, and the muscle-current from the muscle, when nerve and muscle pass from rest into action ; and, finally, that the phenomena of induced or secondary contraction cannot otherwise be explained.

This discharge takes place between the sheaths of the fibres, which are very elastic, and are capable of being elongated during rest by the mutual attraction of the opposite electricities with which they are charged.

3. That when a nerve or muscle passes from action to rest it resumes its condition of charge. Elongation, therefore, is the result of charge, and contraction of discharge.

This point is illustrated by the following experiment :

A narrow band of rubber is wound on both surfaces very near the edge with gold-leaf, so that it can be charged or discharged with electricity like a Leyden jar. By a simple arrangement of a grooved wheel and an apparatus that multiplies and records the movements, it can be shown that when the band is charged by a few turns of a frictional machine, it

\* *Dynamics of Nerves and Muscles.* London, 1871.

elongates, and when the charge is discharged it contracts. It is believed that the muscle behaves in precisely this manner. If nerves are not affected in the same way, it is because their fibres are not sufficiently elastic.

4. That the blood keeps up the natural charge of electricity in nerve and muscle.

The acceptance of this view explains many interesting facts in pathology. It explains the fact that diseases that are accompanied by a deficiency in the nerve-currents, as neuralgia, spinal irritation, hysteria, tetanus, epilepsy, usually manifest themselves by morbid activity, by increased and unnatural movements of muscles and nerves.

Active inflammations, when there is increase of blood, are not usually accompanied by excessive muscular or nervous action.

*Apparatus for Studying Animal Electricity.*—In a practical work of this kind it is not necessary nor proper to enter into elaborate detail of all the experimental premises by which Matteucci, Du Bois-Reymond, Pflüger, and others have made their discoveries. A very brief description of the apparatus of Du Bois-Reymond may possibly be of interest.

He employed a very delicate galvanometer, the distinctive features of which were, *first*, the astatic needles were constructed and arranged with great care; and, *secondly*, the wire around them was very long, and of from 4,000 to 24,000 convolutions. A multiplier of this sort will indicate the presence of exceedingly feeble currents. The wires of the multiplier are connected with carefully cleaned and prepared flat new plates dipped in vessels of zinc, containing sulphate of zinc to prevent polarization. Two cushions, as they are called, made of layers of blotting-paper soaked in a solution of sulphate of zinc, are laid in the edge of each vessel, with their ends in the liquid. The whole is enclosed in a moist chamber. In order to protect any tissue, it is placed in connection with the two cushions in various positions; then, if there be any current, the deflection is seen in the needle of the multiplier.

When two symmetrical parts of the longitudinal or transverse section of a nerve are applied to the cushions, no deflection is seen; when two dissymmetrical parts of the longitudinal section are placed on the cushions, the needle deflects  $6^{\circ}$  or  $7^{\circ}$ . When the longitudinal section of the nerve on one side touches one cushion, and the transverse section touches the other side, the needle deflects  $15^{\circ}$  to  $30^{\circ}$ .

Instead of the galvanometer multiplier we may use the rheoscopic frog, which may give some results; but it has the disadvantage that it

loses its irritability, and that it contracts only when the current is closed or broken.

*Experiments of Trowbridge.*—We have given a full and varied presentation of the leading conclusions of Du Bois-Reymond and others, and have described, in a very general way, the best method of performing the experiments on which his conclusions are based.

We have done this in justice to a name that is greatly honored in science, in justice to the name that has made an era in physiology, and to prepare the student for an intelligent understanding of the experiments that seem to overthrow these views of Du Bois-Reymond that have been so widely accepted.

It has always appeared to us that in the experiments of all electro-physiologists, the later as well as the earlier school, there were chances for great error, and have been surprised that their conclusions have been accepted with so little reservation.

Bearing in mind that all chemical action, however slight, is probably accompanied by the generation of electricity, it is surely not irrational to suspect that the conclusions from careful experiments of Du Bois-Reymond and others might be in some, if not in all cases, modified by *chemical action* between the animal tissues and the cushions of the galvanometer, however skilfully these were protected.

Among the physicists at least, the theories of Du Bois-Reymond have been, on the whole, losing ground during the past ten years, and probably on account of the considerations that are above presented.

Prof. John Trowbridge, of Harvard College, has recently made a series of researches that seem to cast grave doubts on the interesting and hitherto accepted conclusions of Du Bois-Reymond in regard to animal electricity.

This physicist, starting out on the face of the accepted fact *that two liquids of dissimilar chemical character, separated by a porous partition, give rise to a current of electricity*, has made experiments with an apparatus similar to that employed by Du Bois-Reymond in his researches on animal electricity. Instead, however, of placing a piece of muscle or nerve on the cushions, he used a series of *artificial muscles*. These artificial muscles were made of glass-tubes covered by porous partitions, and filled with the different liquids, such as—

- Undistilled water,
- Weak solution of salt in distilled water,
- Solution of different salts of iron,
- Blood,
- Acidulated water.

Placing the artificial muscle thus prepared in the position where the natural muscle is placed in Du Bois-Reymond's experiments, he found that each liquid *caused a deflection of the needle of the galvanometer.*

There is no question, in the opinion of Prof. Trowbridge, that the currents that caused these deflections of the needle arose from the *actions of the fluids in the tubes on the saline solution of the cushion and the protecting guard.* This view is confirmed by the fact that when the artificial muscles were, filled with *distilled water*, there was no deflection of the needle observed; but when undistilled water or the other fluids mentioned were used, the needle of the galvanometer deflected so far as in some cases to throw the spot of light off the scale.\* Prof. Trowbridge exercised the same precautions as are found necessary by electro-physiologists in obtaining the so-called muscular currents. He argues that the behavior of the artificial muscle must be similar to that of a natural muscle placed on the cushions; and he states further, that when we use the natural muscle, containing fresh and chemically active blood, separated by its sheath from the clay guards of the cushions, *an electrical action must take place between the fluids of the muscle and the saline solutions in the connecting apparatus, which action cannot well be distinguished from the so-called muscular current.†*

In order to avoid every possible source of error in these experiments, Prof. Trowbridge not only tried distilled water in the artificial muscles, instead of undistilled water and the different solutions, but also tried the mere contact of the bladder membrane-partition without any fluid, and in neither case was any current produced. He employed a vessel shaped like the letter U, opened at the bend, and covered at the ends by a membrane. Into the two limbs of the tube he injected fluids of different kinds. When the vessel was filled with a fluid that was homogeneous, and the ends of the tube brought in contact with the cushions, the needle of the galvanometer was deflected. When the points of contact were reversed, the direction of the needle was reversed. That mere *contact* of the tube with the cushions did not cause the deflection of the needle, was shown by the fact that when no fluids were in the tube there was no deflection. That the direction of the current was *through* the U-shaped tube, and not from its extremities to the galvanometer and back, was proved by the fact that when the section of one of the limbs of the U-shaped tube was constricted, the

\* Thomson's reflecting galvanometer and new quadrant-electrometer were used in these experiments.

† On the Electro-motive Action of Liquids separated by Membranes. *American Journal of Science and Arts*, vol. iii., May, 1872.

deflection of the needle was reduced, and when the constriction was complete there was no deflection.

The conclusion to which Prof. Trowbridge arrives from these experiments, which have been repeated at various times, is, "*that when the cushions of the galvanometer are connected by a membranous sac containing fluids, or animal tissue saturated with fluid, an endosmotic action takes place, accompanied by galvanic action; and that this galvanic action is determined by the difference of endosmotic action at various points of the enclosing membrane.*" \*

When, therefore, a muscle is placed on the cushions of the galvanometer, its transverse section on one pad and its longitudinal section on the other, endosmose takes place, which is different at different points, and the galvanic current that appears is probably caused by this difference of endosmotic action and not by the so-called muscular current. Then granting that a muscular current exists, it must suffer important modifications in strength and direction through this endosmotic action. *If the muscular current does not exist, this endosmotic action, with the accompanying galvanic action, will account for the deflection of the needle of the galvanometer that had been supposed to be due to the muscular current.*

In a letter received by Dr. Beard from Prof. Trowbridge, under date March 28, 1873, nearly one year later than the date of the publication of the researches of which the above is an abstract, he says that "later experiments have convinced me that there are no such currents as muscular currents, properly so called. I think that the phenomena noticed by Du Bois-Reymond arise from differences in the chemical nature of different portions of the muscle. Du Bois-Reymond contends that such chemical difference does not exist, and that the tissue is homogeneous from a chemical point of view. It must be remembered, however, that a delicate galvanometer can detect differences in chemical composition which cannot be detected except by the most refined analysis. I should therefore make my assertions stronger than I have done, in the accompanying papers, in view of subsequent experiment."

Prof. Trowbridge has also made experiments that seem to cast grave doubts on the conclusions of Du Bois-Reymond in regard to *electrical currents* in the *arms*. Du Bois-Reymond in his experiment connects the terminals of a galvanometer in separate vessels by a siphon-tube containing the same liquid as the vessel. The ends of the tube are covered with a porous preparation.

\* Proceedings of the American Academy of Arts and Sciences, January 9, 1872.

Placing a forefinger in each vessel and violently contracting the arm, he observed that the needle of the galvanometer was deflected ; on contracting the other arm, the needle deflected in the opposite direction. Du Bois-Reymond explained this phenomena by the theory that electrical currents circulate in the arm distinct from and co-existing with the muscular and nerve-currents. It is not difficult to conceive that in an experiment of this kind there would be chances for error sufficient to make us very cautious in accepting any immediate conclusions in regard to it. In order to test the validity of this conclusion, Prof. Trowbridge prepared a vessel with two limbs, which he substituted for the human finger. Du Bois-Reymond's experiment-vessel was filled with a solution of salt, and the end of the limbs was covered with prepared membrane. The resistance of the circuit through both limbs and the vessel was about that of the human body from the forefinger of one hand to the forefinger of the other—that is, about seven or eight times the resistance of the Atlantic cable. The ends of the limbs or tubes were immersed in the fluid of the vessel connected with the galvanometer. As soon as they touched the liquid, the needle of the galvanometer was deflected, and on reversing the limbs the needle was deflected in the opposite direction.

When the flexible portion of one of the limbs was pinched so as to diminish the diameter, the deflection was also diminished. When a trifling change was made in *the chemical character of the fluids in the two limbs, and one of the limbs was slightly contracted, the direction of the needle was reversed.*

Prof. Trowbridge is disposed to believe that the deflection of the needle caused by the contraction of the muscles of the arm, "is produced either by the temperature or by the change in the flow of the blood." It has been established, that the electro-motive force between venous and arterial blood is about one-thirtieth that of a Daniell's cell ; and as muscular contractions change the chemical character of the blood, and as by very slight chemical difference between two fluids separated by a membrane, like the skin, is sufficient to create a galvanic current, it is not improbable that the conclusion of Du Bois-Reymond in regard to the existence of a separate electrical current in the arm is erroneous.



## CHAPTER II.

### ELECTROTONOS, ANELECTROTONOS, AND CATELECTROTONOS.

*Electrotonos is the peculiar modification of irritability that nerves and muscles undergo when acted upon by a galvanic current.*

While the nerve is in the electrotonic state, that part of it not included between the poles will deflect the needle of a delicate galvanometer; and that the deflection then caused is not due to the natural nerve-current, is proved by the fact that it appears when only the surface of the nerve is connected with the galvanometer. It is therefore the electric condition of the nerve caused by the passage of the current through it that deflects the needle. The electrotonic condition not only remains so long as the galvanic current continues to pass, but, if the current be sufficiently powerful, it remains for a limited time after the current ceases to pass.

The electrotonos is more noticed the larger the extent of nerve acted upon, provided the current be sufficiently increased to overcome the increased resistance.

In nerves that are dead, or have lost their irritability, electrotonos cannot be excited at all, or only feebly, and the same is true when the nerve is cut across or tightly bound with a ligature.

The change in the nerve-current depends on the direction of the galvanic current. When the galvanic current flows in the same direction with the nerve-current, the strength of the nerve-current is increased; when the galvanic current flows in a contrary direction, the strength of the nerve-current is diminished.

Electrotonos is greater when the galvanic current flows lengthwise than when it flows across the nerve. It increases, within certain limits, with the increase in the intensity of the current.

*Molecular Theory of Anelectrotonos.*—Du Bois-Reymond has suggested a theory to account for the phenomena of electrotonos, which has been generally accepted. It is analogous to the theory of magnetism suggested by Coulomb. He supposes that muscles and nerves consist of electric molecules, which have one positive equatorial zone

and two negative polar zones, whose axes are parallel to each other; that is, two molecules make one molecule. This is called the *peri-polar* arrangement. In a magnet, each individual molecule manifests the same phenomena as the entire magnet: each molecule is indeed a magnet in miniature. In like manner, each molecule of the nerve or muscle manifests the same phenomena as the entire nerve or muscle. These peri-polar molecules are enclosed by a moist covering.

Du Bois-Reymond further supposes that each peri-polar molecule may be divided into a group of *di-polar* molecules—where the positive

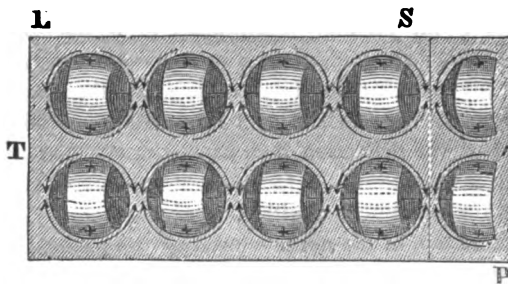

FIG. 32.

Peri-polar Arrangement of Electro-motor Molecules.

L S—Longitudinal Section.

T S—Transverse Section.

P—Parelectronic Layer.

hemispheres are turned toward each other—without changing their electrical properties. This is called the *di-polar* arrangement. If a number of such molecules are brought under the influence of a galvanic current, their positive zones will turn toward the negative pole, and the negative toward the positive; one of the molecules (3) turning  $180^\circ$  on its axis. The arrangement will be as above. From its resemblance to the voltaic pile it is called the pile-like arrangement.

This pile-like arrangement of the molecules not only takes place between the electrodes, but also beyond them into the extra-polar region.

Du Bois-Reymond has illustrated these phenomena on molecules made of zinc and copper.

From these experiments Du Bois-Reymond concluded, first, that the nerve is always in the condition of a closed circuit, since electric currents are produced by the connection of layers surrounding the molecules with their molecules; and secondly, that the current obtained from an animal, as indicated by the galvanometer, is only a small portion of the entire current.

The galvanic current that produces the electrotonic condition is called the *polarizing current*. The portion between the poles is called *intra-polar*; beyond and outside of the poles, *extra-polar*. Electrotonos is *ascending* when it proceeds from the muscle to the nerve; *descending* when it proceeds from the nerve to the muscle.

*Anelectrotonos and Catelectrotonos.*—*Anelectrotonos* is a condition of diminished irritability which takes place at the positive electrode. *Catelectrotonos* is a condition of increased irritability which takes place at the

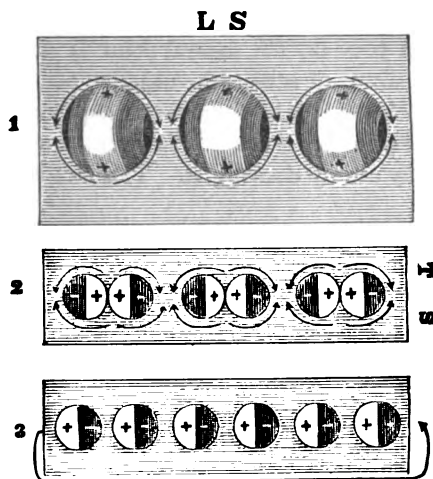

FIG. 33.

L S—Longitudinal Section.

T S—Transverse Section.

1. Peri-polar arrangement of electro-motor molecules.
2. Di-polar arrangement of electro-motor molecules.
3. Pile-like arrangement of electro-motor molecules, caused by the action of the galvanic current.

*negative electrode.* At some point between the electrodes the irritability of the nerve is unchanged. The conditions of anelectrotonos and catelectrotonos are found not only between the poles, but also in the other portions of the nerve, in the *extra-polar* portion.

The portion between the poles and near the negative pole, together with the portion beyond the negative pole, is in a state of catelectrotonos, with increased irritability. The portion between the poles and near the positive pole, together with the portion beyond the positive pole, is in a state of anelectrotonos, with diminished irritability.

The extra-polar catelectrotonos depends on the length of the nerve between the poles, and the strength of the current, up to a certain limit. The strength of the extra-polar anelectrotonos is proportioned to its

distance from the poles, being greatest near the intra-polar portion. The extra-polar catelectrotonos, both ascending and descending, is in a state of increased irritability. The extra-polar anelectrotonos, both ascending and descending, is in a state of diminished irritability.

*Neutral Point.*—Between the poles there is a point where the irritability is not changed; there anelectrotonos meets catelectrotonos. This is called the neutral point. The relative position of this depends on the strength of the polarizing current. Where the strength of the current is medium, the neutral point is about midway between the poles. Where the current is weak, the neutral point is nearer the positive pole. Where it is strong, it is near the negative pole.

*Negative Variation.*—When a current frequently interrupted is applied to an irritable nerve, it causes the nerve-current to *diminish in strength*, and finally utterly destroys it. This fact is demonstrated by the galvanometer.

The same phenomena is caused to a less degree by chemical or mechanical stimulation of nerve. Negative variation has been explained by the theory that the peri-polar molecules in the nerve change their arrangement, so that their electro-motor power is diminished. The negative variation of the current has been studied by Bernstein. He regards all the electric phenomena of the nerve as undulatory movements, and has mathematically estimated the length of the waves in nerve and muscle. Cyon, in confirmation, has shown that the degree of the variation is directly proportioned to the number of interruptions in the exciting current.

*Effects of Electrotonos in Diminished Conductivity.*—The power of a nerve to conduct irritability is more or less modified by the condition of electrotonos. The portion of the nerve near the positive pole, which is in a condition of anelectrotonos, has its conductivity diminished; the portion of the nerve near the negative pole, which is in a condition of catelectrotonos, has its conductivity increased. If the current be sufficiently strong, the power of the nerve to conduct impressions may be nearly or entirely destroyed.

*Effects of Electrotonos after the breaking of the Galvanic (polarizing) Current.*—One of the effects of the electrotonos is the *irritation* which is caused by the passing away of the anelectrotonos. This irritation, which appears at the positive pole, is shown either by a contraction or by a tetanic condition.

*Positive Modification and Negative Modification.*—The nerve which is in a condition of catelectrotonos at the negative pole is greatly modified by the breaking of the polarizing current. Its irritability is

thereby diminished. This diminution of irritability is called the "*negative modification*." At the positive pole in the catelectrotonic region, an increase of irritability, or *positive modification*, appears on breaking the current. This increase and diminution of irritability continue for some time after the polarizing current is broken.

*Effect of a Change in the Direction of the Current.*—Another effect of electrotonos is the change of irritability which is caused by a change in the direction of the current. If a nerve is subjected for some time to the influence of a galvanic current in a certain direction, it loses some of its irritability, which it regains when the current is reversed.

*Restoration of Irritability.*—A very important effect of electrotonos is a restoration of irritability in a nerve. It has been proved, both by experience and by experiments, that nerves, which from any cause have lost their irritability to the faradic current, sometimes regain it after an application of the galvanic. It has been shown by the experience of several writers on electro-therapeutics, and of ourselves, that, in cases of paralysis, when the faradic current at first fails to produce contractions, the application of the galvanic may not only readily produce contractions, but may also produce *such a change in the irritability of the paralyzed parts as to cause them to regain their lost irritability to the faradic current.* (See Electro-Therapeutics.)

*Electrotonos of Muscle.*—A muscle, like a nerve, may be put in the condition of electrotonos; the changes of irritability that accompany this condition are confined to the portion of muscle through which the current flows. The subsequent effects, after the polarizing current is broken, are also limited to the portion through which the current passes.

It is logically probable, also, that not only the motor-nerves, but also all parts of the nervous system—central and peripheral—are capable of exhibiting the phenomena of modified irritability under the galvanic current.

*Theory of Anelectrotonos and Catelectrotonos.*—That the galvanic current in its passage through the nerve diminishes the irritability of that nerve in the region of the positive pole, and increases its irritability in the region of the negative pole, may be explained by the purely physical effects of the currents in the tissue.

We have seen that in electrolysis acids go to the positive and alkalis to the negative pole; now it is a fact of physiology that acids diminish the irritability of nerves, while alkalis increase it. Anelectrotonos and catelectrotonos may therefore be caused by acids at the positive and alkalis at the negative pole.

This explanation is rendered probable by two facts: *first*, that

anelectrotonos and catelectrotonos are **not** produced by the secondary faradic current, which has no marked chemical action; and *secondly*, that very feeble and instantaneous passages of the galvanic current produce electrolytic effects.

*Pflüger's Contraction-Law.*—The law of contraction, as derived by Pflüger from experiments on the frog, is thus formulated: *The nerve is excited by the appearance of catelectrotonos, and the disappearance of anelectrotonos, but not by the appearance of anelectrotonos or the disappearance of catelectrotonos.* This law is considered of great scientific as well as practical value.

*Electrotonos in the Living Man.*—The subject of electrotonos in the living man has been studied by Eulenburg, Samt, Von Bezold, Brenner, Erb, Brückner, Runge, and Filehne, but most successfully by Cyon.

Cyon,\* by a series of elaborate and careful experiments, has shown that the contraction-law of Pflüger, as established on the frog preparation, applies also to the living human subject.

He has shown that, after closing the circuit, the irritability is increased near the negative pole; that this condition of catelectrotonos increases as the current runs up to a certain point; that on breaking the current the *negative modification*, or condition of diminished irritability, appears for a moment, and then disappears.

Near the positive pole, on the other hand, the irritability is diminished at and after closing the current. On breaking the current there is an increase of irritability, or *positive modification*, which appears to be greater when the current has been allowed to run a long time.

The experiments from which Cyon derived these conclusions were made on the ulnar nerve, and with great care to avoid error. It will be seen that the results correspond with the results of Pflüger's experiments on the frog, and confirm them. Cyon found, however, that these results were not uniform in all persons, but were modified more or less by temperament and disease.

*Practical Bearings of the Laws of Electrotonos.*—While the laws of electrotonos do not account for all the therapeutical action of the galvanic current, they are, nevertheless, of great value, and help to explain the practical differences observed in the action of the two poles. In a carefully prepared article, however, by De Watteville,† the conclusion is reached "that a therapeutical system, built on the opposite anelectrotonic and katelectrotonic effects, rests upon an imaginary basis. . . . Both are stimulants, if 'stimulation' there be, the kathode more than the anode."

\* *Principes d'Electrothérapie.* Paris, 1873, p. 130 *et seq.*

† *Conditions of the Unipolar Stimulation, etc.* "Brain." Part IX.

## CHAPTER III.

### ACTION OF ELECTRICITY ON THE SKIN.

IN regard to the study of the action of electricity on the body in health, it is necessary to make the preliminary remark that many of the experiments that have been made and published, and widely quoted in this department, have but little scientific value, and cannot be regarded as in any sense authoritative. The reason for the uncertainty pertaining to the reported experiments are manifold :

1. *The distinction between the currents has not been observed.* Not only have the faradic and the galvanic currents been constantly confounded, but the subdivisions of the faradic current—the electro-magnetic and magneto-electric—have been vaguely commingled. Many observers speak of galvanization when they mean faradization, and *vice versa*, and not a few apply both terms to the use of the same current.

2. *Allowance has not been made for the differential action of strong, medium, and feeble currents, or of long and short applications.* The difference in the physiological effect of a large and small dose of opium, strychnine, belladonna, or ergot, or any other powerful remedy whatsoever, is enormous. When a small dose has no perceptible effect, a large dose may throw into profound sleep, or into violent convulsions, that lead to death. In speaking of the physiological action of drugs of any kind, the dose is always mentioned, and any experiment with drugs, on man or animals, when the dose is not known or mentioned, has little value in science. Similarly also in electro-therapeutics, we find in every-day experience that the difference in the effects of a mild and short, and a severe and long, application, is only the difference between making a patient infinitely better or infinitely worse.

When, therefore, we read that galvanization of the sympathetic or pneumogastric produces such and such effects, we really get no precise knowledge whatsoever.

3. *The differential susceptibility of man and animals has not been duly considered.* Experiments with electricity performed on the lower animals, as frogs, dogs, cats, horses, rabbits, cows, guinea-pigs, etc., do not

always afford a safe basis for generalization in regard to the effects of electricity on man, and especially on man in a state of civilization. In their susceptibility to the electrical stimulus, and in the length of time that they retain their irritability after death, there is a great difference in animals; between animals and civilized man this difference must be very great.

In proportion as the organization of man is more complex than that of the lower animals, in that proportion will the physiological reactions of the human body to the electric current, or indeed to any other influence, be more complex and uncertain, and more liable to deviations and modifications than the physiological reactions of the inferior forms of life to which we are supposed to be related. Conclusions in electro-physiology, derived solely from experiments on animals, have the great merit of simplicity; but when applied to the far higher and more complex organization of man, and especially of civilized man, with his excessively sensitive system of nerves, they are apt to lead into serious error.

4. *Individual idiosyncrasies have not been properly considered.* The action of medicines varies with the temperament to such a degree as to make necessary great caution in rushing to generalizations from experiments on one or two persons. Applications of electricity, faradic or galvanic, to the cervical sympathetic, similar in length and strength, may cause in one individual symptoms of cerebral congestion, in another symptoms of cerebral anæmia, and in another its effects may be purely negative. In one individual the effects of such application may be felt at once, in another an hour or two after the application, in another not until the following day.

There is a great difference in the average susceptibility of different nationalities and of the higher and lower orders of society, with occasional exceptions both ways; the tough, coarse-fibred laboring classes are much less susceptible to electricity, just as they are much less susceptible to drugs, than the delicate, finely organized, brain-working classes.

5. *The action of electricity on the body in health may be learned, in part at least, by studying its action in disease.*

"Pathology," Allbutt well says, "is but the shady side of physiology." To draw the line precisely where health ends and disease begins, is oftentimes beyond the power of mortal man. Of the deep darkness of the midnight-hour any child is conscious, and even the birds discern the approach of evening; but what physicist so keen as to tell the precise moment when the late afternoon begins to fade into the early twilight?



It is because physiology and pathology thus run into each other, that observations on pathological states may be of great service to physiology. Experiments made with electricity on patients more or less diseased have helped, as we shall see, to solve some of the problems of electro-physiology. Certain pathological states render the nerves unusually impressible to electricity in degree, though in the same way as in health, and thus are of great value to the electro-physiological experimenter.

The above considerations explain in part the opposite and inconsistent as well as fragmentary character of electro-physiological researches, and they should be borne constantly in mind by those who study this and the following chapters, devoted to the action of electricity on the human body in health.

*Action of Franklinic Electricity.*—When the sparks of frictional electricity are applied to the skin they produce a sensation of pricking, and if the sparks are large the skin becomes red and a papular eruption appears. Applied to the scalp, it causes the hair to stand on end.

*Action of the Faradic Current.*—If any *dry* artificial electrode is pressed against the dry skin while a faradic current is passing, the electricity will penetrate but slightly to the deeper tissues, unless the current is very intense, because of the great resistance offered by the skin.

One effect of the faradic current on the skin in this way is to cause a *change in the circulation*. The change may be either anæmia or hyperæmia. At first there is anæmia. The calibre of the blood-vessels is narrowed, through the action of the current on the vaso-motor nerves. This contraction with anæmia is spasmodic in its character; it lasts but for a time, and in the course of two or three minutes it gives way to hyperæmia. The skin becomes red, and remains so for a short or long time, from several minutes to several hours, according to the strength of the current, the length of the application, and the temperament of the individual.

Another effect of faradizing the skin in this way is pain. This pain is caused by the irritation of the extremities of the sensory nerves.

When the dry hand is substituted for the dry artificial electrode, the surface can be faradized without producing pain. During the latter operation the electricity, acting upon the dry surface of the skin, produces a peculiar cracking or humming sound that may be heard several feet.

An application of a faradic current of ordinary strength is followed by the most marked effects on the skin when it is dry, from the fact that the electricity is mostly confined to the surface of the tissue. A

very fine, or, in other words, a rapidly interrupted, faradic current, has a more marked effect on the sensory nerves than a coarse, or slowly interrupted, current, and in the treatment of the more common forms of anæsthesia and neuralgia this fact must be considered. *The negative pole has a much stronger effect both on the sensory and motor nerves than the positive. Any one can readily distinguish the poles, when held in the hand, by the stronger sensation and more violent muscular contraction which is felt at the negative.*

Some parts of the skin are more sensitive to the current than others, from the fact that they are more richly supplied with nerves. The face is especially sensitive at the points where the various branches of the trigeminus issue, and at the line of demarcation of the skin and mucous membrane of the nose and mouth. The relative sensitiveness of different parts of the surface of the body to the faradic current will be discussed in detail in a chapter devoted to that subject in the section on Electro-Therapeutics. A faradic current of moderate strength, when applied to bones that lie very near the surface, produces considerable pain of a peculiar character. This pain is caused on account of the irritation of the sentient nerves of the periosteum. The forehead and the region of the scapula and tibia are especially sensitive to electrization.

It is not supposed that the bone is specifically affected by the electric current. Both the periosteum and the bone, however, may have an increased amount of blood attracted to them by the electric current. Acting in this manner, electrization has been known to reunite an old fracture. (See Electro-Surgery.)

The great and peculiar sensitiveness of the skin to electricity is explained in part by the fact that the epidermis as a whole is so poor a conductor, and the electricity enters it *by points* through the sudoriferous and sebaceous glands, and the smaller the diameter of the point at which the electricity enters a body the greater the density, the strength of the current being constant. When now an electrode is applied to the body, the entire current, instead of diffusing itself over the whole surface, enters at the glands, where there is best conduction, and consequently excites pain. For the same reason, to a greater degree, electricity applied by means of a metallic brush is far more painful than when applied with a broad metal or sponge.

For the same reason a wet sponge electrode, when lightly touched to the surface of the body, causes more pain than when firmly pressed on the skin.

One effect of faradizing the skin is the phenomenon of "goose-flesh,"

popularly so called. This is noticed not only where the electrodes are applied, and between them, but at a distance. It is more observed in the nervous and feeble than in the hardy and strong. It may be excited by weak currents of momentary duration. In some persons it cannot be excited at all.

*Action of the Galvanic Current.*—The effects of the galvanic current on the skin differ somewhat from those of the faradic. At both poles there is a *burning* sensation, which increases in intensity with the strength of the current and the length of the application. The sensation, when the current is closed, is like that of a mustard-plaster, or, with a very strong current, that of a hot iron pressed on the skin. The “goose-skin” sometimes appears as under the faradic current, but it lasts longer. It appears only around the poles, and not beneath them, at the points of contact. At the *positive pole*, in some cases, there appears under the electrode, at first, a shallow depression, and the skin is pale, but soon hyperæmia appears, and many little elevations here and there. When a strong current is used an ischæmic appearance is presented beneath the electrode, and a red areola extends for some distance around.

At the *negative pole* substantially the same phenomena appear, but the hyperæmia arises more rapidly, and is more intense and extended.

The general sensation caused by the galvanic current is then, *in character*, substantially the same at both poles. In *degree* of action there is a certain difference, since the change at the negative develops more rapidly and powerfully.

The above phenomena we have repeatedly demonstrated on a variety of temperaments. We have observed that the rapidity and strength of the action are considerably modified by the individual. Soft, thin, and delicate skins appreciate the burning feeling and the various stages of hyperæmia more quickly than skins which are coarse, thick, and hard.

Ziemssen, who has carefully studied this subject, states that *unpolarizable* electrodes are necessary in order to obtain the complete results with certainty. The advantage of unpolarizable electrodes is, that they are not so painful, and so a current of from thirty to sixty elements can be borne for a long time, say from ten to thirty minutes. With ordinary electrodes such a current would for most persons be unendurable after the second minute.

*Chemical Effects of the Galvanic Current on the Skin.*—The chemical effects of the galvanic current on the skin differ not only in degree but in kind. Under the *negative pole*—when metallic electrodes of moderate diameter are applied on the skin, slightly moistened—there appear small, pale vesicles, that are transparent and are not raised much above the

skin. This phenomena is produced by a current that causes a strong burning sensation. These vesicles contain fluid and layers of epidermis. The fluid is *alkaline*. When the strength of the current is increased the fluid becomes of a brownish color, and blisters are formed and a red areola appears. The serum that comes out on the skin is alkaline. These blisters, and all the other phenomena, as has been often demonstrated, appear more rapidly on delicate than on thick skins, and when fully formed they are a long time in healing, and for days and weeks a yellowish and brownish discoloration may be observed at the points where the skin was acted on.

If the application be still more protracted little ulcers are formed, that are also slow to perfectly heal, but are not painful, and cause no annoyance.

At the *positive* pole, when a strong current is used for some time, a blister appears, accompanying the other symptoms of "goose-flesh," ischæmia. The blister is colored in its centre a yellowish brown. The serous fluid that comes from the blisters is *acid*. The metallic electrode becomes black through *oxidation*. In order to demonstrate this action of the positive pole, it is better to have the connection at the negative pole established by means of a broad, soft, and well-moistened sponge.

Ziemssen states that by this experiment, made with thermometers, no elevation of temperature takes place either at the positive or negative pole.

In all these chemical actions of the galvanic current on the body, it is probable that more or less ozone is produced, and it is not impossible that the ozone thus produced may in some way modify the effects. (See section on *Ozone* and *Ulcers*, in *Electro-Therapeutics*.)

*Electro-anæsthesia*.—It has for some time been a matter of dispute whether a slight anæsthesia can be produced by the electric current. It is well known that for a number of years some dentists have been accustomed to connect the forceps for extracting teeth with one pole of an electro-magnetic apparatus while the patient rested his foot on the other pole, so that as soon as the forceps seized hold of the tooth a current is established. Although this method of producing anæsthesia is not now received with favor, there is no question that the electric currents do have a slight benumbing effect. The results of various experiments that we have from time to time performed in this department seem to be conclusive. We have had teeth extracted while a strong faradic current was passing through the jaw, and feel assured from this personal

experience that the electricity caused the pain to be less sensitively felt. That the pain caused by the prick of a pin, for example, is less sensitively felt when a strong faradic current is passing through the part where the puncture is made, we have practically demonstrated on the hand and other parts of the body.

Althaus\* arrived at the conclusion that the electric current could produce an anæsthetic or slightly paralyzing effect, from experiments on the nerve-trunks, as the ulnar and sciatic. His method of operating was to place the positive pole over some point where the nerve was superficial, and the negative over some one of the terminal branches, keeping up the action of the current for fifteen minutes, with the result of producing a feeling of numbness, and less sensitiveness to the current. Knorr, of Munich, has availed himself of the anæsthetic effects of electrization for opening felons and buboes.

We have also experimented on inflamed and irritated mucous membranes. In rhinitis, pharyngitis, and laryngitis, we have for three years been accustomed continually to make use of the benumbing effects of electrization.

It has a very slight anæsthetic effect on irritated and inflamed mucous membrane, and those on whom it has been employed desire to have the applications repeated. Our custom has been, in some cases, to use local faradization after the application of caustics and other irritants, in order to relieve the very annoying pain that they so often cause, or in any irritable condition of the parts.

A French physician, M. Victor Revillout, has obtained similar results from applications of the faradic current to the uterus after cauterization. †

*Electrical Excitability of the Skin.*—Tschiriew ‡ and De Watteville have pointed out a method by which the absolute and relative excitability of the cutaneous nerves can be readily tested. The principles of their method are: 1st. Elimination of all the sources of variation in the strength of the currents due to the variable thickness of the epidermis, and the different positions of the electrodes, etc., by intercalating in the circuit such resistances as to make such variations insignificant. 2d. Elimination of the variable abundance of nervous elements in the skin, by exciting it at a constant number of points, dispersed over a constant surface.

\* *Medical Electricity.* 1860. pp. 166, 167.

† *Archives Générales de Médecine.* September, 1868. p. 356.

‡ *Brain.* Part VI.

## CHAPTER IV.

### ACTION OF ELECTRICITY ON THE BRAIN AND SPINAL CORD.

*Direct Application.*—It has been shown by Fritsch and Hitzig that in the cerebral convolutions there are centres for the production of voluntary muscular movements in various parts of the body. These physiologists took off the upper part of the skull of a dog, and by means of weak *galvanic* currents excited the exposed brain, locating the current, as far as possible, in small portions. They found that when certain definite portions of the anterior convolutions were excited, *movements were caused in certain groups of muscles on the opposite side of the body.* Continuing their researches, they showed that there are definite nerve-centres for the nerves that preside over the muscles of the neck, the foot, and the face, for the extensor and adductor muscles of the forearm, and for the flexor and rotator muscles of the arm.

Prof. Ferrier, of King's College, London, has made similar researches with the *faradic* current, and with it has investigated the brains of fish, frogs, dogs, cats, rabbits, guinea-pigs, and monkeys. He has studied not only the cerebrum, but the cerebellum, the corpora quadrigemina, and other portions of the brain. Electrization of the optic thalami produced no result. Electrization of the corpora striata caused the limbs to be flexed. Electrization of the anterior tubercles of the corpora quadrigemina caused dilatation of the pupils and opisthotonus; while electrization of the posterior tubercles caused the animal to make all sorts of noises. Electrization of the cerebellum caused movements of the eyeballs. Dr. Beard\* has carefully studied this subject on the brains of dogs, rabbits, cats, and pigeons. He used both currents, mild, medium and strong, and studied also the question of diffusion of currents. His provisional conclusions were, that the surface of the brain was electrically excitable; that the theory advanced by Dupuy and other French observers, that the excitation was due to the diffusion of the currents to the central ganglia, was not tenable. Dr. Bartholow† had made

\* Archives of Electrology and Neurology. May, 1874.

† Ibid.

similar experiments on the brain of a living woman, exposed by cancerous disease.

*Effects of External Galvanization of the Brain.*—The leading effect of medium and strong galvanization of the brain by external application in the living human subject is different. When one electrode is placed on the forehead and the other on the occiput, or one on the summit of the head and the other on the stomach, galvanization is followed by little if any tendency to vertigo. When a current of even feeble tension is passed from temple to temple, or from one mastoid bone to its fellow, very decided dizziness is at once perceived, which continues during the operation of the current, and becomes most decidedly manifested at the moment the circuit is broken.

During the passage of the current there is a very marked and quite irresistible tendency to lean toward the positive pole, while objects in view seem to move in the same direction. When the circuit is opened there is a reversal in the direction of the seeming movements, and the experimenter instantly bends in the opposite direction toward the negative pole.

For these phenomena an ingenious and plausible explanation is given by Hitzig. When the current passes from the forehead to the occiput, the right and left lobes of the brain and all that pertains to them are equally or symmetrically influenced, and little if any dizziness is perceived. Place, however, the anode upon one temple and the cathode upon the other, and mark the readiness with which dizziness is produced.

In this operation the brain is no longer symmetrically affected. One hemisphere is in a condition of anelectrotonos, or diminished irritability, while the other is in a condition of catelectrotonos, or increased irritability, or, as it is expressed, there is a falsification of the muscular sense, a disturbance of the equilibrium, and the apparently involuntary inclination toward the anode is in reality a voluntary effort to restore the imaginary loss of balance.

Hitzig indicates several degrees of galvanic giddiness.

1. *A mere sense of fulness in the head.* This feeling is caused by a mild current when broken, but not usually when the current is running, nor so markedly when the current is closed. Certain temperaments, however, experience this feeling not only when the current is broken, but also when it is running.

2. *Apparent movements.* These are produced by stronger currents. Objects when the current is running appear to go from the positive to the negative pole; when the current is broken the apparent movement is reversed.

3. *Staggering.* This is produced by stronger currents. In impressible temperaments very mild currents may produce it.

*Movements of the Eyes.*—*Movements of the eyeballs* have also been observed by Hitzig during the second and third stages of dizziness. When a strong current goes transversely through the head, and its direction is changed, movements of the eye, resembling nystagmus, appear. There is a jerk, and then a further movement. If the positive pole be in the right mastoid, and the negative in the left, both eyes are jerked toward the left, and kept there, provided the current be sufficiently strong.

There are anatomical reasons for supposing that the brain can be more easily affected in the mastoid and occipital regions than in the anterior portion. A large vein connects the transverse sinus with the posterior auricular veins, and with the posterior meningeal artery into the skull through the mastoid foramen. In the occipital region a vein connects the transverse sinus with the vena cervicalis profunda through the posterior condyloid foramen.\*

#### SPINAL CORD.

Rigid cramps of all the muscles of the trunk and extremities follow electrization of the spinal cord when an electrode is placed at either extremity of the cord. Cramps of the same character are also produced when one electrode is applied to the anterior and the other to the posterior column, either at their upper or lower extremities.

If the spinal cord be divided at about its centre and the lower half electrized, only the muscles of the lower or hinder limbs will contract. If the upper half be electrized, only the muscles of the fore limbs will enter into contraction. The results will be the same, whether the cut extremities are separated or brought in close contact, in which latter condition no impediment is offered to the passage of the current. The above researches of Weber have been confirmed by Dr. Beard's experiments on dogs and rabbits. The effects are produced by both currents.

*Inhibitory Effects.*—At the moment of closing and breaking a galvanic current its action upon the cord is manifest by the contraction of the muscles of the body and limbs; but during the passage of the cur-

\* Quoted from Luschka and *Anatomie des Menschen*, vol. .iii., 2, p. 154, by Althaus. Third edition, p. 139.



rent no contractions are observed, and a paralyzing effect soon takes place. The cord remains insensible to any stimulus that may be applied to it as long as the current is passing, but at its cessation any mechanical irritation will give rise to the usual tetanic convulsions. This diminution of excitability is confined alone to the spinal cord, for if the motor nerves and muscles are traversed by an induced current (while the cord is under the influence of the galvanic) they contract vigorously. The galvanic current applied through the spinal cord for a long time produces paralysis.

According to Mayer, if a mild faradic current be applied to the cervical region of frogs that are in an irritable condition, movements of the lower extremities occur. Electrization of the posterior columns produces these movements easier than electrization of the anterior columns. If the posterior columns are removed no movements occur. If the cord is divided into halves, posteriorly and anteriorly from above nearly down to the origin of the sciatic nerve, electrization of the posterior half produces movements, but electrization of the anterior does not. If the posterior roots on the trunk of the brachial nerve are electrized, the movements are produced just as when the cord itself is electrized. Fick, however, declares that the anterior columns respond to faradization.

*Cilio-spinal Centre.*—The cervical sympathetic nerve, which animates the radial fibres of the iris, takes its rise from the spinal cord between the seventh cervical and the sixth dorsal vertebræ.

If this portion of the cord be galvanized, the excitation is transmitted to the cervical sympathetic nerve, and thence to the iris, producing dilatation of the pupil. This point has been termed by Budge and Waller the *centrum cilio-spinale*. A ganglion near the fifth lumbar vertebra which, on being electrized in animals, produces contractions of the rectum and bladder, is called the *ganglion genito-spinale*.

The first of these points, the *centrum cilio-spinale*, can be demonstrated by external applications both of the galvanic and faradic currents, and is of great importance in general faradization. The *ganglion genito-spinale* also is probably directly, though not so demonstrably, affected by external electrization of the spine.

## CHAPTER V.

### ACTION OF ELECTRICITY ON THE SYMPATHETIC AND PNEUMOGASTRIC.

IN order to intelligently appreciate the experiments that have been made to determine the action of electricity on the sympathetic and pneumogastric, it is necessary to keep constantly before the mind the following considerations :

1. The action of electricity on the sympathetic and pneumogastric must be modified by the kind of electricity employed, by the strength of the current and length of the applications, and by the condition and temperament of the subject in which the experiment is made.

To say that galvanizing the sympathetic produces such and such effects is really to give no information whatsoever, for at once the inquiring soul raises the questions, How strong were the currents used? How long were the applications? Were men or animals subjected to the experiment? Were they intact or injured? If animals, what kind, and were the results the same on several animals of the same kind?

2. These nerves can be affected both by external and internal applications of electricity.

The fact that external electrization affects these nerves, which has by some been disputed, is fully apparent from what is known in general of the electro-conductivity of the body, is confirmed by special experiments, and is demonstrated by observations in physiological and pathological cases. This is true not only of the cervical sympathetic ganglia, but of all the ganglia of the body. Known facts in regard to the electro-conductivity of the body show that none of the ganglia of the sympathetic can escape the electric influence when the current is applied over the surface of the body.

3. The effects of external application through the skin on these nerves cannot be expected to be identical in kind and degree with the effects of direct application to the nerves themselves. Although the cervical ganglia of the sympathetic and the pneumogastric nerve are traversed by the currents of electricity when the electrodes are placed on the skin in such a position that the current in passing from one to the other finds these

nerves in their pathway, yet on physical or physiological principles we cannot expect the same results as when the one or both poles are directly applied to the nerves. In external applications it is the *derived* currents that pass through the nerves, and direct *polar* effect is not gained. When we consider that the currents in passing from one pole to the other diffuse themselves into numberless undulatory, diverse currents, it is easy to see that only a small part of the electric influence will be appreciated by such small nerves as the sympathetic ganglia or the pneumogastric. In the body between the electrodes the currents act like diffused light; at the electrodes the currents act like light concentrated to a focus. If currents of sufficient power could be borne externally, it is possible that by single external applications there could be produced all the effects that are obtained by direct applications to the nerves themselves; but this is hardly probable, for the twofold reason that the differential polar effect could not be obtained, and that the great stimulation of each of the electrodes on the surface would complicate the experiment. These considerations, as it seems to us, sufficiently explain what to many has been regarded as a great difficulty—that the ordinary therapeutical measures for electrizing the sympathetic do not produce the same effects as direct applications to the ganglia.

That the sympathetic and the pneumogastric are traversed by the current when the electrodes are placed on the surface of the neck, is sufficiently probable from the known laws of electric conduction. When one electrode is placed at the nape of the neck, and the other at the anterior border of the sterno-cleido-mastoid muscle, the current, whether faradic or galvanic, however widely it may radiate, and however numerous the branch-currents may be, must by physical necessity traverse the sympathetic and pneumogastric. There is no more probability that it will go out of its way, in violation of physical laws, and avoid these nerves, than that a storm sweeping between New York and Brooklyn will take a circuitous march and avoid the East River.

These nerves—the sympathetic and pneumogastric—and the tissues by which they are surrounded, are good conductors, very much superior in conductivity to the skin, and of almost the same conductivity as the muscles; and even if some branch or derived currents pass through other tissues, as unquestionably is the case, these nerves cannot be wholly avoided, and when the electrodes are in central positions they are probably the highway through which nearly the entire charge passes.

But stronger than the analogies of electro-physics, and more con-

vincing than experiments on the dead subject, are the observed effects of electrization of the neck in physiological and pathological cases. These effects, which will be detailed further on, harmonize so closely with all our knowledge of nervo-physiology, and accord so exactly with pathological observation, as to demonstrate beyond doubt, and with an emphasis by which those who observe cannot fail to be impressed, that the sympathetic and pneumogastric can be affected by external faradization or galvanization of the neck.

4. It is difficult, if not impossible, to affect the cervical sympathetic or the pneumogastric by external applications, without at the same time affecting the depressor nerve, the spinal cord, or the brain, and especially difficult is it to limit the action to the pneumogastric without at the same time affecting the sympathetic, and *vice versa*.

This conclusion follows as a logical result from the anatomical relation of the parts and from what is known of the electro-conductivity of the body, and is pretty distinctly demonstrated by the physiological and therapeutical action of the current when externally applied. In whatever position we place the electrodes, the derived currents, in passing from one electrode to the other, must traverse some portion of both of the great nerves. The base of the brain and the region of the neck constitute the most important part of the central nervous system. So far as life can be said to have any centre, it is here, where the pneumogastric, the phrenic, and the other great nerves take their origin. Directly or indirectly, by the actual passage of the current, or by reflex action, any part of this important region is liable to be affected in the applications employed in the so-called galvanization of the cervical sympathetic.

It is partly on account of this difficulty of limiting the action of the current to one or other of these great nerves that we treated them both under the same chapter. When operating on these nerves, exposed and laid bare and isolated, the action of the current can, of course, be limited pretty exclusively to the nerve operated on. The cervical ganglia of the sympathetic receive the chief attention in all these observations, because they are prominent and accessible and bear a powerful and recognized influence over the cerebral circulation; but all the ganglia of the sympathetic are accessible to the electrical influence.

*Action of Electricity on the Cranial Portion of the Sympathetic.*—In 1727 M. Pourfour du Petit discovered that the following symptoms resulted from division of the cervical filaments of the sympathetic nerve, viz. : contraction of the pupil, redness and injection of the conjunctiva, and flattening of the cornea; the eyelids approach each other, the

nictitating membrane becomes more prominent, the secretion from the mucous surfaces of the eye is increased, and the eyeball is drawn further into the orbit. In addition to these symptoms, the ears and nostrils also become red and injected, and the head hotter and more sensitive.

Claude Bernard observed that not only did all these phenomena disappear when the cranial portion of the nerve was submitted to electrization, but that quite reverse phenomena appeared. The pupil became larger than natural; the conjunctiva, the ears, and the nostrils became quite pale; the eyeball protruded from its orbit; the mucous surfaces became drier, and the head cooler and less sensitive; but as soon as electrization was discontinued, all the phenomena caused by the section of the nerve again appeared.

Electrization of the great sympathetic *before* it is divided produces almost precisely the same results as after division. It has been observed by Weber, that if either the inferior cervical ganglia of the sympathetic nerve or its cardiac branches are submitted to electrization, the action of the heart is accelerated.

*Action of Electricity on the Cephalic, Thoracic, and Abdominal Ganglia.*—Section of the sympathetic causes, as we have seen, increase of heat in the ear.

Now if the *cephalic* end of the divided sympathetic is electrified, the increased temperature of the part is lowered; but if the electric current be passed through the large diameter of the ear, the temperature is further increased. On the other hand, if there has been no division of the sympathetic, and the ear is electrified, the heat in that part is lessened.

Valentin found that the galvanization of the superior thoracic ganglia revived the pulsation of the heart after it had ceased, and increased the frequency of the beats when already in action. Mild galvanization of the splanchnic nerves that arise from the six lower dorsal ganglia of the sympathetic increases, while strong galvanization diminishes, the peristaltic action.

*Effect of direct Electrization of the Pneumogastric and on the Respiration.*—MM. Arloing and Tripier have shown that section of the pneumogastric below the medulla oblongata so far modifies its irritability that the action of the heart is not arrested, or but for a short time, by the faradization of the distal end of the cut pneumogastric.

The same authors believe that weak faradic currents cause a slight increase in the rapidity of the beats of the heart and elevation of the blood-pressure in the arteries.

They found that the right pneumogastric has a more powerful influ

ence over the heart than the left. Faradization of the peripheral end of the divided pneumogastric causes arrest of the action of the heart, sudden irregularities of its rhythm, and some diminution of pressure. Faradization of the central end causes retarded and diminished pressure.

According to MM. Arloing and Tripier, faradization of the *intact* pneumogastric with *feeble* currents does not accelerate respiration; faradization with medium currents causes sudden inspiration and forced expiration; faradization with strong and powerful currents causes reflex coughing and vomiting. The same observers found that the left pneumogastric has a more powerful influence over respiration than the right.

The discovery that the *right* pneumogastric has a greater power over the heart than the left, was made by Masoin, of Belgium, about the same time as it was made by Arloing and Tripier. Masoin found the movements of the heart were stopped by the galvanization of the left pneumogastric. It was possible to restore the movements by a mechanical excitation, such as striking the heart with the finger; but after the movements were stopped by galvanization of the right pneumogastric, it was not possible to restore them in that way.

Dr. Brown-Séguard \* states that he has found the same differences to exist in men as in animals, judging from experiments made not by electricity, but by pressing on the nerves near the angle of the jaw.

*Arrest of Respiration by Galvanization of the Laryngeal and other Branches of the Pneumogastric.*—It has been shown by Brown-Séguard † that electrization of the upper or the lower laryngeal nerves causes arrest of the respiration, and Bidder has shown that a reflex spasm of the glottis may be caused in the same way. Electrization of the œsophagus and pharynx may sometimes produce the same effect. If the upper laryngeal nerve is electrized after the chest is opened, the arrest of the respiration does not take place as easily as when the chest is not open. The respiration, when thus arrested, usually returns in the course of a quarter or half a minute, whether the electrization is continued or not.

The effect of electrizing the pneumogastric on the respiration is modified by two factors—the portion of the nerve that is electrized and the strength of the current. Mild galvanization of the pneumogastric in the lower part of the neck may increase the respiratory move-

\* *Archives of Scientific and Practical Medicine* January, 1873, p. 92.

† *Loc. cit.*, p. 96.

ments; weak electrization in the upper part of the neck, near the origin of the nerve, may arrest respiration.

A mild current may increase the respiration or diminish it, or it may have no effect whatever.

A medium current may arrest respiration and cause spasm of the glottis and of the muscles of inspiration.

A powerful current may paralyze the diaphragm, and may produce death without the accompanying symptoms of agony.\*

*Coughing.*—A prominent effect of electrizing the pneumogastric is *coughing*. This symptom may be excited by external as well as by internal applications, and by the faradic as well as by the galvanic current.

We made our first experiments in this direction in 1867. Dr. Rockwell then observed that the application of either pole of a strong faradic current to the nape of the neck—the other pole being at the feet, or in either hand, or at the pit of the stomach—excited in sensitive patients quite severe attacks of coughing, that lasted so long as the pole remained in position. Most clearly this effect was seen in thin and sensitive patients. It was not necessary to be particular in regard to the position of the pole on the neck in order to excite this symptom; not only in the cilio-spinal centre, but even when the pole is as low down as the first and second dorsal vertebræ, the laryngeal branches of the pneumogastric may be so irritated as to induce coughing.

This phenomenon we daily observed in the operation of general faradization. The same effect follows the use of *strong* interrupted galvanic currents.

According to Donders, the pneumogastric, when acted upon by the *galvanic* current, conforms to Pflüger's law of contraction; in the region of anelectrotonos its irritability is lessened; in the region of catelectrotonos its irritability is sometimes increased.

*Action of External Applications of Electricity on the Pneumogastric and Cervical Sympathetic of living uninjured Men.*—The experiments above recorded were made chiefly on the *exposed* nerves of animals, and the applications were made directly to the nerves by one or both poles. Keeping in mind the considerations previously adduced, we proceed to examine into the effect of external applications of electricity on the cervical sympathetic and the pneumogastric of living men in health.

In our attempts to solve the problem, we have experimented on a

\* *Archives of Scientific and Practical Medicine*, No. 1, 1873, p. 96. Whether these experiments were performed with the faradic or galvanic current is not distinctly stated.

large variety of individuals of different ages and by different methods of application. One of the electrodes is placed in the mastoid fossa, and the other over the seventh cervical vertebra, or at the top of the clavicle. Both directions of the current are used. We used in these experiments a zinc carbon, or the Smee's battery, of from 5 to 30 cells, from 1 to 5 or 10 minutes.

The general results of our researches may be thus summed up :

1. *A slight feeling of drowsiness.* This sometimes began to be perceptible shortly after the electrodes were applied, increased up to a certain point, and continued for some little time after the *stance* was over. In many cases it is not observed until the lapse of five or ten minutes after the *stance*. The feeling, which was by no means constant, was usually so slight that it might not have been observed, had we not in our experiments kept closely on the watch for every sensation experienced during or just after the application.

Some individuals are amazingly susceptible to this soporific effect of galvanization of the neck. A young lady whom we were treating for facial acne by central galvanization, was frequently put right to sleep *within one minute* after the application began. Her eyes would close and her head would droop and nod ; and when the electrodes were removed she would awake but slowly, and with a vacant look and drowsy feeling, such as we all experience when we are suddenly roused from a nap. This effect followed any sort of application around the neck with either pole and in any direction.

On the accepted theory that a state of cerebral anæmia predisposes to sleep, we should reason, *à priori*, that electrization of the sympathetic ought to induce a feeling of drowsiness, since on some individuals it unquestionably diminishes the current of blood in the brain, and experimentally we have found that it does thus induce a slight and temporary disposition to sleep, although this result is probably far less marked than it would be if, without injury to the living subject, the application could be made directly to the ganglia, and this effect is by no means uniform, but varies with the strength of the currents and with the temperament of the individual.

2. *A feeling of warmth through the system with sensible perspiration.* This was not a constant symptom, though it was oftentimes very decided. To produce sensible perspiration usually requires a strong current and a long application. The extent to which this was felt was manifestly dependent on the strength of the current and the length of the application. It was usually felt but a short time after the *stance* was completed. We have observed this effect more frequently and



more markedly in the susceptible and nervous than in the cold and phlegmatic, and most frequently in more or less pathological cases.

3. *A marked effect on the pulse.* The pulse was sometimes accelerated, but more frequently lowered, two, three, four, or more beats.

In order to determine the effects of electrization of the sympathetic on the pulse, we made the examinations immediately before and immediately after the applications. Every precaution was taken to avoid error, by allowing an interval of rest before the sitting, in order to give time for the subsidence of the pulse to its natural condition from any excitement that it may have received from the exertion of walking or the labor of partially disrobing. In cases of doubt the whole minute was counted, in some instances several times in succession. A patient unaccustomed to the sensation produced by the electric current, or to the *modus operandi* of its employment, might experience an acceleration of the pulse from simple mental excitement, not only prior to or at the commencement of the sitting, but also during or after the application. Error from this cause was in our cases manifestly impossible, and all the others on whom we experimented with a view to obtain physiological results were so well familiarized to the medical employment of electricity that they would receive any treatment proposed with cool indifference. In order still further to guard against error, and at the same time to observe the continuance or permanency of the effect of the experiments, we repeated, in some instances, our examinations of the pulse at intervals of fifteen minutes or half an hour after the sitting was over.

A corroborative evidence that these changes in the pulse were due to the action of the current, and not to mental excitement, is found in the fact that, after an interval of five, ten, or fifteen minutes, the pulse returned to its original condition.

These changes in the time of the pulse were also accompanied by perceptible changes in its character, which, if careful sphygmographic observations had been made, might perhaps have been reduced to some general law.

Eulenburg and Schmidt found that when the positive pole of from twenty to forty of Daniell's elements was placed at the *manubrium sterni*, and the negative pole in the auriculo-maxillary fossa, the pupil of that side was at first slightly dilated and afterwards contracted. These changes in the pupil are by no means uniform in their appearance. In some cases they appear at once after closing the circuit, and in others after the lapse of half a minute or minute, and in others after interruptions. These phenomena are liable to

many variations, according to the strength, length, and locality of the applications. If an electrode is placed in the auriculo-maxillary fossa of each side, the changes in the pupil occur on both sides, but are more marked on the side on which is the negative pole. The same application, continued for some time with a strong current, reduced the normal pulse from 4 to 16 beats a minute and the pathological pulse even more, diminished the tension in the carotid and vertebral arteries, and markedly altered their sphygmographic tracings. The same observers found that galvanization of the spine also diminished the beats of the pulse.

*Effect of External Electrization through the neck on the Retinal Circulation.*—In order to determine the effect of external applications of electricity through the neck on the retinal circulation, we have made many experiments with the aid of a number of leading ophthalmologists.

These experiments, which have been frequently repeated with different individuals, with different strengths of current, and with different batteries, seem to us to demonstrate the following propositions: \*

1. Galvanizing or faradizing the region of the cervical sympathetic has a marked temporary influence over the retinal circulation. It may cause contraction of the arteries or dilatation of the veins.

2. The faradic current produces precisely the same effects on the retinal circulation as the galvanic, only more slowly. The physiological difference between the currents in this respect is therefore a difference of degree and not of kind.

3. Mild currents and short applications caused contraction of the blood-vessel of the retina, while strong currents and long applications caused dilatation. Much seemed to depend *on the temperament and condition* of the individual. *What would cause contraction in one would in the other cause dilatation.*† These varying effects correspond with clinical experience.

4. When the patient on whom the experiment is made is in an excited or irritable condition from any cause, or from previous electrization, even a mild current will sometimes cause dilatation at once, without any early contraction.

\* The ophthalmologists who observed the retina in these experiments were Drs. Roosa, Hackley, Loring, Matthewson, Prout, and Newton, to all of whom we desire to return our acknowledgments.

† The opposite and contradictory results obtained by different observers who have studied the effects of chloral, bromide of potassium, etc., on the retinal circulation, may be similarly explained.

5. The contraction which takes place is sometimes followed, a few minutes after the close of the *stance*, by dilatation which is greater than normal.

6. The dilatation which takes place is sometimes followed by contraction after the close of the *stance*.

In some of the experiments no effect on the retina could be detected. Impressible and nervous temperaments seem to exhibit changes in the vascular condition of the retina much more readily than cold and phlegmatic temperaments.

The question now arises, Whether these changes in the retinal circulation were due to the effect of the current on the sympathetic or on the pneumogastric, or did they take place through the spinal cord or by reflex action?

This question is answered by comparing the results of these experiments with the result of experiments made by Duchenne and Prof. Leigeois, of Paris. These gentlemen laid bare the cervical sympathetic in a rabbit, and electrized it with both currents in the same manner that we electrized the necks of the individuals on whom we experimented. The results on the circulation in the rabbit's ear were in every distinctive feature identical with the results on the retina when the galvanic current was passed through the neck of the living human subject.

The other effects of galvanizing the region of the cervical sympathetic—disposition to sleep, sweating, increased circulation in the extremities, etc.—seem to confirm these physiological observations.

These experiments have been partially confirmed by Onimus, who has shown that the circulation of the retina may be influenced by galvanization of the cervical sympathetic. He observed hyperæmia, but this, as we have shown, is not a constant effect.

*Experiments with the Sphygmograph.*—We have made experiments with the sphygmograph, with the assistance of Dr. L. De Forest Woodruff.

For assistance in the study of sphygmography we are under obligations to Dr. Roger S. Tracy. A few samples of the observations are represented in the cuts.



No. 1.—Normal pulse.



No. 2.—After five minutes' galvanization of the sympathetic.

## ELECTRO-PHYSIOLOGY.



No. 3.—After ten minutes' galvanization of the sympathetic.



No. 4.—Five minutes after the close of the séance of galvanization of the sympathetic.



No. 5.—After five minutes' faradization of sympathetic



No. 6.—After nine minutes' faradization of sympathetic.



No. 7.—After twenty minutes' faradization of sympathetic.



No. 8.—After fifteen minutes' general faradization.



No. 9.—Five minutes after close of séance of general faradization.

From these experiments we derive the following conclusions :

1. Both currents—faradic and galvanic—when applied in such a way as to traverse the region of the neck in which the pneumogastric and cervical ganglia of the sympathetic are situated, markedly affect the pulse.

2. The effect is chiefly shown in abruptness of the systole, and in abruptness of the diastole, and in shortening of the interval between the cardiac impulse and the arterial impulse. In general it may be said that the force of the pulse is increased. Its rapidity may be either increased or diminished, according to the length of the application and the strength of the current, and analogy would lead us

to believe that the effect must widely vary with the individual. The arterial impulse increased probably from the effect on the vaso-motor nerves.

3. The effect of general faradization was to prolong the systole and the interval between the cardiac and the arterial impulse. The abruptness, and the systole that is so marked during and after faradization through the neck, was not observed after general faradization. A calming, soporific influence is very frequently produced by general faradization, and the effect on the pulse harmonizes with this observation.

4. These effects on the pulse gradually pass away, but are distinctly traceable for a number of minutes after the electrodes are removed.

The effect of the current thus applied on the circulation is probably a complex resultant of the effect of the electricity on the pneumogastric, the sympathetic, the depressor, and the spinal cord. To differentiate these effects is manifestly impossible.

In this connection are to be noted the later investigations of Dr. Fischer,\* of Munich, on the effects of electrization of the sympathetic. He experimented on horses and cats, irritating the nerve *directly*, with the twofold object of studying the blood-tension in the cerebral vessels and the changes in the size of the pupil. The general results of these efforts confirm observations previously made, and especially our statement as to the impossibility of accurately localizing currents in any ganglia by simple external applications. *Direct* faradization of the sympathetic increased the blood-pressure and tension of the artery, and increased the frequency of the pulse. The same phenomena were observed under galvanization, but in a less degree. Faradization of the exposed sympathetic caused very marked reactions in the pupil, while galvanization of the nerve produced comparatively little effect. When, however, the sympathetic and vagus were simultaneously submitted to the influence of galvanism the reactions of the pupils were very marked. Simultaneous faradization, however, was followed by no alterations.

\* *Schmidt's Jahrbücher*. No. 4.

## CHAPTER VI.

### ACTION OF ELECTRICITY ON THE NERVES OF SPECIAL SENSE.

*Action of the Galvanic Current on the Optic Nerve.*—The galvanic current, when applied to the eye, causes both *flashes of light and perception of color*.

If one electrode is placed on the tongue, or on any part of the mucous surface of the mouth or nose, and the other on any part of the surface of the body, the flash is readily perceived.

The character of these flashes is variously modified by the strength of the current and the suddenness of the interruption. The temperament of the patient also modifies the reaction, and the effect of the two poles is usually quite different.

We have studied this subject with various strengths of current, and on subjects of both sexes differing widely in age and temperament.

In one subject—a young man of nervous temperament—the positive pole placed over the eye, with a medium current from ten zinc-carbon cells, caused a white central spot, with a light areola. The white central spot varied in shape between that of a quarter or half to a full moon. When the negative pole was placed over the eye, the central spot appeared of a bluish or purplish color, and the areola was the same as under the positive pole. In both cases the areola seemed to consist of waves of light radiating from the centre toward the periphery.

In making these experiments, the pole that is placed over the eye is armed with a soft sponge, and is pressed firmly on the closed lid, while the other is applied at the back of the neck, or is held in the hand of the subject.

In another subject, a young physician of good health, and nervo-sanguine temperament, the positive pole from a current of six cells caused a central disk of a pink color, and from this spot violet waves radiated through the areola. The pink disk appeared when the current was closed, the violet areola flashed out when the current was broken. The negative pole produced reactions every way similar. This subject could not bear very strong currents.

Several other physicians on whom we experimented could not distinguish any central disk, but all could readily see the light areola.

The conclusions from the above, and numerous similar experiments made in different individuals, are as follows :

1. A mild as well as a strong galvanic current applied to the eye, and interrupted, causes a flash or glimmer of light to appear.
2. A medium or strong galvanic current causes, in addition to the flash of light, a distinct central spot of varying shape, and both the central spot and the areola may be of various colors, as pink, purple, yellowish, and violet.
3. With some individuals, though not with all, the colors of the central spot and of the areola, and their relative arrangement, appear differently under the two poles, and also differently at the closing and opening of the circuit.
4. All those reactions, like all other electro-physiological reactions, are variously modified by the temperament of the individual operated on and by the strength of the current.

The above conclusions, as will be seen, differ somewhat from those of Helmholtz and others who have studied this subject. The differential action of the ascending and descending currents we have not been able to demonstrate, and see no way of demonstrating. We believe that here, as in so many other electro-physiological and electro-therapeutical procedures, the differential polar action has been confounded with the differential action of the ascending and descending currents.

Although the above reactions in their full degree can be most conveniently obtained by placing one electrode over the closed eye, and the other in the hand or at the back of the neck, yet the general reaction of the glimmering flash of light can be obtained by placing one electrode in the vicinity of the eye, or on any part of the face or beard, or in the mouth. In susceptible persons the flash comes from interrupted galvanization of the neck or spine.

*Faradic Current.*—The current from the primary or secondary coil of the ordinary faradic machines has little or no perceptible effect on the retina, as we have demonstrated by various experiments. We have found, however, by repeated observations, that the current from the *long* coils of the electro-magnetic machine manufactured by Kidder has a most decided action on the retina. The peculiar construction of the coil of this machine will be described in the chapter devoted to apparatus for electro-therapeutics. It is sufficient here to say that it is composed of three or four or more coils of insulated copper-wire, the

inward coil being short and thick, and the others gradually increasing in the length of the wires. These coils are not separate and distinct, as in ordinary machines, but connected, and are, so to speak, *tapped* at the points of union, so as to obtain a number of currents varying in quantity, tension, and physiological power. It is from the *fourth* and *fifth* coils, which are not furnished to the majority of his smaller machines, that we obtain the reaction of the retina that we are now to describe. The reaction is best obtained by placing a medium-sized sponge electrode, well moistened, over the closed eye, or very near to the eye, while the other electrode is held in the hand or applied to some indifferent point, as the back of the neck, or arms, or feet. With a current of moderate strength thus applied, a circle filled with wavy, undulating light, or whitish spots or figures, appears. It is difficult to convey in language a precise description of this appearance. If snow-flakes could be elongated somewhat, and made to coil about in various directions, they would give a good idea of this reaction. If we look through a window at a thick, driving snow-storm, with large flakes, we can get a not very incorrect notion of the reaction, as we have over and over again demonstrated on ourselves and others. So far as we have been able to see, bright or variegated colors do not appear, except from the current of the *fifth* coil. The negative pole gives a stronger reaction than the positive; but not appreciably different in character. This reaction of the fourth coil of this machine is utterly unlike that which is obtained from either pole of the galvanic current. This effect has long been shown by the inventor of this machine, and has been illustrated by him. We were induced to question his assertions until we had first made experiments of our own with the different coils of the machine.

*The Effect of Electrical Irritation compared with Mechanical Irritation of the Eye.*—It is interesting to compare the reaction produced by the galvanic and faradic currents on the retina to the effects of mechanical irritation. We have found by experiment on ourselves that rubbing the eyes when closed, or partially closed, causes various and oftentimes beautiful appearances. Very frequently a central spot will appear, varying in shape and color, and changing in shape and color during the irritation. All conceivable shapes, and every grade of color, we have seen in this way over and over repeated; sometimes a mere circle of light shading off into darkness, and again a definite and well-formed object, brilliant in color, standing forth clear and beautiful against the dark background. Forms resembling a bouquet of flowers, or a cluster of stars, or various shapes of crystals, appear with such



vividness that we love to prolong the experiment. Simple pressure on the side of the eyeball will cause reactions somewhat similar in kind (though less in degree) to those produced by the faradic current.

These reactions, however, are not constant; they vary greatly with the individual, and with the same individual at different times. In order to obtain the most beautiful appearances, it is necessary to first look for a moment on bright light, or to have the eyes open in the full sunlight. It would seem that the retina must first become sensitive, by exposure to strong light, before the reactions can appear in their full extent.

*Action of Electricity on the Auditory Nerve ; Action of the Faradic Current.*—The faradic current, when applied to the ear, or in the vicinity of the ear, causes a ringing, or humming, or rumbling sound, according to the method of application and the strength of the current. These sounds are due, in part, to the *susurri* of the muscles.

*Action of the Galvanic Current.*—To the galvanic current the auditory reacts by certain fixed laws.

This normal formula is as follows :

Ka S Kl, distinct accented sound.

Ka D Kl >, sound disappearing by degrees.

Ka O —, no sensation of sound.

An S —, “ “

An D —, “ “

An O Kl, weak and short sound, similar in character to Ka S.

In the above formula, Ka = Kathode (negative pole), An = Anode (positive pole), S = closing (schliesung), O = opening (oeffnung), D = duration of current.

Pf = whistling sound.

Kl = ringing “

Z = hissing “

The sensations with Ka S appear sooner and stronger than with An O.

This formula, it will be observed, harmonizes with the law of electrotonos (see p. 111), and Pflüger's contraction law—that “*a nerve is stimulated by the appearance of catelectrotonos and the disappearance of anelectrotonos ; not, however, by the disappearance of catelectrotonos and the appearance of anelectrotonos.* (See p. 116).

Although the character of sounds varies with the strength and continuance of the current and with the individual, yet in the healthy ear the *polar effects* never vary.

*There is never any sensation of sound with the closing of the anode (An S), except in pathological conditions.*

The *polar effect* is therefore the leading effect, and the *direction* of the current through the auditory nerve appears to have no demonstrable influence.

The use of the rheostat and the changes in the reactions that are made by interposing the various grades of resistances in the circuit are represented in the following experiments of Brenner : \*

The experiment was performed on a healthy ear that had been cured a short time before of a catarrh of the middle ear. The number of elements is in *Roman*, the number of resistances in *Arabic*.

XX 10-80 gave no reaction.	XX 260-400 Ka S—Rumbling of cannon.
XX 90-120 Ka S—Buzzing of flies very short.	Ka D—Same >
Ka D —	Ka O —
Ka O —	An S —
An S —	An D —
An D —	An O—Rumbling of wagons.
An O —	
XX 130-170 Ka S—Stronger buzzing.	XX 410-550 Ka S—Striking of metallic plate.
Ka D—Same.	Ka D—Same >
Ka O —	Ka O —
An S —	An S —
An D —	An D —
An O —	An O—Rumbling.
XX 180-250 Ka S—Distant rumbling of wagons.	XX 560- Ka S—Sharp ring like a silver table bell.
Ka D—Same.	Ka D—Same >
Ka O —	Ka O —
An S —	An S —
An D —	An D —
An O—Buzzing of flies.	An O—Weaker and shorter ringing.

Erb † gives the following result of experiments on himself :

\* Op. cit., Band i., p. 105.

† *Archiv Ophthalmology und Otolog.* Vol. i., No. 1, p. 246.

10 El Ka S Kl ———	8 and 6 El Ka S Kl
Ka D Kl >	Ka D ———
Ka O ———	Ka O ———
An S ———	An S ———
An D	An D ———
An O Kl	An O ———

On another patient,\* 50 years of age, he obtained the following reaction with accompanying symptoms of pain and facial contortions :

- 8 El Ka S—Clear whistling, stinging pain and facial contortions.  
 Ka D—Gradually disappeared.  
 Ka O—No sensation.  
 An S—Violent pain.  
 An D—Pain remains.  
 An O—Short and weak whistling ; slight facial convulsions with 10 El ; the same formula gave still louder sensations of sound, but the accompanying pain was very severe.

Brenner † gives the following reaction in a healthy man :

Ka S—Rumbling of cannon.	Same patient treated by a stronger current.
Ka D— “ “	Ka S—Sharp ringing.
Ka O ———	Ka D— “ “
AS ———	Ka O ———
AD ———	AS ———
AO—Rumbling of wagons.	AD ——— [ing.
	AO—Weaker and shorter ring.

The variations of the tone with the difference of the current are represented in the following experiment of Brenner : ‡

With the Cathode closing.	With Anode opening. (An O.)
XX 10 Ka S K.	XX 30 A O K.
20 Ka S K.	40 A O K.
30 Ka S K.	50 A O K.
40 Ka S K'.	60 A O K.
50 Ka S K'.	70 A O K.
60 Ka S K'.	80 A O K'.
70 Ka S K''.	90 A O K'.
80 Ka S K''.	100 A K'.

*These Reactions produced directly and not by Reflex Action.—We*

\* Loc. cit., p. 250.

† Op. cit., Band i., p. 106.

‡ Loc. cit., p. 110.

thoroughly agree with Brenner and Erb that these reactions of the auditory nerve are obtained by the *direct* action of the current on the nerve, and not by *reflex action* through the trigeminus. This view is proved by the general fact of the conductivity of the tissues of the brain (see chapter on that subject), by the fact that even when the trigeminus is paralyzed the reaction may yet occur,\* and by the fact that when the electrode is placed in a condition favorable for the entrance of the current into the ear, the reaction is more decided than when the electrode is placed in a condition favorable for the excitement of the trigeminus, but unfavorable for the direct entrance of the current, as has been conclusively shown by Erb† and by ourselves.‡ We have removed the pole from the *tragus to the malar bone and the cheek, both of which points are highly favorable for the excitation of the trigeminus, and have found that with removal the reaction diminished or disappeared.*

In order to obtain that normal formula, the following conditions are necessary :—

1. *Convenient galvanic apparatus.*

A very powerful galvanic battery is not needed. The range of elements to which the auditory nerve sensibly reacts is between 2 to 30. In some cases quite strong currents are necessary. The galvanic batteries and electrodes described in this work are adapted for these investigations. There should be a current reverser; and a rheostat, though not exactly indispensable, is yet very convenient.

2. *A right method of application, and practice in using it.*

On the whole, the best method of application to produce these reactions is the *external* arrangement, in which one pole is firmly pressed on the tragus (the ear external auditory canal having been previously filled with warm salt water), while the other is held in or fastened on the hand on the opposite side. Any convenient electrodes may be used for these purposes. So long as the pole whose specific effect we desire to produce is on the right place in the ear or on the tragus, the position of the other electrode is not absolutely essential, provided it is somewhere *on the opposite side, so as to allow the current to pass through the auditory nerve.* It is difficult or impossible to get the reaction while the pole is on the mastoid process of the same side. It

\* Vide Moos' case, above quoted in Archiv Ophth. und Otol., vol. i., No. 2, p. 482.

† Archiv Ophth. und Otol., vol. i., No. 1., p. 261 et seq.

‡ For a detailed discussion of this subject, see Brenner's work, Band i., 1 Abth., p. 94, et seq.

has been shown that when both poles are placed in the auditory canal, by means of a double electrode, the auditory nerve reacts to the nearer pole.

*A number of intelligent and practised patients with both healthy and diseased ears.*

The advantages of intelligence on the part of a patient are obvious ; just as in investigating electro-muscular sensibility, it is necessary to depend entirely on the statements of the patient for our information. Even the strong-minded and intelligent are sometimes so distressed by the pain produced by the applications, or so distracted by the sensations of *dizziness*, and the *contractions of the facial muscles*, that they are unable to rightly interpret their subjective sensations in the ear. It is necessary that the experiments should be made on a number of patients, in order to obtain the variety of reactions above described.

It is best also to make the first experiment on patients who have diseased ears, for it is as true of the auditory as of the nasal passages that they sometimes become less sensitive when diseased. This is to be explained partly by the manipulations and treatment to which such patients become accustomed, and partly by the fact that the morbid process itself produces callousness of the parts.

The operator should proceed calmly and with self-command. After the patient is in position, with his head inclined on the back of the chair or lounge, and one of the electrodes fastened to or held in the hand opposite the ear to be experimented on, a little warm salt water should be dropped in (which can be very conveniently done by squeezing the small quantity necessary to fill the external auditory canal from a small sponge or from a teaspoon or funnel-shaped glass \*) and the other electrode firmly pressed on the tragus. It is well to begin with a small number of elements, and gradually increase until a reaction is obtained. The reaction will usually appear when the current is strong enough to produce contractions of the facial muscles. The patient should all the time be continually and *repeatedly* questioned in regard to the sensations experienced, especially if he is unaccustomed to the treatment, for at first he may be so distracted *by the flashes of light before the eyes, the contractions of the facial muscles, the nausea, the metallic taste, and the noise of the water in the ear*, and especially by the *pain*, that he may be unable at first to distinguish the true character of the reaction.

\* It is well to place a towel about the neck, just as when syringing the ear, so as to avoid wetting the collar or other clothing of the patient.

If the battery is provided with a *commutator*, for increasing and diminishing the number of elements brought into requisition, a *current reverser* for changing the direction of the current without removing the poles, and a *rheostat* for *introducing resistances* into the circuit, the labor of the operator will be materially lightened; *but such appliances are not indispensable.*

The operator should remember that the reactions are modified by the experiment itself. (a.) Ka.S is most effectual after An.S. Therefore the use of *voltaic alternatives* is of service.

(b.) The excitability of the nerve is increased by long closure of cathode (Ka.S.).

(c.) The excitement of An.O. increases with the strength of the current and the length of closure.

It should be remembered also that Ka.S. is stronger and quicker than An.O.

Judging from our own researches in this department these three leading statements of Brenner—that the auditory nerve reacts to the *nearest* electrode in a regular manner, that in health sounds of some kind are produced at the closing and in the duration of the cathode, and that in pathological cases a part of the normal formula is more or less changed—are capable of sufficient and easy demonstration to those who are thoroughly familiar with electro-therapeutical experimentation.

On the other hand, some of the special features of Brenner's system offer difficulties in the way of their successful and uniform demonstration that can only be overcome by careful practice in this special department. To catch the sounds which in health are heard at the opening of the anode; to distinguish between the noise caused by the agitation of the water in the ear, and the subjective sounds that are so frequently the symptoms of disease of the auditory apparatus and the genuine reaction of the auditory nerve; to obtain the *complete* normal formula in health, and to satisfactorily discriminate between the various abnormal reactions of disease—the first attempt to fully corroborate all the assertions in these particulars will usually result in complete or partial failure, especially to those who are unfamiliar with the use of galvanic apparatus.

*Degrees of Irritability.*—Brenner distinguishes three different degrees of irritability of the auditory nerve, according to the number of elements that it takes to excite the reaction. The degrees of irritability may be changed during the sitting by the effect of the current on the nerve, and especially by the voltaic alternatives.

Thus, if at the beginning of the sitting the nerve reacted to 16 ele

ments, but to no number less than that, these 16 elements would represent the primary *irritability* of that nerve.

If by various alternations of the current the nerve is brought into a condition that it reacts to 12 elements, these 12 elements represent the *secondary irritability* of that nerve.

If, by still further excitation, the nerve is made to react to 10 elements, these 10 elements represent the *tertiary excitability* of that nerve.

In opposition to the above conclusions Dr. Wreden, of St. Petersburg, has made a number of experiments which seem to him to establish that the sounds heard during galvanization of the ear are due not to the reaction of the auditory nerve, but to the *contraction of the small muscles of the middle ear*. In his experiments he electrized the Eustachian tube, through the catheter, and also the middle ear, by means of small, delicate, and finely graduated sounds insulated to their points. He believes that by this method he causes contraction of the *tensor tympani* and of the *stapedius*, through irritation of the fifth and seventh nerves.\*

Wreden asserts that during electrization by these methods the membrana tympani is retracted, and believes that this retraction is caused by the contraction of the muscles. This, however, has been denied by Poorten. To settle this question, Löwenberg devised a *manometer*, which consists in a bit of cork or rubber fitted into the external meatus hermetically, and receiving hermetically a capillary glass tube which contains a drop of colored liquid. The external meatus is filled with water, which is connected with one of the poles of a faradic machine, while the other is applied to the skin by a sponge or through the Eustachian tube. When the membrana tympani is retracted by the action of the current, the drop of colored water indicates this retraction by falling, when it is pushed outward, by rising.

Admitting to the full all that has been claimed by Wreden and Löwenberg, we do not see that it proves that the supposed complex reactions of the auditory nerve to electricity are nothing more than muscular contractions. Admitting that in some cases where the membrana tympani is gone, the reactions are not obtained, still the following considerations are, to our mind, convincing:

1. The reactions of the galvanic current, when applied to the ear, are frequently similar to some of the sounds of tinnitus aurium. They are sometimes so much alike that they cannot be distinguished.

\* A résumé of this subject is presented in Dr. Roosa's work on *Diseases of the Ear*, p. 493-495.

2. The differential polar effects of the galvanic current on the ear which are very easy of demonstration, cannot be explained by any theory of muscular contraction.

3. Some of the reactions are produced by the *steady* action of the galvanic current, without any interruption, and with a strength not sufficient to produce muscular contraction; while it is true that certain reactions in some cases require strong and interrupted currents, it is not true of all of them.

4. A reaction of the auditory nerve similar to some forms of tinnitus can be obtained in some sensitive cases, not only by galvanization of the ear, but of the other parts of the head, and even the trunk.

We have had a patient who complained every time we galvanized the spine that buzzing, hissing sounds were excited in his ear. Similar sounds are produced by galvanization of the ear. The effect in this case was probably reflex.

All these considerations convince us that the variety of sounds produced by galvanization of the ear is due to the excitation of the auditory nerve, and that this excitation may be both direct and reflex. We are fully aware, however, that for the present this fact has a greater interest for the electro-physiologist than for the electro-therapeutist.

*Olfactory Nerve.*—We have observed in frequent experimenting on ourselves that the negative pole of a strong galvanic current applied to the Schneiderian membrane caused, in certain sensitive localities, an odor much resembling sulphuretted hydrogen. The odor observed in the neighborhood of docks will perhaps suggest the peculiar character of this reaction more than any formal description. This reaction is obtained only when a powerful current is used. It is obtained at the opening of the circuit, while the circuit is closed and for some little time after the circuit is opened. We have found that this peculiar reaction varies much with the individual, and with the same individual at different times. A sensitive, or even an ulcerated condition of the mucous membrane would seem to form it. Although we are frequently treating cases of rhinitis (nasal catarrh) by internal galvanization with metallic electrodes, yet our patients never speak of this peculiar odor. The mucous membrane of the nasal passages is very sensitive, and in ordinary therapeutical applications only gentle currents will be borne, whereas this reaction of the olfactory nerves demands powerful and painful currents.

The differential reaction of the positive and the negative pole of the ascending and descending currents that were long ago claimed by Ritter, we have not been able to confirm. The phenomenon of sneezing, or a disposition to sneeze, of which Ritter spoke, is due, not to any reac



tion of the olfactory nerve, but to the mechanical irritation of the sensory nerves by the electrode. Sneezing, as all aurists know, is called forth by a single introduction of the Eustachian catheter, and we observe it continually in introducing the nasal electrode. It is observed most, however, just as the electrode is being inserted; and when the current is running, the symptom does not usually annoy us. The action of a gentle current on the sensory nerves of the nasal passages seems rather to have a sedative effect, and in a measure counteracts the tendency to sneeze that is excited by the mechanical irritation of the electrode.

Schönbein suggests that the peculiar smell experienced from the passage of the electric current through the olfactory nerve is caused by ozone that is generated.

This peculiar odor, observed in powerful galvanization of the nasal passage, is unquestionably due to the reaction of the nerve to the electrical stimulus, and corresponds to the effects produced by the same agent on the nerves of seeing, hearing, and tasting.

Franklinic electricity, electro-magnetism, magneto-electricity, are unable, in any strength that can be endured by a person in health, to excite the peculiar reaction of the olfactory nerve.

*Action of Electricity on the Gustatory Nerve—Action of the Galvanic Current.*—In 1754, long before the discovery of galvanism, it was noticed by M. Sulzer that lead and silver, when connected and then brought in contact with the tongue, gave rise to a peculiar taste similar to that produced by vitriol of iron. If we apply a piece of zinc to the upper, and one of silver to the lower part of the tongue, a powerful acid taste will be experienced under the zinc plate, and a slight alkaline taste under the silver plate. These sensations are perceived as long as the circuit is closed; but if the plate or the tongue be warmer or colder than natural, or very much benumbed by acids or other irritating substances, very little, if any, sensation is produced. If the tension of the current be much increased, by using several pairs, the tongue becomes convulsed and a flash of light is perceived. When neither of the electrodes touches the tongue, a metallic instead of an acid or alkaline taste is produced.

The peculiar reaction of the gustatory nerve to the current is generally described by those on whom we have experimented as "coppery," or "sour," or "metallic," or "bitter." Sour or coppery are, we believe, the designations most frequently employed by those persons who experience the sensation for the first time, and who have no theories in the matter to prove or disprove, and who therefore are likely to give their real impressions. If we ask them whether they have

a taste in the mouth while the current is passing, they usually reply that the taste is sour or "coppery," and sometimes they may call it "bitter." If we ask them whether the taste is "metallic," they usually reply in the affirmative. Our observations on this subject have been very numerous, and they have been made with both currents. It is not necessary to send the galvanic current through the tongue or through the chorda tympani nerve, or through the face even; for galvanization of the neck in the anterior and posterior regions, and of the head in almost any direction, and of the spine—the lower as well as the upper region—will be felt in the gustatory nerve.

This metallic taste is felt almost as soon as the galvanic current is closed, grows stronger while the current runs up to a certain point, and is sometimes felt for several minutes after the electrodes are removed. In some temperaments on which we have experimented, the metallic taste remains on the tongue for several hours, and even all day, and longer.

In susceptible temperaments the faradic current produces in a less degree this metallic taste, and that, too, not only when applied to the tongue, but also the head, neck, and spine. In the operations of central galvanization this reaction of the gustatory nerve becomes of considerable value in showing us that the current is passing as we wish it, and that the patient is receiving all that is well for him. The gustatory reaction thus answers the purpose of a galvanometer, showing that the current is passing, and to a certain degree regulating the dose.

There is little doubt that this metallic taste, caused by electrization, is due to a peculiar excitation of the properties of the gustatory nerves by the stimulus of the current.

The theory that it might be of an electrolytic character, and therefore explained by the products of decomposition at the poles—acid at the positive, and alkalis at the negative—Rosenthal, by a variety of experiments, has shown to be untenable.

## CHAPTER VII.

### ACTION OF ELECTRICITY ON MOTOR AND SENSORY NERVES AND VOLUNTARY MUSCLES.

*Irritability of nerves and muscles is that property by virtue of which they conduct the natural stimulus of the body, or external impressions, or respond to artificial stimulation.*

Nerves and muscles are called irritable so long as they retain this property. Irritability of the nerves is a property *inherent in them*. No other tissue except nerve tissue possesses this property.

During life nerves and muscles manifest their irritability by fulfilling all the natural functions that belong to them; it is this property that enables them to conduct that mysterious vital agent, which, in lieu of definite knowledge, we are obliged to call *nerve force*. This nerve force, which is peculiar to living beings, may possibly be correlative to the other forces of nature—light, heat, electricity, magnetism, and gravitation—but the theory that it is identical with electricity is, as will be seen, untenable.

*Irritability, how long Retained after Death.*—The irritability of nerves and muscles begins to diminish after death, and sooner or later disappears. It disappears much sooner in warm-blooded than in cold-blooded animals.

In warm-blooded animals, as the rabbit and the dog, the muscular current may disappear in half or three-quarters of an hour. In the limb of a frog that has been properly protected and under a cool temperature, it may remain for two, three, or even four weeks. It is on account of this persistence of irritability in frogs that they are so frequently chosen in electro-physiological experiments. Irritability also varies with the temperature. It lasts longer in cold than in warm weather, and under extreme heat it remains but a short time.

The local application of poisons and powerful chemical substances, as extract of opium, acetates of strychnine, morphine, creasote, nitrate of silver, mineral acids, rapidly destroys the irritability.

*How Muscular Contractions are Produced.*—There are, then, two

ways by which the muscles can be made to contract under electricity : (1) by acting on the motor nerves, and (2) by acting on the muscles themselves. There is, however, this interesting and important difference in the effect of electrizing the motor nerves and the muscles, that when the former are electrized all the muscles supplied by them contract, and when the muscles are electrized, only that muscle to which the electrodes are applied, or that part of the muscle between the electrodes, will contract. When direct applications to the muscle are made, the best contractions are produced by putting one electrode at each end. The muscular contractions produced by directly faradizing the muscle are due to the excitation of the muscle, and also of the intra-muscular nerve-fibres. The most powerful muscular contractions are produced by placing one electrode on the muscle, and the other at the point where the motor nerve that supplies it is most superficial.

*Differential Action of Positive and Negative Pole in Producing Contractions.*—Not only is there a difference in the degree in the opening and closing contractions of the faradic current, but there is also a difference in the action of the poles in producing contractions. When the interruptions are rapid, as in the majority of machines, the muscle does not have time to go through all the process of lengthening and shortening with each movement of the current to and fro, and consequently it is kept in the state of tonic contraction above described. If, now, one pole be placed on some indifferent point, while the other pole is placed over the nerve to be acted on, it will be found that the *negative* pole produces stronger contractions than the positive.

This experiment is easily made, and it is not difficult to demonstrate on one's self that this stronger action of the negative pole in producing muscular contraction is entirely independent of the direction of the current—is, in short, a polar effect. We have already seen that on sensory nerves the negative pole is more powerfully felt than the positive.

*Simple Fluctuation in Strength of Current sufficient to Produce Contraction.*—In order to produce muscular contractions, it is not necessary that the current should be opened or closed. A *moderate* variation in the strength of the current—such as is obtained by adding one or more cells, or by uniting another and independent current in the circuit, or by taking off some portion of the current from the circuit—will cause muscular contractions. The contractions produced in this way are, however, less vigorous than those produced in closing and opening the circuit. It is to be observed, also, that the vigor of the contractions is proportioned to the *suddenness* of the closing or opening the circuit.

This point is frequently forced upon our observation in the treatment of paralysis. If the electrodes are armed with large sponges, and are slowly applied over the muscle, with gradually increasing pressure, scarcely any contraction, or at least only a feeble one, is produced; but if the interruption be made in the metallic part of the circuit—in the electrode by an interrupter, or in the battery—the contraction with the same current will be very energetic.

By referring to Electro-Physics (p. 55), it will be seen that the law of muscular contraction under electrization follows the laws of current-induction. Both contraction and induction occur when a *change* is made in the strength of the current by closing, opening, increasing, or diminishing.

*Muscular Contractions more Vigorous when a great length of the Nerve is Galvanized.*—The muscular contraction caused by *galvanization* is greater when a large than when a small extent of the nerve is included between the electrodes. It is not a difficult matter to demonstrate this fact. The experiment can be made on nerves of rabbits, dogs, frogs, or other animals.

*Nerves of Living Man.*—Our previous remarks have been applied to the reaction of the nerves of animals in a condition not purely physiological. When the *galvanic* current is applied to a living and healthy motor nerve in a healthy man, contraction takes place only on *closing the circuit*. This fact is constant with either pole and any direction of the current. The negative pole applied to the nerve produces stronger contraction than the positive. *At the opening of the current there is no contraction.* When the nerve is separated from the body, or injured, or fatigued in any way, the phenomena already described appear. The first symptom of fatigue is contraction both at the opening and closing of the current. When the nerve becomes more exhausted the contractions are produced on closing and opening the inverse current; and when the exhaustion is still greater, contraction is obtained only on making the direct current.

*Action of the Faradic Current.*—The faradic current, when rapidly interrupted, as in most of the faradic machines, and applied to the motor nerves, keeps up a tonic contraction of the muscle supplied by these. This contraction is maintained so long as the current runs.

If a contrivance for making *slow* inductions be connected with the faradic machine, then the contraction of the muscles corresponds to the opening and closing of the current, and *the opening contraction is stronger than the closing.*

When the current of the secondary wire is closed by placing the

electrodes on the skin, the current of the primary coil (extra current) exercises a retarding influence on the secondary current, and then the closing contraction is rendered more *gradual* and gentle from nothing to the maximum.

When the current of the secondary coil is opened, the current of the primary coil (extra-current) does not exist (see Electro-Physics, p. 55), and consequently the current of the secondary coil is not retarded and goes rapidly from its maximum to nothing.

*Differential Action of Primary and Secondary Coils.*—Duchenne has stated with a measure of truth that the current of the primary coil (extra-current) of his apparatus has a more powerful effect on the sensibility and contractility of the organs beneath the skin, while the current of the secondary coil acts more powerfully on the retina and on the skin. The primary coil is composed of thick, short wire.

The secondary coil is composed of long and thin wire with many windings.

The differential action of the primary and secondary currents on the skin, muscles, and optic nerve is due to these two causes :

1. The primary current, circulating through a short thick wire, has less tension than the secondary current that circulates through a long thin wire, because tension is developed only in the presence of resistance. Since, now, the skin offers greater resistance than the muscles, the secondary current, by virtue of its greater tension, is able to penetrate it, and also to penetrate the brain and affect the optic nerve. But the primary current, having less tension, passes through the skin, circulating in it but slightly, and goes to the muscles beneath, which are good conductors, and on these it spends its force. In other words, a current of low tension selects the best conductors, avoiding the poor conductors so far as is possible, while the current of high tension traverses also poor conductors.

2. The primary current moves in one direction, and has a mild electrolytic power, while the secondary current moves to and fro so rapidly that it cannot perform electrolysis.

*Action of the Galvanic Current.*—The interrupted galvanic current of moderate strength, if applied to a motor nerve, causes all the muscles supplied by that nerve to contract.

If the current be interrupted slowly, the contractions will be *clonic*, if rapidly interrupted, the contractions will be *tonic*. The violent contractions that occur at the moment of closing and opening the circuit of an intense current may be avoided if we begin with an extremely mild current and slowly and gradually increase its tension. By this method

Ritter was enabled to pass through his own person, without experiencing either the closing or opening shock, the enormous current generated from a battery of two hundred elements.

*Galvano-tonic Contractions.*—When very powerful currents are applied continuously to the nerves, tonic contractions are produced during the whole time that the circuit is closed. Contractions thus produced were called by Remak *galvano-tonic contractions*. They are called *galvano-tonic* contractions to distinguish them from the *clonic* contractions produced by the faradic current. When the galvanic current is applied continuously to the surface of the body, by means of moist sponges, the *galvano-tonic* contractions increase in vigor, up to a certain point, the longer the electrodes are kept in position. This phenomenon is explained mainly by the fact that the skin becomes more moist as well as hyperæmic (p. 110) by the effect of the current, and thus becomes a better conductor for the electricity. With the faradic current this increase of effect is not so observable. The current required to produce *galvano-tonic* contractions is quite powerful and painful. The strength of current required will depend on the position of the nerve acted on, the length of nerve included between the electrodes, and the individual experimented on.

*Tonic Contractions in Antagonistic Muscles.*—Remak states that when galvanic currents of great power are used, certain nervous *tonic* contractions appear in antagonistic muscles. Thus, for example, when the median nerve is subjected to the continuous action of a powerful galvanic current, contractions appear in the common extension of the same arm, so that the fingers are raised. It is probable that this phenomenon is due to *reflex action*.

*Effect of the Will in opposing and aiding Contractions produced by Electricity.*—The contractions produced by electricity can be materially aided or opposed by effort of the will of the person operated on. If a person whose muscles are being electrized concentrate his mind on the muscle that is subjected to the influence of the current, and simultaneously with the closing of the circuit, wills to contract the muscle, the contraction will be more vigorous and complete than when the electricity is not so aided. The will co-operates with the electricity, and the two agents reinforce each other, and thus accomplish more than would be possible for either alone. This can be very conveniently demonstrated on the communis extensor of the forearm. In electro-therapeutics this co-operation of the force of will and electricity becomes of great practical value. It has long been known that paralytic patients of all kinds, even those of a cerebral chronic incurable character, can be

greatly benefited by slightly *concentrating the mind on the parts to be moved, as the fingers or toes, and resolutely willing to move them.*

In practice it has been found that such treatment is of positive and permanent service.

The combination of the force of will with electricity is very much more efficacious than either when used alone. When a muscle becomes so diseased that the will is powerless to remove it, the electricity may contract it with ease. Where electricity alone causes feeble or imperfect contraction, electricity, co-operating with the will, may make the contraction vigorous and complete. In order to make experiments of this kind fully successful, it is necessary that the will and force should be concentrated *simultaneously with the closing of the circuit*; and yet experience shows that the effect of the electrization, if not too long continued, is to give tone of the muscle, so that it responds more readily to the will for several minutes, or even hours, after being subjected to the electrization. This is especially observed in muscles that are in a condition of paresis. In all these experiments much depends on the organic energy and grit of the patient. Conversely, it is found that by an effort of will the contraction of muscles induced by electricity can be within a certain limit, successfully opposed. The experiment can be made on the communis extensor of the forearm without difficulty. A feeble current will cause this muscle to contract so as to bring up the hand and fingers; by an effort of the will this can be resisted so that the hand remains on a level, or nearly so. When very strong currents are used the will is completely overborne, and has no effect whatever.

*Extent of Shortening of Muscle during a Contraction.*—In the process of contraction muscles shorten in proportion to their length. The greatest possible shortening is obtained during tetanic or continuous contraction, and not during a momentary contraction. The maximum of shortening is reached, not suddenly, but gradually, and it does not long remain at the maximum even when the electrization is continued, but begins to lengthen at first rapidly and then more slowly.

The greatest amount of shortening possible to a muscle is *three-quarters or two-thirds of its length.*

In contraction the muscle becomes a little smaller in bulk. The cause of this is not fully understood.\*

*Immediate Strengthening or Restorative Effect of Electrization on*

\* *Electro-Physiology and Electro-Therapeutics.* By C. E. Morgan, M.D. New York, 1868, p. 573.



*Voluntary Muscles.*—One very interesting effect of electrization on voluntary muscles is to increase their power of doing work. This effect, which is called by Heidenhain and Remak *restorative*, can be demonstrated in various ways. The capacity of walking, in cases of paralysis of the lower limbs, is sometimes increased at once after electrization; the patient steps across the floor easier and more firmly and rapidly, and can walk further; or he can raise his leg higher and with less difficulty. In one case of paralysis of the tibialis anticus muscle there was no response to the will until a current of medium strength had been applied, when it contracted without much difficulty. Dr. Poore\* found, on placing a weight of 17 oz. in the hand of a man holding his arm out at right angles with his body, that in four minutes the pain was so great that he could not go on; applying now a mild current through the nerves of the arm, the strength returned. Another man could hold out his arm 13½ minutes when the current was applied, but only 6 minutes without the current.

The dynamometer is a good means of studying this subject. In one case Dr. Poore found that eight successive squeezes of the dynamometer with electrization gave 477 lbs.; without electrization, 388 lbs.; a difference of 89 lbs. In another experiment made, when the hand was not tired by previous experimenting, the difference was even more marked, being a gain of 152 in six squeezes of the dynamometer.

*Effect of Fatigue of Muscles on the Contractility.*—When a striped muscle becomes very much weakened or fatigued it behaves under electrization much like the smooth muscle. Dr. Beard has demonstrated this fact on dying rabbits and dogs. Beginning the electrization just as they are cut open, the striped muscles react vigorously and normally to the current; but as the animal dies the character of the contraction changes, becoming slower and more deliberate. If, now, the current be rapidly interrupted, no contraction occurs, for there is not time for the muscle to respond. If, now, weak currents are used, the muscle contracts very much after the manner of unstriped muscle—that is, with a slow drawing rather than a rapid and vigorous action.

*Effect of Muscular Tension and Relaxation on Muscular Contraction.*—Dr. Wm. R. Fisher, of New York, has called attention to the fact that muscles contract more easily when somewhat relaxed than when in a tense condition. This experiment can be tried very easily on the common extensor of the forearm or on the peronei muscles of the leg. The fact is of practical importance in the treatment of paralysis.

Ziemssen,\* on experimenting with unpolarizable electrodes, and gradually increasing the strength by the aid of the rheostat, obtained the following results:

1. With the weakest current that caused muscular contraction there was *opening contraction at the cathode*.
2. With a current a little stronger there was *strong closing contraction at the negative pole, and weak opening contraction at the positive*.
3. With still stronger current there was also *weak contraction at the opening of the positive pole*.
4. With still stronger currents there was *a tonic contraction at the negative pole*, continuing for some time after the contraction at the closing.
5. With a much stronger current the tonic contraction was more vigorous; the other contractions are also increased in strength, and there appeared *a contraction at the opening of the negative pole*.
6. With the strongest current that can be borne, all the other contractions were increased in strength, and there appeared, besides, *moderate tonic contractions at the positive pole*.

The above results can be verified only when unpolarizable electrodes are used, for with ordinary electrodes the pain would be far too great to be endured. The opening and closing of the current must be made in the metallic part of the connection, in order to give it the greatest possible suddenness. Ziemssen suggests for these experiments the median and ulnar nerves at a point a little above the wrist. At this point the epidermis is quite thin and the nerves superficial. Judging from our observations, it is impossible to reduce this subject to a rigid mathematical law. The words "strong" and "weak," as applied to currents, are quite indefinite, and the irritability of nerves varies in different individuals at different times. It is for these reasons that observers differ in the results of their experiments.

*Electro-muscular Contractility and Electro-muscular Sensibility.*—The susceptibility of the muscle to contract under the influence of the electric current is called *electro-muscular contractility*. The sensation that accompanies this contraction of the muscles under the electric influence is called *electro-muscular sensibility*. Electro-muscular contractility and electro-muscular sensibility vary in different individuals, and in different parts of the body. They are greatly modified by disease. This fact is of great importance in diagnosis of paralytic affections.

In using the terms electro-muscular sensibility and electro-muscular contractility, we do not wish to convey the idea that they represent any

\* Op. cit., p. 80.

special nerve-functions, but rather that the general sensibility of the nerves, and the general contractile power of the muscles may be excited by the application of electricity. The question, whether there is any special sense of muscular contractility, aside from the general sensibility of the nerves, of the muscle, of the tissues that surround it, and of the bones and cartilages with which it is connected, is one that we are disposed to answer in the negative. There appear to be hysterical cases, where the consciousness of muscular contractility under the electric current remains, while the skin is almost perfectly anæsthetic; and there are certainly cases where the muscles respond to the will, but do not respond to electricity. Practically, therefore, the terms electro-muscular sensibility and contractility, especially the latter, with its subdivisions into farado- and galvano-contractility, are of great value in electro-physiology and therapeutics, and it appears to us are perfectly legitimate.

The manifestations of the electro-muscular contractility and sensibility of the muscles in the different parts of the body are modified, *first*, by the anatomical position of the muscles; *secondly*, by the quantity and distribution of the sensitive nerves; and *thirdly*, by the thickness of the skin and adipose tissue.

The muscles of the face, the *platysma* myoides and sterno-cleido-mastoid are, in health, very sensitive to the electric influence. Next in order of sensitiveness to the electric current are the anterior muscles of the forearm and of the inner side of the thigh. On the other hand, the muscles of the back possess a much less degree of electro-muscular contractility and sensibility, and the posterior muscles of the forearm, and posterior and other muscles of the thigh are much less susceptible to the electric influence than those of the anterior and inner portions of these limbs. In corpulent patients it is more difficult to affect the muscles, because adipose tissue is comparatively a poor conductor. In women and children the adipose tissue is relatively more abundant than in males and adults.

*Increase of Temperature after Muscular Contraction.*—It has been ascertained by careful experiments, that an increase of temperature results from muscular contractions produced by the electric current. Increase of temperature in the muscles of paralyzed limbs, after electrization, is frequently perceptible to the touch of the operator, and the sensations of the patient. We have repeatedly demonstrated the same results from faradization of the arms, the legs, the face, and, indeed, all parts of the body. In very many cases this increase of temperature is so marked as to be powerfully appreciated by the patient, and entirely perceptible to the hand of the operator. General faradization causes

more or less elevation of the temperature of the body. This is demonstrated by the sensations of the patient,\* and by the thermometer.

It has been shown by Brown-Séquard and Lombard that excitation of the nerves of the skin causes an increase of temperature in the limb.†

The development of heat is not aided by increasing the strength of the current above the degree necessary to produce a full contraction. It has been demonstrated that, in patients afflicted with traumatic tetanus, there is a great increase of temperature that remains for some time after death.

Investigations on the effect of muscular contraction on temperature should be made by delicate surface thermometers. Some of the superficial muscles of the forearm offer a good surface for this experiment. The thermometer must be kept firmly and uniformly pressed on the skin, and the modifying effect of currents of cold air should be guarded against. The thermometer should be kept *in situ* about fifteen minutes before beginning electrization, so as to get accurately the normal temperature. Then the nerve that supplies the muscle or muscles to be tested should be faradized.

The following investigation is from Ziemssen.‡ The patient was a strong man, who was suffering from complete paralysis of the extensor muscles of the hand and finger from nerve injury. This fact accounts for the low temperature before faradization.

Temperature on the forearm, between the extensor digit. comm. and exten. carp. radi. brev. :

The skin uncovered. . . . . 34.7° Cent.

After 4 minutes' faradization through the radial nerve :

At opening of current. . . . .	34.8
1 minute after opening the current. . . . .	35.3
5 minutes " " . . . . .	35.7
10 " " " " . . . . .	35.35
12 " " " " . . . . .	35.3

In the 13th minute faradization was renewed for 1 minute :

Temperature at opening the current. . . . .	34.7
1 minute after opening the current. . . . .	35.1
4 minutes " " . . . . .	35.45

\* *Electricité in der Medecin*, 1866, p. 29.

† *Archives de Physiologie*, November and December, 1868. ‡ *Op. cit.* p. 90.

In the 6th minute faradization was renewed for 1 minute :

Temperature at opening the current.....	35.1
1 minute after opening the current.....	35.3
5 minutes " " .....	35.6

The general results of all the investigations that have been made in this department by Becquerel, Breschet, Helmholtz, Ziemssen, Althaus, and ourselves are these :

1. When muscles are made to contract under faradization of the nerves that supply them their temperature rises.
2. This elevation of temperature is not necessarily accompanied by any increase in size of the vessels, although faradization usually increases the size and appearance of the vessels more or less.
3. The more vigorous the contraction and the longer it is continued, the higher the temperature rises.
4. If the faradization be continued long enough the temperature will be so much increased that it can be detected without difficulty by the hand, and by the sensations of the person operated on.
5. When all the superficial muscles of the body are faradized, as in the method of general faradization, the temperature not only of individual muscles, here and there, but also of the whole body, rises. This fact we have repeated and demonstrated by observations made on many varieties of temperament.

A more accurate method of investigating this subject is by means of the thermo-electric pile (see *Electro-Physics*, p.63). This instrument is capable of measuring a small variation in temperature, and also indicates the variations much more quickly than the thermometer. The thermo-electric pile is connected with a reflecting galvanometer (see *Electro-Physics*, p. 41). Ziemssen gives the following observation made on the extensors of the forearm :

TIME OF FARADIZATION.		.....	DEFLECTION OF THE NEEDLE
<i>Minutes.</i>	<i>Seconds.</i>		OF THE GALVANOMETER.
0	15	.....	- 1.5
0	30	.....	+ 2.3
0	45	.....	+ 5.0
1	—	.....	- 7.2
2	—	.....	+19.0
3	—	.....	+30.1
4	—	.....	+40.2

It will be observed that with the increase in the time of the faradization there is greater and greater deflection of the needle, just as there is a rise of the mercury in the ordinary thermometer.

*Source of Heat in Muscular Contraction.*—According to Hermann,\* who has specially studied the chemistry of the development of heat during muscular contraction, muscular work is the result of the decomposition of nitrogenous substances. Among the products of this decomposition are a fixed acid, carbonic acid, and myosine. Of these the carbonic acid leaves the body, while the fixed acid and the myosine remain and are worked over again in the organism. The muscles grow at the same time that they work and develop heat, and urea and creatine are found in the residuum. The muscle is restored by the action of oxygen, an albuminoid, and a non-nitrogenous substance in the blood.

All these complex chemical changes that are excited during muscular contraction give rise to heat. If the muscle is prevented, by mechanical means, from contracting, the heat develops in it more rapidly than when it is free. This follows from the recognized law of the correlation and conservation of forces. The force that does not appear as work appears as heat.

*Duration of Electro-muscular Contractility after Death.*—The muscles retain their contractility under electricity several hours after death. The length of time that the electro-muscular contractility is preserved varies with different muscles, with different animals, and probably, also, with the mode of death. In order to determine this question, Dr. Beard has made experiments on dogs and rabbits. Dr. Onimus,† of Paris, has experimented on the body of a murderer who had been guillotined. He found that the muscles of the tongue and diaphragm were the first to lose their electro-muscular contractility. Next came the muscles of the face, among which the masseter retains its excitability the longest. *Two and a half hours* after death the electro-muscular contractility was lost in all these muscles.

In the limbs the extensor muscles first lose their electro-muscular contractility, and in about an hour the flexors followed. The muscles of the trunk responded *five or six hours* after death, and the abdominal muscles longer still.

Onimus observed on the criminal what Dr. Beard has observed on dogs and rabbits, that when the muscle is dying it contracts most noticeably at the point where the electrodes are placed, and very slowly at a distance from the electrodes; and that the muscles respond to direct electrization with needles after they have ceased to respond to the current when applied through the skin.

\* Morgan, op. cit., p. 582 et seq.

† *Le Mouvement Médicale*, Feb., 1873.

Previously, in January and February, 1802, Aldini, a nephew of Galvani, obtained permission from the government to experiment on two criminals who were executed at Boulogne. Immediately after death the bodies were submitted to powerful galvanic excitation. The muscles of the face contracted vigorously in such grimaces as to frighten the assistants. The limbs were violently convulsed, and the bodies acted as though they would rise again to life.

At Glasgow, Ure made similar experiments on the body of a criminal that had been on the gallows one hour. The applications were made to the spinal marrow, the phrenic nerves, and the intercostal muscles. According to the position of the electrodes the body was bent forcibly back, the chest rose and fell as in the act of breathing, and the various emotions of rage, terror, despair, were depicted on the countenance. One of the spectators fainted, and several were obliged to leave the room.

*Electro-physiological Anatomy.*—*Electro-physiological anatomy treats of the physiological action of muscles under the influence of the electric current applied in such a way as to produce contractions.*

The contraction observed in an individual muscle, when submitted to the influence of the electric current, closely resembles the contraction of the same muscle when under the influence of the will.

Duchenne was the first to investigate this subject systematically, and his researches have done much to modify the accepted views concerning the functions of certain muscles. Those who desire a more complete idea of his views than is given in the following brief *résumé*, we refer to his writings.\*

*Muscles of the Face—Electro-physiognomy.*—This name has been applied to the study of character and expression, through localized faradization of the muscles of the face. By means of small electrodes the current can be localized so as to produce contractions even in the smallest muscles. For these experiments a recently dead subject has this advantage over the living man, that in the case of the latter contractions produced by the current would be complicated and interfered with by involuntary movements.

According to Duchenne, who has chiefly investigated this subject, the

\* De l'Electrisation Localisée et de son Application à la Pathologie et à la Thérapeutique. Paris, 1861. Also, Mécanisme de la Physionomie Humaine, ou Analyse Electro-physiologique de l'Expression des Passions applicable à la Pratique des Arts Plastiques. Paris, 1862. This work contains photographic representations of the various appearances of the face under electrization of the different muscles. These photographs are frequently referred to by Darwin in his work on *Expression*.

*frontalis* muscle, when a little contracted, expresses pleasure ; when more contracted, astonishment or doubt ; when strongly contracted with other muscles, terror.

Contraction of the *pyramidalis nasi* expresses sadness ; of the *corrugator supercilii*, contemplation ; of the *orbicularis palpebrarum*, contempt. Contraction of these two, united with the *pyramidalis nasi*, gives a hateful, malicious expression. Contraction of the *triangularis nasi* expresses lust ; of the *zygomaticus major*, various degrees of mirth ; of the *zygomaticus minor*, melancholy ; of the *platysma myoides*, hypocritical laughter ; of the *platysma myoides*, pain. Contraction of the *platysma myoides* and *frontalis* gives an expression of terror. Contraction of the *platysma myoides* and *pyramidalis* expresses rage. United contraction of the *zygomaticus major* and *frontalis* produces an expression of agreeable surprise. Contraction of the *buccinator* indicates age, by making furrows in the cheek.

Contraction of the *levator alæ* and *labii superioris* causes an unpleasant expression, such as a child exhibits when about to cry ; contraction of the *triangularis oris* gives an expression of sadness or disgust.

Contraction of the external fibres of the *orbicularis oris* gives the lips a position of whistling or kissing ; contraction of the internal fibres of the same muscle compresses the lips against the teeth.

*Muscles of the Upper Extremity.*—The contractions resulting from electrization of the extensors of the fingers give to the hand a peculiar appearance.

The first phalanges not only become extended, but are spread apart, while the last two phalanges become flexed.

The metacarpus forms an angle with the forearm, and in this condition the hand resembles, to a certain extent, a bird's claw.

Electrization of the *extensor digiti minimi proprius* separates the little finger from its neighbor, while contraction of the *extensor indicis proprius* brings the index and middle finger together. By the method of localized electrization the adductors and abductors of the fingers, and the *interossei* and *lumbricales*, are found to act not only in drawing these members together and separating them, but also in extending the second phalanx of the thumb and the second and third of the other fingers.

The *flexor pollicis brevis* is concerned in extending the second phalanx of the thumb, as well as in flexing the first.

So long as the arm is in its natural position, the *supinator longus* has no function to perform ; it is only when the forearm is prone that its peculiar action is manifest.



In paralysis of any one of the above muscles, it is readily seen that the observation made concerning their function is correct.

For example : if the adductor longus and extensor brevis pollicis become paralyzed, the metacarpal bone of the thumb is adducted. If the extensor longus pollicis is paralyzed, the thumb is inclined towards the metacarpus, although its movements are not markedly impaired if the extensor brevis and adductor longus are strong.

Electrization of the *deltoid* not only raises the upper arm, but also very perceptibly changes the position of the scapula. The external angle of the shoulder-blade becomes depressed, the internal angle is elevated, while the distance between its posterior spinal border and the ribs is slightly increased. In paralysis of the deltoid the arm hangs by the side almost completely helpless. The muscle is composed of three distinct groups of fibres, and the degree of paralysis depends upon the number of groups or special group involved.

The pectoralis major and latissimus dorsi muscles, although situated for the most part on the trunk of the body, are especially useful in assisting in the movements of the arm.

*Muscles of the Trunk.*—When all of the fibres of the trapezius are submitted to electric excitation, the shoulder-blade becomes elevated, its posterior border approaches the median line, the shoulders are drawn backward, and the head is thrown slightly forward and toward the opposite side. Like the deltoid, the trapezius is made up of three sets of fibres.

When the superior set is electrized the head turns toward the side irritated, and the face looks toward the opposite side.

The middle set of fibres elevates the shoulder-blade, while by the action of the lower set its inner angle is depressed, and its posterior border is drawn toward the median line. In complete paralysis of the trapezius the following symptoms are manifest : The back is rendered broader, on account of the scapula removing slightly from the spinous processes ; the shoulder becomes depressed, and, on account of the absence of steady support for the arm, its movements are rendered difficult. Electrization of the rhomboideus major and minor muscles elevates the scapula and slightly turns it on its outer angle.

If the current be sufficiently intense, the lower angle of the scapula approaches nearer to the spinous processes than the inner.

If the rhomboideus muscles are paralyzed, the scapula removes itself somewhat from the walls of the thorax, the skin between the shoulder-blade and the spine appears in folds, and the lower angle of the bone is drawn forward and outward, on account of the action of the serratus

anticus major. By excitation of the serratus anticus major the scapula is drawn forward and outward, so that the space between its posterior border and the spine is doubled. The posterior border is pressed against the ribs, while the anterior border is markedly removed from them.

When the muscle is paralyzed the shoulder-blade sinks but little, so long as the arm hangs motionless by the side; but as soon as it is moved from the body the posterior border and under angle of the scapula are lifted from the thorax, while the anterior approaches it more closely. In complete paralysis of the serratus anticus the movements of the arm are much impaired.

A single external intercostal muscle may be electrized by pressing a small electrode against the lower border of one of the upper ribs, near the origin of the serratus magnus muscle.

The individual abdominal muscles are readily influenced by electric excitation.

Electrization of the rectus muscle so stretches and draws it inward that the abdominal wall becomes flat. Irritation of the external oblique expands the abdomen laterally.

If we electrize the transverse abdominal, powerful transverse contractions of the abdomen follow. When both phrenic nerves are submitted to electric excitation, powerful and frequent contractions of the diaphragm are produced. An increased amount of air rushes into the lungs, on account of the capacity of the thorax enlarging through the descent of the diaphragm, and the moving outward of the false ribs. Atrophy of the diaphragm causes, during inspiration, a depression of the epigastrium and abdominal walls, while the thorax expands as usual.

*Muscles of the Lower Extremities.*—Electric excitation reveals the fact that flexion and extension of the foot cannot be produced by the flexor or extensor muscles alone, since these muscles tend to abduct and adduct as well as flex and extend. The flexors and extensors cause direct flexion and extension only when they act in conjunction with certain other muscles.

The movements of the foot are controlled by four sets of muscles. These are :

The tibialis anticus, which at the same time flexes and adducts the foot—the flexor adductor muscle, the extensor digitorum communis longus and extensor hallucis, which flex and abduct the foot—the flexor abductor.

The gastrocnemius solius and tibialis posticus, which extend and

adduct the foot—the extensor adductor, and the peroneus longus and brevis, which extend and abduct the foot—the extensor abductor.

Electrization of the tibialis anticus, or, in other words, the flexor adductor muscle, not only extends and adducts the foot, but lifts the inner border of its upper portion as well.

Electrization of that group of muscles called the flexor abductor, besides flexing and abducting the foot, extends the four last toes, lifts the outer border of the foot, turns the sole outward, and bends the great toe.

Pes equinus may result from the stronger action of the extensors.

If the flexor abductor group become paralyzed, the movement of the foot is reversed—the sole turning inward and the anterior portion turning upward.

Electrization of the extensor adductor group so extends and *adducts* the foot that the heel is directed outward and the great toe inward. The first phalanges of the toes become extended, and the last flexed, giving to them the form of claws.

Electrization of the extensor abductor so extends and *abducts* the foot that the internal malleolus becomes decidedly prominent through the sinking of the inner border and the elevation of the outer border of the foot. Paralysis of this last-named group of muscles produces in the course of time what may be termed a flat foot. This results from the disappearance of the arching of the foot.

In consequence of paralysis of the extensor adductor the foot naturally becomes abducted, the arch of the dorsal surface is increased, and instead of the flat foot above mentioned, we have a very decided hollowing out of the plantar side.

## CHAPTER VIII.

### ACTION OF ELECTRICITY ON INVOLUNTARY MUSCLES.

CONTRACTIONS are produced in a *voluntary* muscle the instant the poles of a galvanic battery, or of an electro-magnetic machine in operation, are applied to it. The contraction of the muscle continues during the passage of the *faradic* current, but when the galvanic current is used quickly relaxes after the first shock. When, however, the intestines, the stomach, the œsophagus, and other parts which are composed of *involuntary* muscular fibre, are subjected to the electric current, movements are not induced in them *until a certain time after the tissue has been acted upon. The movements thus excited continue for a time after the cessation of the current, and do not, as in the case of voluntary muscles, at once return to their normal condition.*

*Iris.*—Faradization of the iris, with a very gentle current in a room that is moderately darkened, causes it to be constricted or dilated, according to the position of the electrodes.

*Stomach.*—Faradization or galvanization of the stomach causes gradual shortening of the transverse and longitudinal fibres in the direction from the cardiac to the pyloric orifice. Dr. Rockwell, in the treatment of paralysis of the œsophagus associated with a sort of atony of the stomach, has frequently had occasion to observe the readiness with which this phenomenon is demonstrated in the living man by applications directly to the mucous surfaces of the parts.

*Intestines.*—If finely pointed electrodes or needles, connected either with a faradic or galvanic apparatus, be applied to the intestine of a living or recently killed animal, steady and firm contraction takes place at the points where the electrodes are applied. Under a mild current the contraction is slow, steady, and gradual. The intestines are drawn up after the manner of a woman's work-bag. This contraction, though most marked just at the point where the needles touch the intestines, is also observed a little distance between and on the outer side of the needles. Under strong currents this constriction takes place very rapidly, and goes on until the calibre of the intestines

is nearly closed. When the electrodes are removed this constriction slowly disappears. These phenomena are seen both in the large and small intestines and in the rectum. The duodenum responds most readily, the rectum and colon less so. These phenomena are more or less modified by the condition of the animal, whether living or dead, and whether recently or long killed. This fact of electro-physiology, which has been frequently demonstrated on animals, is very suggestive in a practical point of view. The value of electricity in constipation is, in view of these observations, partially explained.

*Spleen.*—When the spleen of certain animals, living or recently killed, as the dog, is submitted to the action of a tolerably strong current, either faradic or galvanic, a visible drawing and contraction throughout the entire extent of the organ, not only where the electrodes are applied, but between them and beyond them, in every direction, there is manifest shrinking of the tissues, with change of color. This fact, which has been disputed by some physiologists, we have demonstrated in a variety of experiments. The phenomenon is not so noticeable in the spleen of the rabbit as in that of a dog, and in order that it may occur rapidly and be easily seen, the current used must be of considerable strength. The shortening and discoloration of the spleen under electrization appears to be more or less permanent. This physiological fact suggests the query, whether the enlarged spleen of intermittent fever might not be treated by electricity.

*Bladder.*—When the filled or emptied bladder of a living or recently killed animal is acted on by either current, of moderate strength, a visible drawing and contraction take place in various directions. The tissue becomes firmer and harder, the cavity diminishes, and if it contains urine a portion of it is expelled. This electro-physiological fact is utilized in cases of paresis and paralysis of the bladder.

*Uterus.*—The uterus of animals and of the human being contracts after the manner of the intestines, bladder, and other involuntary muscles. Whatever pole is used, or in whatever direction the current be applied, contraction takes place whenever the current is applied, whether the uterus is or is not in a gravid condition. Both faradization and galvanization have this slow contracting influence on the uterus.

In the chapter on Diseases of Women, the very interesting and important practical applications of this physiological fact will be pointed out in detail. It applies especially to the electrical treatment of metritis and uterine engorgements.

*Ureters.*—The ureters are constricted and shortened by electrization, and as in the case of the uterus, the intestines, and the spleen, the con-

tractions take place, according to the law of their physiological action, from the kidneys toward the bladder, and the contractions continue after the electrodes are removed.

*Vas Deferens, Epididymus, and Tunica Vaginalis.*—When the electric current is applied to the vas deferens, the epididymus, or the scrotum, they likewise contract after the manner of the intestines, uterus, and so forth. The scrotum contracts rapidly, almost instantaneously, under a strong current, and remains contracted for some time, as we have demonstrated on rabbits and dogs, and on the living human being.

*Gall-bladder.*—When a current of considerable strength is applied to the gall-bladder by pointed electrodes, constriction takes place at the points of application, and the whole bladder tends to contract, and, like the urinary bladder, to discharge its contents. It is not impossible that a powerful current sent through the liver of the living subject, by external applications, may cause contraction of the gall-bladder; and in this way we may in part explain the value of electrical treatment in jaundice.

*Æsophagus.*—In rodents the œsophagus consists of striped muscle only; in birds it consists of unstriped muscle, and in man of a combination of both striped and unstriped muscle. Both sets of fibres, longitudinal and circular, contract under the current, not only at the points where the electrodes are applied, but through the whole length downward toward the stomach. In the treatment of dysphagia this fact may well be considered.

*Heart.*—The effect of electrization of the pneumogastric and other nerves that supply the heart has already been considered. The effect of direct electrization of the tissue of the heart itself is not without interest. Galvanization, with currents of moderate strength, of the heart of an animal that has stopped beating, may cause a return of its rhythmical action. It has been sometimes observed that the contractions return more vigorously in the right than in the left side. According to our observation, in the hearts of dogs and rabbits much depends on the strength of the current used. If a strong current were directed through pointed electrodes to the substance of a heart of a dying animal, the pulsations are in part arrested, but they recur as soon as this current is broken. These conclusions are based on a large number of observations. When the heart has fully stopped it may be restored by a weak current, and again arrested by a strong current.

*Blood-vessels.*—The small arteries that contain considerable unstriped muscle contract under the current, after the manner of the intestines; that is, the contraction does not appear instantaneously, but a little

time after the needles are applied it goes on slowly, and after the needles are removed they gradually return to their normal condition. In the larger arteries this contraction is not so marked.

It will be observed that electricity acts on unstriped muscular fibre, in this respect at least, very much like ergot. The power of ergot to constrict the blood-vessels is the explanation of its great value as a remedy in spinal and cerebral congestion. The efficacy of electrization in the same affections, as well as in sprains and various local inflammations, may be in part explained by the same theory. This subject will be discussed in the chapters devoted to the Influence of Electricity on Nutrition and Spinal Congestion.

The above conclusions are based largely on our own experiments, although many of the observations had been previously made by various physiologists.

There were, however, certain queries in regard to the differential action of the poles, and of the two currents, and of weak and strong, on involuntary muscle, that had not been answered. These queries have aimed to solve by a large number of experiments on animals. The records of one set of these experiments, noted at the time by our friend Dr. John Van Bibber, of Baltimore, are herewith presented. It will be observed that the chemical and other effects of the current, besides the contracting influence, are noted.

*Experiment 1.*—The abdominal cavity of a good-sized rabbit was opened, and a medium faradic current, with needle electrodes, was applied to the upper part of the small intestines. Contraction produced most vigorous at the positive. A vermicular motion was also observed not only in the part within the circuit, but extending some distance beyond each pole. The rabbit was fully under ether, and the only other muscular movements were cardiac and respiratory. The color of intestines was normal and healthy, and was undisturbed during this operation.

*Experiment 2.*—A galvanic current, sixteen cells, was now applied, with needle electrodes, a little below point of first experiment. There was an immediate change in the circulation of the part. It became darker and venous in its appearance, presenting the appearance of a clot. The intestines, before so flaccid as to render the insertion of a needle difficult, became very full and hard. The negative pole was loose in the tissues, with bubbles of hydrogen generated around it, and, on the other hand, the positive pole became very firm in its insertion, with evident constriction of muscular fibre around it.

The first effect, therefore, seemed to be congestion, and afterward coagulation.

*Experiment 3.*—On stomach, with galvanic current, sixteen cells. In region of positive pole the circular fibres are much contracted, and the same disintegrating effects of negative pole were observed.

*Experiment 4.*—Faradic current on large intestine. Contraction of muscular fibres was observed, and thought to be greater at positive pole.

*Experiment 5.*—Faradic current on spleen. The smooth surface of that organ was soon corrugated, tending to show that the tissues were contracting under its influence.

*Experiment 6.*—Galvanic current on spleen. Generation of hydrogen at negative pole, also congested appearance, and after removing needle very dark spot at negative pole.

*Experiment 7.*—Faradic current on bladder. The bladder was partially filled with urine, and when the current was applied there was great and immediate contraction of muscular fibres and expulsion of urine.

*Experiment 8.*—On left kidney, faradic current. Muscle contracted, and seemed to be permanently so, at least during observation.

Right kidney, galvanic current. Same effect at negative pole, dark congested spot; but during passage of current the bladder, which had been much contracted by faradic current, seemed to fill up.

*Experiment 9.*—On liver. No action. The rabbit seemed to show remarkable vitality, and it was necessary to renew ether very frequently. It was determined then that the electricity seemed to prolong life, even after it had been so taxed by anatomical mutilation.

The conclusions from a large variety of experiments, of which the above is a fair illustration, are these:

1. Both currents—faradic and galvanic—cause an unstriped muscle to contract in accordance with the law of its physiological action. It remains contracted, and after the breaking of the current gradually returns to its normal condition.

2. The time when the contraction begins, and the vigor with which it continues, and the rapidity with which it returns to its normal condition, after the breaking of the current, varies with the organ acted on, with the strength of the current, and with the condition of the animal acted on, whether living, dying, recently or long dead.

3. The *positive* pole has a more powerful contracting influence on unstriped muscles than the negative. The differential action of the poles is seen in both currents, but is more decided with the galvanic. This fact we were, we believe, the first to discover. This fact of the more potent action of the positive pole on unstriped muscle is of con-



siderable signification in the treatment of engorgements of the uterus etc. It will be discussed in the chapter on Diseases of Women.

4. Unstriped muscles can also be made to contract by faradization or galvanization of the nerves and nerve-plexuses that supply them—indirect electrization.

5. The behavior of the different organs that are supplied with unstriped muscles under electrization depends on the relative amount of muscle in their tissues. The intestines, the scrotum, contract rapidly and vigorously; the spleen and arteries less perceptibly and more slowly.

The liver and lungs do not apparently contract under either current. The electrolytic action of the current is observed in these organs, as in all other tissues.

6. The differential reaction of voluntary and involuntary muscle to the current is mainly a matter of *degree*. Both kinds of muscle contract in accordance with the law of their physiological action, under both currents, and both return to their normal condition; but involuntary muscle returns very slowly, while voluntary muscle returns rapidly, almost instantaneously. When voluntary muscles have become greatly exhausted through fatigue or death, they behave very much like involuntary muscles.

## CHAPTER IX.

### ACTION OF ELECTRICITY ON THE BLOOD.

THE action of the galvanic current on the blood is a subject to which we have given at different times considerable attention. Blood coagulates so quickly after leaving the living body, that the action of electricity upon it can only be studied with satisfaction when the electrodes are placed within an artery or vein, or in a current of blood as it flows from the wounded blood-vessels before the process of coagulation has set in. We have experimented on blood with the galvanic current in both ways.

When the needles connected with the poles of a galvanic battery are inserted into the feebly flowing blood of a wounded animal, electrolysis at once takes place with differential polar action of a striking character. At the positive pole a small, firm, and dark clot forms, that adheres closely to the needle, especially if it be steel that is readily oxidized. At the negative pole a larger, softer, lighter, yellowish clot forms, with a mixture of foam or froth from the bubbles of hydrogen.

If the current be strong, and the operation protracted, the positive steel needle will become either destroyed by oxidization or greatly reduced in size.

From the above it will be seen that the action of electricity on the blood is mainly, if not entirely, of a *chemical* character—in a word, *electrolysis*, or electro-chemical decomposition. Golubew and Burdon-Sanderson have studied the effect of faradization on the blood-corpuscles under the microscope, and Rollet and Neuman have studied the same under the influence of the galvanic current. It has been shown that the red corpuscles of the blood are discolored by the alkalis of the negative pole, and caused to shrink by the acids at the positive pole. Under the discharges of the Leyden jar the red corpuscles change their shape and lose their color.

March 12th and 24th, 1871, Dr. Beard made, with Dr. E. L. Keyes, a number of experiments on dogs, in order to determine the differential action of the poles in producing a clot. One method of ex

perimenting was to etherize the animal, open the abdomen through the linea alba, and expose the aorta, into which needles, insulated with hard rubber up near to their points, and connected with both poles, were introduced. In some cases the artery was constricted, in others not. We condense the record of the experiments from the published statements of Dr. Keyes,\* based mainly on notes made at the time by the physicians who co-operated with us.

EXPERIMENT I.—*March 17th.* A small dog was etherized, the abdomen laid open through the linea alba, and the aorta exposed. Positive and negative needles, insulated (imperfectly) with hard rubber, were introduced into the aorta about one inch apart. Both needles were of steel, gold plated at the points. The negative needle was accidentally run through the artery, and emerged into the muscle beneath. The current from sixteen cells of a Stöhrer's battery was passed for ten minutes. The artery was not compressed. Blood flowed through it at great force.

*Result.*—Bloody foam surrounded the negative needle, the blood emerging from the artery. Needle loose. It dropped out, the blood followed.

Positive needle adherent to artery, requiring a little force to pull it away. Artery was cut, before the needle was removed, to look for clot. No clot discovered in the vessel. A little black material was found adherent to the wall of the artery, and to the positive needle at the point of entrance. The lining membrane of the artery was altered and discolored, wherever either needle had touched it, over a space about one and a half line in diameter.

EXPERIMENT IV.—Medium-sized dog etherized. Positive needle (platinum), insulated with hard rubber, was placed in the artery. Negative needle (platinum), insulated with shellac, in muscles near the spine. Eighteen cells Stöhrer. Time, ten minutes. Current of blood about three-fourths, arrested through the artery, by compression with thumb and fingers, one inch above and below the needle.

*Result.*—Firm black clot outside of the vessel at point of the entrance of needle, and where the opposite wall was touched by the needle's point. Inside—firm, black clot, adherent to the wall, but not large enough to obliterate the vessel.

Lining membrane of artery blue-black, and coats of vessel adherent and condensed at point of entrance of needles, and where opposite wall had been touched. Needle not much acted upon. A little flake of

\* Practical Electro-Therapeutics, *New York Medical Journal*, December, 1871.

hard rubber came off, and was left attached to the clot. A few bubbles of oxygen escaped from the vessel alongside the needle.

EXPERIMENT VII.—Positive needle gold, non-insulated. Negative needle steel, non-insulated. Both in vessel. Sixteen cells. Time ten minutes.

*Result.*—Clot same at the positive pole as in Experiment IV., but action on lining membrane was much less than in that experiment. Gas escaped at negative needle. No clot at negative needle. Artery compressed only below, circulation arrested.

EXPERIMENT XI.—Renal artery of dog was cut, and blood allowed to flow into peritoneal cavity. As it flowed, negative and positive steel, non-insulated needles, connected with eighteen cells, were dipped into it. Action commenced at once. A dark clot formed about positive needle, and a light foam around negative. At the end of one minute, at the positive needle, a black clot had formed, a quarter of an inch in diameter, dense enough to be lifted out of the fluid on the point of the needle, and to sustain its own weight. At negative needle there was a spumous yellow mass, which could be lifted in part from the blood on the needle's point, but which had no consistence whatever.

The experiments were continued with Dr. Keyes, at the slaughter-house, the needles being placed in the warm blood, as it flowed from the arteries of dying animals. These experiments were performed under great difficulties, and at some risk of being kicked by the expiring bullocks, and did not therefore lead to any important results.

Blood coagulates so quickly after it leaves the body that when we wish to determine the chemical action of the electric current on it, it is necessary to introduce the needles into the vessels of the living animal, or into the blood, just as it is flowing from the vessels.

During the winter of 1873 Dr. Beard made, with the assistance of Dr. J. H. Raymond, similar experiments on dogs and rabbits. The animals were etherized, cut open, and the needles (platinum) inserted into different arteries and veins. In some cases also the arteries were ruptured, and the needles were introduced into the pool of blood before it had time to coagulate.

The conclusions in regard to the electro-coagulability of the blood, to which we have been led by these repeated experiments on animals and on men are these :

1. Both poles of the galvanic current cause a clot in blood, either running in an artery or vein, or freshly drawn, and stationary.
2. The positive clot is black, hard, and small ; the negative clot is light, soft, and bulky.

3. These clots are the result of the electrolytic action of the current, with the evolution of oxygen and hydrogen, of acids and alkalies, and their subsequent combinations.

4. The largest clot and most satisfactory observation in an artery is caused when both *poles* are placed within the blood-vessel and near together. The reason of this is, that when the poles are near together in the blood, the resistance is very much less than when one of the poles is on the surface.

5. In order to produce a firm clot of sufficient size to obstruct a large artery, strong currents—from 20 to 40 cells—are required, and quite protracted séances. The process of coagulation under the current is comparatively a slow one.

6. Electro-coagulation in a blood-vessel is aided by any compression that impedes the rapidity of the flow of the blood. The slower the current runs, the more rapid and firm the coagulation. Small and recent clots, especially those connected with the negative pole, may possibly be washed off. The practical bearings of these conclusions on the electrical treatment of aneurisms will appear in the section on Electro-Surgery.

## CHAPTER X.

### ELECTRO-CONDUCTIVITY OF THE HUMAN BODY.

THE chief constituent in the human body is water, which is about three-fourths of its average weight.\* The saline constituents which the water holds in solution vary in quantity and quality in the different tissues and the different parts and organs of the body.

The conductivity of the body, as a whole, may be best understood by regarding it as a mass of water and saline ingredients, with solid tissue interspersed. The degree of resistance to the current that different parts of the body offer will therefore depend on their structure. Those parts which, like the bones and epidermis, contain little water, will offer a much greater resistance, and be poorer conductors, than those parts which, like the muscles, nerves and tendons, and cartilages, contain a large percentage of water. Soft parts, like the stomach, intestines, and mucous membranes in general, offer comparatively little resistance, because they contain so large a percentage of saline solutions. Saline solutions conduct better than simple water, and warm saline solutions conduct better than those which are cold.

The human body, as a whole, conducts electricity *fifteen to twenty* times better than pure cold water, provided the skin is thoroughly moistened. It owes this superior conductivity to the *warm saline* solutions which it contains. According to recent experiments by Richardson, the blood is the best conducting material of the body.

*Percentage of Water in the Tissues.*—To ascertain the relative proportion of water in the different tissues of the body is a subject that has occupied a number of observers. The results of the different investigations do not agree mathematically, for the reason, partly, that individuals differ in the water-holding capacity of their tissues, as in all other respects.

The following table † gives at a glance the results of the different investigators :

\* Pereira, *Food and Diet*, Am. ed., p. 39.

† Ziemssen, *Die Electricität in der Medicin*, vierte ganz umgearbeitete Auflage. Erste Hälfte, p. 18. 1872.

## PERCENTAGE OF WATER IN THE TISSUES OF THE HUMAN BODY.

	Adults.	New-born children.
Blood.....	80.5 (E. Bischoff)	85.0 (Bischoff)
Gray matter of the brain.....	85.0 (Lassaig)	88.6 (Bischoff)
White " " " " .....	73.0 (Lassaig)	
Gray matter of spinal cord.....	71.0 (L' Hérít)	81.8 (Bischoff)
White " " " " .....	65.0 (Von Bibra)	
Nerve matter.....	77.0 (Ranke)	64.5 (Von Bibra)
Muscle .....	39.68..... (Von Bibra)	87.8 (Bischoff)
Liver .....	81.2-84.8 (Ranke)	82.5 (Oidmann)
Elastic tissue .....	76.1 (Von Bibra)	
Fatty " .....	70.4 (Schultze)	
Connective tissue { cornea .....	80.9 (Ranke)	
{ skin.....	75.8 (His)	
{ <i>lederhaut</i> .....	57.5 79.1..... (Wienholt) (Ranke)	
Bones—os parietal .....	14-16..... (Friedleben)	18-29 (Friedleben)

An examination of the above table shows clearly these two facts :

1. The percentage of water in the different tissues of the human body, excepting the skin and bones, is almost uniform—ranging between 70 and 90. The percentage of water in the skin is almost two-thirds as great as in the brain, spinal cord, and nerves. In the bones the percentage of water is *one-fifth* that of the soft tissues.

2. There appears to be more water in the tissues of new-born children than in adults. The difference, however, is but trifling.

Investigations of a similar character have been made on the tissues of oxen, dogs, frogs, cats, hares, and rabbits ; the results do not differ materially from those obtained on the tissues of human beings.

Compared with a number of metallic substances, the human body is an exceedingly poor conductor. Thus it has been estimated that copper is several thousand million times a better conductor than the human body.

Dr. C. B. Radcliffe made three experiments, in which he measured the resistance of nerve, tendon, and muscle, as nearly of the same shape and size as possible. The pieces were taken from the sciatic nerve, the tendo-Achillis, and the adductor longus of a recently killed rabbit. He found the mean resistance of one inch of the sciatic nerve to be

40,000 units (see p. 66)—that is, about eight times the resistance of the Atlantic cable; of the tendon, 38,000 units; and of the muscle, 12,000 units.\*

*Bones and Skin poor Conductors.*—It should never be forgotten that the epidermis, in a *dry* state, is a poor conductor. In practice this resistance of the epidermis is overcome by thoroughly moistening it. The hair and nails are also poor conductors. In making applications to the top of the head it is necessary to thoroughly moisten the hair. The bones contain less water than the soft parts, and are consequently poorer conductors. Soft parts which are thus enclosed in a bony covering are less powerfully affected than soft parts which are not so enclosed.

*The Current tends to take the shortest Way between the Electrodes.*—The electric current always takes the shortest and most direct course from one pole to the other, provided the media intervening between the electrodes is of a uniform conductivity. When, therefore, the positive electrode is applied to one part of the body, and the negative to the other, the current would diffuse itself uniformly between the poles, provided the structures of the body between them were uniform. But, as has been seen, the different parts of the body vary widely in regard to their conductivity,—those which contain a large quantity of saline solutions being good conductors, and, *vice versa*, those which contain a small quantity being poor conductors,—the difference of conductivity between muscle and bone being nearly twenty to one.

The current does not affect all parts alike. The extent to which any part is directly reached, when the current is applied over the surface, will depend both on its structure and its situation.

Soft parts, which contain a large amount of water, like the brain, spinal cord, and abdominal viscera, are good conductors, and unless their situation is unfavorable, they are directly and powerfully affected by the current, when applied to the surface by means of moist conductors. On the other hand, bone, which contains a much less percentage of water than the muscles and soft parts, is comparatively a poor conductor. Accordingly, soft parts which are partially or entirely enclosed by bone are much less readily affected by external applications than would be the case if they were exposed.

Another legitimate inference from the accepted theories of the nature of electricity, and from what we know of the relative conductivity of the different tissues of the body is, that when electrodes are placed on the surface of the body the current moves between them in a kind of

\* *Dynamics of Nerve and Muscle*, p. 19.



undulative or wave-like manner, extending on both sides of the median line between them for a considerable distance.

That these theories, in regard to the electro-conductivity of the body, are sound, is proved in three ways :

1. By experiment on the living subject.
2. By direct experiment with the galvanoscopic frog and reflecting galvanometer on the dead subject.
3. By the evidence of pathological cases.

That the tendency of electricity is to take the shortest road between the electrodes, is proved by the following experiment: The two forearms are crossed so that they touch each other a little distance above the wrist. Placing now one electrode on the outer surface of each arm, and letting the galvanic current run, a feeling of heat and pricking is felt, not only beneath the electrodes, but also, to a less degree, at the *polar surfaces of the forearms where they touch each other*. On removing the electrodes it is observed that not only the spots beneath the electrodes, but also the spots where the arms touched, have become reddened.

This shows that a portion of the current takes the shortest way from one electrode to the other, although that road lies through two layers of epidermis, which is a very bad conductor.

A portion of the current, in this experiment, goes up the arm, across the body, and down the other arm.

In order to ascertain what proportion of the current took the route across the arms, Ziemssen\* made the following experiment: Putting one forearm over the other, as in Erb's experiment, he placed between them two plates of zinc, connected with a delicate reflecting galvanometer (see Electro-Physics, page 41). The result of the experiment, when 20 elements were directed across the arms, was a deflection of the needle  $36.3^{\circ}$ . The same arrangement made on the dead body gave, with 10 elements, a deflection of  $8.5^{\circ}$ ; with 15 elements, a deflection of  $19.7^{\circ}$ ; with 20 elements,  $28.2^{\circ}$ . On separating the forearm, so that the whole current must run around through the arms and body, he found that with 10 elements there was a deflection of  $15.9^{\circ}$ ; with 15 elements, a deflection of  $31.7^{\circ}$ ; with 20 elements, a deflection of  $48.5^{\circ}$ . The conclusion was that in each experiment *one-half* of the current went across through the forearms, and the other half up and down the arms and through the body.

*Evidence of Pathological Cases.*—When the spinal cord is in a condi-

\* Op. cit., p. 22.

tion of health, a powerful current may be applied down the back without discomfort; but in cases of myelitis, spinal congestion, and other morbid states, very marked and peculiar symptoms are sometimes observed. We have seen a case of myelitis when even a very mild faradic current over the spine, near the supposed seat of the disease, caused severe pain in the right leg that continued for several hours. Such a phenomenon is never observed in health. The fact that it does occur, especially when the electrodes are not placed near any prominent nerves, shows very clearly that the current affects the spinal cord in a more direct way than by mere reflex action.

The sensations of the patient, and the results of treatment, also show that the stomach, liver, spleen, intestines, and the genital organs in both sexes, are traversed by the current in external applications of either current.

*Experiments on Dead Subject with a Frog Preparation.*—Erb opened the skull of a dead body, took out the brain, and covered the outside of the skull with pieces of muscle about three-quarters of an inch thick. Over the muscle pieces of skin were placed, and over the skin the electrodes. The skull was then filled with the brain, in such a way as to avoid any direct connection with the muscle. The skull was thoroughly dried, and a prepared frog placed on the cerebral matter. A very gentle current was then let on, and both on opening and closing the frog contracted energetically, showing that a portion of the electricity at least passed through the brain. Branch currents may also have gone around through the layer of muscular tissue; but the important point, that some of the electricity took the short way direct through the skull and brain, was in this experiment conclusively shown.

The same experiment with the faradic current showed the same result.

Similar experiments on the spinal cord showed that the current penetrated the vertebræ as readily as through the skull.

*Actual Experiment with a Reflecting Galvanometer.*—The evidences already given are sufficient, with corroboration, to establish the fact, that the electricity, when applied to the surface of the body, goes through the tissues lying between the electrodes, and that all the internal organs may be thus acted on by the current. The mathematical demonstrations of this fact that have been recently made by Burchardt, and after him by Ziemssen, are, however, none the less interesting. Ziemssen's method of investigation was to insert two platinum needles, insulated to their points, into the organ to be experimented on, as the brain, spinal cord, sympathetic, lungs, liver, etc., and connect them with

a delicate Wiedmann's reflecting galvanometer, while the electrodes of a galvanic battery of from 1 to 50 elements were applied *externally*, in such a way that the current, in passing from one to the other, must pass through the place where the points of the needles were inserted. These experiments were performed on the dead subject, and on animals, living and dead. Unpolarizable needles (Electro-Physics, p. 31) were used. The body, or part to be examined, was isolated on wood or glass. By these means he easily demonstrated these two facts :

1. *That all the internal parts and organs of the body can be traversed by derived currents (see page 29) when the electrodes connected with a galvanic battery are properly placed on the skin.*

When the electrodes are placed on the head, derived currents pass through the brain. When the electrodes are placed on the spine, derived currents pass through the cord. In the same way it was demonstrated that the sympathetic, heart, lungs, liver, spleen, intestines, and bladder were traversed by derived currents when the electrodes were applied respectively to the neck, thorax, and abdomen. Similarly also the nerve-plexuses and great veins were shown to be traversed by currents when external applications were made.

2. *The derived currents were usually most powerful, that is, the greatest quantity of electricity passed in a direct line, between the electrodes.*

When the ends of the unpolarizable needles were removed from one another, near the central line, the needles showed less and less deflection, proving that the derived currents were weaker. To this general law there are, however, exceptions. The current which contains a very large percentage of water conducts electricity better than other neighboring parts, even when out of the axis of the curve.

3. *The derived currents can be sent through the internal parts in any direction, and increase in strength with increase in the strength of the principal current.*

When the principal current is reversed, the derived currents will be reversed also. In one experiment, on the dead body of a young man, the electrodes of the principal current were placed behind the ears. Two holes were made in the parietal bones, in the track between the electrodes, and two other holes were made, about six centimetres farther forward, and about eight centimetres from each other. In the holes made through the bones into the brain were placed the unpolarizable needles connected with the reflecting galvanometer. Two needles were also in the tubercula quadrigemina. The results of the observations are contained in the following table :

No. of elements.	Needles in posterior poles in direct line of current.	Needles in anterior poles out of direct line.	Needles in tubercula quadrigemina.
5	1.5°	0.6°	1.6°
10	2.1°	1.7°	2.2°
15	2.9°	2.8°	3.5°
20	6.5°	3.2°	4.2°

In the above observation, which may be regarded as a crucial and convincing one, these three points are distinctly proved :

*First*, That the current passes from one electrode to the other through bone and brain.

*Second*, That most of the derived currents take the direct route in the axis between the electrodes, and that the strength of the derived currents, the conductivity of the parts being the same, diminishes in proportion to their distances from the axis.

*Third*, That the tubercula quadrigemina, by virtue of their fluid structure, conduct electricity better than the after parts of the brain.

*Fourth*, That the strength of the currents sent through the body is proportioned with considerable exactness to the strength of the current employed in the application.

The laws of conductivity of the body, as here demonstrated in the brain, have also been similarly demonstrated in the spinal cord and in all the organs of the thorax and abdomen.

The grand conclusion from all these experiments, and from clinical experience, is that *the electro-conductivity of the human body is to be explained, mainly, by the ordinary physical laws of electro-conduction, and only to a very limited extent by physiology.*

*Physiology and pathology* may come in to modify, to a slight extent, the conductivity of the body; for, as we have seen, individuals differ in their conductivity. Increase in the quantity of blood or salts in the body increases the conductivity, and diminution of blood or of the salts, as takes place in some diseases, diminishes the conductivity. But all these varying factors have caused only a very slight perturbation of the physical laws of electro-conductivity.

There is some difference in the conductivity of the living and dead body, but this difference can mostly be explained by *physical* principles. It may well be questioned whether the principle of life, whatever that may be, exerts any very important influence on electro-conductivity. Burchardt found that when more saline solutions were injected into the dead body the electro-conductivity was increased. This is just what

we should expect on physical principles, because warm saline solutions are good conductors of electricity in the body or out of it.

According to Ranke, living muscle conducts much worse than dead muscle, the proportion being as 100 to 56. Living muscle conducts 115,000,000 times, and dead muscle 64,400,000 times worse than copper. Dead muscle conducts better than living, on account of the decomposition and chemical changes that take place after death, and especially on account of the accumulation of lactic acid.

*Electro-conductivity modified by Age and Temperament.*—Young people offer greater resistance than old people, for the probable reason that the tissues of the old contain more of the salts than those of the young. The hands of those who labor with muscle, and whose epidermis is thereby thickened, offer greater resistance than the hands of those who live by brain alone. The right hand, being more used than the left, has a thicker epidermis, and therefore presents a greater resistance.

Different individuals of the same age and condition differ in their conductivity in a manner that cannot be fully explained. When "shocks" of a battery, or faradic machine, or Leyden jar are sent through a number of persons in a row, some will feel it slightly, others strongly, and perhaps one or more may be almost if not quite prostrated. This fact may explain some of the freaks of lightning, for it has long been known that when a number of persons are standing near together some may be struck down and others unharmed. Some Indians and negroes, it is said, can take hold of the electric eel without receiving shocks.

The same individual may conduct differently at different times. As the body is perpetually changing, as it varies in its intimate constitution, not only from year to year, but from day to day, and from moment to moment, it is easy to understand why it should vary in its susceptibility to electricity, just as it varies in its susceptibility to the articles of ordinary food, to stimulants and narcotics, and to internal medication.

## CHAPTER XI.

### THE EFFECT OF ELECTRICITY ON NUTRITION.

It is not a little surprising that electricity should have been used as a therapeutic agent for more than a century before it began to be recognized among scientific men as a powerful means of aiding nutrition. In 1867, after a series of preliminary experiments, mainly conducted by Dr. Rockwell, we ascertained that electrization was a *tonic* of most remarkable efficacy; that its permanent tonic effects were, indeed, far more wonderful, as well as more valuable, than its primary stimulating effects. When we announced this discovery to the profession, in our Treatise on the Medical Use of Electricity, the statement was received by many, and especially by those accustomed to and familiar with other electro-physiological and electro-therapeutical researches, with incredulity and surprise.

The attention of observers has been so exclusively directed to the primary stimulating effects of electricity, that they have neglected to pursue the subject further, and to study its permanent effects on nutrition.

The effects of the passage of electricity through the body are of a fourfold character :

1. *Mechanical.*
2. *Physical.*
3. *Chemical.*
4. *Physiological.*

Inasmuch as the effect of electricity on nutrition is a resultant of all these four orders of effects, it is necessary to speak of each in some detail.

The *mechanical*, *physical*, and *chemical* effects of electricity on the body are similar in character to the same effects of electricity on any substance whatever; the *physiological* effects are those which take place in virtue of the *vital* properties of the tissues. The *mechanical* effects of electricity on the body are most markedly appreciated under the faradic current. The reason is clear from the nature of the faradic current. It is a current of alternation, of to-and-fro motion, of constant closing and breaking (see Electro-Physics, p. 54). When it

passes through the body, even when it produces no muscular contraction, it acts very much in the same way as gentle tapping, or pounding, or rubbing on the tissues; and this gives passive exercises to all the deeper lying as well as the superficial tissues. We may believe that the molecules of the tissues are agitated by the passage of the current, as the particles of a bar of iron are moved by the influence of magnetization (see p. 9), or as bodies are expanded by heat. The numerous branch currents going to and fro act as so many shuttlecocks, keeping every atom in incessant disturbance. That the simple process of tapping on the surface of the body, by means of the *vibrations* that it excites, has a positively beneficial effect in certain chronic affections, has long been recognized. It is reasonable to suppose that this beneficial effect is in part due to the increase of endosmotic action.

*Physical Effects.*—The *physical* effects of the passage of electricity through the body are *heat*, and the *modification of endosmose and exosmose*, and the transference of *substances from one pole to the other*.

The heat excited in the body by the simple passage of a weak current that causes no muscular contraction, is small; but there is little question that heat is thus excited, although it is difficult or impossible to measure it by the thermometer. The main arguments in favor of this belief are (1), that all conductors of electricity become heated more or less in proportion to their resistance—the body offers great resistance, and more or less of the electric force must be converted into heat; and (2), *powerful* currents, either galvanic or faradic, even when not used so as to excite muscular contractions, cause increase of heat in the track of its passage, so marked as to be easily detected by the touch. No thermometer is necessary to show that in electrolytic operations, where strong currents are used, the tissues near the needles, and between them, become intensely heated, so that to rest the finger on them almost causes pain. This fact we have demonstrated over and over again in various parts of the body. It is equally clear that the faradic current, even when not very powerful, raises the temperature of the parts through which it passes. The sensation of the patient and palpation by the operator demonstrate this beyond doubt. Cold extremities are warmed sensibly and quite rapidly by faradization or galvanization, even when no sensible muscular contractions are produced by the current. It is logical to infer that very *weak* currents, either faradic or galvanic, cause a slight increase of heat by virtue of the passage of the current, and as a *physical* effect of such passage, without reference to the *physiological* phenomenon that must accompany the physical phenomena, which must probably also cause

a rise of the temperature. Schiff declares, as a result of his observations, that a nerve is warmed by an almost momentary passage of the current.

A second important physical effect of the passage of an electric current through the body is the transference of substances from one pole to the other. This physical effect of the current has long been recognized. In the electric light, for example, the particles of carbon go from the positive to the negative pole, and to so marked a degree that the positive carbon is quite rapidly worn away. A very remarkable illustration of this transference of matter in the track of electricity sometimes occurs in lightning stroke. Trustworthy cases are reported of individuals who have been found struck dead by lightning, and bearing on their bodies distinct images or impressions of some object, as a tree or house, near which they stood when they fell.

In 1864, at Nibelle, in France, three men who were gathering pears were struck by lightning. One was killed at once. The others were thrown to the ground unconscious, and one of these, when taken home, was found to have on his breast a "distinct daguerreotype of the tree."

In 1860 a woman of Sisonne, in France, who was struck by lightning, carried on her back a complete image of a tree—trunk, branches, and leaves—that was near the place where she fell. A similar case is recorded by Franklin.\*

The explanation of all these cases is the same. The particles of the tree, reduced to great fineness by the electricity, are mechanically transported and burned in the skin. The process is therefore not chemical, but mechanical and thermic.

Bodies have been literally tattooed in this way. Transference of substances is a part and result of the electrolysis in organic substances already described (Electro-Physics, p. 47), and also of the electrolysis of organic bodies to be hereafter described.

The electric currents also exercise a positive and very interesting influence over endosmose. By the passage of a galvanic current the endosmotic phenomena may be both stimulated or reversed. This is shown in the following experiment of Dutrochet: A tube containing gum-water is closed at one of its ends by animal membrane and dipped in a vessel containing common water. By the ordinary operation of the laws of endosmosis the gum-water rises in the tube on account of the entrance of some of the ordinary water through the membrane into

\* Death by Lightning, by M. Dr. Fedet (Clermont Ferrand), *Gazette des Hôpitaux*, June 8-10, 1872, translated in *The Clinic*, July 6, 1872.



the tube. But if the positive pole of a galvanic battery be placed in the common water, and the negative pole in the gum-water, the endosmotic action is stimulated to such a marked degree that the level of the gum-water rises with much greater rapidity; if we reverse the pole the level of the gum-water in the tube sinks instead of rises. The faradic current from the secondary coil produces no such effect. The current from the inner coil—the extra current so called—produces these effects to a less degree. It is pretty clear, therefore, that these phenomena depend on the *chemical*, and not on the *mechanical* power of the current.

*Electrical Endosmosis is influenced by Strength of Current and Resistance of Circuit.*—It is found that the quantity which rises is in exact proportion to the strength of the current, and to the extent of the porous surface. It has been found that the greater the resistance of the liquid to electrolysis, the more it yields to this endosmotic action.

The above phenomena have been demonstrated at different times, and by a variety of observers.

Besides the physical effects above described, there may be many others that we cannot at present recognize or appreciate, but which may be revealed by the spectroscope and other means of refined research.

*After Physical Effects of the Currents.*—It has been observed that platinum wires are contracted by the passage of electric currents through them, and that copper wires that are used for conducting electricity become brittle thereby. The differential action of the faradic and galvanic currents in this respect is quite interesting, for, according to Ruhmkorff, the copper wires that conduct faradic currents break more speedily and more frequently than those which conduct galvanic currents.

This physical fact is very suggestive of what may be facts in physiology and pathology. We have already seen that magnetization has physical effects of a most decided character. We have seen that it causes sounds to proceed from the body magnetized; that the body magnetized also becomes elongated; and that this elongation is probably due to the fact that the particles arrange themselves, during magnetization, lengthwise in the direction of the bar. It is not improbable that the human body in health and in disease may also be changed by the action of the currents in a manner that we do not yet comprehend, and that such physical or physiological changes may account for some of the therapeutic effects of electrization. This probability applies especially to the *after* effects of electrical treatment, effects that are noticed not while the applications are being made, or during the course of the treatment, but weeks and months after the treatment is discon-

tinued. On this subject we shall speak in more detail in the section on Electro-Therapeutics.

*Chemical Effects.*—The chemical effects of the current are mainly of an *electrolytic* character. They consist of an electro-chemical composition of the fluids of which the body is composed. The general laws and phenomena of electrolysis in its relation to inorganic substances have already been set forth in the chapter on that subject in Electro-Physics. It remains for us here to speak of electrolysis, in its relation to organic life. At the outset we may remark that there is no evidence that *organization*, as such, seriously modifies electro-chemical decomposition. The fluids of the body decompose under the influence of the current, just as the same combination of fluids with tissue would decompose if not endowed with life. If the results of the electrolysis of the dead body are different from the results of the electrolysis of the living body, it is because of the chemical changes that take place in the body after life has departed.

The human body is composed of fourteen different chemical substances, many of which are singly capable of decomposing under the current, and in their various combinations are capable of many decompositions and recompositions, with secondary results that cannot well be estimated.

The general facts of the electrolysis of inorganic substances, the appearance of oxygen and acids at the positive pole, and hydrogen and alkalis at the negative pole, apply also to the electrolysis of the living body. The great law arrived at by Faraday, that in electrolysis substances are decomposed in equivalent proportions (see Electro-Physics, p. 46), also finds no exception or interference in organic structures.

*Some of the Phenomena of Electrolysis of Living and Dead Tissues.*—In order to determine the electrolytic effect of the current on organic substances we have made a wide variety of experiments on both living and dead tissues, fluid and solid, in a normal as well as pathological condition, on animals and men. We have tried the galvanic current on the voluntary and involuntary muscles; on the mucous and serous membranes; on brain, spinal, and nerve matter; on the lungs, the heart, the liver, spleen, stomach, intestines, bladder, uterus; on the saliva and the urine; on the cartilage and on bones. The general conclusions at which we have arrived from these experiments are these:

1. All these animal tissues, living or dead, decompose, so far as can be seen, like inorganic substances, and by uniform laws.
2. The fact most patent to superficial observation is that the rapidity

of the electrolysis depends more on the amount of fluid in the tissues than on all other factors combined.

3. The great difference in the effects of electrolysis on organic and inorganic substances is seen after the current has ceased to act. In the electrolysis of most inorganic substances—such for example as iodide of potassium, acetate of lead, chloride of sodium, and so forth—the effects cease as soon as the current ceases; the substances remain in the condition that the current left them. The electrolysis of organic substances *starts a process that continues long after the current ceases to flow.*

*Electrolysis of the White of an Egg.*—When the white of an egg is electrolyzed by copper needles or wire, white flakes rapidly form around the needle connected with the negative pole, covering the needle as cotton covers a bobbin of a loom. This white covering soon becomes detached from the needle, if the current is tolerably strong, and floats on the surface of the albumen, and then another similar envelope is formed over the needle. In a little time the surface of the albumen becomes covered with white, slight masses, resembling what are known on our tables as “floating islands.” These formations are not coagula, as might be supposed, but are simply composed of hydrogen gas enveloped by very thin layers of albumen, into which it is mechanically driven by the electrolytic action, after the analogy of soap-bubbles and the froth of a beaten egg, where the distension is caused by common air enveloped by water and albumen.

Besides these changes the albumen becomes discolored, and reddish-yellow streaks are found at both poles. This discoloration is due partly to the action of the oxygen or the albumen on the copper of the electrodes.

Although, as has been said, *platinum* wires at the point of insertion into the substance are best for these experiments, since they are not acted on, and exhibit the changes in their purity, yet a common sewing or darning needle, or copper wire, will answer; but it should be borne in mind that the action of the substances on these will complicate the observation, and that they will in a short time become destroyed by oxidation.

*Electrolysis of Fresh Milk.*—When fresh cow's milk is electrolyzed with platinum needles an odor of chlorine is distinctly perceived, due to decomposition of the chloride of sodium, and little islands of foam appear on the surface. This foam, on being broken up, gives forth an odor of chlorine, and disappears, showing that it is not coagulated albumen, but simply chlorine gas and albuminous envelopes.

*Electrolysis of the Aqueous and Vitreous Humors of the Eye.*—When platinum needles connected with a galvanic current are inserted into the aqueous and vitreous humors of the eye of a dead or dying rabbit, rapid electrolysis takes place at both poles, with evolution of gases in albuminous envelopes. A cloud resembling cataract is speedily formed over the pupil, and in a few moments, if the current be of medium strength, the covering of the eye will be ruptured, with a violent escape of albumen-enveloped gases. This process, which Dr. Beard has frequently studied in the eyes of rabbits and dogs, is similar to that which takes place in the electrolysis of hydrocele and of certain cystic tumors.

*Electrolysis of Beef.*—It is possible to gain a measurably correct idea of what changes take place during and after electrolysis of the living body, in health or disease, by studying the phenomena that appear during electrolysis of dead tissue. If a piece of beefsteak, for example, be subjected to the action of the galvanic current by needles connected with the positive and negative poles, a process somewhat resembling frying can be distinctly seen and heard and felt; more specifically, bubbles of hydrogen appear at the negative pole, and a kind of hissing sound is heard, even when the ear is at some little distance, and a positive sensation of heat is felt when the finger is pressed over the part that is being electrolyzed. Under the microscope this process can be more closely studied. Chemical examination shows that oxygen, acids, and albumen go to the positive pole, while hydrogen, alkalies, and coloring matter go to the negative, and the action at the negative pole is much greater than at the positive. Under this process the beef becomes gradually dried and changed in color, owing to the disappearance of the watery constituents and the other electrolytic action; and, in proportion as the beef grows drier and the fibres begin to lose their adherence and fall apart, the electrolytic process becomes less and less active, because there is less fluid on which to act.

For some hours after the needles are removed, the process of drying and disintegration and decoloration goes on, until the portion that lies between and near the poles shrivels, contracts, and crumbles, until it resembles the burnt corners of a piece of roast beef.

*Electrolysis of Fruits and Vegetables.*—We have experimented on a variety of fruits and vegetables—as oranges, lemons, apples, pears, peaches, potatoes, turnips, etc. The effects of the electrolytic action, as they appear to the eye and the ear, though consistent with the great general laws of electrolysis of inorganic substances, yet are more or less modified by the varieties of structure. When a sound apple is electrolyzed, the part around the negative needle changes in color and look

as though it had been bruised and was beginning to decay, and the needle soon becomes loosened and will easily fall out. The process of drying and decoloration goes on after the operation is discontinued. In fruits and vegetables the electrolytic changes that take place are largely due to the electrolyzation of water, which is aided by the acids that they contain.

When muscles have been separated from the body and submitted for several days to the action of a strong galvanic current, there have been found at the positive pole sulphuric, phosphoric, hydrochloric and azotic acids, and at the negative pole alkalies—as soda, potassa, and ammonia.

Legros and Onimus have shown that when an alkali, as carbonate of soda, is placed at the positive pole in electrolysis of the human body, and an acid—as tartaric acid—at the negative pole, the usual eschars have **not** been formed. This would seem to indicate that the cauterization in electrolysis is due in part to the acids and alkalies that result from the decomposition.

This cauterizing action is not solely due to the acids and alkalies, for, when other acids and alkalies are applied to the body, eschars of the same degree are not obtained. The current penetrates and pervades the tissues and induces various changes beyond and beneath the eschar, which changes continue long after the current is broken.

The phenomena above described all occur under the *galvanic* current, and with needles as electrodes.

The current from the primary coil of the faradic machines has some electrolytic power, and even the current from the secondary and tertiary coils is not without some chemical effect. It is not necessary to use needles or pointed electrodes of any kind in order to produce electrolysis; but with a sufficient strength of current the phenomena may be produced by large, flat, metallic surfaces. There is more or less electrolysis in all the ordinary applications of electricity to the body, whether made with metals or sponges, small or large.

*Physiological Effects.*—The physiological effects of electricity, properly so called, are those which take place by virtue of the *vital* properties of the body. The other effects above described—mechanical, physical, and chemical—are not peculiar to living bodies; they are observed on the dead as well as the living, on inorganic as well as organic substances, although they are, as we have seen, more or less modified by vitality. But the physiological effects of which we are here to speak are peculiar to organization; they cease when life ceases, for they are mainly the modification of the vital processes by electricity.

There are in general *four* ways in which electricity applied to the tissues modifies their physiological functions :—

1. It may increase them.
2. It may diminish them.
3. It may arrest them.
4. It may modify their quality.

Some of the more important illustrations of their effects have been already discussed.

We have seen that electricity, according to the kind that is employed, and according to the method and strength and length of the application, causes various phenomena on the skin, contracts voluntary and involuntary muscles when applied either to the muscles themselves or to the nerves that supply them, and increases the process of oxidation, and raises the temperature, excites the nerves of common and special sense so as to cause pain, flashes before the eyes, noises in the ears, and a peculiar taste and odor. When applied to the pneumogastric it increases, diminishes, or arrests the action of the heart.

It remains here to speak of the following physiological effects of electricity :—

1. On the circulation.
2. On secretion and excretion.
3. On absorption.

The effect of electricity on the circulation is somewhat complex. It includes the effect on the heart and on the unstripped muscular fibres of the arteries, as well as on the central and peripheral nervous system in general, since the flow of blood in the arteries, veins, and capillaries is influenced by the quality and quantity of innervation that they receive. We have to speak merely of the direct effect of electricity on the capillary circulation. It has been shown already that electrization of the cervical sympathetic may have the directly opposite effect of contracting or dilating the vessels of the retina. That the same opposite effects may follow electrization of any part or organ, depending on the temperament of the patient, the quality of current, and the length and strength of the application, is also demonstrable. One effect is constant under all conditions, and that is, that the circulation is modified in one or the other, or in both ways. The average ultimate effect is to increase the *flow of blood, raise the temperature, and dilate the veins*. Dilatation of the veins, after prolonged electrization, is a phenomenon that can be demonstrated with ease on any part of the body where the

veins are prominent. The back of the hand is the best place to study this phenomenon, and faradization illustrates it most distinctly.

This enlargement of the veins is accompanied by a rise in temperature, and especially if the muscles have been brought into vigorous contraction, that is not only indicated by the thermometer, but is appreciated by the subject. Under general faradization the hands and feet become warmer during the sitting, and may remain warmer for hours. Central galvanization, or galvanization of the cervical sympathetic, also warms the periphery.

*On Secretion and Excretion.*—The secreting power of the secreting organs of the body is very markedly influenced by electrization. The usual effect is to increase their activity; but when very mild currents are used, such effect is not always observed, and it is probable, from our experiments, that very strong currents may produce a reverse effect.

On the *lachrymal glands* the action of the current is not so easily shown, because strong currents are not well borne on the face or head, and the glands themselves are not directly accessible. It is difficult to decide whether the flow of tears that accompanies strong electrization of the face is the result of the mechanical irritation or the physiological action of the current on the lachrymal glands or the nerves that supply them.

The secretion in *mucous membranes* is quickly increased by electrization, as can be demonstrated most easily on the Schneiderian membrane by means of metallic electrodes introduced in the nasal passages. This fact becomes of practical importance in the treatment of the so-called "dry catarrh," and also in exhausting diseases, associated with dryness of the mucous membranes.

On the *salivary secretion* the effect of the current is very easy of demonstration. That application of the current, both galvanic and faradic, can increase the secretion of the salivary glands, is very easily demonstrated. We have shown this at various times during the past five years, galvanizing or faradizing the tragus of the ear, with either pole, or against the membrana tympani. This effect is due to the excitation of the chorda tympani nerve, some of the fibres of which go to the submaxillary ganglia. This increase of saliva is sometimes so great that, while the current is flowing, continual swallowing is necessary.

In sensitive persons the same effect follows, by reflex action, electrization in almost any part of the neck or face. In certain pathological cases, as Addison's disease, Dr. Rockwell\* has found the annoying dry-

\* See Case 187.

ness of the mouth greatly relieved by electrization, and in pathological cases of the severe character, as in diabetes, when the salivary secretion may be greatly diminished, we have found central galvanization to increase the secretion quite rapidly.

On the *biliary secretion* the action of the current is less easy of mathematical demonstration. The results of external electrization in pathological cases seem to prove that the quantity of the bile may be increased. Whether this increase is due to the action of the current on the substance of the liver, or the nerves that supply it, we are not able to state.

The secretion of *gastric juice*, and of the *intestinal fluid*, is in all probability increased by external electrization. Analogy would show these fluids ought to be secreted in greater abundance under the influence of the current, and the results of treatment in pathological cases give this probability something of the force of certainty. Appetite is sharpened, digestion is quickened, and constipation relieved, both by local and by general electrical treatment, so rapidly and so decidedly as to make it pretty evident that the gastric and intestinal fluids are made to secrete more liberally by the action of the current on the nerves that supply these organs than on the tissues of the organs themselves.

An excellent means of studying the variations in the nutrition is found in the elimination of the urine. This is believed to be a result of oxidation processes that may take place either in the kidneys or in the tissues, or in both.

Legros and Onimus have studied the effects of electrization of the spine on the elimination of urine.

Their conclusions, derived from more than 250 analyses, made on the urine of rabbits and of themselves, are these:—

1. Interrupted currents diminish the quantity of urine and of azote.
2. Centrifugal galvanic currents increase the quantity of the urine and diminish that of the urea.
3. That continuous centripetal currents increase the quantity of urea without increasing the quantity of urine.

On the *urinary secretion* the effect of electrization can be demonstrated in pathological cases without difficulty. In cases of diabetes *insipidus* and *mellitus*, local and general treatment may cause great diminution in the discharge, while in dropsy and in rheumatism we have known the kidneys to be stimulated as much as by powerful diuretics.

On the average man in health there is considerable difficulty in estimating a moderate increase of the urinary secretion under electrization, for the sufficiently apparent reason that the quantity of urine



varies with so many conditions of food, drink, and exercise, and so forth. Unless the effect of electrization on the kidneys were immediate and decided, it would be difficult to differentiate between its effects and the effects of the other important and varying factors.

On the *menstrual secretion* electricity acts with remarkable power. Both currents, applied externally and internally, centrally or generally, in physiological as well as pathological cases, affect the quantity of menstrual secretion rapidly, and sometimes permanently. The effects are sometimes immediate, taking place during or directly after the application. The number of days that the menses appear are sometimes increased, and entire suppression is slowly or speedily cured.

In pathological cases, where there is an excess of menstrual flow, electrization corrects and diminishes it. These apparent and interesting effects of electricity on the menstrual secretion may take place through the direct action of the current on the ovaries and the uterus, or indirectly through the brain, sympathetic, and spinal cord, and the nerves that supply the pelvic organs. They may take place through reflex action from electrization of the feet or hands, or other and distant parts of the body. Franklinic electricity also produces these effects.

The whole subject is of immense practical importance, as will be seen in the chapter devoted to Diseases of Women.

On the *lacteal secretion* electricity, especially the faradic current, acts with decided though varying power. It has never been known to diminish it, while it sometimes increases it, and it may restore it after it has been temporarily suppressed. This physiological fact has a practical significance that will appear in the chapter devoted to Midwifery.

Similarly also the secretion of the *spermatic fluid* is increased by galvanization or faradization. A mathematical test of the power of electrization to increase the secretion of the testicles cannot, for obvious reasons, be obtained; but the statements of individuals on whom the experiment was tried seem to establish this point. The applications may be made not only through the testicles, but through the perinæum and over the spine. The results are not invariable, but are obtained in a sufficient number of cases to make it fair to regard such effect as a law of electro-physiology.

The secretion of the *sweat glands* is also increased by powerful galvanization of the central nervous system, and especially of the cervical spine and sympathetic. In very susceptible patients either galvanization or faradization of the head, neck, or spine, and strong electrization of almost any part of the body, will cause sensible perspiration. We

have seen individuals whom a few minutes of general faradization with feeble currents brought out large drops of sweat on the forehead, and made the hands as moist as though they had been dipped in water.

*On Absorption.*—The action of electricity on the absorbents is best studied in pathological cases, such as hypertrophies, effusions, and morbid growths.

In thickening of the skin that appears in some cutaneous affections, in corneal opacities, in enlarged joints, in pleuritic effusions, in hydrocele, in dropsy of various parts, in passive œdema, and in enlarged glands, in tumors of nearly every variety, can be demonstrated the power of electricity to produce absorption. Reasoning backward from pathology to physiology, we justly infer that the same effect takes place, more or less, in all applications of electricity to the body, but that the degree of it is modified by the condition of the part to which the application is made. The effect on secretion is apparent at once to the eye or the sensation; the effect of absorption is apparent only to the eye, and then only when there is a visible excess of fluid or solid in the part to which the application is made. This part of our subject will be practically illustrated in various chapters both in Medical and Surgical Electricity.

*Effects of Electricity produced by Reflex as well as by Direct Action.*—The reflex effects of electricity seem not to have been fully recognized by electro-therapeutists. There is considerable difficulty in ascertaining the precise reflex effects of electricity on animals. The effects as they show themselves on man are largely sensory, not motor; the stimulation of the circulation of absorption and of secretion that might and probably does take place, reflexly as well as directly, is too minute to be readily observed. We are justified in believing that electricity acts in absorption, secretion, and exertion by reflex as well as by direct action, from the fact that in irritable constitutions sensory effects on the sensation and on circulation, of a marked character, are produced by electric irritation. Thus, for example, when the hands or the feet are traversed by strong currents, either continuously or in sudden shocks, pain or disagreeable sensations may be felt in the hands and feet, of the opposite side, or in the back, or stomach, or side. These reflex effects are not constant, and when we look for them we may not find them. They can be best studied in persons who are susceptible to electricity, and whose spinal cords are weak and irritable. In some pathological cases also, such as chronic myelitis of the anterior column (anterior spinal sclerosis), the reflex action of electricity is illustrated with great distinctness. Localized faradization, or galvanization of the lower limbs

may be felt not only in the part traversed by the current, but in the arms, in the opposite limb, in the back, and stomach to such a degree as to cause pain.

Strong currents acting on irritable constitutions may sometimes by reflex action shock the whole system, provided the application be localized in certain localities. Thus in a case of very obstinate constipation that we once treated by internal galvanization of the rectum, a current of not very great strength, suddenly interrupted, was disagreeably felt in the head, left hand, and feet. Very frequently, indeed, in experimenting on ourselves or other individuals, or on animals, and in treating patients, we have received shocks through the hands or arms that seemed to be felt in all parts of the body. In some instances the pain and disagreeable sensations thus caused by the reflex action of the current last for several minutes or hours.

On the circulation the reflex effects of electrization are demonstrable by delicate apparatus for testing temperature. It has been shown by experiments that electrization of one hand affects the circulation in the hand of the other side, so as to change its temperature under the thermoelectric pile.

Powerful electrization of feeble persons may cause a general chilliness of the extremities that may last for hours. A sensation of having caught cold has been known to follow strong peripheral faradization.

Whether the action of the current on the retina and on the auditory and gustatory nerve is direct or reflex has been long disputed. Our researches induced us to the belief that electricity acts on the nerves of special sense both reflexly and directly. That the gustatory nerve can be treated by reflex action, we have shown in a variety of experiments with both currents. Sensitive patients appreciate the sour or metallic taste when the application is made to the lower part of the spine or to the arms. Similarly, flashes before the eyes may be produced when the electrodes are so placed that the current cannot traverse directly the region of the brain where the optic nerve takes its origin. Excitation of the auditory nerve by reflex action is not so easily demonstrated, but tinnitus aurium sometimes follows electrization of the spine and neck, and it is not unfair to infer that it is the result of reflex excitation.

In thus admitting the possibility of exciting the nerves of special sense, we do not desire to give the impression that the ordinary physiological excitation of these nerves under electricity is purely of a reflex character; on the contrary, we have shown already, in the chapter on Electro-Conductivity, that the current penetrates the brain and goes

through those parts where the optic nerves originate, and also must pass through the labyrinth and act directly on the auditory nerve.

In reference to the reflex effects of electricity these two considerations are of importance :—

1. The galvanic currents operate much more powerfully by reflex action than the faradic. The partial explanation of this fact which we offer is that the greater chemical power of the galvanic current, due to its acting always in one direction, causes it to operate more distinctly on the nerves than the faradic current. This fact of the superior reflex capacity of the galvanic current is one of high practical import in the treatment of disease, and explains in part, if not entirely, the dangerous, or at least unpleasant, effects that sometimes follow careless or ignorant galvanization in cerebral hemorrhages and other irritable conditions of the central nervous system.

Althaus has recorded a case of anæsthesia of the fifth pair of cerebral nerves of a most profound character, in which there was a complete absence of cerebral symptoms—dizziness, flashes of light, and galvanic taste—whenever a galvanic current of twenty cells was applied to the face. A current from thirty cells, which on a person in health would cause powerful flashes, a hissing sound in the ears, feeling of heat, and perhaps perspiration, caused in this patient only a slight sensation of giddiness and metallic taste and phosphoric odor.

This remarkable case is a strong argument in favor of the opinion that the results of electrization of the head and the results of experiments like those of Erb are due in part, if not entirely, to reflex action.

It is possible that in the above case the portion of the brain where the optic nerve originates was also diseased so as to render it insensible to electric excitation.

2. These reflex effects occur in all the applications of electricity of either form, and complicate the direct effects. The physiological and therapeutical effects of electrization of the brain, the eye, the ear, the cervical sympathetic, the spine, the trunk, and the periphery, everywhere are a complex resultant of both direct and reflex electrical action. *Localized* electrization, strictly speaking, is an impossibility, however closely together the electrodes may be placed, and however distant from the great nerve tracts and nerve centres the spinal cord must take cognizance of the impression made by the current on the sensory nerves, and other parts and organs must share in the effects, for better or for worse. It is for this reason that caution is requisite even in faradizing the paralyzed muscles in recent hemiplegias and in active myelitis.

The very remarkable results that follow general faradization—a method to be subsequently described—are to be accounted for in part by reflex actions, which are continually taking place during all stages of the application.

*Practical Application of these Physiological Principles to Electro-Therapeutics.*—With the above facts and reasonings before us we are prepared to intelligently appreciate the effect of *electricity on nutrition*. We do not profess to have exhausted the *rationale* of the complex action of electricity on the tissues, but to have indicated the leading principles by virtue of which it affects the nutrition of the animal body. Many discoveries may yet be in store for us in this department; it may be shown that ozone is generated in the tissues with every passage of the current, and that this ozone is taken into the circulation; the subtle and intricate chemistry of electrolysis of living tissues in their secondary and tertiary, as well as their primary changes, may be unfolded to the vision of the future, and what we now see in a glass darkly posterity may behold face to face; but sufficient is known to explain in a most interesting way the unrivalled effect of electricity on the nutrition.

An objection sometimes brought against electricity is that we do not understand its action; and yet in the whole round of stimulating tonics there are but few whose action can be so well explained as that of electricity. Who knows how arsenic feeds the nervous system or how quinine breaks an attack of chills and fever? Why does oxide of zinc act with magic force in chronic alcoholism? How does opium produce sleep and relieve pain; and who has entered into the mysteries of anæsthesia?

Animal nutrition is a process of enormous complications. There is no single chemical change at which one can point and declare that this explains the growth and sustenance of the body; but there are nameless and numberless phenomena every moment going on in the living tissues, and as a result of all these, in their infinite play and combination, the body lives, moves, and has its being. Electricity in passing through the body modifies many or all of these processes, and thus modifies nutrition. As a resultant of the complex physical, chemical, and physiological action of electricity on the tissues, there is increased development and growth.

*Experimental and Clinical Proofs of the Effect of Electricity on Nutrition.*—We have studied the effect of electricity in great detail on animals and on man. On animals our experiments have been confined to the effects of general faradization; on man we have studied the effects of both localized and general treatment.

Of a litter of four puppies, Dr. Beard submitted two to general faradization every other day, for eight minutes each, and two were not so treated, all having an equal chance at their mother's breast and nothing besides. All the puppies were carefully weighed at the beginning and at the end of the treatment, which lasted for four weeks. It was found that both of the pups that had been electrized weighed more than the puppies that had not been electrized; all had, of course, increased in weight, but of those electrized one had increased *four* ounces and the other *ten* ounces more than his fellows that had not been electrized. The difference of size in favor of the puppies that were electrized was so marked and so easy to see, that without great difficulty one who had never seen them succeeded in picking out, from ocular inspection, those that had been treated, and that too in the evening, and in a bad gas-light. It was observed during the treatment that the puppies which were electrized became ravenous, and sucked with greater energy than their less-favored companions.

The method of treating the pups, we may remark, was to put them on a sheet of copper, while the hand of the operator or a sponge-electrode was rubbed all over the surface of the body, previously moistened.

The details of the experiments, prepared by our assistant, Dr. J. W. Sterling, who made the applications, are as follows :

July 1, 1871.—Weight of 4 pups, 10 days old :

2 black pups (weight each) . . . . . 1 lb. 6 oz.  
 2 yellow pups, weight of one . . . . . 1 lb. 3½ oz. ; other, 1 lb. 2½ oz.

July, 1, 1871.—Commenced general faradization, each application about 8 minutes. Applied it to one of the black pups, weight 1 lb. 6 oz., and the lightest of the yellow pups, weight 1 lb. 2½ oz.

Continued the applications four weeks, making three each week.

July 28, 1871.—Weighed the pups after twelve applications.

1 black pup (general faradization) . . . . .	3 lbs. 7 oz.
1 black pup (no faradization) . . . . .	2 “ 13 “
1 yellow pup (general faradization) . . . . .	3 “ 0 “
1 yellow pup (no faradization) . . . . .	2 “ 12 “

Making a clear gain for the *electrized pup* (black) of 10 oz., for the yellow electrized pup, 4 oz.

This we believe, was the first comparative experiment of this kind made with the faradic current. Subsequently, Dr. Beard repeated the experiment on a litter of three rabbits. Two were faradized every other day; to the other no treatment was given. At the end of six weeks the

one not treated was visibly larger than either of those that were treated. We explained this unexpected result by the theory that the current had been used too strong and too long for the young and delicate animals. The experiment was carried on while we were in the country, and the details were intrusted to those who were utterly incompetent for their duties. The directions given were to put the feet of the rabbits in a basin of tepid water, and after well moistening the back of the neck to pass the current through for ten minutes; on account of the non-conductivity of the dry hair of the rabbit, general faradization was almost impossible.

Legros and Onimus electrized with the *galvanic* current some puppies for a quarter of an hour every day, by placing one of the fore-paws and one of the hinder-paws in tepid water connected with the electrodes. At the end of six weeks those that had been electrized weighed more than the same lot that had not been electrized; and this difference was perceptible to simple inspection; one was galvanized with the ascending, and the other with the descending current.

The effect of faradization on nutrition is powerfully illustrated by the experience of those who habitually or frequently apply general faradization through their own persons, taking an electrode in one hand, and applying the other to the body of the patient. In this method the current passes through both arms, and vigorously contracts the muscles.

The *permanent* effects of the current on the person of the operator are :

1. *To cause very marked and sometimes rapid growth of the muscles of the arms.*

The explanation of this phenomenon is sufficiently easy. The muscular contractions that are produced by the current in its passage through the arms cause increase of the local processes of waste and repair, and accordingly the muscles increase in size, just as they naturally do under the influence of any other form of active or passive exercise. This mechanical explanation would be of itself sufficient, but, in addition, it is entirely probable that the electric current exercises a direct and specific influence on the nerve-branches, which effect is expressed by the increased size and vigor of the muscles through which the nerves ramify.

Dr. Rockwell, during his first experimental attempts in the treatment of disease by general electrization, observed a decided increase in the development of the muscles of the arm. It began to force itself on his attention a few weeks after he commenced to give special attention to general electrization, and at the present time it is fully as marked as

ever. Both arms of each one of us have not only increased much in size by actual measurement, but also correspondingly in strength and hardness. This effect is observed in the arm and forearm, but most decidedly in the muscles which, from their position or nerve supply, contract most readily and vigorously when the current passes from hand to hand, such as the deltoid, brachialis anticus, biceps, and the flexors and extensors of the forearm. This same effect has been noticed, to a greater or less degree, by our students, and, so far as we have been able to ascertain, by others, who have employed electricity through their own persons for any considerable period. This development of the arms seems to progress up to a certain limit, at which it remains.

2. *A very gradual but decided tonic influence on the system.*

This effect is so exceedingly slight, that in a very hardy and vigorous person it would not be recognized. That the current, in passing from hand to hand, so frequently and so long, should, in the course of time, mildly affect the general system, is entirely probable. Like any other muscular exercise of the arms—gymnastics and the use of the clubs—its influence, so far as it goes, must be positively toning and beneficial to the constitution.

*Effects of Electricity on Bacteria.*—Cohn has experimented with electricity on bacteria.\* Currents from two powerful elements, sterilized the nutritive solution completely at the positive pole in twelve to twenty-four hours, so that afterward the bacteria produced did not increase. At the negative pole the action was weaker, the liquid not being completely sterilized. At neither of the poles were the bacteria killed, and when brought into another nutritive fluid they developed normally.

Yeast-cells, on the other hand, and mycelium fungus, brought into the liquid that was sterile for bacteria, increased plentifully at the positive pole. A battery of five strong elements killed the bacteria distributed in the liquid within twenty-four hours and sterilized the liquid at both poles.

*Effect of Electricity on the Growth of Plants.*—The influence of electricity on the growth of plants has recently been studied by Mr. H. H. Bridgeman, of Norwich, England. On a plate of glass three inches square, two strips of sheet-tin are laid, so as to almost touch in the centre. On this glass, and over the tin strips, is spread a piece of felt moistened with rain water. On its dampened surface cress-seeds are thickly strewed. The tin plates are connected with the poles of a weak

\* *Med. Press and Circular*, June 9, 1880.



galvanic battery ; the result is that one-half of the felt is charged with positive and the other half with negative electricity. At the side of this plate is a second plate, which has connection with the battery, and upon which the seeds grow, subjected to no artificial conditions. After four days the seeds on the opposite side of the first piece of felting gave signs of germination, and the hulls were shrivelling up and becoming black. On the negative side of the felting the seeds were swollen, and their hulls, which retained their natural color, were beginning to burst. At the end of six days the first shoots made their appearance. Several days later the first shoots appeared upon the second plate. A strange result of this trial was, that while on the negative pole, where there was every sign of stronger development, the root-sprout sank downward into the moist felting, the roots from the positive side rose upward from the blackened and dried-up seeds.



# ELECTRO-THERAPEUTICS.

## CHAPTER I.

### HISTORY OF ELECTRO-THERAPEUTICS.

*Electro-Therapeutics is the science that treats of the study of electricity in its relation to disease.*

It includes both *Electro-Medicine* and *Electro-Surgery*, or as they are more commonly termed, *Medical* and *Surgical Electricity*. Under Medical Electricity are included *Electro-Diagnosis*, or *Electro-Pathology*, as it is sometimes termed, and *Electro-Therapeutical Anatomy*.

The earliest history of electro-therapeutics, as of many other departments of medicine, is shrouded in obscurity. It dates back to a mythical and legendary age, before mankind had been trained to habits of scientific criticism, while yet history was a mass of traditions, and rumor was a substitute for truth.

It is said that centuries ago the negresses of West Africa were accustomed to dip their sick children in water where lay the electric fish called the torpedo. The remedial powers of electricity were also referred to by Pliny and Dioscorides. Scribonius Largus, a physician of the time of Tiberius, was accustomed to prescribe the same remedy in the treatment of gout. As long ago as the days of Pliny, necklaces of amber were worn by women and children for the sake of their supposed remedial powers.

The mysterious power of the magnet was known to the ancient world, but we have no reason to believe that it was ever extensively resorted to by them for the cure of disease. In Europe, during the middle ages, the loadstone was used in the treatment of disease, and although its successes were trifling it aroused the professional attention and received extravagant praise from the distinguished Paracelsus. About the middle of the eighteenth century, Maximilian Hehl, of Vienna, and others, excited a new and more successful interest in the use of magnetism in disease by the manufacture and employment of artificial magnets.

The real history of electro-therapeutics may be divided into *three eras*: the *Era of Franklinic Electricity*, including the early and crude experiments with the frictional machines and the Leyden jar; the *Era*

of *Galvanization*, beginning with the publication of the discovery of Galvani, in 1791, and including the invention and medical employment of the voltaic pile; the *Era of Faradization*, beginning with the discovery of induction, in 1831-32, and including all that has since been accomplished in the department of localized and general electrization.

In the first era only *franklinic* electricity was used, because it was the only form that was known; in the second era, both *franklinic* electricity and galvanism were used, since the latter supplemented, but not entirely supplanted, the former; in the third era, all three forms of electricity—franklinic, galvanic, and faradic—were brought into requisition, though the use of franklinic is confined to a few, and will probably soon become historic.

*The Era of Franklinic Electricity.*—The records of this era, though not extensive, are yet both interesting and suggestive. It is probable that in this, as in the second era, very much was attempted and even accomplished in this department that has never been recorded in permanent medical literature, and therefore could never become of value to science.

In 1730 Etienne Grey first observed divergence of the hairs in an isolated subject put in communication with static electricity.

The same experiment was repeated by Abbé Nollet and Du Fay. Du Fay observed the electric sparks drawn from the isolated subject.

Nollet says, "I shall never forget the surprise which the first electric spark ever drawn from the human body, excited both in M. Du Fay and myself."

Sparks were then drawn from the body in various shapes—one of which was called the electrical kiss; other forms were known as the "electrical star," "electrical rain," and so forth. The drawing of the sparks constituted a great source of amusement in the society of the period.

In 1743 Kruger d'Helmstadt suggested that these electric sparks might be made of service in therapeutics.

In 1744 Kratzenstein, a German physician, recorded a case of cure of paralysis of the fingers by sparks drawn from a frictional apparatus.

In 1746 the discovery of the properties of the Leyden jar by Muschenbroek gave physicians a new means of using electricity in the treatment of disease.

In 1749 Jallabert,\* of Geneva, published a treatise on the medical use of electricity, in which he reported a cure of long-standing paralysis

\* *Experiences sur Electricité*, Paris, 1747.

of the right arm, resulting from injury, by electric sparks. The cure was brought about in two or three months, and may perhaps be regarded as the first decided and unquestioned result of the kind that was obtained in the early days of electro-therapeutics.

1750 Nebel showed that contraction of the muscular tissue was produced by electrization.

Bohadtch, of Bohemia, also recommended electricity, especially for the treatment of hemiplegia.

In 1753 Lindhult, a Swedish physician, reported a cure of epilepsy by electricity.

In 1754 Sulzer made his famous experiment on the tongue with zinc and copper plates. (See Electro-Physiology). He did not, however, pursue his experiments, and it was reserved for Galvani and Volta to discover galvanism.

In 1755 De Hæn reported a large number of electrical cures of paralysis, spasmodic and other nervous affections, and also of suppression of the menses, and St. Guy's dance. About this time, also, Schaeffer and Nebel published cures of rheumatism, toothache, hypochondria, paralysis of the optic nerve, and of intermittent fever and neuralgic pains. Between 1750 and 1757, cures of paralysis were reported by Brydone, Bertholon, Sauvages of Montpellier, and Spry, the latter of whom cured a case of lockjaw and paralysis.

The position that electro-therapeutics held at that time, and the hopes that were entertained of it, is very well represented in a little treatise by the eminent divine, Rev. John Wesley, entitled, *The Desideratum; or, Electricity Made Plain and Useful, by a Lover of Mankind and of Common Sense.* 1759.\*

In this treatise the author anticipates, in a sort of theoretical way, very much that has since been demonstrated, both in electro-physics and electro-therapeutics, and with surprising accuracy. In the preface he acknowledges his indebtedness "to Mr. Franklin for the speculative part, and to Mr. Lovett for the practical." He also mentions as authorities, Dr. Haadley, Mr. Wilson, Watson, Freke, Martin, Watkins, and the *Monthly Magazine*, whence we may conclude that even at that early day the subject was exciting much interest, but more among the laity than in the profession.

From the tone of the book it is clear that the Faculty, as Wesley calls the profession, were disposed to despise electro-therapeutics

\* This treatise has been recently republished by Baillière, Tindall & Cox. London, 1871.

and to reject its claims, as they have been ever since, until within a few years, and consequently they suffered what was really valuable in medicine to be monopolized by the laity.

The mind of Mr. Wesley, as the world knows, was of the practical sort, and in this treatise he does not suffer himself to be carried away into gross hyperbole or serious untruth. He expressly disclaims any idea of regarding electricity as a panacea, but says what we now know to be true, that it is indicated in a wide range of disorders; but that if any one agent should ever become a panacea, electricity stood the best chance of being that agent.

Evidently ignorant of Franklin's invention of lightning-rods, in 1775, he suggests that buildings and ships might be saved from the effects of lightning, by "upright rods of iron, made sharp as needles and gilded to prevent rusting," and connected with the earth. He further suggests, that the northern lights are of electrical origin.

He gives the following list of diseases in which electricity is of service, with a number of illustrative cases, most of which are very imperfectly detailed. It will be observed that most of these diseases are still treated electrically, and with greater or less success. It seems from the list that the treatment of diseases of the skin by electricity is simply another attempt to effect what was accomplished with success more than a century ago.

All these conclusions of Wesley and his contemporaries were, however, based on experiments made with franklinic electricity. The world was to wait forty-one years for the Voltaic pile, and seventy-two years for Faraday to discover induction.

"Agues, St. Anthony's Fire; Blindness, even from a Gutta Serena; Blood Extravasated; Bronchocele; Chlorosis; Coldness in the Feet; Consumption; Contraction of the Limbs; Cramps; Deafness; Dropsy; Epilepsy; Feet violently disordered; Felons; Fistula Lacrymalis; Gout; Gravel; Head-ache; Hysterics; Inflammations; King's Evil; Knots in the Flesh; Lameness; Leprosy; Mortification; Pain in the Back, in the Stomach; Palpitations of the Heart; Palsy; Pleurisy; Rheumatism; Ringworms; Sciatica; Shingles; Sprain; Sore Feet; Swellings of all kinds; Throat sore; Toe hurt; Tooth-ache; Wen."

In 1763 Watson cured a case of general tetanus in a young girl of seven years. Although the fame of the cures wrought by electricity attracted crowds of invalids, yet by the ignorant and superstitious it was confounded with witchcraft, and the aid of the priest was invoked to save them from its baneful influence.\*

\* *A Treatise on Medical Electricity, Theoretical and Practical* By J. Althaus, M.D. 1870, p. 284.

Abbé Sans published a work on the medical use of electricity, and recorded important cures. According to this authority, there were seven different methods of employing static electricity—"an electric bath, drawing sparks, by irroration, friction, insufflation, exhaustion, and commotion." Injurious and negative as well as favorable results were sometimes reported. Thus Dr. Hart brought on paralysis in a girl, and Abbé Mazras excited epilepsy in one of his patients. Benjamin Franklin failed to cure the invalids that flocked to him after his great discovery, and Abbé Nollet, after many years' experience, was compelled to admit that he had seen but little permanent benefit from electricity.

*Symptoms only treated in these early Experiments.*—In these early and many of the later experiments, not disease, but the results of disease, were both studied and treated. When electricity was applied, it was to the symptoms and not to the pathological condition; hence the enormous blunders and frequent failures of the early electro-therapists. The symptoms most treated, and in the treatment of which the greatest hopes were entertained, were blindness, deafness, paralysis of motion, symptoms which are now known to depend, in very many instances, on pathological states, which are in their very nature as incurable as death itself. Still further, the applications were made to the seat of the symptoms exclusively, instead of to the seat of the disease, and this mistake helped to swell the number of the failures.

Physiology and pathology had not yet reached that degree of strength and breadth of sureness to furnish good foundation on which to erect the science of electro-therapeutics, and withal the appliances for generating electricity were bulky and untrustworthy.

Electro-therapeutics was therefore baffled in its first attempts at growth, through lack of needful support from allied and fundamental sciences; it must wait for physics, for physiology, for pathology to come to its rescue, which in due time they have done and are now doing.

In 1773 and 1778 Maduyt presented memoirs \* † on the subject, in which he affirmed in his report that electricity was a remedy of vast and varied powers; that it had a positive and very beneficial influence over nutrition; and that it equalized the circulation, materially affected the pulse, the perspiration, and the secretions; and was surprisingly

\* Mem. sur les effets généraux, la nature et l'usage du fluide électrique considéré comme médicament. Lu en décembre, 1778, à la Société royale de médecine.

† Mem. sur les différentes manières d'administrer l'électricité, et observations sur les effets que ces divers moyens ont produits. Lu en décembre, 1783, à la Société royale de médecine.



efficacious in the treatment not only of paralysis, but also of other conditions, such as constipation and œdema. This report aroused considerable interest in electro-therapeutics on the part of the profession, and for a season the application of franklinic electricity became extensively popular. In 1777, Cavallo published a work \* which excited considerable attention. He reported cures of epilepsy, paralysis, cœcœa, deafness, blindness, rheumatism, glandular enlargements, and recommended electricity as a means of artificial respiration.

On the theory that medical substances might be combined with electricity, Pivati, of Venice, placed in his electric machine a glass cylinder, filled with Peruvian balsam, and Giuseppe Bruni affirmed that, by the same arrangement, filled with purgatives, he had produced the same effect on an electrified patient as though the remedy had been administered internally.†

In 1783 Wilkinson presented the results of some experiments with electricity in England. Although the fame of the cures wrought by the new remedy attracted thousands of the people, yet by the ignorant and superstitious electricity was confounded with the spirit of evil.‡

Of the seven methods of employing statical electricity recommended by these early experimenters, but three were in common use. These were, the *electric bath*, *electrization by sparks*, and *shocks from the Leyden jar*.

*The Era of Galvanization.*—Animal electricity was discovered by Galvani in 1786, and made public in 1791. It was by the experiments of Galvani that Volta was stimulated to investigate the subject of electricity. He denied the existence of animal electricity which Galvani had discovered. One of the most important fruits of the discussion that arose between them and their respective followers was the construction of the voltaic pile, which for many years physicians employed, with various alternations of failure and success, in the treatment of disease.

In the period intervening between the discovery of animal electricity by Galvani, and the construction of the pile of Volta, electricity was applied to the body by means of metallic plates, joined together by a metallic arc. Sometimes these were simply placed against the skin, and sometimes over spots denuded by a blister.§

\* A Complete Treatise on Electricity, in Theory and Practice, with original Experiments. Londres, 1777. Id., Medical Electricity. Londres, 1780.

† Althaus, op. cit., p. 287.

‡ A. Tripier, Manuel d'électro-thérapie, exposé pratique et critique des applications médicales et chirurgicales de l'électricité. Paris, 1860. § Tripier, op. cit., p. 262

In 1792, Behrend, Creve, and Klein suggested the use of galvanism as a means of distinguishing real from apparent death. The first attempts to make galvanism of practical service in the treatment of disease were made by Professor Loder, of Jena. The results of his experiments were unsatisfactory.

In 1793 Hufeland and Reil advised the use of galvanism in paralysis.

In 1796 Pfaff advised the same remedy for amaurosis. None of these authorities spoke from much personal experience.\*

In 1797, Alexander von Humboldt † suggested, on theoretical grounds, the use of galvanism in paralysis, rheumatic pains, and diseases of the eyes.

Valli actually restored to life, by galvanism, frogs and fowls that had been nearly suffocated. ‡

The voltaic pile, invented in 1800, marked an era in the medical use of the galvanic current, because, with all its imperfections, it was vastly superior, for therapeutic purposes, to the metallic plates that had previously been employed during the period which had elapsed since the discovery of Galvani. It was at once employed by Loder, in Jena, by Grapengiesser, § Bischoff, and Lichtenstein, in Berlin, and by Haller, in Paris, chiefly in cases of paralysis.

In 1801, Augustin, of Berlin, published a treatise on galvanism, in which he reported results of treatment of paralysis by applying the negative pole to the central end the nerve, and the positive to the peripheral. Prof. Schwab experimented with the voltaic pile in cases of deaf-muteism. In 1802 Sigaud de la Fond published a work in which he recommended franklinic electricity for nearly every form of disease. In 1804, Aldini, a pupil of Galvani, published a treatise on galvanism, in which he theoretically recommended it for deafness, insanity, and amaurosis, and also to produce artificial respiration. ||

Even during this era, and for many years after the invention of the voltaic pile, franklinic electricity was still employed.

In 1817 Dr. Thomas Brown, of Albany, published a work entitled "*The Ethereal Physician*," in which he recommended franklinic electricity for paralysis, tic-douloureux, epilepsy, chorea, and in a large variety of disorders.

\* Tripier, op. cit., p. 263.

† Versuch über die gereizte Muskel und Nervenfaser. Berlin, 1797.

‡ Expérience sur le galvanisme, traduit par Jadelot. Paris, 1799.

§ Versuche den Galvinismus zur Heilung einiger Krankheiten anzuwenden. Berlin, 1801. || Essai théorique et expérimenta sur le galvanisme. 1804.

In 1818 Dr. Everett, of New York, published something on the use of electricity in medicine that was based on experience that he had derived with the apparatus of Dr. Brown.

In spite of all these endeavors on the part of scientific men to give importance and dignity to the cause of electro-therapeutics, it failed to fulfil the extravagant expectations that had been formed of it; a reaction followed, and it fell into disrepute. Electricity had been tried for a wide range of diseases, but partly on account of the inconstancy of the voltaic pile, and partly through the ignorance of the operators, it was found to be a most uncertain remedy. It was confounded with mesmerism, which at this period came into notoriety, and for a time it shared its fate.

*Many of the early Experiments made by the Laity.*—It will be seen by a glance at the above-mentioned names that the earliest experiments in electro-therapeutics were made by the laity. A science that now commands some of the best brains of civilization was born among the humble and the lowly. It was cradled in ignorance and reared and fostered by those who, however eminent in other walks, knew little or nothing of medicine. Chemists, physicists, priests and paupers, monks and mountebanks, were in the eighteenth century the leading authorities in electro-therapeutics. If there were those at this time who had faith in the coming of a better day, when electro-therapeutics should be a recognized and permanent part of the medical science, it was their misfortune to die without the sight. Not until the close of the eighteenth century were the great discoveries of Galvani and Volta revealed to the world, which was to work and wait for at least half a century before it should see even the beginning of the fulfilment of its hopes. Some of the great sciences, like some of the great religions, have had the humblest origin.

Of the early history of electro-physics, Whewell\* thus remarks:—“At such a period a large and popular circle of spectators and amateurs feel themselves nearly upon a level in the value of their trials and speculations with the more profound thinkers; at a later period, when the subject is becoming a science, that is, a study in which all must be left far behind who do not come to it with disciplined, informed, and logical minds, the cultivators are far more few, and the share of applause less tumultuous and less loud. Electricity, to be now studied rightly, must be reasoned upon mathematically.”

What Whewell here says of electro-physics may just as truly be applied to electro-therapeutics.

\* History of the Inductive Sciences, 2d ed., vol. ii., p. 200.

In the earlier experiments, the philosopher and the fool were pretty nearly on the same level in their knowledge of the application of this subtle force to the treatment of diseases, with this advantage on the side of the fool, that through the very excess of his ignorance he dared and ventured where the philosopher knew just enough to fear to tread.

It was, as we shall see, a long time before electro-therapeutics should be gradually developed into a science of sufficient positiveness to command the attention of men of science for its own sake, and to excite the despair of the ignorant.

Here, as in all other realms of investigation, the development is from simplicity towards complexity, from generals to specials, and from truths that are common to all classes, to truths that only a few specialists can thoroughly master. We are reminded here of the beautiful thought of Thoreau. When reproached for his exclusiveness and love of solitude, he replied, "It is not so much that I love to be alone, as that I love to soar, and the higher I ascend, the company grows thinner and thinner, until at last I am left almost alone."

Strikingly this principle has been illustrated even in the most recent history of electro-therapeutics, both in Europe and America. A field now occupied by some of the ablest scientists of Germany, England, and France, was formerly crowded with lawless intruders.

When we began to write on this subject in 1866, a tide of inquiries at once set in upon us, from all parts of the country. The authors of these letters, with some few exceptions, we have never seen; but, judging from the style of composition and the character of the inquiries, they were as a rule comparatively ignorant, and belonged to the lower strata of the profession. Letters that we receive more recently during the past three years, evidently come from many of the best men in the profession. As the science develops, brains and culture are attracted to it. In our large cities, those who are studying this subject are among the most promising names in science.

In 1825, Sarlandière proposed the employment of acupuncture needles in galvanization, so that the current could be more exclusively and definitely localized on the desired nerve or organ. This method of treatment was called electro-puncture.\* He used for this purpose franklinic electricity. Subsequently Magendie successfully experimented with galvano-puncture in neuralgia, paralysis, and other nervous diseases.

The discovery of electro-puncture was the beginning of the science

\* *Mém. sur l'électro-puncture. Paris, 1825.*

of electro-surgery, a department which at that time commanded a wider interest than the medical use of electricity, and which has now a most important position in science.

Gerard and Pravaz suggested, and Pétrequin and Ciniselli succeeded in curing aneurism by galvano-puncture. Subsequently galvano-cauterization has been investigated by Steinheil, Middeldorff (1859), Amusat, Althaus, Byrne, ourselves, and many others. (For detailed history of the surgical uses of electricity, see Electro-Surgery, Chapter I.)

In 1826, Baumé published in London a work on galvanism, which two years later reappeared in a different form, and was translated into French by Fabre Palaprat, who was the first to use the *galvanic* current in electro-puncture.

*The Era of Faradization.*—The publication of the discovery of inductive electricity by Faraday, in 1831-2, changed the whole course of electro-therapeutics. On the basis of this discovery electric machines were constructed that were both more reliable and more convenient than the ordinary voltaic pile. The first magneto-electric machine was constructed by Pixii in 1832, and was first employed in the treatment of diseases by Neef of Frankfort. Afterwards electro-magnetic (volta-electric) machines were constructed by Neef, Clarke, Stöhrer, and others, which from time to time have been variously modified by a large number of experimenters in different countries.

From this time electricity in the form of faradization began to be extensively and indiscriminately employed, both in this country and in Europe. It was used by the laity as well as by the profession, though at first without any recognized method, and without any very clear ideas of the indications for which electrization was adapted. Since that time four distinct methods of *medical* electrization have been introduced, in which the galvanic as well as the faradic current have been appropriated, and under one or the other of which may be classed all the applications of faradic or galvanic electricity that have since been employed. These methods are *localized faradization, localized galvanization, general faradization, and central galvanization.*

*History of Localized Faradization.*—The history of localized electrization is identified with the name of Duchenne, whose experiments and discoveries have given such an impetus to this important and growing department. Duchenne was not, however, the first to employ localized faradization. Prior to his time, faradization had been used by Masson in France, and Neef of Frankfort; and in this country it has been employed by the profession and by the laity from the period of the first popularization of machines of induction.

Even as early as 1843 localized *faradization* was used in this country side by side with general faradization, though, like the latter, it had received no distinct nomenclature, and was indiscriminately recommended and unscientifically applied.\* The two methods, localized and general, were frequently confounded, and both were known under the vague term, "electrifying." Duchenne's earliest attempt to call the attention of the profession to this subject is thus recorded in his own words:—

"De l'art de limiter l'excitation électrique dans les organes sans piquer ni inciser la peau, nouvelle méthode d'électrisation appelée *électrisation localisée*, et dont les principes, résumés dans une note adressée en 1847 à l'Académie des Sciences, ont été développés et publiés dans les *archives générales* de Médecine en juillet et août 1850, et février et mars 1851." In 1855 he published his chief work, "De l'Electrisation Localisée, et de son Application à la Physiologie, à la Pathologie, et à la Thérapeutique."

This work became known to the profession in Germany through the abridged translation of Dr. Erdmann.

The leading idea of the method of localized faradization of Duchenne was, that the current can be localized over a fixed *point under the skin* if well-moistened conductors are strongly *pressed upon the skin*.

He observed—what is perfectly familiar to all experimenters in electro-therapeutics—that when dry electrodes are applied to the dry skin, sparks with a crackling sound are produced, but no sensation and no muscular contraction. He observed that when the electrodes are well moistened, contractions are excited in the muscles, with the phenomena of sensation.

He recommended three forms of electrodes—solid metallic electrodes, metallic brushes, and the hand.

On these observations and experiments Duchenne based a system of electro-therapeutics and electro-diagnosis which, as since refined, developed, and modified by himself and by numerous other laborers in various countries, has now grown into a permanent department of science.

Localized faradization was appreciated by electro-therapeutists more rapidly than some of the other methods of using electricity, as electrolyzation, general faradization, galvano-cautery, and central galvanization, for the reason that it is the easiest learned of all the methods and

\* In Pike's Catalogue of Mathematical, Optical, and Philosophical Instruments, 1848, there is a cut of the faradic apparatus that had been in use for five years by these early experimenters. The same work also contains a cut illustrating their method of localized faradization of the leg.

requires only the simplest and cheapest form of battery. To be an expert in it requires a degree of skill and experience and manual facility, as well as familiarity with the diseases for which it is indicated, and some knowledge of electro-physics and electro-physiology are of essential service; but in none of these respects is this method as exacting as any one of the others.

Hence it is, that localized faradization is the method with which novices usually begin their experiments in this branch, and it is the method which by the mass of the profession is now more used than any other.

Among specialists, however, of all countries, localized galvanization is more used than localized faradization, since it meets on the whole, as experience shows, a larger range of indications.

*History of Localized Galvanization.*—One of the ablest and most prominent of those whom the writings of Duchenne inspired to enter upon the study of electro-therapeutics was Professor Remak, of Berlin. His first work, "*Ueber Methodische Electricisirung Gelähmter Muskeln,*" "On the Methodical Electrization of Paralyzed Muscles," was published in 1855. In this work he revived and recalled the attention of the profession to the *galvanic current*, and he furthermore announced that in order to bring a muscle to complete contraction it is better to excite its motor nerves than to allow the current to operate on the muscular substance itself. His second work, "*Galvano-Therapie der Nerven- und Muskel-Krankheiten,*" was published in 1858.

Remak became the founder of a school of electro-therapeutists in Germany, as Duchenne had been in France. Their systems, as has been said, differed in two important particulars. Both used *localized* electrization. Duchenne used the faradic current, making the applications to the muscles; Remak used the galvanic current, making the applications to the motor nerves.

Duchenne declared that the galvanic current was useless for the treatment of disease, while Remak contended that it was the only current that was of any value. Duchenne was unwilling to admit the reality of the discoveries of Remak, and Remak as emphatically rejected the conclusions of Duchenne. Both enforced their statements by the results of experiments, and both appealed to experience.

It is now well recognized by all electro-therapeutists that there was truth on both sides of this interesting controversy—that the galvanic and faradic currents are both of service in the diagnosis and treatment of disease, and that too in more than one mode of application. We now see that if Duchenne was too dogmatic, Remak was too extrava-

gant, but that both of them, by their experiments and labors, were of positive service to science, and made the way easier and safer for those who have since followed them in the department of localized electrization.

Remak, shortly before his death, published a work entitled "*Application du Courant constant au Traitement des Névroses*," Paris, 1865, which contained the leading ideas of his system, and has been the means of stimulating many other experimenters in this difficult department.

Remak did more than merely introduce the galvanic current to the profession—he discovered and recommended special applications of the current, and suggested the theory of its catalytic action. He was the first to scientifically investigate localized galvanization of the cervical sympathetic, of the brain and spinal cord, and thereby greatly widened the sphere of electro-therapeutics. Although at first his theories were scouted, and his statements discredited, yet since his death they have, in the main, been strikingly confirmed, and are now regarded as accepted facts in science.

Even during this last era, franklinic electricity has been by no means laid aside. In 1847, Dr. Golding Bird published very remarkable results obtained in the treatment of amenorrhœa by static electricity, in Guy's Hospital. He made use of a Leyden jar. Franklinic electricity has been successfully used by Drs. Gull and Clement. It has, for a number of years, been successfully employed by Dr. Radcliffe and others, in the London Hospital for the Paralyzed and Epileptic. Quite recently Prof. Schwanda, of Vienna, has reported suggestive results from franklinic electricity generated by Holtz's electrophorus machine. Dr. Arthius, of Paris, has recently published a work on the subject; this has been translated by Dr. Leveridge, of Chicago.

Within the past fifteen years localized faradization and galvanization has been developed and improved in France, in Germany, in England and America, by a number of able and laborious men of science. Among the voluminous authors in this department may be mentioned the names of Meyer,\* Becquerel,† Baierlacher,‡ Althaus,§ Tripier,||

\* Die Electricität in ihrer Anwendung auf praktische Medicin. Berlin, 1854 and 1868. Translated by Dr. Hammond.

† Traité des applications de l'électricité à la Thérapeutique. Paris, 1857.

‡ Die Inductions-Electricität in physiologisch-therapeutischer Beziehung. Nürnberg, 1857.

§ Treatise on Medical Electricity. London, 1859. Latest edition, 1873. Galvanism in Paralysis, Neuralgia, etc., 1866.

|| Manuel d'Electrothérapie. Paris, 1861.



Rosenthal,\* Frommhold,† Ziemssen,‡ Garratt,§ Benedikt,|| Brenner,¶ Cyon.\*\*

*History of General Faradization.*—In general faradization the aim is to bring the whole body under the influence of the faradic current, so far as is possible, by external application.

The origin of general faradization, like that of localized, is somewhat uncertain, since it is difficult to determine how long it was used by the laity before we formally introduced it to the profession. It is certain that both methods have been in popular, and, to a certain extent, in professional use in America, from a period not long subsequent to the popularization of the discovery of induction, certainly a long time before they were introduced to the profession. One of the first—and probably the very first—to employ a form of general faradization was William Miller, of New York, who began the empirical use of this system of treatment in 1843. Since that time some form of general faradization has been employed by Sherwood, of New York; Dr. W. Deming, of Portland; Drs. Garratt, Cross, and Guthrie, of Boston; Dr. Wells, of Rochester, N. Y.; Drs. Page and Channing, and by a very large number, both in the profession and out of it, of whose names and special methods but little is known, since they have taken but little pains to establish the treatment on a scientific basis, or to introduce it to the attention of the profession. Many of these practitioners combined localized with general faradization, and some, perhaps the majority, employed the latter exclusively, though with little definiteness or precision. Although, as has been said, some of these early experimenters were educated physicians, the majority were ignorant not only of medicine, but of every other department, and not a few, unfortunately, were as unprincipled as they were ignorant.

Although many of these experimenters were laymen, although they had no part nor lot in the realm of science, and although many of them were as devoid of conscience as of intellect, yet we should none the less eagerly seek for and accept whatever of truth they may have stum

\* Die Electrotherapie, ihre Begründung und Anwendung in der Medizin. Wien, 1865. Latest edition, 1873.

† Electrotherapie mit besonderer Rücksicht auf Nerven-Krankheiten; vom praktischen Standpunkte skizzirt. Pesth, 1865.

‡ Die Electricität in der Medicin. Berlin, 1866. Latest edition, 1872.

§ Medical Electricity. Philadelphia, 1866.

|| Electrothérapie. Wien, 1868. Second edition, 1874.

¶ Untersuchungen und Beobachtungen auf dem Gebiete der Electrotherapie Leipzig, 1868 und 1869.

\*\* Principes d'Electrothérapie. Paris, 1873.

bled upon or discovered. In the history of therapeutics it has often been the fortune of the ignorant and the lowly to hit by chance on some great fact for which the wisdom of the ages has sought in vain. Says Dr. Stillé, "Nearly every medicine has become a popular remedy before being adopted or even tried by physicians ;"\* and according to Pereira, nux vomica is one of the few remedies the discovery of which is not the effect of mere chance.†

Impartial history must, we think, record that, before Duchenne and Remak were known on either side of the Atlantic, before our more recent electro-therapeutists had commenced their professional labors or studies, there were in this land not a few empirics who, by some form of general or localized faradization, or both combined, or by methods various and inconsistent, and in spite of their own ignorance or vice, were achieving successes in the treatment of disease which, in certain features, even the most advanced physicians of our day have not yet surpassed. If they did not belong to the chosen ranks of the profession, it is none the less true that the results which they secured were oftentimes such as the ablest leaders in science might well have envied. If their methods were empirical, their empiricism was often justified by its success. If their nomenclature was imperfect and confused, and their diagnosis erroneous, yet their confusion and errors were not a little redeemed by the skill with which they met emergencies when the therapist was far more needed than the pathologist or the diagnostician. *The great defect of these empirics was not in their results, which oftentimes were truly remarkable, but in the fact that their general ignorance, and especially their ignorance of medicine, rendered it impossible for them to discriminate in their cases or their methods, or to intelligently communicate their experience to others, or in any way to make it of permanent value to science.* They treated all cases about alike, without reference to the pathological condition, and in spite of all their successes frequently failed where, with better knowledge, they might have succeeded.

In Europe, so far as we can ascertain from the published writings on the subject, or from our own personal observation, the method of *general faradization*, as described in this work, has not been used or recommended, at least by men of science. In 1852, Beckensteinert

\* Therapeutics, vol. i., p. 31. The same author states that "by far the greater number [of medicines] were first employed in countries which were and are now in a state of scientific ignorance."

† Materia Medica, vol. ii., p. 336. Hydrate of Chloral may now be added to this list.

‡ Etudes sur l'Electricité. Paris, 1859.

suggested the idea of "animalizing" static electricity by passing it through the body of the operator, and making passes over or near the patient.

In 1857, M. Dropsy\* de Cracow published a new method of faradization, the *modus operandi* of which consisted in connecting an electrode by two branches on the top of the head and the epigastrium, while the other electrode was connected by four branches with the hands and feet. At each sitting the poles were reversed. In 1858, Seiler† proposed to cure consumption and many other obstinate and incurable diseases by passing a faradic current through two electrodes near to but not over the body of the patient.

In 1863, Gubler‡ suggested the treatment of conditions of debility by placing both hands and feet in separate basins containing salt water, and passing a faradic current through the body.

Our own attention was called to the subject of general faradization in 1866, and in that and the following year we introduced it to the profession, describing in a general way its powerful tonic effects and *modus operandi*.

(*The Medical Use of Electricity, with special reference to general electrization as a tonic, &c.* Beard and Rockwell, New York, 1867.)

The name *general electrization*, as descriptive of this method of treatment, was first employed by us and in the writings to which we have referred. In the present edition of this treatise we restrict the terms to *general faradization*, for the reason that our method of *central galvanization*, to be hereafter described, has to a considerable extent taken the place of *general galvanization*.

Our own claims in regard to general faradization are :

1st. To have studied the method as practised by the laity, and to have improved it, reduced it to a system, and given it a scientific basis, and to have shown its relations to other methods of using electricity—in short, to have done for this method what Duchenne did for localized faradization.

2d. To have interpreted its special and general effects, giving it a name, pointing out the true rationale of the method, and the indications for its use.

3d. To have first called the attention of the profession to this method, enforcing our views by the results of personal experiments.

\* Electrothérapie en application médicale pratique de l'électricité basée sur de nouveaux procédés. Paris, 1857, in 8vo.

† Galvanisation par influence. Paris, 1858.

‡ De l'Electrization générale. Bulletin de Thérapeutique, Dec., 1863.

4th. To have discovered in our experiments with this method, that electrization was a tonic of great and varied efficacy, and therefore indicated in a large range of conditions of debility, and to have forced this fact on the professional mind until it has become widely accepted, and has become the basis for the use of electricity in the treatment of medical diseases.

The length of time required to make a thorough application of general faradization, and the amount of practice necessary to acquire skill and facility in its employment, have interfered somewhat with its popularization among specialists in electro-therapeutics; but in spite of these difficulties the method is now used with the highest success by hundreds of physicians, specialists and general practitioners, &c., and its popularity is very rapidly increasing.

In Germany the method has been from the first received, in part through the careful résumé of Prof. Erb, of Heidelberg, with greater interest and appreciation and with more favorable consideration than in any other country, excepting perhaps the United States. Dr. R. Väter, of the University of Prague, in his preface to the German translation of the first edition of this work, has warmly recommended the method, basing his recommendation on his own personal experience; and more recently, Benedict of Vienna, in the latest edition of his work, has given the method intelligent and appreciative consideration.

*History of Central Galvanization.*—The method of central galvanization, as has been described in our published papers (Electricity and the Sphygmograph, N. Y. *Medical Record*, December 15, 1871; also, Recent Researches in Electro-Therapeutics, October, 1872, by Dr. Beard; Central Galvanization, N. Y. *Med. Journal*, May, 1872, by Dr. Rockwell), consisted in *placing the negative pole at the epigastrium, while the positive was applied over certain portions of the head, over the sympathetic and pneumogastric in the neck, and down the whole length of the spine from the first to the last vertebra.* At that time we had used the method with the highest success, in hysteria, insanity, neurasthenia, gastralgia, dyspepsia, and certain diseases of the skin, and since that time this method has been extended to a wide variety of affections. In some diseases it has supplemented, in others it has supplanted, general faradization and galvanization of the cervical sympathetic.

The full method of central galvanization, as it will be described in this edition of the present treatise, was not stumbled upon by accident, but is the result of a long period of experimenting. When we began to use the galvanic current, we sometimes treated gastralgia and dyspep

sia by placing one pole, usually the negative, in the epigastric region, and the positive on the nape of the neck at about the sixth cervical vertebra. Gradually we extended the domain of the application so as to include the mastoid fossa and the anterior border of the sterno-cleido-mastoid muscle, down to the sternum on both sides. Afterwards we resolved to apply the positive electrode to the forehead, still keeping the negative on the epigastrium.

Influenced by the fact of observation, that the top of the head between the ears was frequently tender and painful in hysteria and neurasthenia, in both sexes, it occurred to us that this might be a good place to plant the electrode so as to affect the brain. Another consideration of practical moment was, that this place in both sexes is quite accessible, even with the present methods of arranging the hair. Looking at the subject from the standpoint of anatomy, physiology, and pathology, also, it was sufficiently clear that in galvanizing the brain, the object should be, not so much to affect the anterior lobes as the base and posterior portion, where originates the great cranial nerves. We soon found by clinical observation, that little dizziness was caused when the electrode was placed in this position, and that a stable current of a number of cells could be borne without unpleasantness, and that oftentimes a peculiar sensation was experienced, very different from the stinging and pricking sensations that are felt when the electrode is placed on the forehead. Last of all we extended the application, so as to include the whole length of the spinal column, passing the electrode beneath the clothes of the patient, loosened and pulled up for that purpose. Since the first publication of this method of central galvanization, we have modified it by changing the position of the negative pole, up and down the breast and abdomen, so as to avoid over-irritating the stomach.

Some of the processes of central galvanization had been used by other physicians, long before we worked up the complete method as he described. Dr. Althaus writes us, that several years since he had employed the first step in the process—one pole at the epigastrium and the other at the back of the neck, but becoming alarmed by unpleasant symptoms, had abandoned it; and Dr. Meredith Clymer, of this city, informs us that during the past three or four years he has independently used the processes of central galvanization with tonic results that have been most pleasing.

The ill-fortune of Dr. Althaus was due, we suspect, to the fact that he used powerful or interrupted currents—a mistake that we repeatedly made during our earlier experiments, a mistake that is frequently made by those beginning any new method of electrization.



## CHAPTER II.

### GENERAL THERAPEUTICAL ACTION OF ELECTRICITY.

#### *Electricity in its Medical Relations is a Stimulating Sedative Tonic.*—

The cause of medical electricity has been, and still is, greatly retarded by vague and incorrect notions of the position of electricity in the materia medica. It has been classed as a stimulant, and up to the time when we began to write on the subject, in 1866, nearly all the writers on the subject had assumed without question or discussion that the stimulating action was the main if not the only action of electricity. The idea that it was also a tonic was not even discussed. The first formal presentation of the use of electricity by the method of general faradization appeared in a paper by Dr. Rockwell, based on considerable experience and many experiments, and entitled "Electricity in the Treatment of Rheumatic Affections," and published in the *Medical Record* in 1866. In this and subsequent papers by both the authors of this treatise, the tonic effects of electricity were fully demonstrated. Those few in the profession who used electricity at all had gone no further than Duchenne, and supposed that when they had used this agent to kick up palsied muscles, they had exhausted its therapeutic indications. In obedience to the same narrow and exclusive dogma, electricity was supposed to be exclusively contraindicated in febrile and inflammatory affections, and was supposed to be of value only in a very limited range of subacute and chronic diseases. The acceptance of the view that electricity is a tonic has wrought a revolution in electro-therapeutics. An agent which was formerly used mainly if not exclusively in paralysis and rheumatism, is now used, and with far more brilliant success, in hysteria and affections allied to it, in insanity, anemia, neurasthenia, in nervous dyspepsia, neuralgia, chorea, in the convalescence from fevers, and all forms of pain and debility whatsoever.

It is necessary to state, at the outset, that in classing electricity as a *stimulating sedative tonic*, we use the words in the sense in which they are ordinarily understood and employed when applied to other remedies and systems of treatment, and without any reference to the mere

verbal distinctions that may be or have been made in the classification of *materia medica*.

*Stimulants* are usually understood to be those agents which *quickly excite* the system, and *temporarily* arouse its activity. They are like the goad, which forces the exhausted beast to draw the burden, but does nothing to increase his strength; or like the blast of the furnace, which increases the combustion, but adds no fuel. We do not accept this definition, but would prefer to regard stimulants as those agents that correct, intensify or economize the forces of the system.

Sedatives may be severally defined as those agents that allay irritability and pain and induce natural repose.

*Tonics* are ordinarily understood to be those agents which gradually *improve nutrition*, restore enfeebled functions, invigorate the system, and permanently increase its capacity for labor.

It is because electrization is capable of producing at once the effects which are ascribed to all these classes of agents, that we have defined it a stimulating sedative tonic.

These various effects are not always mathematically distinct, but run into each other. The stimulant effect may at once lead to sedation, and the permanent improvement to nutrition follows after a long time, and is in part a result of both stimulation and sedation.

Of these three orders of effects, *stimulation*, *sedation* and *improvement in nutrition*, stimulation is the one that is of the least importance, and yet it is the one that first strikes the observation, and the one which until very recently has been regarded as the exclusive test for the use of electricity in medicine. If electricity were merely a stimulant it would scarcely pay to use it in the treatment of disease, for its range would be so narrow, and the result of its use even in that narrow range so temporary and unsatisfactory, that physicians would not find it to their advantage to spend time and labor in making the applications.

The ill success of all previous attempts to popularize electro-therapeutics is to be explained in part by the fact that those who experimented with it looked upon it as a simple stimulant and nothing more, and recommended it accordingly. If it depended on its stimulating action only, the cause of electro-therapeutics would have little vitality. The reason why electricity is now growing in popularity in the profession is because it is found to relieve all forms of pain, and to add tone to the system and improve nutrition after ordinary sedatives or tonics have failed.

*Tonic Effects of Electricity best elicited by General Faradization and Central Galvanization.*—Reasoning from analogy, as well as from experi-



ence, it would seem that the full effects of electricity on the human body could only be obtained by making the applications *all over the person and on the central nervous system in such a way as to affect the whole system*. The influence of any drug or remedial agent on the constitution can only be ascertained by bringing the *whole system* under that influence. A man who habitually washes one of his fingers in cold water appreciates the tonic effects of the cold only in that finger; but a man who habitually takes a shower-bath, or plunges into a tub of cold water, realizes powerful tonic effects on his entire system. If a man daily exposes one arm to the sunlight, while the rest of the body is enclosed in a dark cell, he receives direct tonic effects only in the exposed member; but he who walks forth and exposes his whole person to the solar rays will in time experience the full tonic effect of sunlight on his system. If one hand or one foot is vigorously and regularly exercised, the muscles of that limb exhibit the tonic effects of the exercise, and increase in hardness and perhaps in size; but if all the portions of the body are vigorously and regularly exercised, all the principal muscles will increase in firmness and perhaps in size, and tonic effects will be appreciated by the entire system.

Just so with all other tonic remedies and influences. If quinine, strychnine, iron, arsenic, oil, etc., could be localized in a single limb, only that limb would be directly influenced by them. Their tonic effect is only obtained by administering them in such a way that they will penetrate every portion of the body.

Electricity is no exception to this law. In order to ascertain its full effects on the system at large, and to determine its position among remedies, the applications must be made in such a way that the whole system shall, so far as possible, be directly or indirectly brought under its influence. This is best accomplished by the methods of *general faradization* and *central galvanization* that are hereafter to be explained in detail.

In making a detailed comparison, therefore, between the effects of electrization and the effects of recognized tonics—quinine, iron, strychnine, physical exercise, sunlight, cold bathing, etc.—it is logically necessary that the applications should be so given that the whole body should be brought under the direct influence of the current, just as it is brought under the influence of other recognized tonics as ordinarily administered.

The immediate effects of an application of general faradization and central galvanization are often a feeling of enlivenment and exhilaration, drowsiness, temporary relief of pain, and increased warmth of the body.

The same effects are notably observed after the shower-bath, a tumble in the surf, a brisk walk in the open air, or from the administration of alcohol.

Like other stimulating tonics, general faradization and central galvanization, when given in an overdose, or in too great strength for the constitution of the patient or the condition of the system at the time, may be followed by secondary or reactive effects that are both disagreeable and positively alarming. The second or third day after an injudicious application, the patient, especially at the outset of treatment, may experience soreness in the muscles, an indefinable feeling of nervous exhaustion, irregularity of pulse, and sometimes exacerbation of special symptoms. It is well known that severe physical exercise will produce all these unpleasant secondary effects, especially in patients who are feeble and unaccustomed to muscular exertion. A cold bath, either in the surf or at home, that is too prolonged may give rise to all these symptoms the night or day following. Unpleasant effects may secondarily follow an overdose of our ordinary stimulants, as alcohol, or from internal tonics, as iron, quinine, strychnine.

The permanent effects of general faradization and central galvanization are as closely analogous to those which come from other tonic remedies and systems of treatment as are the immediate and secondary effects.

The very marked permanent effect of general faradization and central galvanization is improvement in the sleep. Physical exercise—walking, boating, gymnastics, bowling—cold bathing, and the ordinary internal tonics do the same, though not so markedly and with far less uniformity.

General faradization and central galvanization also permanently improve the appetite and digestive capacity, and regulate the bowels. Improvement in the various operations of digestion is one of the most uniform effects of our ordinary tonics, and it is for that purpose, more perhaps than for any other, that they are employed.

Like other tonics, general faradization and central galvanization equalize the circulation. This effect, when it *immediately* follows an application, is nearly the *temporary* excitement, similar to what follows a rapid walk, or gymnastics, or alcoholic stimulants, and soon passes away. But when it becomes a permanent condition—when the patient feels less annoyance from chilliness and cold extremities—it is a resultant of the improvement in nutrition.

Like other tonic measures—gymnastics, active games, and outdoor amusements, etc., etc.—general faradization and central galvanization

cause the muscles to develop in size and hardness, and sometimes, though by no means uniformly, produce important and rapid increase in the weight of the body, the result of the improvement in nutrition. Increase in weight is familiarly observed after a trip of pleasure, a vacation in the country, a voyage by sea, and very frequently indeed from the use of cod-liver oil and strychnine. General faradization sometimes causes the patient to increase in weight from the very outset of the treatment, and to an extent that is most surprising.

Like other tonics, general electrization, faradization and central galvanization, in their ultimate effects, increase the disposition and the capacity for labor of the brain or of the muscles. This is indeed the chief end to which all tonic treatment is directed, inasmuch as diminished capacity for labor is perhaps the condition for which tonics are most frequently advised, and it does not usually increase the capacity for toil until it has first improved the sleep, the appetite, the digestion. The same is true of many other, if not all, tonic remedies.

Experience shows that general faradization and central galvanization are usually contraindicated in those diseases and for those temperaments that will not bear any of the internal tonics. We find almost invariably that they must be used most cautiously, and meet with their worst failures in cases where quinine, strychnine, iron and stimulants have proved to be injurious.

Whatever difference of opinion there may be concerning the rationale of electrization, or whatever dispute there may be concerning the use and the meaning of the words stimulant, sedative, and tonic, the majority of advanced practical electro-therapeutists must substantially endorse the emphatic words of Prof. Niemeyer: "*In the constant current we have a means more powerful than any other of modifying the nutritive conditions of parts that are deeply situated.*" \*

*Rationale of Electrization.*—The stimulating, the sedative, and the tonic effects of electrization are resultants of the various and diverse action of the currents on the tissues. These effects have been defined as *mechanical*, *physical*, *catalytic* (increase of circulation and absorption), *electrotonic* (modification of nerve), *electrolytic* (electro-chemical decomposition), and *chemical*. The mechanical effects are more markedly observed from the faradic current, the other effects from the galvanic. These terms, considered as explanations of the action of electrization, are, it must be admitted, quite unsatisfactory, since they are incapable

\* *Text-Book of Practical Medicine*; Translation of Drs. Humphreys and Hackley, vol. ii., p. 290.

of exact and complete definition, and must, to a certain extent, include each other. It is safe to say that we know as much of the *rationale* of electrization as of most of our internal remedies. (See chapter on the subject in Electro-Physiology.)

*Is Electricity Transformed into Nerve Force?*—Nearly all of the earlier and very many of the latter experimenters in electro-therapeutics assumed without argument, that electricity was identical with the nerve force, or, at least, that it was directly transformed into it. Although the weight of evidence is at present decidedly against the theory of the identity of those forces (see Experiments of Helmholtz), yet the assumption that they are identical or can be directly transformed into each other, still lingers. The taking phrase, "Electricity is Life," is constantly used as the war-cry of rival instrument makers, and as the motto of travelling charlatans, on the street corners and at country fairs. Whatever future science may unfold, we are now forced to say that not only is there no evidence that electricity is identical with life, but also that the theory that electricity, when applied to the body, is ever directly transformed into nerve force has few if any facts or arguments in its favor. That the body can be charged with electricity, and that the normal electricity of the body can be changed in character is clear enough; but it does not follow that such changing of electrical condition has any direct influence on the quantity or quality of the nervous force. Whether galvanic or faradic electricity charge the body to any extent in passing through it may rightly be doubted; if they leave more electricity in the body than they found in it, it must be by virtue of the direct influence of the current over the nutrition. Electricity is no more life than light and heat are life. Like light and heat it may sustain life, not by direct transformation, but indirectly through its influence over nutrition. When the light of the sun falls on a plant or animal, when artificial heat is applied to a cold and paralyzed limb, growth is stimulated and nutrition improved, but not, so far as can yet be demonstrated, by any direct transformation of light or heat into nervous force. Similarly, also, we have no sufficient evidence as yet that the varied and marvellous improvement in nutrition that follows electrization is the result of anything more than the indirect improvement in nervous force, which is a part and result of the general improvement in nutrition.

In the time and manner of their development the tonic effects of general faradization and central galvanization resemble those of other tonics in these *two* particulars.

1. *They are Developed Slowly.*—This slowness of development marks

a radical distinction between tonics and mere stimulants. The agreeable stimulating effects which immediately follow an application of general faradization and central galvanization, just as they follow the use of gymnastics, walking, active games, etc., soon pass off or merge into the permanent or tonic effects that come more or less slowly, and after repeated treatment.

2. *They are often Developed long after the Treatment is Abandoned.*—Weeks and months after a patient has taken a course of general treatment by general and central electrization he may continue to improve in his general condition, even though very little progress may have been made while the applications were being received. Just so the tonic effects of a trip by land, of a sea voyage, of our ordinary summer vacations, are sometimes not appreciated until after we have returned home, and are again fully at work.

*Why were not the Tonic Effects of Electricity sooner Discovered?*—The inquiry now very naturally arises, why it is that the important fundamental fact—that electrization is a powerful means of improving nutrition, and capable of producing effects on the constitution similar to those which are familiarly obtained from the tonics in every-day use—has escaped the observation of the very able writers who in different lands have devoted themselves to electro-therapeutics, until we called attention to them.

The inquiry is thus answered :—

1. Because most of the recent scientific observers whose writings are authorities in electro-therapeutics have used electricity locally, in some form of "*localized electrization.*"

For obvious reasons, that have already been presented, *localized electrization* must produce chiefly local effects, which although they are *tonic* in their character, so far as they go, and reveal themselves by marked improvement in the local nutrition, would not ordinarily suggest the powerful constitutional tonic powers of which electrization is capable when applied all over the body, any more than the feeble effects of washing the hands, the face, or the feet, or any single member or organ, would suggest or give any intimation of the well-known constitutional effects of surf-bathing or the shower-bath.

*Indirect* constitutional effects result from localized electrization of the central nervous system, and especially from galvanization of the brain, spine and cervical sympathetic, although, as will be seen, they are not as marked as those which follow general faradization and central galvanization.

It is a very interesting and significant fact, however, that since the

introduction into medical practice of the methods of localizing the galvanic current in the nervous centres first suggested by Remak, electro-therapeutists have achieved success in a variety of diseases associated with debility and impaired nutrition, where before electrical treatment was supposed not to be indicated, at least by those who confined themselves to localized electrization.\* A suggestive fact relating to this subject is that Gubler, who is one of the very few European writers who had used faradization in such a way as to directly affect the whole system, also remarked tonic effects in conditions of debility, even from his very awkward and imperfect method.†

2. Because the immediate effects of electrization are so markedly *stimulating* as to suggest the idea that it is simply and *only* a stimulant or irritant. In some of the cases for which localized electrization are used the stimulant are the effects which are chiefly desired. But, as has already been shown, many of our ordinary tonics are primarily stimulating, and so much so that they have been classed as *stimulating tonics*.

There is little question that if many tonics in ordinary use, had been used only locally, as electricity has been used, they might have been regarded merely as stimulants.

3. Because until quite recently most of the recognized authorities and writers on electro-therapeutics of modern days have not used electricity in those diseases and morbid conditions where tonics, *par excellence*, were demanded. They have used the agent mainly with a view to stimulating effects, and in some form of localized electrization. On this principle they have treated paralysis, rheumatism, neuralgia, etc. As we shall demonstrate hereafter, besides those diseases in which the efficacy of localized electrization is fully established, the morbid conditions and symptoms for which electrization is most rapidly and permanently successful, are precisely those in which we use our ordinary tonics—such as dyspepsia, nervous exhaustion, insomnia, hypochondriasis, hysteria, general neuralgia, chorea, spinal irritation, and some forms of paralysis dependent on or associated with general debility.

Furthermore, in prosecuting this inquiry we must not overlook two important historical facts:—

1. In the latter part of the last and early part of the present

\* *Vide* the writings of Remak, Meyer, Benedikt, Niemeyer.

† De l'Electrization générale considérée comme agent tonique et stimulant diffusible. *Bulletin de Thérapeutique*, Décembre, 1863. (For description of his method, see p. 246.)

century franklinic electricity and the current of the voltaic pile were used for a variety of diseases for which we now use tonics, and oftentimes with some success. But the agent was used mostly empirically, without any definite idea of its nature or the *rationale* of its operation. Partly on account of the inconstancy and uncertainty of the voltaic pile, and partly on account of the many failures that were necessarily inevitable with such poor apparatus and desultory experience, partly also as a reaction from the extravagant hopes and promises of the earlier experimenters, this system of treatment soon fell into disrepute.

2. Tonic effects have been obtained from various methods of employing electricity by non-professional men—charlatans and outsiders—in the United States at least, for many years, although very few of them have known or suspected the nature of the agent they dealt with, or of the diseases they have treated.

## CHAPTER III.

### GENERAL SUGGESTIONS IN REGARD TO THE USE OF ELECTRICITY AS A THERAPEUTIC AGENT.

BEFORE describing in detail the different methods of using electricity, it may be well to offer some suggestions of a general character that will apply to all the different methods of electrization, localized and general, with the faradic and with the galvanic currents. It is of the first importance that those who are beginning to study and practice electro-therapeutics should have correct notions not only of the general therapeutical action of electricity—the principle on which it is used—but, also, of the general laws of its application. Such knowledge fits one to intelligently study the special methods of application, and the treatment of the various diseases. A want of this knowledge is a constant hindrance, and not unfrequently utterly discourages the beginner in this science.

*General Indications for the Medical use of Electricity.*—An error that appears prominently in nearly all the works on medical electricity, and one that seriously interferes with the progress of *healthy* and *philosophic* electro-therapeutics, is the habit of treating the name of the disease rather than the *condition of the system* of which the symptoms are the result and expression. Men ask whether electricity is good for this disease or that disease without any well-defined idea of the position that this powerful agent occupies in the armory of therapeutics. It should be understood that electricity is a powerful *stimulating sedative tonic*, and as such is indicated in any subacute or chronic disease, where stimulating, sedative or tonic effects are indicated, and without reference to the name of the disease by which the condition expresses itself. With this general principle before us, we cease to wonder that electricity is used and recommended in such a wide variety of diseases, many of them of an apparently opposite character, and we see the injustice of that criticism which condemns electricity because it is good for so many different affections. Just as quinine, which is not a specific for any



disease—unless it be chills and fever—is yet used freely as a tonic in an indefinite number of diseases where tonic effects are required, so electricity, which is not a specific for any one disease, is yet used with good results in any number of diseases where local or general nutrition is impaired and needs to be improved. The indications for the use of electricity are wider than the indications for the use of quinine, for the threefold reason that it has a powerful sedative action which quinine, or indeed any other single tonic remedy does not have ; that its stimulant and tonic effects are more decided, and that its effects, sedative, stimulating or tonic, can be confined mainly to certain organs, nerves or muscles, or be distributed through the whole body, as may be thought necessary. When the propriety of using electricity in any medical case is discussed, the first questions to be answered are :

1. Is there any pain to be relieved ?

2. Is there any need and chance for improvement in local or general nutrition ?

If these questions can be answered in the affirmative, then electricity in some mode of application may be administered. The result of the treatment will depend on the skill with which it is conducted, on the nature of the lesion and length of time that it has existed, and on the agreement or disagreement of the temperament of the patient with electricity.

*Stage of Disease when Electrical Treatment is Indicated.*—Electricity is indicated mainly for subacute and chronic diseases ; at least the best results that come from the use of this remedy have thus far not been obtained in the acute stages of disease. And yet there is no question that in the acute stages of rheumatism faradization is of value, and there is reason to believe that future experiments will show that relief of pain, of sleeplessness, and of general nervousness—with perhaps permanent benefit—may be obtained in the active stages of febrile and inflammatory affections. The chief theoretical objection to the employment of electricity in acute diseases is the fact that the tonic effects of electrical treatment require so much time that any disease that runs but a limited period will not be able to appreciate them. This objection does not, however, apply to the stimulating or sedative effects ; these can be felt instantaneously or within a few hours after an application. Electricity is certainly one of the most potent of sedatives, and in very many acute affections sedatives are constantly indicated.

The old notion that electricity was merely a stimulant aided in forming in the professional mind another very gross error, that in active inflammations electricity is contra-indicated. Experience proves every day

that the sedative effects of electricity are exceedingly grateful in even the acute stages of sprains and diseased joints.

The dogma that in hemiplegia from cerebral effusion it is better to wait for several months until all the active irritation has subsided, before beginning electrical treatment—which error is yet maintained by many of the ablest writers on medical electricity—took its origin in the erroneous conception of the position of electricity in the *materia medica*.

It is difficult to conceive of any actively inflamed or febrile state, where electricity, in the hands of one who knows how to use without abusing it, may not be used without injury even if it does no good.

*Differential Action of the Poles, and of the Ascending and Descending Currents.*—This is a subject on which much has been thought and written, and concerning which opinions have been expressed with an absoluteness not justified by experience. Almost the first question that the beginner in electro-therapeutics asks, is, “Which pole shall I use?” as though that were the fundamental problem to be solved. Another question that is put in almost the same breath is, “Shall the current be ascending or descending?”

These queries seem to the novice to be of supereminent importance, and he is annoyed that his instructor or text-book does not lay down such positive rules on the subject as to set his doubts at rest forever. In after years, when he shall have had much experience, he will learn these two facts: *First*, that the question, which pole or which direction of the current to use in any given case, is one of various complexity, and cannot always be solved by a dictum. *Secondly*, he will learn that the practical therapeutical difference in the action of the pole or of the ascending and descending currents, is much less demonstrable than he supposed, and that the special directions for each disease are not at hand.

The difference of the physiological action of the poles of the galvanic current, when applied to the body, is, as we have shown under electrophysiology, of a radical character. It has specially been shown that the *anelectrotonic* region at the positive pole is in a condition of diminished, while the *catelectrotonic* region near the negative pole is in a condition of increased irritability. Moreover, it is easy of demonstration that the negative pole of both currents is more painful than the positive, and this fact, as we have seen, enables us to distinguish the poles in cases of doubt, or when we do not understand the construction of the battery. Still further we have seen that on the nerves of special senses—notably on the optic and auditory nerves—the poles have a differential action of a specific and demonstrable character.

When now we leave physiology and enter into the complex realm of therapeutics, we find that it is usually better that irritable parts of the surface of the body should be treated mainly by the positive pole. This relative position of the electrodes is not usually departed from in general faradization and central galvanization, for the reason that the majority of cases that require these methods of treatment are abnormally irritable.

The negative pole, being more irritating than the positive, is indicated when it is desired to cause contraction in a paralyzed muscle, and the difference between the poles in producing muscular contraction is chiefly a difference of *degree* only, since both poles cause contraction when placed on the body of a muscle or over its motor point, but with the same strength of current a more vigorous contraction will be produced by the negative than by the positive pole.

In regard to the differential action of the ascending and descending currents there has been an almost infinite amount of shallow observation and impulsive writing; for how the differential therapeutical or differential physiological action of the ascending and descending currents is to be rightly *discriminated from the action of the poles* we cannot well understand.

The object of applying electricity to the body in disease is to *improve nutrition*, and nutrition is a process of infinite complexity; indeed, the most complex and most mysterious of all the wondrous processes of nature. He who solves it will become immortal, both as the greatest scientist and the greatest theologian of history, leaving Newton and Calvin far behind. The relief of pain, the reduction of tumors, the increase in size of muscles—all these everyday results of electrization are signs of improvement in nutrition, and it is impossible to exhaustively explain them by anything we now know of electro-physiology. Any man who attempts to base all his electro-therapeutical procedures on the laws of electrotonos will find himself involved in complications that have no end.

The one practical rule in regard to the poles, which we have arrived at, is that the *positive pole is the less irritating*. In accordance with this rule we place the negative pole at the feet or coccyx in general faradization, and at the pit of the stomach in central galvanization, so that the head, neck, and spine, and other sensitive parts affected may be under the influence of the positive pole.

That differential effects—physiological and therapeutical—may arise from a difference of current direction is not at all improbable—certainly no one can well prove the negative—but we see no way of

demonstrating such differential effect. In every attempt that we make the differential *polar* effect comes in to complicate, and in our judgment, to override any differential effect there may be in current direction. Take the familiar experiment : an electrode in each hand ; in one arm the current will be ascending, in the other descending. If now one arm were differently affected from the other, have we any right to rush to the conclusion that such differential effect is due to the fact, that in one arm the current is ascending, in the other descending ? Is it not far more probable that such differential effect is due to the fact that the positive pole is in one hand and the negative in the other ? The differential effect of the poles can be demonstrated in various ways, and our knowledge of it influences our practice ; the differential effect of current direction, if it be not entirely a myth, is to say the least undemonstrated.

Take again, for illustration, the method of galvanizing the spine. If the negative pole be placed at the nape of the neck, and the positive at the lower end of the spine, the current is ascending, and if a certain effect is produced, or believed to be produced, such effect is attributed to the fact that the current is ascending. The upper part of the cord is under the influence of the negative pole, and the lower part of the cord is under the influence of the positive pole, and what evidence is there that there is any differential action of current direction aside from the differential polar action ?

Similar difficulties beset us when we place one pole, say the negative, on some indifferent point, as the feet, or thigh, and pass the positive up and down the spine. Have we any right to attribute the effect produced to the fact that the current is descending, when we know that the positive pole has a very different physical, physiological and therapeutic effect from the negative pole, without any regard to current direction, while we, as yet, do not know that the ascending current has a different effect from the descending current, without any regard to the differential polar effect. One thing is clear and indisputable, and that is that the differential effect of current direction, assuming that it exists, is largely overborne by the differential polar effect. This is true of both currents. A crucial experiment for determining the question of the differential action of the ascending and descending currents, would be to experiment on a piece of nerve in a physiological condition, all parts of which give the same response to electrical excitation, and are known to have the same function.

If such a nerve-piece could be supposed, and if the positive pole could be placed on the middle of it, and the negative pole at the peri-

pheral end, we should have a descending current ; the positive pole remaining at the middle and the negative transferred to the central end of the nerve, would give the ascending current. If now the effect after these procedures should be different, the strength of current, pressure employed, and time of stimulation being the same, and if the effect of previous stimulation could be eliminated before the second part of the experiment is made, we should have a conclusive demonstration of the differential physiological effect of the current direction. But such an experiment is ideal, and the complications are too great for science at present to make it actual. In all physiological experiments of this kind differential polar effect complicates, if it does not neutralize, the differential effect of current direction.

In therapeutics, the complications of the subject are all the greater, because all the statements that have been and are made in regard to the advantages or disadvantages of the ascending or descending current in this or that direction are of little worth.

The practical rules on this subject to which experience, enlightened and fortified by physics, physiology, and pathology, have led us, may be thus recapitulated.

1. The stimulating, sedative and tonic effects of electricity, faradic and galvanic, are obtained by either pole, or by both combined or in alternation, the difference in their therapeutical action being merely a difference of degree.

2. In cases where the sedative effects are more indicated than the stimulating effects, the positive pole is preferable to the negative, since it is less irritating, and with the uninterrupted galvanic current, produces catelectrotonos, or a condition of diminished irritability.

In the great majority of the nervous cases, where general faradization or central galvanization are used, sedation is more needed than stimulation ; hence the general rule to use the positive pole in these methods.

3. In cases where the stimulating effects are more indicated than the sedative effects, the negative pole is preferable to the positive, since it is more irritating, and with the galvanic current produces catelectrotonos, or increased irritability.

For those temperaments, now and then met with, that are exceedingly tolerant of electricity, who can bear it in any doses, however given, and for cases of local or general anæsthesia and paralysis of motion, whatever may be the pathological cause, stimulation is more needed than sedation ; hence it is an advantage in such cases to use the negative pole, and in some cases "voltaic alternatives," which are more irritating than either pole when used alone.

Inasmuch as we cannot tell the degree of electro-susceptivity in a patient until we have tested it, it is well always to begin general faradization and central galvanization with the positive pole. This rule is especially important in the United States, where the majority of our patients of both sexes are susceptible and nervous and require sedation more than stimulation.

*Both the Seat of the Disease and the Effects of the Disease to be Treated.*—The query whether in localized electrization we should direct the treatment mainly to the *seat of the disease*—the pathological *lesion*, or to the *seat of the prominent symptoms*—the *effects* of the lesion—has given rise to some discussion.

It sounds very practical to advise the treatment of the symptoms without regard to the seat of the lesion. It sounds very scientific to claim that the electricity should be confined to the exact seat of the disease. Now the wise physician is both scientific and practical, and keeping clearly before the mind this central thought, that the leading action of electricity is that of a stimulating tonic with a powerful sedative influence, we can readily discern the truth on this subject. Both the seat of the disease and the seat of the symptom should be treated, for in both there is need of improvement in nutrition. In this view common sense and experience accord. In hemiplegia, for a typical example, the lesion, the seat of the disease, is in the brain, while the leading symptom is in one-half of the body, which is paralyzed. The muscles of that side become atrophied, and the nerves become anæsthetic. To restrict the electrization to the brain, and to that side of it where the lesion is or is supposed to be, is so imposing and scientific in theory that electro-therapeutists of limited experience might advise this treatment exclusively. To purify the stream, first purify the fountain. Lay the axe at the root of the tree. All these analogies are beautiful, but they are fallacious. The symptoms of the disease will not disappear when the disease disappears. The effects remain after the clot is absorbed. In the larger number the half of the body is as much the seat of the disease as the brain; for the several parts of this human machinery are all members one of another. When one suffers all suffer. To confine the treatment to the paralyzed muscles is also irrational, although the purely peripheral treatment is far more successful than purely central. If we are to be exclusive and one-sided and theoretical in our treatment, it is better to exclusively treat what are called the symptoms or effects of the disease, and to neglect the brain altogether. But it is the part of the higher wisdom to use both methods—central and peripheral, to **attack the seat of the lesion and the seat of the symptom.**

The most satisfactory results in hemiplegia come from a combination of peripheral and central treatment. Similarly with diseases of the spinal cord, as congestion, sclerosis, resulting in paralysis of motion or sensation. Purely central treatment—galvanization of the spinal cord—is not sufficient; the symptom also, the paralysis, must be treated directly in the muscles and nerves where it is most prominent. In diseases of the spinal cord, treatment confined to the seat of the disease does more good than in diseases of the brain, for the reason that the cord is more accessible to the current, its surface being more exposed, as it were, throughout its entire length. But those who content themselves with treating diseases of the cord by simple galvanization, to the exclusion of peripheral treatment, make a grave mistake; they fail where they ought to succeed, and they succeed only in a small percentage when a large percentage was possible. Cases of ataxia, as well as of motor-paralysis need peripheral treatment with the moist sponge or wire brush, or both, as well as galvanization of the spine. On the same principle our method of central galvanization is sometimes more effective in diseases of the cord and brain than localized galvanization of these parts, as usually practised. In neuralgia also, where the seat of the disease is in the nerve-centres, the application should be made both to the tender and painful points, as well as over the root of the nerve, and a very good method of application is to place one pole over the origin of the painful nerve, as near as possible, and the other over the tender point and along the whole course of the nerve. Frequently neuralgia, as we shall see, yields to our method of central galvanization—where not only the painful and diseased parts, but also the whole central nervous system, whether healthy or not, is treated,—when it does not yield, at least as rapidly or as surely, to local applications either central or peripheral.

*Healthy parts may be benefited by Electrization.*—There is a kind of unconscious idea abroad among electro-therapeutists that in applying electricity to the body it is necessary to avoid acting on healthy parts, and that the direct effects of the current should, so far as possible, be confined to the part that is *supposed* to be in a diseased condition. This erroneous doctrine takes its origin, *first*, in the teaching of Duchenne and other advocates of localized electrization, and, *secondly*, in the narrow and incorrect ideas of the general physiological and therapeutical action of electricity.

Duchenne, by embodying the term “localized” in the title of his work, has done much to popularize in the profession the notion that in electrical applications the aim should be to concentrate the current on the

part where it is supposed to be needed, and to avoid affecting other parts.

The idea that electricity is a mere stimulus, and only valuable as a means of exciting paralyzed muscles or waking up dormant nerves, would very naturally lead to the adoption of the view that it should be used only in those parts that are in need of stimulation, and that healthy parts would be injured by it. The false ideas that have prevailed in regard to effect of stimuli, which we have elsewhere discussed, have tended to increase this absurd dread of applying electricity to healthy parts. A little common sense applied to this subject may perhaps help us to find the truth without great difficulty.

First of all, we must bear in mind always that the doctrine taught by the European writers, that electricity is a stimulus merely, is narrow and erroneous. Electricity, applied to the body, acts as a stimulating tonic with a powerful sedative influence. Then, again, stimulants are something more than mere goads or spurs; they correct and intensify the forces of the body, and may be useful and as necessary in conditions that we call healthy as in those that we call unhealthy. Stimulants tonics, and sedatives are called for every day, and are every day employed by nearly every member of the human race, young or old, sick or well.\*

Still further, pathology is not so much a special and separate condition as a degree of the normal condition of health. No one can tell just where physiology ends and pathology begins. Reasoning from all these considerations, it is clear not only that electricity need not be confined to diseased parts, but that the parts that we call healthy may be benefited by it just as truly as those that we believe to be unhealthy, and the benefit they receive may react favorably on the diseased parts, and thus aid the treatment.

These views are enforced by analogy. Very few of our stimulating tonic or sedative remedies are limited in their action to parts that are diseased. The medicines that we give by the mouth or by the syringe go whither they please, and if they sensibly affect some diseased organ, it is not because their action is confined to that organ, but because that organ, on account of its readier operation or of its disease, is more sensitive than other parts to the influence of remedies. Alcohol or opium go to the brain, lead affects the exterior muscles of the forearm, and the influence of chlorate of potash is quickly felt in the mucous membrane

\* This subject is discussed in detail in Dr. Beard's work on "Stimulants and Narcotics."



of the mouth ; but none of these remedies restrict themselves to the parts that are the most perceptibly affected by them.

Indeed, the fact that our most valued medicines are used for such a variety of local and general affections shows that their effects are not confined to separate parts of the body to the extent that has been supposed.

Electricity can be localized, in cases where it is desirable to do so, better than almost any other remedy, and yet the most careful and successful localization of the current is more or less imperfect. The reflex effect of electrization that always complicates the direct effects, and which are sometimes of more value than the direct effects, cannot be avoided. Then, again, the branch currents, which, as we have seen, move in undulations not only directly between the electrodes, but at a considerable distance on either side of the median line between them, will be likely, in nearly all forms of application, to touch healthy parts that do not stand in especial need of treatment. The most complete form of localized electrization is electrolysis when the needles are placed close together, but even here the reflex effect is most powerful, and operates with a mild as well as with a strong current.

But fortunately it is never necessary to localize electricity, in the strict sense of the term. It is sometimes necessary, however, to avoid producing too strong reflex effects, and in applications near sensitive parts the possibility that the branch currents, if powerful currents are used, may over-irritate, should ever be borne in mind. Experiment and experience show that healthy animals and men can be electrized with benefit all over the body, or in any part of it. In applying electricity to any part of the body we improve the nutrition of that part ; in applying electricity to the whole body we improve the nutrition of the whole body, or, at least, of those parts which are directly or indirectly influenced by the current. Faradization of a healthy muscle makes it grow faster than it would grow without faradization ; in other words, it produces the same effect that it would if the muscle were paralyzed. When a part is in a pathological condition—when, for example, a muscle is atrophied—any improvement in nutrition under electrization is more quickly observed, and is probably more rapid and important than when the same muscle is treated in a physiological condition ; but the improvement of the healthy muscle is none the less real, though it may be relatively less important than in the diseased muscle.

The tonic effects of general faradization and of central galvanization, and, indeed, of many forms of localized electrization are due to the direct or indirect action of the current, on parts which are more or less healthy, or which, to say the least, are not in any recognizable patho

logical state. The objection sometimes brought against these methods that they do thus affect healthy parts, simply attempts to prove too much. The same argument would banish all, or nearly all our stimulants, tonics, and sedatives from our *materia medica*, and practically discourage all attempts to relieve or cure chronic diseases of the nervous system.

*Dose of Electricity.*—Nearly all our medicines are prescribed by an average standard dose. This average standard is derived from experiment and experience, and, with the majority of drugs, is a safe guide in administration, although every judicious and thoughtful physician studies each case by itself, and varies the dose according to the apparent indications.

In the case of electricity, when medically employed, the dose cannot, in the present state of science, for obvious physical reasons, be arbitrarily or mathematically stated.

The dose of an application of electricity consists of these factors :—

1. The strength of the current, or the quantity of electricity that flows in a given time.
2. The length of the application.

Both of these factors are so modified in various ways that they cannot attain anything like mathematical precision. The strength of the current, or the quantity of electricity that flows through the circuit, as we are taught by Ohm's law, is the electro-motive force divided by the resistance. We have previously shown (in *Electro-Physics*, chapter vii.) that both of these factors are susceptible of almost infinite variations, some of which are and others of which are not understood.

In the time of the application there is less vagueness, but even in this factor the precision is more apparent than real ; for the effect of electricity depends so much on the manner in which application is made, whether with interruptions or without interruptions, whether with large or small electrodes, etc. The method of the application, whether local or general, and if local, to what part, and how directed, also modifies seriously the determination of the dose from the length of the application. Ten minutes of general faradization or central galvanization will have a much more powerful general effect than ten or even twenty minutes of local electrization. Five minutes of galvanization of the brain will accomplish more good or evil than fifteen minutes' faradization of the uterus, or of any one of the extremities.

The time may yet come, in the advance of science, when electrical measurement will attain such a degree of precision that we shall be able

to prescribe so many *farads* of electricity, as we now prescribe so many grains of quinine, or so many drops of laudanum ; but the day when such exactness shall be possible in applications to the human body is probably not very near. Our present method of measuring the galvanic current by the number of degrees of deflection of the needle of a galvanometer is very unsatisfactory, for the twofold reason that the deflection beyond a certain angle does not accurately represent the relative strength of the current, and especially because when applied to the body a different and varying resistance is encountered, which at once destroys the value of the comparison. Electro-therapeutists have sometimes stated the amount of the deflection which the current caused before being applied ; but all such statements are of little or no value, and particularly when we do not know the construction of the particular galvanometer which they employ. A further difficulty in measuring electricity by the galvanometer, is that the strength of the current in most of the batteries in common use declines during the applications, so that a current which is powerful at first may in the course of ten or fifteen minutes be only medium.

The graduated scale on some of our faradic machines, and which indicates the number of inches that the rod or helix or tube is moved, is also a practically useless guide, except as far as it may be resorted to to encourage and amuse silly and weak-minded patients. In any faradic machine the strength of the current in the cell, and consequently the strength of the induced current in the coil, varies from day to day, and varies during the application ; and the amount that passes through the patient is dependent on the size of the electrodes, and the amount of moisture in them, and their relative position.

In default therefore of any trustworthy means of prescribing electricity by farads, or other definite measures, we are compelled in practice to depend on these two indications :

1. *The sensations of the patient.*

Very fortunately the sensation of the patient during the application indicates with considerable correctness whether the current is of the proper strength. *The rule is that where strong currents are borne without discomfort strong currents are beneficial ; where only mild currents are borne only mild currents are indicated.* The difference in the natural sensitiveness of patients to electricity is very great. This difference is further modified by disease. In anæsthesia local and general, in sclerosis of the nerve centres, and certain local affections, very powerful currents cause but little pain. On the other hand in hyperæsthesia, in hysteria and allied affections as a rule, and in acute and subacute

local inflammations, only mild currents can be borne. To disregard the feelings of the patient and make the applications exceedingly painful will tend to produce the evil rather than the good effects of electricity. To give only mild applications when painful ones could be well borne is to rob the patient of a part of the benefit to which he is entitled.

To the rule that the sensations of the patient are the guide in electrical applications there are some exceptions, just as there are some exceptions to the rule that the appetite is the guide in the quantity of food that we eat. It is partly to guard against these exceptions, and to keep on the safe side, that the first few applications on a new patient whom we have not before treated by electricity, should be mild and short.

Not only do different individuals vary in their sensitiveness to electricity, but different parts of the surface of the body in the same individual also vary, as we have seen through a considerable range; and in the cavities of the body and on the mucous surface the range of variation in sensitiveness is yet greater. The mucous membrane of the mouth, tongue, urethra, is very sensitive, and this sensitiveness should be respected by the electro-therapeutist.

There are some quite rare cases of hysteria where the great sensitiveness of the patient may be disregarded, or chloroform or ether may be administered. The sensitiveness of the patient is a guide only or mainly in regard to the *strength* of the current. In regard to the length of the application we must be guided by—

2. *The immediate, secondary, and remote effects.*—This second guide serves to correct the mistakes of the first. A meal that disagrees with us may show its ill effects in a few minutes or hours, or the following day. Similarly we should study the effects of electrical applications. So far as any one or all of the good effects described in this chapter follow an application, so far we may judge that the application has done good; so far as any or all of the evil effects described in this chapter follow an application, we may judge that it has done evil. The evil and the good effects may sometimes be associated. To rightly interpret these effects, and to distinguish between those that are produced by the applications and those that are produced by moral, hygienic or medical causes is one of the severest tests of medical skill. There is less liability to deception in studying the immediate effects, since there is less chance for other forces to complicate the results. After a few hours, the complications of diet, exercise, weather, medicine and so forth begin to appear, and obscure the effects of the

electricity. The secondary and remote effects can therefore only be ascertained by repeated observations. A single application gives us little opportunity to answer the question whether electricity is really the remedy that the case requires.

One caution must not be forgotten: the immediate and secondary effects *may be evil* while the *remote effects may be good*.

A long walk that much fatigues us is often beneficial, though the benefit does not appear for several days. Those who take travelling vacations to recruit exhausted energies, frequently feel worse while they are travelling, but are stronger on their return and for months following. The fatigue and soreness and stiffness that sometimes follow skating and gymnastics, and other exercises, do not always indicate that benefit has not been derived. The next day the appetite and spirits may be better, sounder sleep may follow; the evil and the good effects contend for the mastery, and the good effects triumph.

*The best results of Electrical Treatment usually obtained with Mild Currents.*—For the average constitution, and with the exceptions that come from certain idiosyncrasies and certain diseases, such as anæsthesia, the best results of electrical treatment are obtained by *mild* currents.

The temptation to disregard this rule and use painful currents is, even for the experienced electro-therapeutist, very great, and sometimes irresistible. The dogma, "no smart no cure," which has wrought so much misery in the world, still lingers, even among the intelligent.

The descendants and near relatives of the man who growled at his dentist for extracting his tooth without pain or bluster, because he had been accustomed to being hauled all around the room during that operation, are yet very numerous. Even in cultivated circles there can be found those who have no faith in medicine unless it is bitter, and no respect for the doctor unless he half kills them. Then again some patients make a virtue of bearing pain, and will pretend that they do not feel the current when they know they are suffering all the horrors of the damned. Moreover, mercenary patients wish to get their money's worth, and if they pay so many dollars for an application, they want so many dollars' worth of agony. For all these reasons combined, we are, in spite of our experience and caution, continually making the blunder that we here warn against. Over the doors of the electro-therapeutist, and in full view of the operating chair, we would inscribe this motto, "Better give much too little than a little too much."

*The use of Salt on the Electrode.*—A very good device to prevent using too strong currents, particularly the *galvanic* current, is to saturate the

sponges or cloths of the electrode with plenty of salt water. Salt water is a good conductor, much better than simple water, and will cause the patient to sensitively feel a current, of which, if the salt water were not used, he would not be conscious.

With the same strength of current, a sponge or cloth electrode saturated with salt is more painful than a similar electrode not so saturated. The current when conducted though salt seems to pass in points from the electrode to the body just as when conducted through metal or the metallic brush. In a word, an electrode saturated with salt not only conducts a greater quantity of electricity, in accordance with Ohm's law, but conducts it more painfully than an electrode saturated with ordinary water.

*Care in the Details of the Applications.*—There is as much difference between a skilful and an awkward application of electricity as there is between a skilful and an awkward operation in surgery. By those who desire to become experts in applying electricity, the following points should be considered :

1. To avoid suddenly interrupting the currents in cases where interruptions are not required, and especially in applications on or near the head. In the treatment of paralysis of motion and of sensation, interruptions are required, but in the treatment of the brain, spinal cord, and sympathetic, and in very many peripheral applications *stable* currents only are required. In all such cases the current should be closed gradually and delicately, if possible by means of a rheostat of some kind, or by increasing or diminishing the pressure on the sponge of the electrode. Interruptions made in the metallic part of the current are always more sudden and violent than those made in the electrodes, for the physical reason that the connection of the current is more sharp and abrupt.

Delicate patients should be treated with delicacy. Those who are sensitive and apprehensive should never be annoyed by sudden breaks in the current, except in those forms of disease where sudden breaks are required.

In presenting this caution we do not intend to endorse the notion that serious pathological lesions are caused by interrupting the current, even on or near the brain. There is little or no evidence besides the case of Duchenne, that any serious injury to the retina, or to the auditory nerve, or to any part of the brain, or sympathetic, or spinal cord, has been produced by faradization or galvanization with the strength of current ordinarily employed in electro-medical applications. The dizziness, the sour taste in the mouth, the flashes of light before the eyes,

the shock or agitation produced by the sudden interruption of the galvanic current, are annoying, and to the delicate patient unaccustomed to them, sometimes alarming, but with the batteries in ordinary use, and with the strength of current that is, or ought to be employed through the head and neck, they are rarely if ever dangerous: they are temporary effects that soon pass away, and are forgotten. But they are to be avoided in cases where they are not required, for the three-fold reason that they do no positive good, that they may interfere with the success of the treatment, and that they alarm or annoy the patient. We are to avoid worrying our patients in this way, for the same reason that we are to avoid treading on their corns, because it is disagreeable and discourteous.

2. To avoid making the applications unnecessarily painful through carelessness in the management of the electrodes. By the use of fine and soft sponge—the best that can be found in the shops—the smarting and stinging pain of the applications can be much diminished. Aside from the fact that, with some exceptions, less satisfactory results follow painful than pleasant currents, the feeling of pain should, so far as possible, be avoided. There are, as we have said, a certain number of patients who carry into medicine the same views that once dominated in religion, and who desire to suffer, and have very little respect for any treatment that does not cause more or less agony. Such patients will sometimes find, after one or two severe and painful applications, that they are injured more than benefited, and will submit to the advice of the physician and take the treatment that is best for them.

3. To avoid surprising and startling the patient by allowing the wires, or the metallic portions of the electrodes, to touch any part of his exposed body. If the connecting wires slip out of their connections with the electrodes they are liable to fall on the exposed skin and give a painful shock. If the edge of the electrode not covered with sponge or cloth touches the skin, it will give the patient sudden pain, and annoy both him and the operator. Connecting wires that are not protected by rubber are liable to lose their silk or cotton coverings in places, which when they touch the skin cause pain.

4. To be always and every moment sure that the current is running. The batteries should be tested before the application, either by the galvanometer or through the hand or person of the operator, that he may be sure that it is in order, that the connections are properly made, and that the electrodes are sufficiently wet to conduct the current. When mild currents are used, salt may be added to the solution in which the electrode is dipped, so that a slight stinging sensation

beneath the electrode, may keep the patient assured that the current is passing.

*Disrobing of the Patient.*—The great majority of electrical applications require, on the part of the patient, more or less loosening or removal of the dress. Not only is this necessary in general faradization and central galvanization, but in very many local applications to the spine, abdomen, and upper and lower limbs,—excepting merely the face, head and hands. To know how to direct the patients to arrange their clothing so as to give the operator sufficient and easy access to the person, is a part of the art of practical electro-therapeutists, and it is an art not to be despised. Male patients have less trouble in this regard than female patients, since their garments are fewer and simpler, but they are more annoyed by the little they have to do than women are by their vast paraphernalia. The art consists in *loosening and pulling up without entirely removing the under-clothing, thus avoiding trouble, exposure and waste of time.*

*Temperature of the Electrodes and of the Operating Room.*—The question is often raised by patients whether there is any danger of taking cold after an application of electricity. The answer is clearly in the negative. The electricity, as such, so far as it goes, fortifies the system against cold; but, by careless exposure while undressed in a cold room, it is possible to take cold, just as by similar exposure when electricity is not used. It is also possible to make the application quite uncomfortable by using sponges moistened with cold instead of tepid water. Our aim should be to have the temperature of the operating and dressing-room a little higher than is necessary for a person fully dressed; to moisten the sponges or electrode covers in tepid or—in very cold weather—in hot water; and when the feet are placed on a foot-plate of tin or copper, to have a warm soapstone beneath the foot-plate to keep it always comfortable.

*Time of day for the Application.*—Applications of electricity may be given with advantage at all hours of the day and night. In our experience, and probably in the experience of all electro-therapeutists, the majority of the applications are given in ordinary business hours, in the forenoon and afternoon. We have never been able to see that anything was gained by giving any particular heed to the hours of eating; just before meals, and just after them, ordinary electrical treatment may be given with apparently as much benefit as two or three hours from a meal. In some impressible temperaments, central galvanization and general faradization temporarily increase appetite, and for such persons an application might very properly be given a little before meals. For



those who suffer from dyspepsia, a seance pretty soon after dinner might be of service in aiding digestion, but we cannot say that we have seen any such results.

For all delicate, hysterical, sleepless patients, the evening is an excellent time to receive electricity. The powerful sedative effects of central and general electrization are in this class of patients most gratefully realized a little before going to bed, or after they have already retired. For these reasons we have, for years, been accustomed to treat some of our patients in the evening, before or shortly after retiring, and, were it not for the inconvenience, we should do it more frequently.

*Time of Applications.*—The time of an application is an element of the dose of electricity that has not been sufficiently studied. Electro-therapeutists have fallen into the conventional and routine habit of using the current all the way from five to ten or fifteen minutes or so, at a sitting, without sufficiently investigating the question whether the length of the application ought not to be varied with studious care, in each case, and varied during the course of treatment.

For irritable, sensitive and impressible patients this law certainly holds; *that long applications with mild currents are better than short applications with strong currents.* This law, which is the outcome of all our observations in the department of electro-therapeutics, applies to all modes of using electricity.

A sudden shock, or a series of shocks with a powerful current, may injure, where a prolonged application with a gentle current may work no harm and much good. That this element of time becomes a practical difficulty in the use of electricity by overworked general practitioners, must be admitted: but if it be a scientific fact—as it surely is—that time is required to gain the choicest and best effects of electrical treatment, then we must recognize and accept the fact, and treat our patients accordingly, and expect them to reward us for our labors more liberally than for a mere prescription or suggestion.

We insist on this point, because we feel that through neglecting it many mistakes have been made, and through a disposition to neglect it there is danger that in some minds electro-therapeutics itself may fall into disrepute. While many patients and many cases do well under five or ten minutes of electrization, very many others, especially after they have become accustomed to it, require at least double that time.

With all our might, we should avoid the error of supposing that the best effects of electrical treatment will succeed by short applications with strong currents. In this way we may both save time and lose our patients.

Economy of this sort may prove to be the worst of extravagance.

*Frequency of the Applications.*—Ordinary stimulating and tonic medicines are given one, two, and usually three times a day. The dose of electricity cannot usually be administered so frequently without doing more evil than good. It seems essential to the electro-therapeutical treatment, whatever the mode employed,—general and local faradization, central and local galvanization, and even electric baths and the use of the body batteries,—that there should be *a considerable period of rest between the applications.*

Electrization sets in motion forces that slowly act and react hours and days after the electrization has ceased. The time required for these forces to operate to the best advantage varies with individuals, but in all cases a certain period of rest is required, and if the application be repeated before this period or some portion of it has elapsed, the benefits of the previous application are more or less neutralized, and the patient may be weakened more than strengthened. This at least appears to be the conclusion that long experience forces upon us. All the way between every day or once a week the applications can be given with benefit. Three or four times a week is about as often as the average patient cares to make his visits, and it is safer to begin treatment with at least an interval of a day or two between sittings. Some patients require at the outset of a course of treatment, intervals of three or four days. If by accident or intention, strong and long applications are made, unpleasant reactive effects may follow that at once suggest the necessity of waiting for a day or two. Many a time does it happen to us to visit a patient, and, on learning the history of the symptoms, to put off the application twenty-four or forty-eight hours.

On the other hand, there are those who can take full applications every day for a month in succession, and in some cases, as it appears to us, with greater benefit than would be derived from applications given every other day. At the founding of the Electro-Therapeutical Department of Demilt Dispensary, we received patients only twice a week, and good results were obtained under that system, but we afterwards found it desirable to add another day. In private practice we make the applications more frequently than at first, and find an advantage in so doing, for the reason, mainly, that we use milder currents than formerly, and our patients can bear and be profited by more frequent sittings.

General and central applications require longer intervals than local and peripheral applications, for the patent reason that they more powerfully affect the whole system, and are more frequently followed by reactive effects.

In rare cases,—when the patient has but a short time to remain in town, or when an intolerable pain is to be relieved,—we have given applications twice a day, but have not usually obtained any advantage thereby. Chronic nervous diseases cannot be cured in a day; time is as necessary as the electricity. Long standing pathological lesions are not to be carried by assault, however bravely conducted; they yield only to a protracted siege.

*Regularity of the Applications.*—It is the custom with some electrotherapeutists to insist on regularity in the days and hours of the applications, and there are those who believe that the best effects follow regular and methodical treatment. On this point we are in some doubt. Patients who are methodical in their habits, and who are regular in their visits, will be less likely to omit visits, and will be more likely to persevere, and consequently will be more profited than those who omit half of their visits and abandon treatment before it is fully tried. There is no evidence that regularity, as such, is any advantage; although there is strong probability that for some constitutions, and, perhaps, for diseases with periodic symptoms, it might be an advantage to give the applications at the same hour daily, or every other day, as the case may be. Our own custom in this regard varies. Practically we find it impossible to treat all patients with absolute regularity, and in those cases where we are able to do so we have not, thus far, been able to see any special therapeutic advantage.

*Prolonged Applications.*—A method of using electricity that has been too little studied by the profession is that of *prolonged applications* with mild currents.

In certain *diseases*, both medical and surgical, it is of advantage to allow the current—galvanic or faradic—to run for several hours—all day or all night—as may be convenient.

We have become so accustomed to the use of short, or comparatively short applications, that we forget that the current if sufficiently gentle may be passed through the body, or part of the body for hours, if not days consecutively, without injury, and with great benefit, provided certain cautions are observed.

When the galvanic current is thus used, care must be taken not to allow the sponges, or metals, or cloths, to remain too long in one spot, since they will cause a disagreeable though not serious ulceration of the skin, that may be some time in healing. In order to avoid this ulceration, it is well to use sponges instead of metals, and to change from time to time the position of the electrodes, so that they may not act too long on one spot.

The details of this method of using electricity must be varied with each case and the circumstances of the patient.

*Intervals between the Courses of Treatment.*—It is sometimes of service to suspend a course of treatment after it has been going on a number of weeks, and to allow an interval of one or more weeks, according to circumstances. It is sometimes observed that patients improve as much during the interval as during the treatment, and when the applications are renewed, they have greater force than at the close of the course of treatment. It is true of electricity, as of almost every other stimulant, tonic, sedative remedy, that after receiving it a certain time the system becomes so accustomed to it as to tolerate it, and then its full force is not appreciated. In cases where this toleration of electricity is observed, when the improvement halts, so to speak, a brief suspension of treatment may be indicated, and on renewing it, all the benefit at first realized may be repeated.

On the other hand, there are patients who seem to prosper best under steady, uninterrupted treatment.

*Combination of Methods of Application.*—Comparatively few diseases are to be treated solely by any one method of application; many of the purely local affections ever yield better to electrical procedure, when the applications are varied, than when one mode only is persistently used. Both currents, galvanic and faradic, may be tried in alternation or succession, and both the direct and indirect methods may be employed at the same sitting or at different sittings. In all diseases where the whole system is involved, the method of application may be yet more varied. General faradization and central galvanization may be used alternately, and the alternation may be by the day or week. These methods may be varied with galvanization of the brain in all directions, galvanization of the pneumogastric and sympathetic and of the spine. In some diseases, as notably in those where central lesions are accompanied by peripheral injury and general exhaustion, as hemiplegia, ataxia, and so forth, all the methods of application may be used, including faradization with the wire brush. We observe not unfrequently that after one method of electrization has done all that it is capable of doing, after it seems to have lost its power, another method of electrization, or a mere modification of a method, may push the improvement yet further, until it in time loses its force and the fresh stimulus of another method is required.

In this respect the behavior of electricity is in no way peculiar; to all powerful remedies the system in time becomes so accustomed, as to tolerate them without appreciating their remedial influence. In the

administration of tonics in cases of debility, and of astringents in cases of chronic diarrhœa, a necessity for frequent change of remedy is generally recognized.

*How to judge of the Effects of Electrical Treatment.*—It is of the first importance for the electro-therapeutist to have a clear, just and systematic method of determining the effects of electricity, both good and evil. Much of the difference of opinion that prevails among those who use electricity, as to its general and special value, and much of the prejudice that exists against electro-therapeutics is the result of a want of a knowledge of the tests by which the action of electricity on patients is to be determined.

When we give opium, we know very soon whether it relieves pain and produces sleep, or, as not unfrequently happens, has effects precisely opposite. We learn to judge without great difficulty whether the chloral and quinine are doing the work that we desire. With stimulants and tonics, as used in the chronic affections, greater difficulty is experienced, but there are certain tests which we study and look for and by which we are guided. The effects of electricity should be similarly studied.

The good effects of electrization are in general as follows :

1. *Relief of Pain and Disagreeable Sensations local and general.*—This relief may appear shortly after the application is commenced, after it has been continued for some minutes, or at its close. In some cases there is no relief during or immediately after the sitting, but several hours subsequently. We include painful sensations of every kind—the vague wandering pains of neurasthenia and hysteria, the burning of inflammation as well as real neuralgia.

2. *Improvement in the Pulse.*—Where the pulse is abnormally slow it may be quickened both during and for some time after the sitting. Where it is abnormally rapid it may be lowered. The pulse, therefore, may be a guide in the administration of electricity, as it is a guide in the administration of alcohol and various other forms of stimulants and tonics. If the quiet pulse is made much quicker and so remains for some time, we may suspect that the application has been too strong or too long.

3. *Improvement in the Temperature of the Body, or of the part which is treated.*—Parts that are abnormally warm are cooled, or as is more frequently the case, parts that are abnormally cold are warmed, during and subsequent to the operation. The temperature may be tested by the sensations of the patient, by the touch of the operator, or by the thermometer.

4. *General calming Influence and Disposition to Sleep.*—Nervousness is allayed, just after taking wine, or food, or a bath, or a drive by the sea. The disposition to sleep comes on usually after the application, in rare cases during the sitting, especially when the head or neck is galvanized.

5. *Mental Exhilaration.*—The effect of sea-bathing, or the inhalation of oxygen, is to exhilarate in a way that defies minute analysis. The effect of electrization is similar. This effect is seen more strikingly in hysteria and hypochondriasis.

6. *Increase of Appetite and Improvement in Digestion.*—In some instances the appetite is sharpened by a single sitting; the permanent improvement is, of course, a slower effect, and is only observed after a number of applications.

7. *Improvement in Local and General Nutrition.*—To accomplish improvement in nutrition is the great object of electrical treatment. The relief of pain and of other special symptoms, during a sitting, may justly be regarded as results and accompaniments of improvement in nutrition. At a later stage of a course of treatment, the improvement in nutrition may be seen and studied by the senses. Improvement in local nutrition is produced by local electrization, improvement in general nutrition is produced by general or central electrization. Peripheral local electrization, may, however, reflexly produce improvement in general nutrition, particularly when prominent organs, as the uterus, the stomach, and liver, are treated.

The evil effects of electrization, by the occurrence of which we may suspect that the applications are too strong or too long, or improperly given, or that wrong methods are used, or that the temperament and disease of the patient contra-indicate electricity, are, in general, as follows:

1. *Headache and Backache.*—Sudden shocks, or interruptions of the current, may cause momentary headache that passes away as quickly as it came. When the headache persists for a considerable time, one may know that there has been somewhere a mistake in the application. Backache follows as a rule only general or central treatment.

2. *Irritability and Insomnia.*—Patients may feel nervous, irritable, and indefinitely disagreeable after an application, and the sleep the following night may be less sound and more disturbed by dreams than usual. These are evil effects, and are to be guarded against.

3. *General Malaise.*—This symptom, which is the reverse of the exhilaration spoken of among the good effects, appears not unfrequently after an over-dose, especially of general faradization. It sometimes,

though less frequently, follows central galvanization, and there is no form of local electrization, central or peripheral, that may not in some temperaments and conditions give rise to it.

4. *Excitation or Pain, or Increase of Pain already existing.*—Neuralgia is sometimes increased on the application of the current, and particularly when the currents are strong and interruptions are made. A harsh and rough faradic current, even when mild, may aggravate pain. Sometimes there is no effect during or immediately following the seance; but in the course of a few hours, the pain is excited or aggravated.

Similarly the pains that accompany malignant tumors may be excited when electricity is applied during an interval, or they may be increased if treated during the paroxysm.

5. *Over-Excited Pulse.*—The pulse may indicate whether the application has done good or harm, with some considerable certainty, provided the operator is sufficiently familiar with the normal pulse of the patient. This familiarity can only come from previous acquaintance. A stranger, seeing a patient for the first time, and treating him by electricity, is quite likely to be deceived. The pulse may be over-excited by the mere coming in of a new physician, or by the thought or dread of electricity. Thus the value of the pulse as a means of determining the degree of the ill effects of an application is much diminished. As a test of the good effects of electricity, it is much more worthy of trust.

6. *Chilliness and other Nervous Sensations.*—An application which has been made injudiciously may be followed almost immediately by a feeling of chilliness, as though the patient had taken cold. There may be also a stiffness of the neck, and pain on turning the back, as though the patient were rheumatic, and heat and burning in the spine, and crawling, creeping, pricking, stinging, sensations in the face, down the back, and on the limbs and other parts of the body.

These sensations are not due to a cold, as is sometimes supposed,—for, except through gross carelessness, patients do not take cold during an application of electricity,—but they are merely nervous sensations, of an hysterical character, precisely like the symptoms described under hysteria and allied affections, and are due to over-irritation of the spinal cord, and perhaps also of the sympathetic. They more frequently follow faradization than galvanization, especially when a hard, rough, unpleasant current is used. They appear only in the exhausted and neurasthenic, and most frequently in women.

7. *A feeling of Soreness, Stiffness, and a dull Aching.*—These sensations are closely allied to those described in the preceding paragraph :—

they are the result of over irritation of the nerve-centre ; the soreness that is felt in the muscles after severe faradization is somewhat like that which is experienced after violent exercise in the gymnasium, on skates or on horseback.

The dull, aching pain through the whole body is like the sensation that is experienced after taking cold. It is a purely nervous sensation and is caused by over-irritation of the spinal cord. One patient whom we treated for an exhausted and irritable condition of the cord, resulting from cerebro-spinal fever, persisted that every application caused him to "take cold."

8. *Profuse Perspiration.*—Gentle perspiration is one of the good effects of electrization ; it is observed both after general and local treatment. But profuse perspiration of any part, as the head, or one of the limbs, or of one side of the body, or of the whole body, occurring during a séance, or directly following it, is a bad symptom, and indicates over-irritation. In some hyper-sensitive conditions profuse perspiration may appear under a very mild current, and at the outset of the application. We have known a paralyzed arm in hemiplegia break out with abundant perspiration. In cases of cerebral and spinal irritation we have known the forehead and the hands to perspire freely during the application. Some constitutions are specially impressible in this regard. We once treated a case of paralysis of the bladder by external galvanization ; the patient was of the average strength and health, but in less than five minutes his whole body was as freely perspiring as in the hottest summer day. Nausea and faintness also came on and stopped the application.

9. *Prolonged Reaction of the Nerves of Special Sense.*—In the section devoted to Electro-Physiology, we have seen that the nerves of special sense, the auditory, the olfactory, the ophthalmic and the gustatory nerves, all have their special and peculiar reactions to electricity. These reactions are normal and physiological, but in degree and variety they are greatly influenced by temperament. These reactions are, on the part of the auditory nerve, hissing, rushing, boiling, seething sounds ; on the part of the ophthalmic nerve and retina, flashes of light ; on the part of the olfactory nerve, under a powerful and painful current, peculiar phosphoric or ozonic odor ; on the part of the gustatory nerve, an acid or coppery taste. For the great majority of temperaments in health or disease, these reactions disappear with the cessation of the application ; but where there is special susceptibility to the electricity, or when very severe or prolonged applications have been made, some of these reactions may continue for hours or days. Thus we have known patients to



complain of the peculiar taste in the mouth two or three days after an application. The buzzing in the ears also does not always stop when the current is opened, prolonged flashes before the eyes are sometimes noticed, though but rarely. Prolonged reaction of the olfactory nerve we have never observed.

We call these prolonged reactions evil effects, because they appear in very susceptible patients, or after careless procedures, and are usually accompanied by other effects that are unmistakably evil.

*Disturbances of the Nerves of Motion and Common Sensation.*—Under this head we include hyperæsthesia, general or local, that an overdose of electrization sometimes produces in nervous and hysterical patients, or the opposite condition of anæsthesia and muscular spasms, contractions and rigidity. These phenomena are not frequent, but in rare instances they have been observed; muscular spasm, where it already exists, may be aggravated temporarily by electricity.

*Hygiene of Patients after the Applications.*—Patients who are strong, and are treated for purely local troubles, may be entirely indifferent in regard to their behavior after electrical applications; they may exercise brain or muscle, or remain idle, as may be convenient, and the improvement under the treatment will go on just the same. But delicate patients who are treated for grave conditions of debility, and especially females, do better to avoid exertion after an application: better for them to sit awhile, or rest on a lounge, and if they are treated in bed to remain there; and this, we believe, is another advantage in treating such cases just after retiring.

If any fancy they take cold as a result of an application, it is a pure fancy, or it is the nervous chill that sometimes follows over-electrization, or it is the result of exposure in a cold room while undressing.

*Cumulative action of Electricity.*—It sometimes happens in the treatment of a painful and tender nerve, that a sudden shock is felt, after the electrodes have been a long time in position, even when the current is very mild and is scarcely felt on the surface.

A medical friend, who by our suggestion treated a case of ulcer of the stomach by the galvanic current, informed us that a very mild current from a few zinc carbon cells, which gave no burning sensation on the surface whatever, would, after the electrodes had been kept in position a few minutes, one on the epigastric, and the other on the back, cause all of a sudden and without any warning a painful shock, as though a strong current had been suddenly interrupted in the metallic part of the circuit. This phenomenon occurred so often that he abandoned the treatment.

We have occasionally made the same observation on other parts of the body. Thus, in a case of sciatica that we were treating by the galvanic current—one pole on the course of the nerve below the trochanter, and the other on the back—only a very slight sensation was felt for two or three minutes, when all at once the patient gave a jump as though shocked by a powerful current. A number of times during the seance the experiment was repeated. Every pains was taken to avoid error by assuring ourselves that the current was actually running all the time, and that there was no actual interruption.

This cumulative action, if we may call it such—would seem to be somewhat analogous to the cumulative action of strychnine and some other remedies. The rationale of it is in the present state of our knowledge hard to determine. It may be that as the skin becomes more and more moistened, its conductivity so increases that a portion of the nerve is traversed by the current which at first was not touched, and that this physical explanation is sufficient. It may be that the nerve, already in an irritable condition, may have its irritability so greatly increased, that it develops it suddenly under continued though mild stimulation. We have, as yet, no evidence that such shocks are specially harmful, although they are unpleasant and startling. They can be avoided as a rule by shifting the electrodes every moment, so as to avoid a long irritation of any one spot.

*Increased Toleration of Electricity.*—The system can become habituated to electricity just as it becomes habituated to alcohol, or opium, or any other potent remedy. After a long course of treatment, extending over several months, nearly all patients bear very much longer and stronger applications than at first. This is observed in those whose sensitiveness to electricity is at first extreme. It is not therefore necessarily a discouraging fact if at the outset of a course of treatment very gentle currents and very short sittings are required.

*The Temperament, as well as the Disease, to be considered in using Electricity.*—There are individuals whom electricity always injures, the only difference in the effect on them between a mild and a severe application being, that the former injures less than the latter. There are patients upon whom all electro-therapeutical skill and experience are wasted; their temperaments are not *en rapport* with electricity.

It matters not what may be the special disease or symptoms of disease from which they suffer—paralysis, or neuralgia, or neurasthenia, or hysteria, or affections of special organs—the immediate and the permanent effects of galvanization or faradization, general or localized,

are evil and only evil. We have not arrived at this opinion by theorizing ; we have been driven to it by the accumulating and irresistible logic of facts. The first query that arises, in the mind of the electro-therapeutist, when a case under his care responds badly, is, "Am I rightly using this remedy ; am I making the application too long or too severe, or by improper methods? Would a change of current be desirable?" But after we have tried all electrical applications ; after we have gone from galvanism to faradism, from general to localized electrization, from long and severe to short and gentle treatments ; after we have rung the changes on all these, and yet persistently aggravate rather than mollify the disease, and instead of strength and relief, produce weakness and distress, and instead of calmness cause irritation,— then we have only to make as graceful a retreat as possible, and put that patient down as a case that was not born to be treated by electricity. We have no explanation to offer of the phenomenon ; and the popular belief or supposition, that the excess or deficiency of animal electricity has something to do with these matters, is as undemonstrable as it is plausible ; he who should attempt to prove or disprove it would find he had undertaken anything but an easy task. It would seem to come in the list of those strange but familiar likes and dislikes in regard to certain articles of food or drink, or of certain sights or odors. We know of no physiognomical or rather external appearances by which to determine whether a patient does or does not belong to the unfortunate few who can have no lot or share in electro-therapeutics. The strongest equally with the weakest, the plethoric and the enervated, are found among these Gentiles of science.

The reverse proposition, that there are certain constitutions for which, by whatever form of chronic disease they may be afflicted, electricity is always indicated, is equally true. There are patients who find in electrical treatment almost a specific. Whether they suffer from dyspepsia or neurasthenia, from hysteria or diseases of special organs, rheumatism or neuralgia, electrization always relieves them up to a certain point, at least, if it does not positively cure. *The broad fact to be understood is, that it is not so much the disease or the symptoms, as the temperament that indicates or contraindicates electrization.*

While some chronic diseases are more amenable to electricity than others, among all patients there are individuals to whom it is a matter of indifference what special affection they may suffer from ; so long as improvement in local and general nutrition is indicated, they will be benefited by electrical treatment.

To all this it should be added that some persons are *indifferent to*

electricity—they can bear almost any strength of either current very frequently and for long applications, without experiencing any effect either good or evil. Electricity may be poured over them in limitless measures; they may be saturated with it, and they may come out from the applications not a whit better or worse. Patients who are quite delicate and sensitive exhibit this supreme and provoking indifference to electricity. We are inclined to believe also that patients vary in *their susceptibility to electricity at different times of life*. Susceptibility to stimulants and narcotics oftentimes undergoes strange modifications during the lifetime of an individual. Those who at one time cannot drink coffee, sometimes find that a few years so modify the temperament that they can drink it with absolute freedom, and *vice versa*. Similarly, also, alcoholic liquors act in a most capricious way, sometimes benefiting, at other times injuring even when nearly all the other conditions except age are the same. Idiosyncrasies in regard to certain articles of food are by no means constant through life—they may change either way, and that too in the course of a few years; they may be modified by febrile or other diseases that revolutionize the system, or by residence in various climates, or by mere lapse of years. Analogy would lead us to suppose that susceptibility to electricity might also be thus modified, and our observations seem to convince us that such is the case.

We are further inclined to believe that susceptibility to electricity, favorable and unfavorable, like all other constitutional tendencies, is subject to the laws of hereditary descent, and runs in families. We have treated by electricity three members of the family of a physician, who are afflicted with quite diverse maladies, but all of whom not only improved under the treatment, but can be electrized with great freedom by either current; and yet none of them are strong, and two of them are delicate.

On the other hand, we have treated families where several of the members are so susceptible to the electric current that the application must be made with great care lest unpleasant results occur. We are fully convinced also that the proportion of those who do *not* bear electricity well is larger among the higher than among the lower classes; in hospital and dispensary practice, the number of patients who exhibit excessive susceptibility to the electric treatment is quite limited, whereas in private practice, among the intellectual classes, one out of five or ten, take the cases as they run, must be treated with very considerable caution, lest disagreeable symptoms arise.

*Relation of Electro-susceptivity to Prognosis.*—Between electro-suscep-

tivity and prognosis there would appear to be no constant relation. One patient may be extremely susceptible to electricity, and another capable of bearing it in large doses, and both shall be benefited. If there be any law in the matter it is this, that those who occupy the medium ground, who are neither specially sensitive nor the reverse—offer the best prognosis under electrical treatment. It is equally sure, however, that those who are exceedingly sensitive may become so tolerant of the remedy as to derive great benefit from it. For this reason we should not be discouraged, even by extreme electro-sensibility or electro-susceptibility in our patients.

The most provoking class are those who cannot be influenced in any way by electricity, but who can even from the very first receive it in enormous doses without showing or feeling any good or evil effect, and yet even such cases may by protracted treatment be benefited.

*Regard for Age.*—In the apportioning of the dose of electricity the only general rule to be considered is, that the extremes of life—the very young and the very old—demand rather more caution than those in youth and middle life. It is not however necessary to divide the doses of electricity for infants and children, as we divide the doses of ordinary medicines; children from three years down to three months and even younger may be treated by general faradization and central galvanization almost as freely as adults. On theoretical considerations, and in order to be on the safe side, we do not usually treat very young children as long, or with as strong currents as adults, nor quite so frequently, but we have not often seem any especially bad results from quite prolonged applications, provided mild currents are used. The rule is to give the average baby about half as much treatment as the average adult. Children cry when the current hurts them, and this to the merciful physician operates as a check against over-dosing them.

Very old patients—between seventy and ninety—need to be treated with reasonable, but not extreme caution. The moderately aged—between fifty and seventy—often bear electricity better than those in the more active period—between twenty and fifty.

*Regard for Sex.*—As a rule females are somewhat more susceptible to electricity than males, and require to be treated with greater caution; not that there is any difference of susceptibility of the sexes, but because in civilization woman is more delicate than man, and more readily influenced for good or evil, by all remedies and systems of treatment. But although the law that woman is more impressible than man holds well on the average, yet the individual exceptions are very numerous. Some women—even those who are exquisitely delicate—can bear enor-

mous doses of electricity, while some men who are very hardy can bear none at all. The rule however, is constant enough to make it advisable always to begin the treatment of delicate females with considerable caution.

The higher susceptibility of women to electrical influence, makes them yield more rapidly than men to the treatment, when it suits the temperament and disease, and hence it is that many of the most delightful results of general faradization and central galvanization, have been obtained in neurasthenic, anemic, hysterical women.

The menstrual period in women does not contraindicate electrical treatment at all, but on considerations of delicacy the operations of general faradization and central galvanization cannot well be performed at that time. Local applications to the periphery can be made without regard to the menses.

*Regard for the Method of Application and the Skill of the Electro-therapeutist.*—It is not electricity in the abstract, but *electrization*,—that is, electricity applied to the body—that cures disease. Everything, therefore, depends on the method of application. Patients frequently say that they have “tried electricity” and it did no good. We have long since ceased to pay any heed to such statements, or to allow them to influence our prognosis, unless it is expressly stated who gave the electrical treatment, what methods were employed, and how faithfully the treatment was carried out. Some of the best successes we have are gained with patients who have “tried electricity” and found it wanting. What should we think of a patient afflicted with a broken leg who should say that he had “tried surgery,” and it had failed to set the bone? Would we not ask, “What surgeon? Was he a pretender, or a man of science? And did he have a fair chance?” It is possible, even if good treatment at the hands of good men failed some time ago, that the conditions may now be so altered that the same or different treatment will be successful.

It is not the remedy, it is the manner of using it that determines its value. There is as much difference in electro-therapeutists as there is in general surgeons, ophthalmologists, or aurists, or gynecologists, or obstetricians. In the ranks of those who use batteries are all grades of genius, and lack of genius, especially the latter. In electro-therapeutics two currents are used, and six different methods of application, and these methods are all capable of indefinite variations, dependent on the taste, skill or experience of the electro-therapeutist. When one mode of application fails, another may succeed; when one electro-therapeutist fails with any mode of application, another with the same

mode of application may succeed. And yet, patients with some obscure disease, that requires the best diagnostic as well as therapeutic skill, who have had, perhaps, half a dozen applications of the magneto-electric or rotary machines, at the hands of some stupid servant-girl, declare that they have "tried electricity." As well might a sailor whose broken bone had been badly set at sea by a comrade before the mast, declare that he had "tried surgery."

*The Differential Prognosis of Accidental and Hereditary Disease, under Electrical Treatment.*—The prognosis of any case under electrical treatment depends more on the *time* that the disease has been existing than on the nature of the disease itself. Very grave and severe symptoms of the most threatening character yield promptly, when they are *recent*, and, so to speak, *accidental*, while mild and nameless symptoms, that appear to be of the most trifling character, when long standing, and especially when they are inherited, may be exceedingly obstinate. It becomes therefore of the first importance to inquire how long the morbid symptoms, or other symptoms allied to them, have been existing in the patient, before making a prognosis. This principle applies to all diseases for which electricity is employed. It is illustrated in a most interesting manner in hysteria and allied affections. If two cases present themselves, both suffering from symptoms of hysteria and neurasthenia, but in one case the symptoms are a life-long heritage, while in the other they have arisen recently, and, so to speak, accidentally, the prognosis in the latter case is, other conditions being the same, consequently more favorable. Even if the symptoms in the recent case be of a severer type, the prognosis may be much better than in the inherited case. On this account it becomes necessary to inquire with diligence, and repeatedly, of the patients and of their friends, in order to see whether any allied symptoms have been their portion through life, and whether the special disturbances for which they require treatment are simply branches of a great tree of disease that has grown up in them from the moment of their inception.

When, for example, a patient appears with sciatica, or tic-douloureux, it is not enough to learn how long that particular symptom has distressed him in the present attack. The questions to be asked are : Has he ever at any period of his life had this or any other form of neuralgia ? Is he of the nervous diathesis ? Have his parents or any of his near relations suffered from neuralgia, or from any disease, or symptoms of disease that are allied to it ? On the answers given to these queries will depend our probable prognosis, not only as to the *rapidity* of relief under electrical treatment, but also as to its *permanency*.

Inherited diseases are inclined to relapse : the symptom may give way, apparently, before the force of treatment, but may reappear as easily as it disappeared, even while the treatment is continued.

*After-Effects of Electrical Treatment.*—It is a fact well recognized that the tonic effects of a trip to Europe, or to the mountains, or of a short vacation anywhere, or at any season, are frequently but little appreciated while the patient is travelling or recreating ; but appear days, weeks, and months subsequently. A debilitated man may receive no strength while on the ocean, or at the hotel, or farm-house in the country, may, indeed, seem to grow weaker instead of stronger, and may become disheartened thereby, but on his return to his duties, health may gradually, perhaps imperceptibly, come to him, and he may experience a renovation and a recuperation that can only be explained as the *after* effects of his vacation.

It is, perhaps, not so well recognized that tonic remedies, and systems of treatment of various kinds, may act just in the same way. Not only the evil but the good effects of medicines may be cumulative. We may see this principle illustrated in the administration of quinine, strychnine, arsenic, phosphorus, and iron.

Electricity obeys the same law, and in certain constitutions, and certain states of the system, especially those of debility, it does little or nothing that the patient can see or feel during the treatment itself,—but prepares the way for a perfect and permanent recovery. We have seen this principle illustrated in a large variety of cases of chronic disease. The practical lesson that we are to derive from this is to encourage patients who do not feel fully satisfied with the progress that they make while under treatment, to watch closely, if possible, their career long after treatment is abandoned.

*Electrization in its Relations to other Forms of Treatment.*—The question, so often asked, whether electrical treatment will interfere with internal medication, or with gymnastics, the Russian, Turkish or other baths, and so forth, is very easily answered. It harmonizes with all other tonic remedies, and methods of treatment that are employed for the common purpose of relieving pain, or building up broken-down constitutions.

Except in cases where we wish to experiment and learn the therapeutic value of electricity by itself alone, uncomplicated with other healing factors, it is a positive advantage oftentimes to employ, at the *same time* with electricity, external or internal medication of various kinds. So far as we now know there is no medicine that is incompatible with electricity. There is no evidence that any remedy has any



specific reënforcing effect upon electricity, such, for example, as certain stimulants have on hydrate of chloral. Some of the best therapeutical results are obtained from a combination of electrical with other treatment.

*On the Use of Electricity by the Laity.*—Even at this advanced stage of electro-therapeutics, it seems to be necessary to constantly warn the profession against indiscriminately intrusting the details of electrical applications to the nurses, friends of patients, and the patients themselves. Having just rescued this department from the hands of the laity, and given it a position among men of science, it seems strange that those physicians who are familiar with the subject should even now use their influence to return it to the people at whose hands it formerly suffered so much ; to restore it to the captivity of prejudice and ignorance.

The temptation on the part of the people to use electricity themselves, and on the part of the profession to allow them to do so, is very strong. The majority of physicians know little more of electro-therapeutics than their patients. Some have a theoretical, but not a practical acquaintance with it. Then there are those who are well practised in the art, but are too closely occupied to employ it. They have no apparatus, or if they have any it is very likely out of order. Perhaps no specialist is accessible, or the patient is, or is supposed to be, too poor to employ one. The physician, forgetting that it is not electricity, but electrization that cures disease, forgetting that there are two kinds of electricity in common use, and six different methods of application, every one of which is capable of various modifications, forgetting that there are certain temperaments that will not bear electricity, however applied, and that there are others who must be treated at first with great skill and caution, and on whom the currents and methods employed must be studiously varied during a course of treatment, in short, forgetting that electro-therapeutics, considered as a science or an art, is wonderfully complex and exacting, orders the patient to "*get a battery and try electricity.*"

This prescription is usually carried out in the following manner : An old magneto-electric machine (rotary) is trumped up from some neighbor's garret, where, after having failed to cure any member of the family, it has been rusting for years. If the patient be wealthy, perhaps a new faradic machine is ordered, that gives a harsh, rough current, and when applied, drives the patient to despair. The friends of the patient are bored with the request of the patient to apply electricity, and only half do their duty ; consequently the patient tries to make the application

to himself, and, of necessity, makes awkward work. Pretty soon the metals become corroded, and the current ceases to flow, and the battery is soon consigned to the closet or garret, where it will do no harm, and probably as much good as in the hands of the patient.

This picture is not drawn from fancy ; it is a picture of genuine and frequent experience.

*Abbreviations used in Electro-Therapeutics.*—It is a decided convenience and saves much time in recording cases, in giving private instruction, in public lecturing, and in conversation, to describe electrical applications by abbreviations. About a year since we devised the following abbreviations, which have been used with satisfaction in giving private instruction and in conversation with our assistants and others who are familiar with it, and in records of cases from day to day. We do not adopt it in the present treatise, for the reason that it is not yet widely known, and might perplex and bewilder the reader :

- L. F. Localized faradization.
- L. G.       “     galvanization.
- G. F. General faradization.
- C. G. Central galvanization.
- G. B. Galvanization of the brain.
- G. C. S.       “     “     sympathetic.
- G. S.         “     “     spine.
- E. Electrolysis.
- G. C. Galvar.o-cautery.

## CHAPTER IV.

### COMPARATIVE VALUE OF THE GALVANIC AND FARADIC CURRENTS.

MUCH of the confusion that exists concerning the differential indications for the use of the galvanic and faradic currents arises from an imperfect or erroneous or exaggerated conception of the distinction in their physical and physiological effects. The general belief or supposition is, that there is between them a radical and important difference in *kind*, as though they were two different agents or forces.

We can most intelligently compare the therapeutical effects of the two currents, if we first compare their physical characteristics and their physiological effects.

By referring to the section on electro-physics, it will be seen that both currents—faradic and galvanic—are capable of producing chemical decomposition, of deflecting the needle of the galvanometer, of producing sparks, and of being changed into heat. Generally speaking, these effects are produced more powerfully by the galvanic current; but in Gramme's machines we shall see that magneto-electricity is capable of producing great heat and of electroplating on an enormous scale.

Both currents are obedient to the law of Ohm, with this qualification, that the faradic current must be regarded as having passed through a great resistance.

Faradic and galvanic electricity are therefore the same force—electricity, only each variety is modified by the nature of the substance through which it circulates, as well as the manner of its production.

Light is light, whether its waves are shorter or longer, and in spite of interference and polarization, and whatever may be the color that it excites in the retina; sound is sound, whether its undulations move slowly or rapidly. So electricity is electricity, however generated or however modified by the medium through which it moves; and all forms of it, magnetism, as well as franklinism, galvanism, and the many varieties of faradism, are merely different expressions of the one great force—electricity.

In their *physiological* effects the two currents approach each other even more closely. It is true that the phenomena of electrotonos have only been demonstrated under the galvanic current ; but it is not proved that similar phenomena, to a less degree, may not be caused by the faradic current, and every-day experience in electro-therapeutics shows that with the faradic current, as with the galvanic, the positive pole is the more calming, and the negative the more irritating. Both currents act on the skin so as to modify the circulation, the galvanic having a greater chemical effect and causing a feeling of burning, while the faradic causes a feeling of stinging and pricking. Both currents applied to the brain and spinal cord excite contractions of peripheral muscles. Applied to the sympathetic both currents, according to the degree of irritation, cause contraction or dilatation of the cerebral vessels ; the faradic producing the same effect as the galvanic, only more slowly. Applied to the pneumogastric, whether cut or injured, both currents produce about the same effects on the heart. Even in their action on the nerves of special sense the currents approach each other far more closely than has been supposed.

In temperaments of a high order of susceptibility the faradic current may so excite the retina as to cause flashes before the eyes, and may produce a metallic taste in the mouth, and even the auditory nerve responds to the faradic current, though less distinctly than to the galvanic current, and without the peculiar differential action of the poles.

Applied to motor and sensory nerve branches, both currents and both poles cause sensations of pricking, tingling and numbness, and contractions of the muscles which the nerve supplies. Applied to voluntary muscles both currents cause contractions, the faradic more readily than the galvanic ; applied to involuntary muscles both currents cause slow contraction at both poles and in the intermediate region. The electrolytic action of the faradic current on the blood or on the tissues of the body is but feeble as compared with that of the galvanic current ; but yet it exists, and from the inner, or primary coil, is easy of demonstration ; and yet it must be confessed that in their chemical action the currents diverge more widely than in any other physiological effect.

Over nutrition both currents and both poles have a powerful influence, the faradic acting more prominently through the muscular, the galvanic through the nervous system.

From the accumulating results of experiments and experience in electro-diagnosis and therapeutics, we think that there is strong reason for regarding the essential distinction in the effects of these currents on

the body as mainly of *degree*,—practically amounting, it is true, to a difference in kind,—and that this is the scientific basis for their differential employment.

In the form of localized electrization both can produce muscular contractions in paralyzed muscles, and relieve local neuralgias; both cause absorption of abnormal secretions; and both can directly affect the brain, spinal cord, sympathetic, and all the internal organs, producing, in different degrees, the various therapeutic results that directly and indirectly flow from electrical excitation of these parts. In the form of general electrization both currents, besides producing most of the other results of localized electrization, act as powerfully stimulating tonics, and thus form most efficient aids in the relief and cure of nervous exhaustion, nervous dyspepsia, constitutional neuralgia, and of a wide range of nervous diseases associated with or dependent on general debility.

In electro-surgery both currents avail to discuss tumors, heal ulcers, and hasten absorption, although for these purposes the galvanic is incomparably the more effective.

And yet the difference in degree between the effects of the two currents is so marked and so clearly demonstrable, as to be practically equivalent in certain instances to a difference in kind, and to give very important and remarkable advantages to one current or the other, according to the indications required.

The advantages of the galvanic over the faradic are :—

1. *A greater power of overcoming resistance.* It therefore affects the brain, spinal cord, and sympathetic more powerfully than the faradic, since the anatomical position of these parts is such that considerable resistance must be overcome in order to directly affect them. For the same reason it is usually to be preferred when it is desired to affect the middle and internal ear, the retina, and the muscles of the eye.

2. *A power of producing muscular contractions in cases where the faradic fails.* This peculiarity of the galvanic current has now been observed so frequently, and in such striking instances, that it has become an accepted fact of electro-therapeutical science. Illustrative examples will be given in the section on paralysis. After a certain amount of treatment by the galvanic current the paralyzed muscles frequently resume their susceptibility to the faradic.

3. *A far more potent electrotonic, electrolytic, and thermic action.* The chemical power of the galvanic current is most markedly seen when used for the purposes of galvano-cautery or electrolysis. The superior efficacy of the galvanic current to the faradic, so often

observed in the treatment of neuralgia, of atrophied muscles, rheumatism, is probably due to its greater "catalytic" action. It probably induces more rapid and more important molecular and other changes in the tissues. This superiority of the galvanic current is supposed to be due to its more *continuous duration*; it moves constantly in one direction, and thus produces more powerful electrolytic effects than the faradic current with its rapid interruptions can possibly produce.

The advantages of the faradic over the galvanic current are these :—

1. *By virtue of its frequent interruptions it more easily produces muscular contractions when passed over the muscles or the nerves that supply them.* In order to produce full muscular contractions with a galvanic current of moderate strength it is necessary to interrupt the current, and, unless it is quite powerful, to localize at least one of the electrodes over the motor nerve by which the muscle is supplied—that is, over the so-called "motor points." On the contrary, the faradic current is in a condition of rapid interruption and produces contractions when indifferently passed over the surface of the muscle, as well as when localized on the main motor nerve that supplies it.

This advantage of the faradic current is best appreciated in general faradization, the powerful tonic effects of which, as will be seen, are partly and quite largely due to the passive exercise and consequent oxidation and other important changes of tissue that result from the several thousand muscular contractions that take place during an ordinary sitting. In localized electrization this advantage is not so clearly and strongly marked, since, in this method, by a proper knowledge of electro-therapeutical anatomy and sufficient care, it is possible to direct one of the electrodes on the "motor points;" and yet even here the faradic current is much more convenient, because its employment requires no arrangement for interruption, and less minuteness of attention to the situation of the motor nerves. The exceptional cases of paralysis, where the muscles have lost their susceptibility to the faradic current, do not interfere with the general rule.

2. *It produces greater mechanical effects.* These mechanical effects of the faradic current are due to its rapid interruptions, which cause contractions not only of the muscles, but also of the contractile fibre-cells, thus stimulating the circulation, and with it the processes of waste and repair. In this respect its action is similar to that of rubbing, pounding, movements and vibrations. These mechanical effects are especially indicated in the treatment of diseases of the abdominal viscera, which are supplied with contractile fibre-cells; **anæsthesia, and general muscular debility.**

3. *It is less likely to produce unpleasant or harmful effects, when incautiously used, than the galvanic.*

To confirm this statement we rest mainly on the evident results of clinical observation. We may indeed refer to a number of cases of severe constitutional neuralgia and excessive nervous exhaustion where the faradic current invariably relieved, and where the galvanic current as invariably aggravated, the symptoms. For this reason it is better to begin the practice of electro-therapeutics with the faradic current, and for those families who desire a scientific plaything, the faradic machine is safer than the galvanic apparatus.

In all applications to the head, neck, and spine especially, applications of the galvanic current can rarely be protracted without injury, while in many cases the spine and neck may be faradized through very prolonged sittings, with positive benefit to the patient. To the head, also, a faradic current of a proper quality may be applied much longer than a galvanic current, before unpleasant dizziness or headache is excited. The belief, pretty generally entertained in Europe, that the faradic current cannot be applied to the head without injury, is to be accounted for by the fact that most of the electric machines there employed are separate-coil machines, and do not furnish a current of sufficient smoothness for faradization of the head. Most of those who attempt this method of treatment use too small electrodes, and thus give the current greater density than the brain can bear. Galvanization of the eye or ear, or of the cervical sympathetic, must always be shorter than faradization of the same parts. These considerations, however, need not interfere with the use of the galvanic current to these parts, in all cases where it offers a positive advantage over the faradic. There is no real danger in using either current on any patient, provided it be used properly.

A consideration of some practical importance with general practitioners is, that the faradic apparatus is more convenient, more portable, than even the compactest galvanic apparatus that has yet been devised. It is impossible, however, for any practitioner to realize anything like the full benefit of electrization without apparatus for the galvanic as well as the faradic current.

The *general* differential indications for the use of the two currents may be thus summed up. The galvanic should be used—

1. *To act with SPECIAL ELECTROTONIC AND ELECTROLYTIC POWER on the brain, spinal cord, sympathetic, or any part of the central or peripheral nervous system.*

2. *To produce contractions in paralyzed muscles that fail to respond to the faradic.*

3. *In electro-surgery, to produce electrolysis or cauterization.*

The faradic should be used—

1. *To act MILDLY on the brain, spinal cord, sympathetic, or any part of the central or peripheral nervous system.*

2. *To excite muscular contractions wherever the muscles are not so much diseased as to be unable to respond to it.*

3. *To produce strong mechanical effects.*

Both are essential in electro-diagnosis—the faradic especially for the muscles, and the galvanic especially for the nervous system; and both are adapted for general as well as localized electrization, although in general electrization the faradic current is chiefly used. It logically follows from what has been said that very many—perhaps the majority—of diseases are best treated not by one current exclusively, but by both currents, either in alternation or succession. Special indications will be given under the special diseases.

*The two currents compared to bromide of potassium and hydrate of chloral.*

We are accustomed to compare in a rough way the differential action of the currents with the differential action of bromide of potassium and hydrate of chloral, the faradic current being the bromide of potassium, and the galvanic the hydrate of chloral.

Bromide of potassium is a safer remedy than hydrate of chloral, but there are very many cases where it is powerless, and the hydrate of chloral acts as a specific; so the faradic current is safer than the galvanic, and therefore better adapted for general use, and, for those who use but one current, fulfils a larger requirement; and yet there are many cases where it fails and the more powerful galvanic is demanded. Except for the cases where the galvanic current is clearly indicated, it is well to begin with the faradic current, just as we use bromide of potassium before resorting to hydrate of chloral.

A combination of bromide of potassium and hydrate of chloral is frequently more effective in producing sleep and relieving pain than either remedy when used alone: similarly the combined or alternate use of the faradic or galvanic currents will sometimes accomplish much more than either current used exclusively.

## GALVANO-FARADIZATION.

In order to secure the advantages of both currents, and at the same time to avoid the trouble and inconvenience of employing them in succession, or alternately, as is so frequently necessary, we have devised a



method of using them *simultaneously*. To this method we have given a name which sufficiently expresses its character—*galvano-faradization*. It may be either general or localized.

The method of general galvano-faradization requires a double electrode, with one part for the galvanic and the other for the faradic current. The copper plate may be connected at one part with the pole of the faradic, and at another with that of the galvanic apparatus; thus the circuit is completed for both currents.

In localized galvano-faradization it is necessary to have in use two double electrodes; for this purpose the double excitors of Duchenne answer very well. By a proper construction and adjustment of the electrodes it is possible to localize the two currents very near to each other. Whether any special therapeutical advantage arises from the simultaneous use of the two currents, we are unable to state.

We allow the above description of galvano-faradization to stand just as it appeared in the first edition.

Since we have used central galvanization—a method to be subsequently described—we have dispensed almost entirely with general galvano-faradization.

## CHAPTER V.

### THE PRINCIPLES OF ELECTRO-DIAGNOSIS (ELECTRO-PATHOLOGY).

IN this chapter we shall speak only of the *principles* on which electricity is used as a means of diagnosis in medicine. The details and special applications of these principles will appear under the various diseases.

A history of the use of electricity as a means of diagnosis would very likely be the history of electro-therapeutics itself. As soon as men began to use the voltaic pile in the treatment of paralysis and kindred diseases, about the middle of the last century, just so soon, probably, they began to test the power of the electric current to diagnosticate disease. We logically infer that electrization was used as a means of diagnosis much earlier than the published treatises on the subject would show, from the fact that it has been so used—in a blind and empirical way, it is true—in this country, for thirty or forty years. Mankind, always and everywhere, are superstitious, credulous, ready to receive whatever approaches them with an air of mystery, much more so in the last century than in the present; and it is certainly not unfair to suppose that the earlier experimenters in this department consulted, to a greater or less extent, the diagnostic or prophetic power of the subtle agent—electricity. Their experiments, we may suppose, were unscientific and unsatisfactory. They were probably neither based on any well-defined principles, nor conducted by any intelligible system. Accordingly, they secured very few tangible, or at least communicable, results, and if scientific men had not espoused the cause of electro-therapeutics, the phrase electricity as a means of diagnosis, would never have been known. Nearly all that has been accomplished in a scientific way, in this department, is comparatively recent; though Marshall Hall earnestly called the professional attention to the fact that Electricity might assist us in differentially diagnosing paralysis as far back as 1839.\* Since that time the subject has been studied by nearly all the prominent workers in the department of electro-therapeutics.

\* Medico-Chirurgical Transactions, 1839.

In order to be expert in electro-diagnosis, it is necessary to be thoroughly familiar with the normal reaction of the different parts and organs of the body to faradic and galvanic electricity. The foundation principles, on which Electricity can be made a means of diagnosis of disease, are simply these four :—

*First. The fact that all the parts and organs of the body are more or less sensitive to the electric current, and that this sensitiveness is modified by disease.* This electro-sensibility may be either increased or diminished.

If an electric current be passed through a boil, or irritable ulcer, or the skin, like any other irritant, it excites more pain than when it is applied over the healthy skin ; and this pain which it causes usually bears quite a direct proportion to the nature and condition of the morbid process. This is so familiar and so apparent an example of increase of electro-sensibility, that to state it is to demonstrate it. The electric currents, during the various processes of electrization, penetrate beneath the skin, and, as it has been experimentally and practically demonstrated, traverse, to a greater or less extent, the principal vital organs. It is evident, therefore, that those organs which are abnormally sensitive, through disease of any kind, must feel the current much more appreciably than when in a condition of health.

But the mechanical effects of the electric currents work both ways, and organs which are indurated or changed into an anæsthetic condition by disease are less sensitive than is normal to the electric current, just as they are less sensitive to any other mechanical cause acting upon them.

Accordingly, we find that when even powerful electric currents are passed through an indurated joint, or an atrophied liver, or any part the sensory nerves of which are paralyzed, they may produce little sensation.

Before making examinations to determine the sensitiveness of the different parts of the surface of the body, it is necessary to know their relative normal sensitiveness, as indicated and described in the chapter on Electro-Therapeutical Anatomy.

*No absolute Standard of Electro-sensibility.*—We have no absolute or mathematical standard of electro-sensibility by which to compare the deviations that appear in disease. We can only compare the sensitiveness of parts with the average sensitiveness of the same parts in health. When half the body is diseased, as in hemiplegia, it may readily be compared with the electro-sensibility of the healthy side. In all these examinations into sensibility we are dependent on the

statements of the patient, and the results will be influenced by his intelligence and honesty.

It need hardly be said that the diagnosis obtained by observing this increased or diminished sensitiveness, of any part or organ, must, of necessity, be a very general one. It simply informs us of, and directs our attention to, the fact that such a part or organ is in some way diseased. The special nature of this disease must be determined by the ordinary means of differential diagnosis at our command.

This sensitiveness to the electric current is particularly marked over the prominent nerve-tracts, and in those regions endowed with great tactile sensibility. If even a mild current be applied at those points on the upper or lower limbs where the prominent nerves are superficial, a feeling of tingling or numbness is felt through the branches of the affected nerve; and if the current is very much increased in strength, a decidedly anæsthetic effect is experienced. In paralysis of sensation, or anæsthesia, this feeling of tingling, thrill, and numbness is very much diminished under the influence of the electric current, or is entirely absent. It is on this principle that electricity becomes a most valuable means of diagnosis in the various stages of anæsthesia. A condition of anæsthesia or analgesia (loss of sense of pain) can readily be detected by the brass ball employed in general faradization, or by the metallic brush, or by any other form of electrode. To detect analgesia the electrode should be moistened so that the current may penetrate the epidermis.

General faradization is found to be of practical utility in aiding us to determine the locality of certain diseases, if not their precise nature. In dyspepsia, electrization often reveals great sensitiveness in the epigastric region, and on the left side over the spleen. In severe dyspepsia, accompanied by emaciation, a current is sometimes painfully transmitted from the middle of the back to the neighborhood of the epigastrium. A peculiar sinking sensation is sometimes felt at the pit of the stomach when a strong current is applied over the seventh cervical vertebra, or over the brachial plexus. All these symptoms, taken together, undoubtedly suggest an aggravated case of dyspepsia, and usually of the nervous variety. Congested or irritable states of the liver are revealed by an abnormal and peculiar sensitiveness when the current is applied over the right hypochondriac region. *Care must be taken, however, not to confound the normal sensitiveness of the superficial nerves over the ribs, with an abnormal condition of the liver.* There are certain diseases of this organ in which it is less sensitive than usual to electrization, and sometimes it appears to be decidedly anæsthetic.

A lady patient of ours who had suffered for years from hepatic disorder was very sensitive to the current excepting over the right hypochondriac region, where she could bear the whole power of the apparatus without any discomfort, except that which was necessarily caused by the natural tenderness of the skin. The precise condition of the liver at that time we were not able to ascertain. The evidence, however, was sufficient to confirm our previous suspicions in regard to the existence of some affection of that organ. It may be said in general, that those diseases which cause the liver to be sensitive to external pressure, also cause it to be sensitive to electrization. The same general principle will apply to the stomach, the spleen, the intestines, and the ovaries. Our experience in the electrical treatment of diseases of the lungs has not been large, but it has been sufficient to make it quite probable that certain sensitive conditions of tuberculous deposit may be suggested by abnormal sensitiveness to the faradic current over the apex of the chest.

Electro-diagnosis of the sensory nerves requires us to examine the condition not only of the various portions of the skin, but also of the nerve-branches, and the plexuses.

If in cutaneous anæsthesia we find normal sensitiveness on the nerve-branches, we judge that the disease is confined to the nerve ramifications only.

If in complete anæsthesia of an extremity the nerve plexus exhibits a normal reaction, we also judge that the disease is not central but peripheral, including the nerve-branches.

*For the purpose of testing the condition of sensation the faradic current is usually to be preferred,* for the reason that its mechanical effects are greater than those of the galvanic.

The electro-sensibility may be normal or nearly so when ordinary sensibility is much diminished. In some cases of posterior spinal sclerosis, for example, a moderate electric current may be fully perceptible while a pin may be thrust into the flesh without causing any pain.

*The Head.*—In health the head is very sensitive both to galvanization and faradization, in all parts except the posterior. This electro-sensitiveness of the frontal and parietal regions of the head is due to the superficial nerves, and not to the brain itself. In pathological cases this sensitiveness may be either increased or diminished.

*Spine.*—In health the spine is but little sensitive to the current. In pathological cases it may exhibit a sensitiveness to the electric current that is not revealed by pressure or by any other method of irritation. This condition is found in neuralgia, spinal irritation, hysteria, etc. It

is interesting, also, to know that electric examination sometimes indicates abnormalities in the sensitiveness of certain parts of the body that exhibit no functional derangement.\*

*Sympathetic and Pneumogastric.*—The ganglia of the cervical sympathetic and the pneumogastric may be examined electrically by the inner border of the sterno-cleido-mastoid muscle. Sometimes there is abnormal sensitiveness all along the border of the sterno-cleido-mastoid muscle in the track of the pneumogastric. This sensitiveness is found in a large number of pathological conditions, locomotor ataxia, muscular atrophy, various cerebral affections, etc. We have observed it also in spinal irritation, and during paroxysms of sick headache. This abnormal sensitiveness may be frequently demonstrated by mechanical pressure. We are disposed to regard this sensitiveness as due to the pneumogastric more than to the sympathetic.

*Electro-muscular Sensibility.*—Electro-muscular sensibility includes a feeling of pain and a feeling of contraction. The latter may exist without the former.

Success in investigating electro-muscular sensibility depends on the condition and intelligence of the patient.

In conditions of cutaneous hyperæsthesia it is exceedingly difficult, even for the most intelligent patient, to distinguish between the sensitiveness of the skin and that of the muscle.

In paralysis electro-muscular sensibility is frequently diminished, together with the electro-muscular contractility; they often rise and fall together. In hysteria, electro-muscular sensibility to pain is sometimes greatly increased. For remarks on the physiological nature of electro-muscular sensibility, see *Electro-Physiology*, p. 148.

*Secondly. The fact that the electro-muscular contractility and irritability are more or less modified by disease.*

*Irritability* strictly refers to the quivering which muscles exhibit under mild currents; *contractility* to the power of actually contracting under whatever strength of current may be necessary. The two terms are very frequently used interchangeably.

That muscular contractions can be produced by the electric currents, has been known since the period of the earliest investigations in the department of electro-physiology.

The first systematic attempts to make this a basis for establishing differential diagnosis were made by Dr. Marshall Hall, and subsequently by Dr. Todd. The conclusions of these distinguished experimenters are quite familiar, and as they were unsatisfactory and partly erroneous,

\* Benedikt op. cit., p. 60.

it is not necessary to present them in detail. More recent investigations have established that the behavior of the deep-seated muscles, in regard to their contractility, is a much more complicated question than was formerly supposed. The contractile power of a muscle is made up of two factors, viz.: the excitability of the intra-muscular nerve-fibres, and the functional capacity or irritability of the muscular substance itself. When, therefore, the contractile power of a muscle differs in any respect from the normal, this variation may be due to an abnormal condition of either one or both of these factors. Still further, it is stated that when the excitability of the intra-muscular nerve-fibres and the irritability of the muscular substance are increased, yet if the former has suffered more than the latter, the contractile power may be diminished, and *vice versa*.

*In comparing healthy with diseased sides in paralysis, it is necessary to use not only the same strength of current, but also the same relative position and pressure of the electrodes.*

The general principles that have thus far been established, in regard to the relation of electro-muscular contractility to disease, are as follows :—

1st. In paralysis of motion, the electro-muscular contractility is sometimes normal, occasionally increased, and very frequently diminished.

*Increase* of electro-muscular contractility, or at least of irritability, may be observed in diseases of the brain, attended with irritative lesions, in certain spasmodic and hysterical affections, and occasionally in locomotor ataxia. *Diminution* of electro-muscular contractility is usually observed in grave lesions of the anterior columns of the spinal cord, and motor tract of the brain, in rheumatic paralysis, lead-palsy, in well-marked progressive muscular atrophy, and in paralysis from injury of a nerve in some part of its course.

2d. In certain central diseases, the electro-muscular contractility is at first normal or diminished, and afterwards increases with the progress of the disease, until it becomes greater than normal.

The length of time that is necessary to illustrate these variations depends on the nature of the disease. In chronic inflammations of the spinal cord, in effusions in the brain, causing hemiplegia, these variations may run through many weeks and months. In cases of hemiplegia also, these different conditions of the electro-muscular contractility may run in a circle; being sometimes normal, sometimes increased, and sometimes diminished (Benedikt). All these changes correspond, of course, to certain changes in the pathological condition of the

diseased brain. Just what this correspondence is in each case, cannot, in the present state of electro-pathological science, be well determined.

3d. The fact that certain forms of paralysis behave very differently under the faradic and the galvanic current. Muscles over which a faradic current can have no influence, may contract easily under a milder galvanic current than is necessary to produce contractions of the same muscles in health. Sometimes, as the paralyzed muscles recover, they regain their power of contracting under the faradic current, at the same time proportionately losing their contractility under the galvanic current. This law is most readily demonstrated in peripheral facial paralysis.

This fact, that in certain peripheral paralyzes *galvano-muscular contractility may remain after farado-muscular contractility is wholly lost*, was first pointed out by Baierlacher in 1859. His observations have since been confirmed by Schulz, Meyer,\* Althaus, Hammond, Radcliffe, Ziemssen,† Legros and Onimus,‡ ourselves,§ and other observers. (See section on peripheral paralysis.)

Some of the more specific principles on which electricity is used as a means of diagnosis in medicine may be thus stated. Although contractions occur only on closing or opening the current, yet we distinguish four kinds designated by the following abbreviations: 1st, C. C. C.; 2d, A. O. C.; 3d, A. C. C.; 4th, C. O. C.

The first is the *cathodal closure contraction*, and occurs when the cathode, or negative pole, is applied to the nerve or muscle, and the current closed.

The second, *anodal opening contraction*, occurs when the anode or positive pole is applied to the nerve or muscle and the circuit opened.

The third, *anodal closure contraction*, occurs when the anode is applied and the current closed.

The fourth, *cathodal opening contraction*, occurs when the cathode is applied and the current opened.

The readiness with which these various contractions are induced relatively to each other, depends altogether upon the strength of the current and the condition of the nerves, whether diseased or healthy. If on the healthy nerve or muscle the negative pole is pressed, and a current of sufficient strength employed, it will be found that on closing the circuit a contraction takes place. In order, however, to induce a contraction of the same vigor on opening the circuit, it is necessary

\* Op. cit., p. 417.

† Op. cit., p. 61.

‡ *Electricität in der Medicin*, 1866, p. 76.

§ *New York Medical Record*, 1868, p. 409.



that the strength of the current be increased. Each one can readily confirm this statement for himself, and by experimenting thoroughly it will be found that contraction in the healthy muscle occurs in the order just given.

In diseased conditions, however, this formula is subject to great variations. The readiness with which a muscle contracts to electrical influences may be increased. This occurs in certain cases of hemiplegia associated with an irritative lesion; and in the early stages of facial paralysis due to the action of cold associated with a rheumatic diathesis. In these cases the intra-muscular nerves are attacked from the beginning, while there is but little if any alteration of the muscular fibres. The faradic current causes contractions through the intra-muscular nerves; therefore, in cases such as the above, its power to produce muscular contractility is lost. The galvanic current, acting more especially on the muscular fibres, retains its power, and, as experience shows, a milder current will cause contractions than is found necessary for the healthy muscle. As the patient improves, it takes an increased tension of galvanism to cause the same effects, until, finally, farado-muscular contractility becomes manifest. Again, the readiness of contraction may be decreased and finally abolished, as in the late stages of bulbar paralysis; occasionally in paralysis following acute diseases, in myelitis, and in progressive muscular atrophy.

The above are termed *quantitative reactions*, consisting, as has been stated, in a simple increase or diminution in the quickness of response to a current of given strength. Qualitative, which includes as well quantitative changes—in other words termed the *reaction of degeneration*—consist in an alteration in the order of occurrence of the contractions. These changes are observed in any form of traumatic paralysis where the continuity of the nerve has been completely interrupted, in rheumatic paralysis associated with compression at some point of the nerve, in lead palsy, many forms of infantile paralysis, in spinal paralysis where the gray matter is much involved, in progressive muscular atrophy, in some cases of neuritis, bulbar paralysis, in cases of pressure on the nerve by tumors or cicatrices, etc., and in some paralyses the result of acute diseases.

The normal formula becomes, in the above cases of paralysis, subject to the following changes: The negative pole at its closure (C. C. C.) becomes as weak or even weaker than the positive (A. C. C.), and the positive pole at its opening (A. O. C.) becomes weaker than the negative at *its* opening (C. O. C.). At the same time the contractions become weaker and less rapid than in health. When the circuit is closed

the contractions are also liable to become tetanic, while rapid interruptions of the galvanic current utterly fail to call forth any response.

*Volitional Contractility may exist when Electro-contractility is diminished.*—The volitional power may remain when the electric contractility is diminished. If a muscle exhibits diminution of contractility under electric irritation, but reacts normally to the *will*, the conclusion is that the muscle is not injured, but that the abnormality is caused by change in the irritability of the intra-muscular fibres. This is observed in certain stages of traumatic and lead paralysis. We arrive at the same conclusion in those cases where the muscles refuse to contract under direct, but respond normally to indirect, electrization.

Muscles of the eye are an exception to this rule, since, from their anatomical position, they cannot be made to contract by direct, but only by indirect, reflex action from the fifth pair.

Cases where reaction is lost both to the will and electricity indicate actual injury of the muscle.

Furthermore, it should be considered that the electro-muscular contractility and sensibility of diseased muscles may be and are greatly modified by the treatment, both permanently or temporarily. Modification may take place even during the séance.

*Thirdly.* That the special *physiological reactions of the central and peripheral nervous systems to the galvanic current are essentially changed when the nerve is in a pathological condition.*

This is true of the spinal cord, the motor and sensory nerves, spinal cord and nerves of special sense, and of the sympathetic. According to Benedikt, if the negative pole is placed, for example, on the peroneal nerve, and the positive on the patella, with an interrupted current, a weaker irritation appears than when the positive pole is placed on the cervical or lumbar vertebræ. The more the central parts are included in the circuit the greater the irritation. In pathological conditions this reaction is changed.

*Opening contractions* are regarded by Benedikt as characteristic evidences of certain forms of locomotor ataxy. They are observed also in neuritis and in *chorea minor*. They indicate a molecular disturbance. They accompany both increased and diminished irritability, usually the latter.\*

*Nerves of Special Sense.*—The changes of the reaction of the nerves of special sense to electric irritation may be both *quantitative* and *qualitative*.

\* These views of Benedikt, concerning the significance of "opening contractions," have been severely criticised by Brenner ("Untersuchungen," &c., Bd. ii., 1869, p. 215, et seq.).

*Auditory Nerve.*—It has been shown that the reaction of the auditory nerve to galvanic irritation—the strong subjective sensations of sound—is materially changed by disease; and by this we judge of the condition of the nerve. (See Diseases of the Ear.)

*Optic Nerve.*—The reaction of the optic nerve under the influence of the galvanic current, is attended with flashes of light. The qualitative changes in reactions of the optic nerve to electrical irritation are numerous. In certain pathological cases, as we have observed, flashes of light may be produced by the faradic current. In other pathological cases, as severe atrophy of the retina, the flashes of light do not appear during galvanization, or only when a very strong current is used. We have observed very marked differences in the reaction of the optic nerve in the two eyes when one was diseased and the other healthy. Flashes of light from galvanization of the lower part of the spine are indicative of abnormal irritability or organic disease of the spinal cord. They are observed in locomotor ataxia and spinal irritation.

*Olfactory and Gustatory Nerves.*—The peculiar smell that is experienced on galvanization of the olfactory nerve may be either increased or diminished by disease. It is absent in paralysis of the olfactory nerve.

The peculiar metallic taste that follows galvanization of the tongue, or that is experienced by reflex action when the galvanic current is applied on the neck and upper part of the spine, is subject to various modifications by disease. In irritable conditions of the cord we have observed that this metallic taste will appear when the application is made in the lower part of the spine. In two striking instances it was experienced from faradization of the *cilio-spinal* region.

*Fourth.* *The fact that in certain central diseases, and in conditions of great irritability, as hysteria, the reflex effect of the current is so exalted as to excite reactions that in a normal condition of the body never appear.* Thus, in a lady of middle life, who for several years had suffered from all the symptoms of declared chronic myelitis, we were first struck by the fact that even a very mild current over the upper portion of the back was sensitively felt down the right leg. This symptom we have never known to occur in a perfectly healthy condition of the spinal cord. Afterwards we found that a very short as well as very mild application of the current to one leg caused a disagreeable feeling of pain and heaviness not only in this leg, but also in the other, for several days following the application. In another case of general paralysis dependent on hysteria, a very feeble current localized in one

hand, or in one foot, would be appreciably, and oftentimes painfully, felt through all the four extremities. The patient declared that the sensation was like that of "waves rolling through the body."

A still more marked illustration of this diagnostic power of electrization was the following :

In the case of a lady whose lower limbs had been somewhat paralyzed for two years, who presented no marked symptoms of severe organic disease of the cord, we were inclined to suspect that her paraplegia might be due to nervous exhaustion, until this abnormal reflex sensitiveness to the electric current seemed to establish the existence of myelitis, or at least meningitis. We first observed that a feeble current in the neck was felt down the spine, and subsequently the patient complained that a strong current down the lower extremities transmitted pain to the back. The occurrence of this abnormal symptom forced us to the unwilling conclusion that we were dealing with a case of organic disease of the spine. The subsequent history of the case has confirmed this diagnosis. It has been shown by Benedikt,\* that, in certain morbid conditions, electrization of one extremity produces contractions in the other. This phenomenon has been observed in progressive muscular atrophy, and in certain reflex neuroses. In a case of rheumatic gout that we treated the application of the galvanic current to the left knee caused a sharp pain in the corresponding part of the right knee.

This fact enables us not only to make a diagnosis of central disease, but in certain cases even to suspect the seat of the affection.

We are confident that in all cases of crossed reflex contractions—just as in the cases of crossed reflex sensation above cited—there is always some central disease. This symptom when it occurs may perhaps then be regarded as so far forth diagnostic.

Crossed reflex sensations and crossed reflex contractions may be manifested simultaneously in a patient affected with organic disease of the spinal cord. This singular coincidence was observed in the case above recorded of the lady who complained of waves of sensation all over the body when the current was applied to any one of the four extremities. These peculiar sensations were sometimes accompanied by feeble and spasmodic muscular contractions.

General shaking and tremor of a limb, or of the whole body, after electrization, is also diagnostic of central disease. We have observed it in one case of softening of the brain, and in a number of cases of hemiplegia. This general or partial tremor does not appear unless a con-

\* Die Elektrotherapie, p. 63.

siderable strength of current has been employed, or the application has been much prolonged.

*Diplegic Contractions.*—Remak,\* of Berlin, was the first to note the fact, that contractions of the muscles of one or both of the upper extremities may sometimes be produced by placing the positive pole in the auriculo-maxillary fossa, just posterior to the ascending ramus of the lower jaw, and the negative by the side of the sixth cervical vertebra. The theory of Remak, that these contractions, to which he gave the name of "*diplegic*," were caused by irritation of the superior ganglia of the sympathetic, was apparently confirmed by Fieber,† by experiments on animals in whom the sympathetic was exposed, and subjected to the action of the current.

Strong currents—from twenty to forty elements—are usually, though not always, necessary to produce these contractions. The contractions may be of various degrees, from mild drawing, with scarcely perceptible oscillations, to violent movements resembling chorea. They may appear in the interossei or in the muscles of the arm or forearm of one or both sides. They may also appear in other positions of the electrode than the one described. From one to five minutes are usually necessary to excite them, and they may continue for a few moments after the application has ceased.

That these so-called diplegic contractions are a reality and not a delusion, as some have declared, we have demonstrated in a number of cases, and especially in progressive muscular atrophy. The cases where they are readily demonstrated, are, according to our observation, not frequent, and we can easily see that one might practise electro-therapeutics for a long time without seeing any, especially as currents of considerable strength, applied in a certain manner, are necessary to produce them.

The evidence that these contractions occur exclusively through the sympathetic is not to our view satisfactory, and there is stronger probability that the spinal cord is the centre, which in certain irritable conditions exhibits these manifestations under strong electrical stimulation. In none of the methods of application where these diplegic contractions are called forth is it possible to localize the current in the sympathetic. The special diagnostic value of these contractions is not great. They occur not only in progressive muscular atrophy, but in hysteria and hysteroid affections, and would appear to be pathogno-

\* Application du courant constant au traitement des neuroses. Paris, 1865.

† Die diplegischen Contraktionen nach Versuchen an Menschen und Thieren, Berlin, 1866, pp. 21, 22, 23.

monic of no one special disease, but rather of a condition of irritability of the nerve-centres that may appear in many different diseases.

*Feigned Diseases.*—By the application of the principles stated above the electric currents may be of great service in helping us to distinguish real from feigned disease. A case of pretended paralysis of motion or sensation can readily be settled by applying the current to the limb, since no force of will can fully resist the energy of the contractions that electricity may excite in healthy muscles, or the pain that can be produced by strong faradization of the skin. The principle will work both ways, and, if the electro-muscular contractility is diminished below the normal standard, we may know that the disease is real. Where one side or one limb only is affected, the comparison between the healthy portions and those where disease is suspected can easily be made. Dr. Russell Reynolds \* mentions a patient with hemiplegia who was supposed to be malingering. Electrization of the limbs on both sides showed clearly a diminution of contractility on one side, as the patient represented, and accordingly the case was pronounced to be one of real hemiplegia.

Dr. Althaus † records a case of suspected malingering that he studied by the aid of electricity. A member of a workmen's benefit society professed that he had lost the use of his arm in consequence of an accident—a fall—three years before. The question was whether the society should give him the £100 to which permanently incapacitated members are entitled. The patient, though tall and strong, had done no work since the accident, and professed to be unable to undress himself.

On examination with the faradic current, Dr. Althaus found that all the muscles of the arm responded without difficulty; he therefore concluded that the nerves and muscles were uninjured—in other words, that there was no paralysis. He found, however, that when a very strong current was used the patient appeared to suffer, but the arm did not execute the movements it should do when the muscles contract. Accordingly, he had the patient anæsthetized by nitrous oxide gas, in order to see whether any ankylosis existed that might interfere with the movements of the arm. It was found that no ankylosis existed. Dr. Althaus gave a certificate that the patient had no paralysis and no ankylosis or dislocation, but that there was a painful affection of the joint which would yield to subcutaneous injections of morphia and galvanism, and that the patient could use the arm if he wished to. The claim for benefit money was disallowed.

*Faradization as a means of distinguishing real from apparent death—*

\* Lancet, April 16, 1870.

† Third Edition, p. 455.

*Electro-Bioscopy.*—The use of electricity as a means of distinguishing real from apparent death was suggested as long ago as 1792, by Drs. Behrend and Creve. Subsequently Boer, of Vienna, used franklinic electricity on newly-born infants, and found that when muscular contractions still existed, then the child was not dead, but could be restored.

In 1852, Dr. Crimotel, of Paris, wrote a memoir in which he stated that when *farado-contractility* is gone, life is extinct. He stated furthermore that farado-contractility gradually disappears after death, and that after a period ranging between half an hour and two hours it entirely disappears. He suggested the term *electro-bioscopy*, and recommended that those who are apparently dead from drowning, syncope, apoplexy, freezing, hysteria, and the inhalation of poisonous gases, should, before burial, be tested.

Rosenthal, of Vienna, has also studied the subject with much care. He has found that both farado- and galvano-contractility gradually disappear after death. He agrees in the main with Crimotel in the following general conclusions :

*Electro-contractility disappears more rapidly after death from chronic than acute diseases ; it persists longer in well than in badly nourished bodies, and it usually disappears within three hours.*

Rosenthal found that in amputated limbs the farado- and galvano-contractility were active the first hour, and entirely disappeared in ninety minutes. In case of drowning electro-contractility disappeared in three hours and a quarter. In some cases where rigor mortis has not appeared, where the temperature of the body is yet quite high, and where the joints are flexible, the absence of electro-contractility yet proves beyond question that the person is dead.

Rosenthal further records a very remarkable case of trance in a hysterical woman, where it was declared and believed by the physician that the patient was dead. The skin was pale and cold ; the pupils contracted, and not sensitive to light ; no pulse could be felt ; the extremities were relaxed ; melted sealing-wax dropped on the skin caused no reflex movements, and no moisture appeared on a mirror held before the mouth. Respiratory murmurs could not be heard, but a feeble intermittent sound in the cardiac region was just perceptible on auscultation. For *thirty-two hours* the patient had been apparently dead ; but on electric examination Rosenthal found *farado-contractility* in the muscles both of the face and the extremities. He therefore urged the use of the faradic current to restore the patient. In twelve hours the patient recovered her speech and movements.

Two years afterwards she was alive and well, and informed Rosenthal that she knew nothing about the commencement of the attack of the trance, and that afterwards she heard people talk about her death, but she was powerless to help herself.



## CHAPTER VI.

### ELECTRO-THERAPEUTICAL ANATOMY.

*Electro-therapeutical anatomy includes a description of the localities at which the different nerves, muscles, and organs can be best affected by the electric currents, and also the relative electro-sensibility of the different parts of the body. It is therefore to electro-therapeutics what surgical anatomy is to surgery.*

*Motor Points of Muscles.*—The subject of the motor points was first systematically studied by Ziemssen, who experimented on the recently dead subject, and marked with nitrate of silver the points at which the individual nerves and muscles most readily responded to faradization. Many of these points can be easily and successfully studied on the living human subject. Those which we have represented in the cuts are derived mostly from numerous observations on persons in health. They have been found to agree in the main with those of Ziemssen, with which they have been compared, and by which they have been made more accurate and complete. Those who wish to examine the subject in greater detail are referred to the work of Ziemssen.\*

It will be found, however, that those which are here described are sufficient for most of the purposes of electro-therapeutics.

The best method of verifying these points is to place one large sponge electrode, well moistened, on some indifferent point, and to firmly press a small negative † electrode, also well moistened, over the spot where the nerve or muscle should be affected. If the right place is touched, and the strength of the current and the pressure be sufficient, the normal physiological action of the part affected will at once appear. In the case of muscles contraction will take place, accompanied with a feeling of contraction; in the case of nerve-branches and plexuses, there will be sensation more or less painful along the peripheral ramifications of the nerves, and, if the excitation be sufficiently strong, contraction of the muscles which they supply.

\* Die Electricität in der Medicin. Berlin, 1866. p. 154, et seq.

† The negative is to be preferred, because it is the stronger, and acts more powerfully in producing contractions.

It is not to be understood that a studious regard for all of these electric points is always necessary in making applications of electricity. In the normal condition most of the superficial and many of the deeper muscles and nerves are easily excited by ordinary labile applications with large sponge electrodes. Some of the muscles have two or more motor points, and are therefore more readily affected by large than by small electrodes.

A large sponge electrode of from 3 to 6 or 8 inches in diameter, folded over a brass ball, such as is used in general faradization,—causes full contraction of a majority of the superficial and deep muscles when rapidly passed up and down the limbs.

But when the muscles have become diseased, so that they respond with difficulty to the electric current, it becomes necessary to give special heed to the situation of these motor points, in order to determine their actual electric condition, or to aid in restoring them to their normal condition by exciting artificial contraction.

It should be remarked furthermore, that these motor points vary in different individuals, just as the anatomical relation of the nerves and muscles varies, and that the representations of the cuts can be only approximately correct.

The points at which the nerves and muscles of the eye, ear, and larynx can be best electrized, also the best method of electrizing the œsophagus, rectum, genital and abdominal organs, will be described in the chapters devoted to the diseases of those parts.

We present below a brief description of the points at which the principal nerves, plexuses, and branches can be best excited electrically, and also the physiological effect on the nerves and muscles produced by such excitation.

*Facial*—at its exit from the stylo-mastoid foramen, between the mastoid process and the angle of the lower jaw, or at the opening of the external auditory canal.

*Pneumogastric*—at the lower and anterior part of the neck, between the common carotid artery and the jugular vein; *inferior laryngeal*—between the œsophagus and the trachea by the ganglia of the sympathetic.

The *superior cervical* ganglion of the sympathetic can be reached in the anterior maxillary fossa, just behind and below the angle of the lower jaw; the *middle cervical*, by the side of the sterno-cleido-mastoid muscle, opposite the fifth cervical vertebra; the *inferior cervical*, also by the inner border of the sterno-cleido-mastoid muscle, opposite the second cervical and first dorsal vertebræ.

*Accessory*—at its exit from the sterno-cleido-mastoid muscle.

*Hypoglossus*—between the stylohyoid and hyoglossus muscles, under the hyoid bone.

*Phrenic*—at the outer border of the sterno-cleido-mastoid muscle, by the anterior border of the scalenus anticus, near the omohyoid muscle. Excitation of this nerve causes strong movements of the chest.

*Brachial plexus*—in the supra-clavicular space, posterior to the outer border of the sterno-cleido-mastoid muscle. Excitation of this plexus causes a feeling of tingling and numbness in the fingers and down the arm, and, when the current is strong, flexion of the forearm and fingers.

*Dorsalis scapulae*—at the border of the trapezius, near the accessory.

*Supra scapularis*—just before its entrance into the scapula, and external to the omohyoid muscle.

*Anterior thoracic*—at the upper border of the pectoralis major, below the clavicle.

*Posterior thoracic*—above the clavicle, near the trapezius.

The thoracic nerves are irregular in their distribution, and therefore difficult to find.

*Axillary*—at the upper and posterior border of the axilla.

*Musculo-cutaneous*—between the biceps and coraco-brachialis.

*Median*—in the lower third of the arm, at the point where it crosses the brachial artery. Mild excitation of this nerve causes tingling in the arm and fingers; a strong excitation causes closure of the fingers and pronation of the hand.

*Ulnar*—at the groove between the olecranon and the internal condyle. Excitation of this nerve causes pain in the inner surface of the forearm and contraction of the flexor carpi ulnaris, flexor digitorum profundus, adductor pollicis lumbricalis, and interossei of the little finger.

*Radial*—in the lower third of the arm, at the point of its emergence from beneath the triceps. Excitation of this nerve causes tingling in the outer part of the arm and forearm, and down to the wrist; strong excitation produces extension of the first phalanges of the fingers, extension of the hand and thumb and supination of the forearm, contractions of the extensor carpi radialis and ulnaris, extensor digitorum communis, extensor minimi digiti, extensor indicis prop., extensor pollicis longus and brevis, adductor pollicis.

*Sciatic*—in the thigh, posterior to the head of the femur, at the point where the nerves issue from the pelvis, or in the pelvis, through the posterior wall of the rectum. Electrization of this nerve causes sensa-

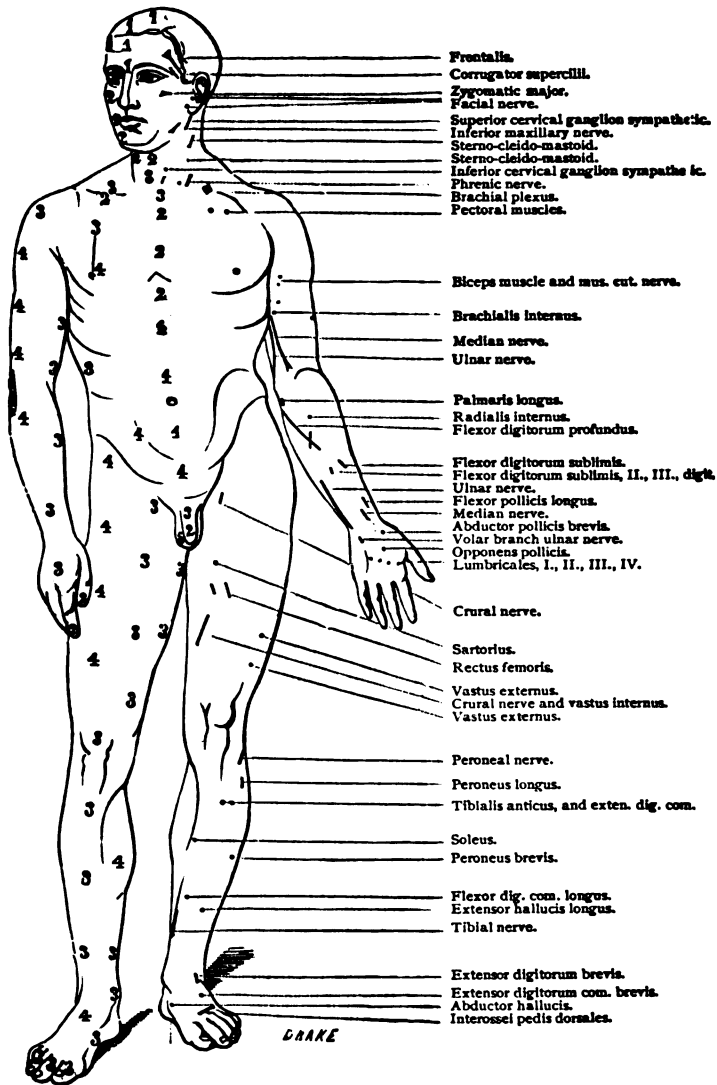

FIG. 42. Electro-therapeutical Anatomy of the Human Body. Anterior view.  
(For explanations see letter-press.)

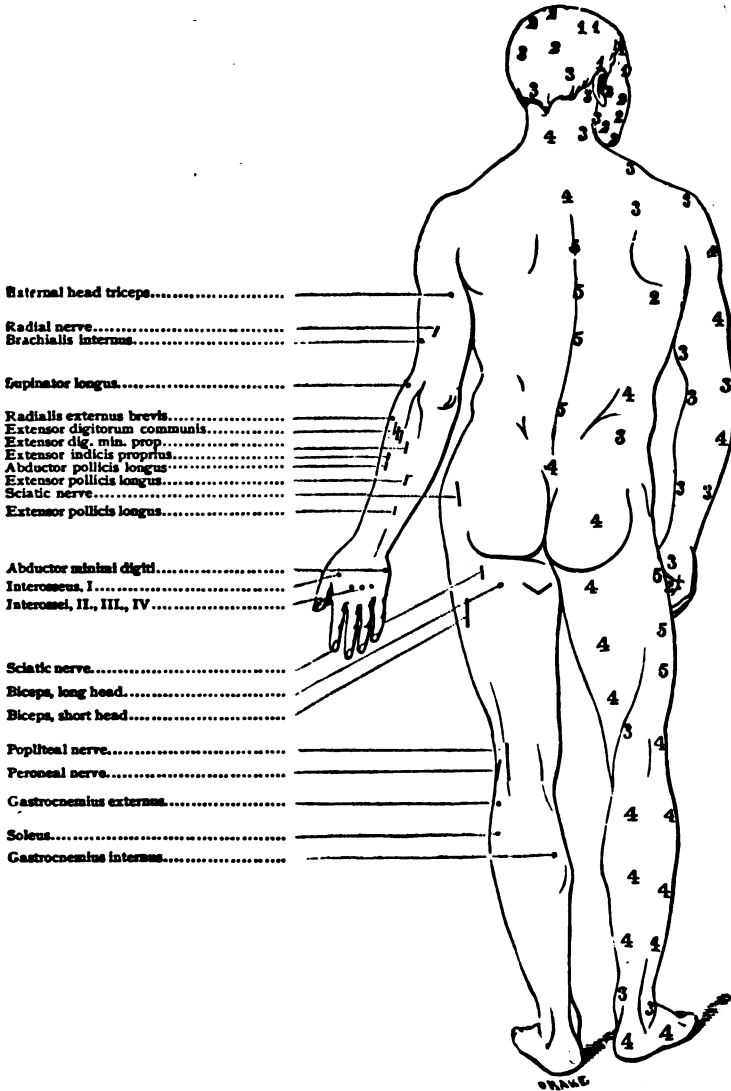

FIG 43. Electro-therapeutical Anatomy of the Human Body. Posterior view  
(For explanations see letter-press.)

tions of tingling in the leg below the knee, and foot, similar to those which we so often experience when we accidentally sit on the sciatic nerve.

*Crural*—just after its exit from beneath Poupart's ligament, exterior to the crural artery. Electrization of this nerve causes sensations in those parts of the leg that are supplied by its branches.

*Obturator*—on the horizontal branch of the pubic bone. If the application is successful, and the current used sufficiently strong, the thigh is abducted.

*Popliteal*—in the outer part of the popliteal space. Electrization of this nerve causes vigorous contraction of the muscles that move the foot upward and outward.

*Peroneal*—on the posterior border of the capitulum fibulæ. Excitation of this nerve causes contraction of the tibialis anticus, peronei muscles, extensor digitorum communis longus, extensor digitorum communis brevis, and extensor hallucis longus.

*Tibial*.—This can be reached on the middle and outer part of the knee. When strongly electrized, contractions arise in the muscle of the posterior part of the leg. The tibial nerve can more easily be reached in the depression posterior to the internal malleus.

*Farado-sensibility of the Surface of the Body*.—Very many muscles have no accessible motor points, and must therefore be electrized intramuscularly. Practically this is done in the majority of cases. We present in the accompanying cuts a bird's-eye view of the electric points of the prominent nerves, plexuses, and muscles, and of the relative sensitiveness of different parts of the surface of the body to the faradic current.

The relative sensitiveness of the different parts of the surface of the body to faradization, we have also ascertained by numerous comparative observations on persons in health, with the moistened hand and well-moistened sponge electrodes. The method of making these observations is to place the patient in the position for general faradization, with his feet on the plate to which the negative pole is attached, while the experimenter applies the positive all over the surface of the body.

*Degrees of Farado-sensibility*.—We have distinguished five degrees of sensitiveness, the highest being marked one. For all practical purposes these are sufficient; approximate accuracy is all that is attempted. The sensitiveness of the body when irritated by the faradic current is due partly to the quality and position of the sensory nerves, and partly to the peculiar feeling that attends muscular contraction (electro-muscular sensibility).

The feeling of muscular contraction amounts in some instances to actual pain, so that a part which is not richly supplied with sensory nerves may yet be very sensitive to the current. This is especially the case with the sterno-cleido-mastoid muscle, which on being touched near its centre contracts with a painful jerk. The same is true, to a less extent, of the trapezius, the flexors of the arm, and of the peronei muscles. In all parts where no muscular contractions are produced, the sensitiveness of the surface of the body depends on the quality and position of the sensory nerves, and bears a pretty constant relation to its sensitiveness to ordinary mechanical irritation.

Thus it will be observed that the parts which are most sensitive to a blow or fall, or to any mechanical injury,—as the head, face, or surface of the bones, clavicle, sternum, scapula, patella, etc.,—are likewise marked highest in the scale of sensitiveness to the current.

To guard against error it is necessary—

1. To use always the same electrode and the same direction of the current; therefore the negative pole should be kept at the feet during the entire sitting.

2. To make the pressure of the electrodes uniform, and to moisten well all parts supplied with hair.

3. To use the moistened hand for the head and face. The head, especially, is so exceedingly sensitive to the faradic current that it will hardly bear a sufficient strength of current through a sponge to make a comparative estimate.

It will be observed that only a few parts are marked 5—the middle of the back, the outer surface of the thigh, and the testicles. The perinæum, which cannot be represented in the cut, should also be marked 5. It will be observed that the points most highly sensitive are those where very sensitive nerves pass over the surfaces of bones, as the head and jaws. Of the other parts not represented in the figures, the external auditory canal should be marked 1; the middle of the sterno-cleido-mastoid muscle, 2; the axilla, 3; and the ends of all the fingers, 2; the under side of the penis, 2; the point between the penis and scrotum, 4; the under surface of the heel, the plantar arch, the ball of the foot, 4. If the external auditory canal, drum of the ear, conjunctiva, nasal mucous membrane, tongue, and larynx were represented, they should be marked a degree or two higher than 1, since they are more sensitive than any portion of the surface of the head. The best point to test a current of extreme feebleness is the tip of the tongue.

*The rectum, urethra, and vagina are but little sensitive to the current in comparison with the mucous membranes of the mouth, except at their*

external orifices. They might be marked 4 or 5. The os uteri and the bladder would be marked 4, 5.

It should be distinctly understood that these remarks apply to the applications of the faradic current with electrodes sufficiently moistened to allow the current to pass readily through the epidermis. In dry faradization the results are somewhat different, the pain at all parts being far less.

*Farado-sensibility as compared with Galvano-sensibility.*—The galvanic current causes a burning sensation wherever it is applied ; but this is most sensitively felt at those parts that are abundantly supplied by sensory nerves. This burning feeling increases with the length of time that the current is applied.

The greater sensitiveness of the bones to the faradic current, as compared with the galvanic current, is due to the greater mechanical action of the former. An interrupted galvanic current, of sufficient strength to produce muscular contractions, produces the same sensations as the faradic current, with the addition of the burning feeling at the surface beneath the electrodes. The fact that the galvanic current is less painful to the surfaces of the bones gives it a certain advantage in making applications to the head, although the pain of the faradic current, when applied to the head by the moistened hand, may be reduced to a minimum.

*A Knowledge of the Normal Electro-sensibility of the Body essential in Electro-diagnosis and Electro-therapeutics.*—A knowledge of the relative sensitiveness of the different parts of the body to the electric current is indispensable both in *electro-diagnosis* and *electro-therapeutics*. It is at once obvious that to determine by the electric test the extent of anæsthesia, or loss of electro-muscular sensibility, in cases of paralysis, without a previous knowledge of the normal sensitiveness of the parts to the electric current and the normal feeling of electro-muscular sensibility in the affected muscles, is simply impossible. From a want of this knowledge very important mistakes are made in electro-diagnosis. In local and general faradization a knowledge of the relative sensitiveness of all the parts of the surface of the body enables one to make an application which would otherwise be painful, and perhaps injurious, both painless and refreshing.



## CHAPTER VII.

### APPARATUS FOR ELECTRO-THERAPEUTICS.

**THE** general principles on which batteries are constructed, as well as minute description of some of the best known elements, have already been presented in the section on electro-physics. In this chapter we propose to speak only of those combinations of elements that are used in electro-therapeutics, and our descriptions will be of a general character, having reference mainly to the practical use and care of them by the electro-therapeutist.

Before entering on the description of apparatus a few general remarks may be appropriate.

1. A good battery is not all that is necessary to make a good electro-therapeutist.

There exists an impression, quite widely prevailing in the profession, that the beginning and the end of the great science of electro-therapeutics is to get a battery. This impression has wrought much evil. It has been the means of leading physicians to invest time and patience and money in a department for which they have no qualification. The purchase of a battery is simply a first step in the right direction; it is the beginning of a long road.

One who uses electricity in medicine requires good apparatus, just as the surgeon requires good instruments and the carpenter good tools; but as tools cannot make a carpenter, nor instruments a surgeon, so a battery cannot make one skilful in the therapeutical use of electricity. It is not the battery, it is the brains, that makes a good electro-therapeutist.

2. The best and most recent apparatus is not so simple as to entirely dispense with the need of care and experience on the part of the physician.

The advance in the construction of apparatus for electro-therapeutics has been very great, but not sufficient to make it possible for faradic or galvanic apparatus to keep in order without attention.

Just as the fire in the grate goes out unless the coal is replenished, just as the gas is extinguished when the supply is shut off, so electricity

generated in a battery ceases to flow unless the metals consumed in the chemical action are replaced or repaired.

The best and simplest of batteries will sometimes get out of order. Unexpected contingencies will arise that demand some knowledge of applied electro-physics. The knowledge can be obtained only by study and experience.

3. Whatever choice we make in our apparatus at the present day, we shall probably not make any very serious mistake. A few years ago it was impossible to get a really good apparatus for electro-therapeutics; now it is almost impossible to get a really bad one.

4. An apparatus to which we are accustomed is much more tractable in our hands than a far superior apparatus, the management of which is new to us. It is with batteries as with babies—every man thinks his own is the best. We see the same principle illustrated in instruments for general and special surgery.

*Continuous-coil and Separate-coil Faradic Machines.*—There are in the market, and in common use among physicians, two quite different forms of faradic apparatus. In one of these forms which we call the *continuous-coil* machine, the helix is composed of *one long wire varying in thickness, tapped at different points, so as to obtain different qualities of current.* This wire may be wound in three, four, or more coils. The inner coil is usually comparatively short, and is of thick wire; the second coil is longer, and of finer wire; the third still longer and finer, and so on; but the metallic connection is complete, and it is all a continuous wire.

The machines of Kidder, Hall, and others are of this construction.

In the *separate-coil* machines the helix is composed of two *entirely separate* and distinct wires; the inner wire, which like that of the inner coil of the continuous machine is short and thick, has no metallic connection with the outer wire. The outer wire is longer and thinner than the inner wire. The faradic machines of Stöhrer, of Drescher, and of the Galvano-Faradic Manufacturing Company are of this construction.

The quality of the induced current generated by these two types of machines are quite different. We have already seen (Electro-Physics, p. 2) that electricity is a force—a mode of motion of the ether and of the particles of the substance in which the force circulates. It follows from this definition—if we accept it—that the quality of the current must be modified by the nature of the substance through which it is conducted. Every modification of the conductor, increase or diminution of its diameter, increase or diminution of its length, or any change in its constitution, must affect more or less the character of the current that flows through it. Hence it is that the currents coming from the different points

of the continuous-coil machine are somewhat, though slightly, different from each other in quality and in their physiological effects. Hence also the current from the separate-coil machine is quite different from that coming from the continuous-coil machine.\*

*Single-coil and Separate-coil Faradic Machines compared in their Therapeutic Effects.*—The conclusions at which we have arrived on this question are formed from a very wide experience with single and separate machines, in public and private practice as well as from conversation and correspondence with many physicians who are using one or both varieties, and whom we have requested to study their comparative effects. Our conclusions may be thus stated :

1. For nervous, hysterical, and greatly debilitated patients, and in nearly all cases where general faradization is required, a single-coil machine is preferable.

This conclusion is based not on any physical, physiological, or theoretical considerations, but simply on *clinical experience*. Again and again have we attempted to treat nervous, delicate, and hysterical patients with the separate-coil machine, and have been compelled by unpleasant symptoms to return to the machine with a single coil. The reasons why the current from the single-coil machine is less irritating and more agreeable to delicate patients, are to be found in the *physical differences of the currents* already referred to. This conclusion is not peculiar to ourselves ; it is held by many, though not by all, the electro-therapists with whom we are acquainted.

It is not even necessary that the patient should be very delicate in order to test this difference ; any individual of average strength and health will appreciate without difficulty the general fact, that the current from the one machine is more agreeable and less harsh and wearying than the current from the other.

That the tonic and sedative effects of general faradization can, however, be obtained by separate-coil machines, is proved in Germany, where the faradic machines in use are chiefly of the separate-coil variety, and general faradization is used there continually by the highest authorities in electrology, and with all the brilliant effects over nutrition that we have in our writings claimed for it.

It must, however, be admitted that the Germans are much less sensitive and nervous than the Americans.

But the advantages of a smooth and pleasant current are not confined

\* Onimus, of Paris, has recently shown that helices formed of copper, silver, and lead have a differential physiological action.—*Four. de l'Anatomie et de la Physiologie*, Mars, 1874.

to general faradization ; in localized faradization of the muscles of the face, legs, and arms, and in applications to special organs that are irritable, the current from the separate-coil machine is more irritating and unpleasant than that of the single-coil machine. In children with infantile paralysis, and in delicate women who perhaps are afraid of electricity, this consideration becomes one of practical importance.

On the other hand, there are very many cases, especially in public practice, where it is a matter of apparent indifference which current is used.

2. For patients who from idiosyncrasy or from disease are greatly insensible to electricity, the separate-coil machine seems to be preferable to that of the single coil.

Cases are not very uncommon, even among the better classes, where there is enormous and inexplicable tolerance of electricity. Powerful and protracted applications leave them as they find them ; they are not painfully felt during the sitting, and they leave no appreciable effects behind them. In the anæsthesia that accompanies posterior spinal sclerosis and certain injuries of nerves, the harsh and irritating current of the separate-coil machine is not disagreeable at all, and appears to be, in our hands at least, more efficacious than the current from the single-coil machine. We are, we believe, the only observers who have called attention to this fact. Formerly we supposed that the difference in the quality of the current of different machines depended mainly on the construction of the rheotome ; this view is not sustained by our more recent studies in the department. It is the coil more than the rheotome, and more than the kind of cell, that determines the quality of the current, although the frequency of the vibrations as determined by the rheotome has a decided influence.

*The Comparative Value of Slow Interruptions.*—There are a large number of physicians who find or think they find a great therapeutical advantage in slow interruptions to the treatment of paralysis. A blind deference to authority has prevented a careful, original, and impartial investigation of this subject, and statements of European writers and instrument makers had been received without dispute, until we incidentally spoke of our experience in the matter less than two years ago.

*With a slow interruption a stronger current can be borne than with a rapid interruption,* and hence it sometimes happens that a paralyzed muscle will contract under the former when it will not under the latter. In occasional instances this advantage may be utilized for those physicians who have only the faradic and no galvanic apparatus.

For those who have a galvanic current of good strength the slow interruption is unnecessary, even granted that it has some advantage over

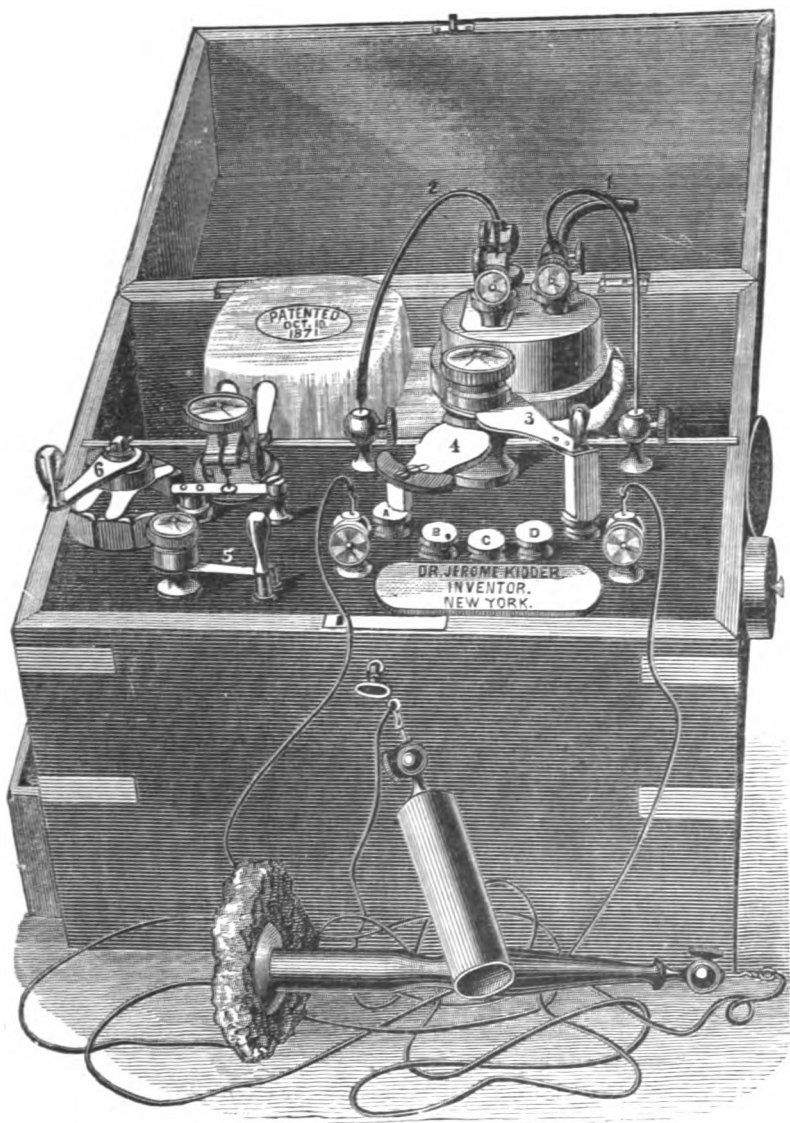

FIG. 44.

Faradic Machine, with a tip arrangement (Kidder).

the rapid interruption in producing muscular contraction, for a strong galvanic current interrupted will cause muscles to contract that will not respond to the faradic current whether slowly or rapidly interrupted.

In this battery the cell is placed on pivots so that it can be easily turned over 90°. When upright, the metals are immersed; when turned over, the metals are out of the solution. The stopper is of rubber, and it is provided with a rubber funnel for the escape of the gases. This arrangement is a very great advance on the old one, where each time the machine was used, there would be pouring of the acid and necessary spilling into and from a bottle.

For the past year we have used only this tip element, having discarded entirely the old arrangement. It is not ornamental, but is very convenient.

Smee's cell is a very convenient cell to take care of, and when not kept too long immersed, or used with too strong solution, is very enduring.

The current of Kidder's faradic machine is a very pleasant one, and is especially adapted for nervous and sensitive patients, on whom general faradization is employed. The agreeable character of the currents that come from it is to be explained in part by the fact that it is a continuous-coil machine—all the different coils, from three to six in number, being connected—and in part by the construction of the rheotome; but mainly, we think, by the former, since, as has been stated, all single-coil machines, other conditions being the same, give a pleasanter current than separate-coil machines.

The character of the current is, as we have seen, modified by the length and fineness of the wire in the different parts of the coil. The inner coil (A B) is of thick wire and is short, and gives a very mild current; the second coil (B C) is of thinner wire, and is longer, and gives a stronger current; the third coil (C D) is still finer and longer, and gives a still stronger current. The majority of these instruments have but three coils; but in some of the larger instruments one or more coils (E and F) have been added. All these coils are metallicly connected, so that they really constitute one long coil, varying in different parts in the fineness of the wire.

All the currents that come from this battery (A B, B C, C D, D E, A D, A E, etc.) may, therefore, be regarded as modifications of the primary current (see *Electro-Physics*, p. 62). Inasmuch as electricity is modified by the nature of the substances through which it circulates, it follows that coils of different length and fineness will give different

varieties of currents ; this is found to be the case with the battery under consideration. It is found that the currents vary not only in strength, but in the nature of their effects, with the portion of the coil from which they come ; that they cause different sensations when applied to the body. The differential therapeutic action of these currents is too complex to be readily or satisfactorily demonstrated.

#### RULES FOR THE USE AND CARE OF KIDDER'S FARADIC APPARATUS.

The directions that we give under this head will apply in general to all, or nearly all, faradic machines, and, therefore, need not be repeated in the descriptions of other machines that are illustrated in this volume.

*To prepare the Apparatus for Use.*—Fill the glass jar with a solution of water and sulphuric acid—one part sulphuric acid to eight or twelve parts water. It is not necessary to be rigidly mathematical in regard to the quantity of the sulphuric acid. The average proportion is one-tenth, but it may range between one-sixth and one-sixteenth. The jar should be about two-thirds filled with the solution.

It is also necessary to put about a teaspoonful of quicksilver in the cup. This touches the lower end of the zincs and keeps them constantly amalgamated. (See Electro-Physics, p. 37.)

The quicksilver should not be allowed to touch the central plate of platinum, as it may injure it. In some of the modifications of this apparatus it is necessary to close the prongs between one of the brass posts that is labelled and the one in the middle that has no label.

The apparatus is now ready for action. If the spring does not at once vibrate, give it a slight stroke with the finger. If it still refuses to vibrate, it may be necessary to readjust the screw. If the spring vibrates, but irregularly or too slowly, the evil may usually be remedied by readjusting the screw.

Now connect the strings attached to the electrodes with the lettered posts. A is always the positive pole, and B, C, and D are always negative relatively to A.

*To distinguish the Poles.*—It is always possible to distinguish the negative pole by holding the electrodes for a moment in the two hands ; the one in which the current *is strongest felt is the negative pole.*

If the apparatus refuses to go, or if it stops at any time while in use, the cause may be looked for—

1. *In the screw of the rheotome or current-breaker.* This may not be properly adjusted. The point may be too far from the spring, or too

closely pressed upon it. This want of proper adjustment of the screw is the most frequent cause of a stopping of the machine, and of the refusal of the spring to vibrate. The spring may sometimes be corroded at the point where the screw touches it.

2. *In the connection of the wires.* The wires that unite the zincs and platinum may not be properly screwed at their point of connection, or may be corroded.

3. *In the battery itself.* The battery—that is, the zinc and platinum, with the solution in the glass jar—may get out of order in four ways. *First*, the solution may lose its strength. This difficulty may be remedied either by pouring in some sulphuric acid or by making an entirely new solution, or by simply adding more water. *Secondly*, the zincs may become so corroded and incrustated as to become incapable of generating a current. When we have reason to suspect that such is the case we should clean them with an old tooth-brush or cloth, or amalgamate them. When the zincs have lost their amalgam, local action may take place; this will be indicated by rapid evolution of hydrogen. *Thirdly*, a portion of the mercury may have fallen onto the platinum, and covered it. When this happens, little or no current can be obtained. *Fourthly*, the platinum and the zincs will, in time, by hard and long usage, wear out, and will need to be replenished.

4. *In the helix.* It is very rarely indeed that the helix of this apparatus ever becomes so injured as to become incapable of service. If, after we have properly adjusted the screw and spring, made sure of the connections of the wires, replenished the solution and cleaned the zincs, the apparatus persistently refuses to go, we have reason to suspect that something may be wrong with the wires that compose the helix. If such be the case the evil can be remedied only by the inventor himself, or, at least, by some one practically familiar with the construction of helices. But we should try very patiently and perseveringly before we accept the conclusion that the helix is thus out of order, for it is an accident of extremely rare occurrence.

When no current is felt at the electrodes, although the apparatus acts properly, we know that *the connection is broken somewhere in the insulated conducting wires.* Sometimes the union of the wires with the electrodes is imperfect, and occasionally the wire in some part is broken. Finally, the electrodes themselves may become very much corroded, and may need cleaning before a good current can be obtained.

*To take care of the apparatus.*—When not in use, the element can be taken out of the solution. When the tip battery is used, all that is necessary is to merely turn over the jar. If the element remains too long



a time in the jar an incrustation of salt will sometimes accumulate on the top of the zincs which will need to be brushed or washed off. This salt is the sulphate of zinc, resulting from the action of the sulphuric acid on the zinc.

We may know that action is taking place in the battery when bubbles of hydrogen are rising up by the sides of the zinc.

*Methods of modifying the Current.*—The strength of the current of this machine may be modified in several ways, as follows :

1. It may be modified by withdrawing or pushing in the metallic tube that covers the helix.

When this tube covers the helix an indefinite number of branch currents are induced in it that interfere with the main current and weaken it. In proportion as this is withdrawn, the induction of branch currents, and the consequent interference with the main current, grows less.

This method of modifying the strength of the current must be used continually both in general and localized faradization.

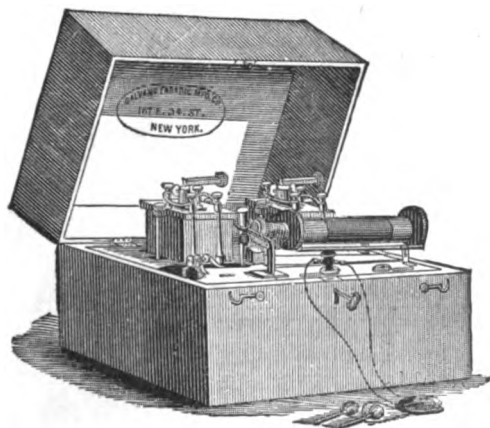

FIG. 45.

**Faradic Machine, separate coil, double cell, in box** (Galvano-Faradic Manufacturing Co.). F F are the two elements of zinc-carbon ; A A the rods by which the zinc is raised from, and lowered into, the solution ; D the hammer, and H the helix partly drawn out. These machines are run by one or two zinc-carbon cells (Walker's Battery, see p. 35, in *Electro-Physics*).

2. The current may be modified by increasing the quantity of the solution, or of the sulphuric acid in it. This measure can be resorted

to when the current fails to accomplish our purpose, even when the metallic tube is entirely or nearly withdrawn.

3. When the current passes through the body of the operator, the

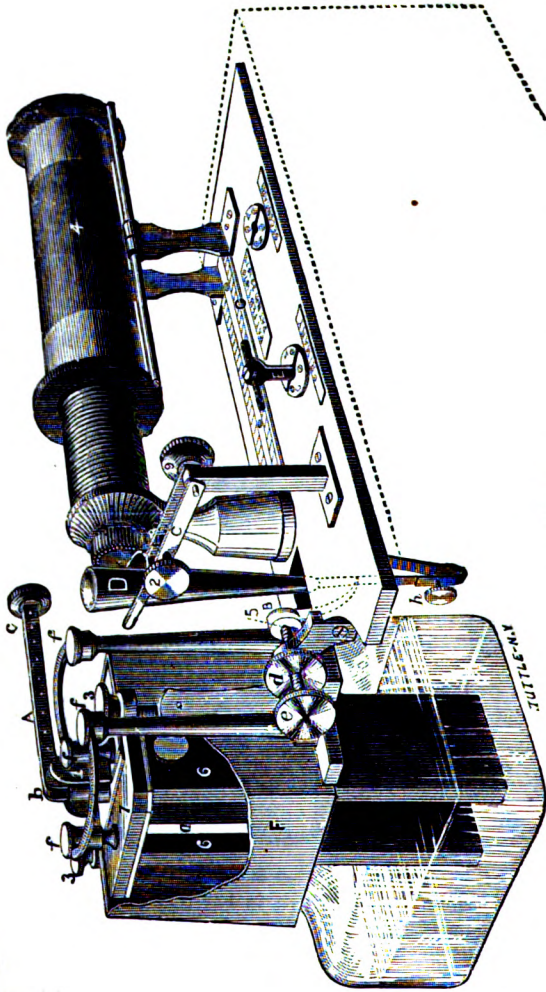

FIG. 46.  
Faradic Machine, without the box (Galvano-Faradic Manufacturing Co.).

current may be modified by increasing or diminishing the pressure of the hand on the sponge connected with the positive pole. (See General Faradization.)

The *direction* of the current can be changed, at any time, by reversing the position of the electrodes, or by reversing the conducting wires in the posts, or by the current-reverser, when one is attached to the machine.

The faradic machine represented in Fig. 46, besides being of the separate-coil variety, giving both the primary and the secondary current, has also a very convenient contrivance for producing slow or rapid interruptions.

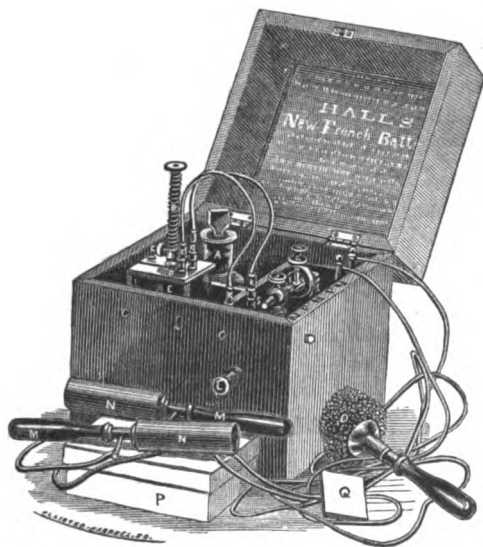

FIG. 47.

Faradic Machine (continuous coil) (Thomas Hall).

The machine of Hall is a neat, compact arrangement, and gives a very pleasant current. Chromated lead is used for the electro-negative element. One of the metals is raised out of the solution by a very convenient spring, instead of the jointed-rod.

*Magneto-Electric Machines.*—The *magneto-electric* (or so-called *rotary*) machines (see *Electro-Physics*, p. 61) are not much used at the present day, and are not ordinarily to be recommended. They have been employed largely and indiscriminately, especially in this country, and have done the cause of electro-therapeutics much evil. Although the current afforded by them is well adapted to produce muscular contractions, and is frequently of service in the treatment of paralysis, rheumatism, and kindred disorders, yet, for all the wide range of diseases in which

faradic electricity is indicated, it is neither sufficiently reliable nor sufficiently effective. In most of the conditions of irritability, in which general faradization is most effective, this form of electricity, as generated by most of the machines, is contra-indicated, on account of the rough and disagreeable quality of the current.

Another very prominent objection to most of the rotary machines in this country is, that they require the aid of an assistant to turn the crank. This objection may be met by clock-work attachment. An arrangement of this kind is employed by Dr. Morell McKenzie, of London, in the treatment of paralysis of the larynx; but even for this special purpose it would seem to have no advantages, but positive disadvantages, as compared with a compact, convenient, and reliable electro-magnetic apparatus as described in the preceding pages.

M. Gramme \* has made a magneto-electric machine which furnishes a *continuous* instead of an interrupted current, which in its effects resembles the ordinary galvanic current. The machine consists of three rings of soft iron, around which is an endless coil of copper wire. Each of these rings rotates between the poles of a powerful magnet, and the arrangement is such that the opposite currents in the halves of each ring form a single continuous current.

The machine is turned by hand, and in its large form generates a large quantity of electricity. It can produce all the effects of the ordinary galvanic current. It makes platinum wire red hot, fuses metals, and is used in electro-plating.

If this machine can be reduced in size, and modified in shape, it may become of value in electro-medicine and electro-surgery.

*Galvanic Apparatus.*—The merit of placing in the market, in an accessible form, convenient and reliable *galvanic* batteries, was in this country pioneered by the Galvano-Faradic Manufacturing Company. Before the organization of this establishment the faradic machines of Kidder and others had been long in use, but suitable galvanic machines could not be obtained.

*Hydrostat.*—The hydrostat is an admirable contrivance for keeping the fluid from spilling when the battery is carried in a buggy or on a long journey. It consists of a rubber covering accurately fitted on the top of the cells, and we have found it a most trustworthy arrangement. A battery of sixteen cells, made by this company, we once took with us *charged* three hundred miles into the country on a consultation, and not a drop was spilled.

\* Althaus on Medical Electricity, third edition, 1874, p. 88.

We may remark here that on the street or steam cars, a battery that is charged will not usually spill. It is in omnibuses and in buggies that the hydrostat is needed.

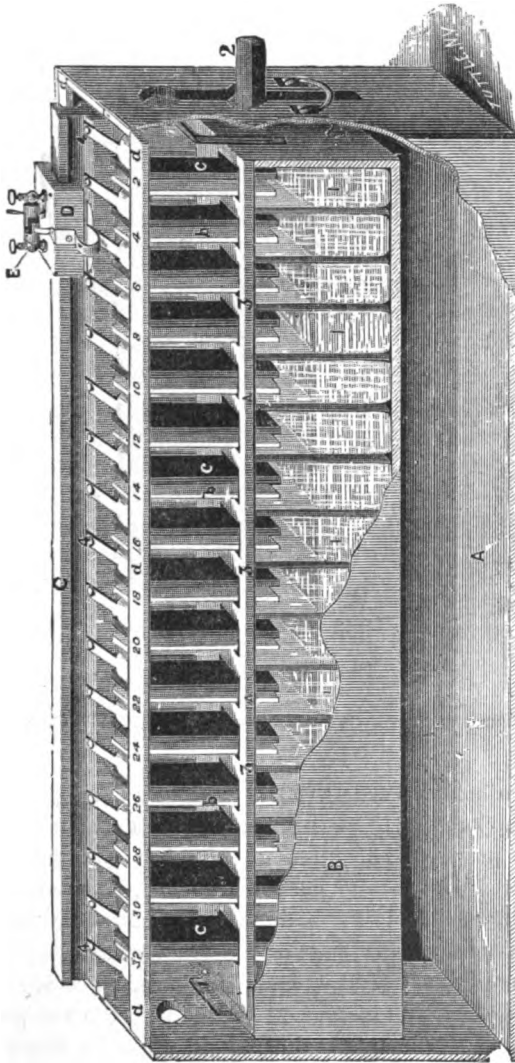

FIG. 48.  
Thirty-two cell zinc-carbon office battery, with slide, current interrupter and reverser, and hydrostat  
(Galvano-Faradic Manufacturing Company).

The zinc-carbon batteries are also constructed on the same general principle of sixteen and eight cells. The sixteen-cell combination is

portable, and about as heavy, when charged, as a medium-sized valise, well packed.

The eight-cell combination is no heavier than a common faradic machine, and when well charged gives a current of sufficient strength for many applications to the eye and head.

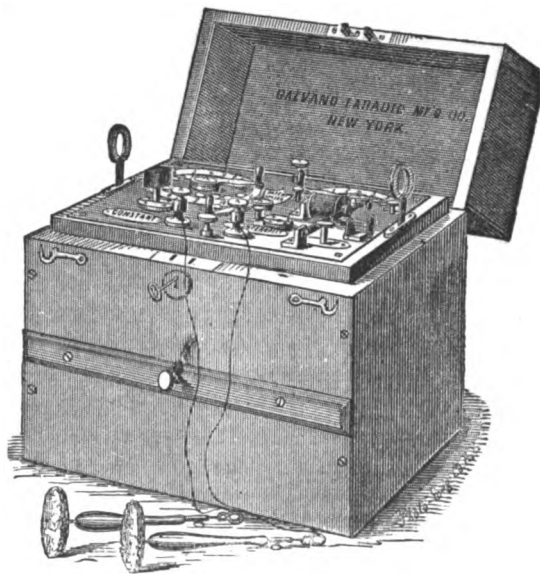

FIG. 49.

Twenty four zinc-carbon battery (Galvano-Faradic Mfg. Co.).

The above is called the Bartlett galvanic battery (Fig. 49). It is a very convenient apparatus. It has connected with it a hydrostat, which quite successfully prevents the spilling of the solution during transportation. The accessories, such as current selectors, commutator, rheotome, etc., are all attached to the battery. The bottom of the box is a movable tray, in which the glass or hard-rubber cells are placed. This movable tray is controlled by two hinged rods, which are fastened to it, and these by two lifting-rings at the end of the rubber table. These rings, being screwed tightly down, hold the cells firmly against the hydrostat, or, being loosened, allow the hydrostat to be removed from the front of the centre of the box. They also serve as handles to lift the tray of cells.

*Practical Directions for the Use of Zinc-Carbon Galvanic Batteries.*

The following directions will substantially apply to all or nearly all forms of the zinc-carbon battery, by whomsoever manufactured.

*How the Battery is Constructed and Used.*—These batteries are composed of plates of zinc and carbon in a solution of bichromate of potass, sulphuric acid, and water. The solution is contained in glass jars that are raised up to the plates of zinc and carbon by the keys at the ends of the box, or by a crank. When the jars are raised by the keys

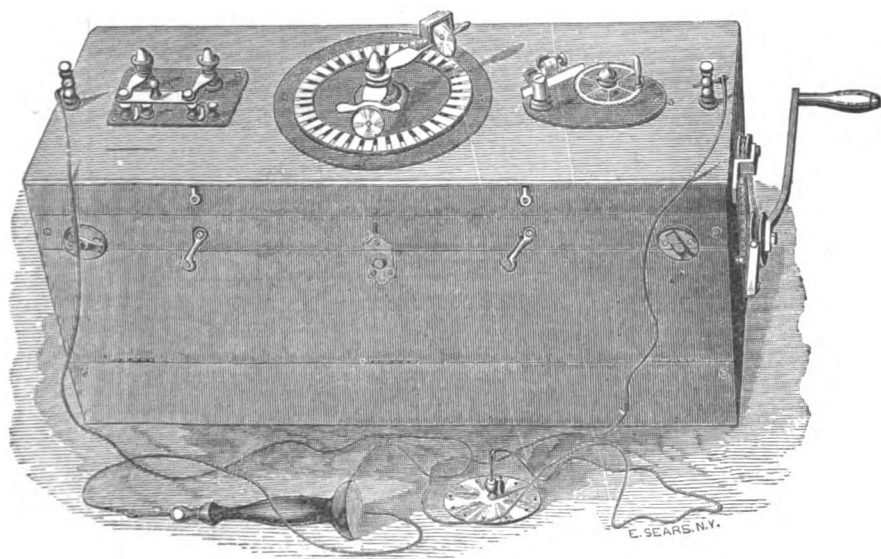

FIG. 50.

Thirty-six large zinc-carbon cell galvanic battery, with circular switch, reverser, and interrupter, for office or hospital use (Kidder).

to the top of the box, *turn the keys at right angles*, or turn the crank, and the jars will stay in position, and the battery is ready for use, if the jars are properly filled with the solution.

When the battery is not in use the jars should be let down from the plates by means of the keys. If allowed to remain immersed day after day the battery will rapidly lose its strength. (See *Electro-Physics*, p. 36.)

*How to Charge the Battery.*—The solution is made in about the following proportions: sulphuric acid, 1 oz.; bichromate potass,  $1\frac{1}{2}$  oz.;



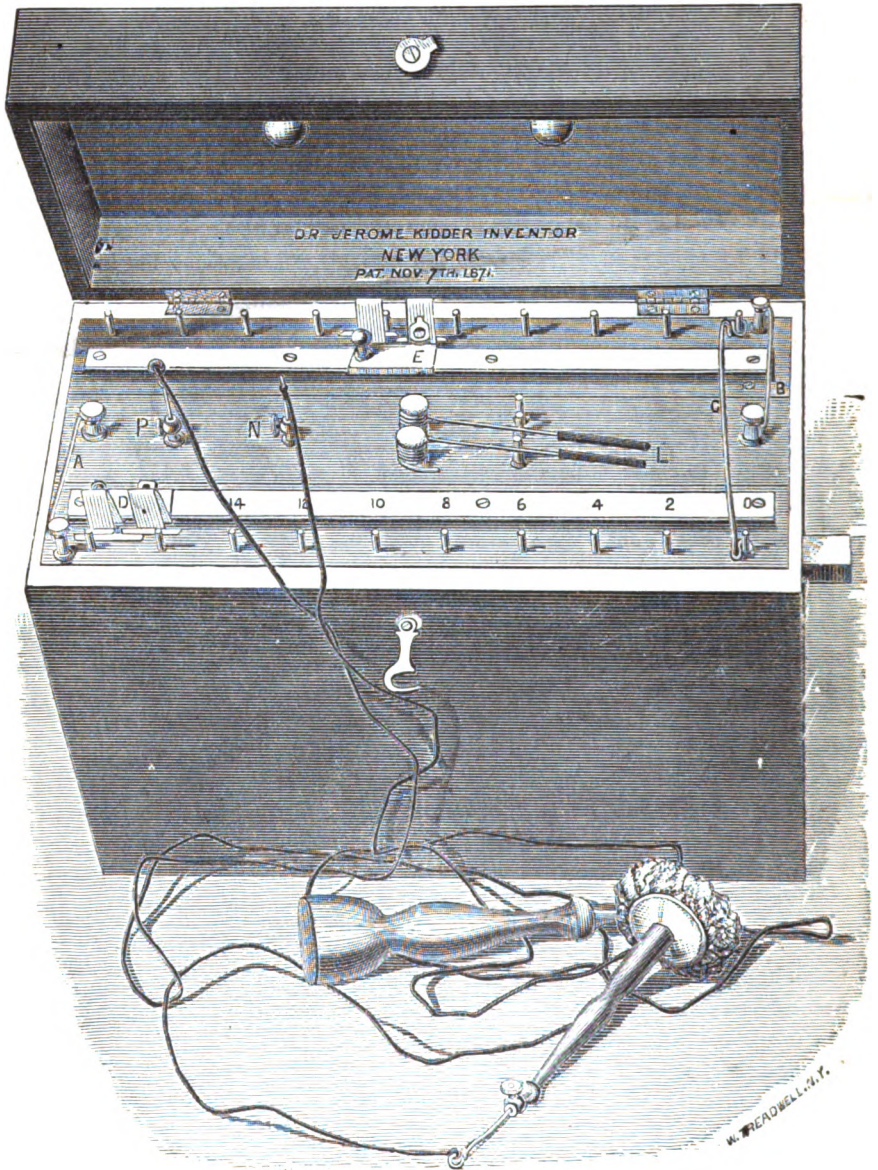

FIG. 51.  
Eighteen-cell zinc-carbon battery (Kidder).



water, 10 oz. The best way to make the solution is to dissolve the bichromate of potash in cold water and then add the sulphuric acid. The mingling of the water and sulphuric acid causes great heat. *Do not use the solution until it is cool.* We had not been able to get any satisfactory explanation of the fact that solutions when *hot* injure the battery, until Prof. Brackett, of Princeton, informed us that from experiments he made several years ago he proved that when the bichromate of potash solution is used hot a layer of ozone is formed on the carbon; this at once weakens the current.

Lift out the plates by the middle piece to which they are attached, lift up the jars by the keys and fill each jar with two, or three, or three and a half ounces of the solution. They should be filled pretty uniformly, and care should be taken that no more should be put in than the jars will hold after the plates are immersed.

*How to clean the Battery and Amalgamate the Zincs.*—Every few weeks or months, according to the extent to which the battery is used, it will be necessary to wash the plates and scrape off the exudation and renew the solution, or, at least, to add more acid or water, and amalgamate the zinc. The *chrome alum* that collects in the bottom of the jars (see Electro-Physics, p. 36) and becomes very hard can be softened by allowing warm water to stand in the jars for a time, and then loosening the deposit with any sharp instrument. A good way to amalgamate the zincs is, take a strip of zinc, dip it in a solution of sulphuric acid and water, then dip it in mercury; the mercury will adhere to and run over it; then rub up over the surface of the zincs of the battery until all are well covered with mercury. During the process of amalgamation the zincs should be kept well moistened with a solution of sulphuric acid and water. (See Electro-Physics, p. 36.)

*How to tell the Strength of the Current.*—Those who have no galvanometer can tell whether the current is running and how strong it is by putting one pole in the hollow of the hand and the other between the thumb and forefinger. The poles should be wet with salt water or simple warm water. Those who have been accustomed only to the noisy and violent faradic (induced) current, will be disappointed to find that this galvanic current causes only a *slight burning sensation*, with no shocks except when interrupted. A current that is scarcely felt when applied in the hand, may be too strong to apply to the head, or face, or neck. *The greatest mistakes are made by using the galvanic current too strong.*

*How to distinguish the Poles.*—The current is felt strongest at the **NEGATIVE POLE**. When both poles are dipped in a solution of iodide

of potassium, the brown color of the iodine appears at the POSITIVE POLE.

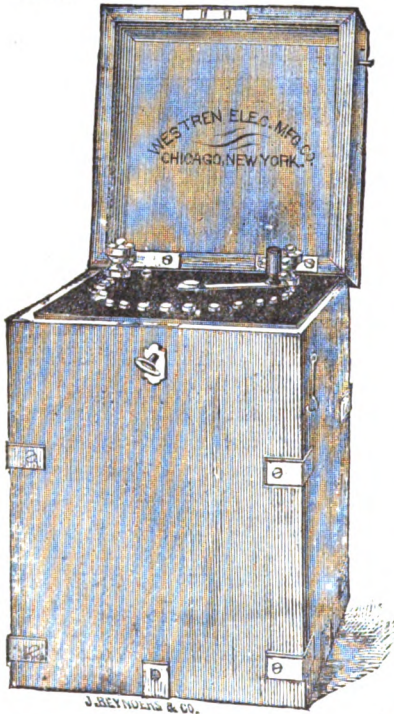

Sixteen cell battery complete.

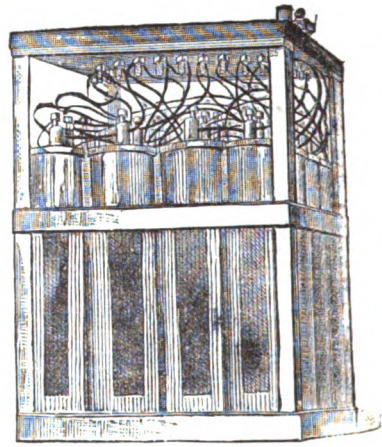

FIG. 52.

Cells out of case.

Chloride of silver battery.

The cell in the above battery is very small, being one and one-quarter inches square by five and one-half deep. It contains a strip of zinc and a strip of silver, the latter being covered with about 8 dwt. of fused chloride of silver. The solution is water and sal ammoniac, in the proportion of a pint of the former to  $8\frac{1}{2}$  dwt. of the latter.

*The Cabinet Battery.\**—A little more than a year ago it was suggested to the Galvano-Faradic Manufacturing Company the possibility of arranging a combination of sixty or more Siemens-Halske elements of moderate size, in such a way that all the cells and all the connections and appliances should be contained in a small movable desk or bureau. The suggestion was made in the belief that all the supposed or real advantages of the combinations of large cells that are usually placed in cellars or basements, and connected by wires with

\* Some changes have been made in the form of this battery since the last edition, but the general principles of its construction remain the same.

the operating room, could be secured at far less trouble by a simple, convenient, and accessible arrangement, in which many of the difficulties connected with removal, cleaning and overhauling should be reduced to a minimum.

In the roughest possible manner a general plan of a bureau with drawers and cover was drawn and it was further suggested that it would be well to have a current-selector, current-reverser, rheostat, and galvanometer interposed in the circuit, and that the appliances should all be in a plane surface at the top; and that the drawers containing the cells should be so made that they could be easily taken out whenever necessary to inspect and replenish the battery. We thought little more of the matter until November last, when the Company called our attention to the fact that they had completed a battery which they called the Cabinet battery, and which is represented in the accompanying cut.

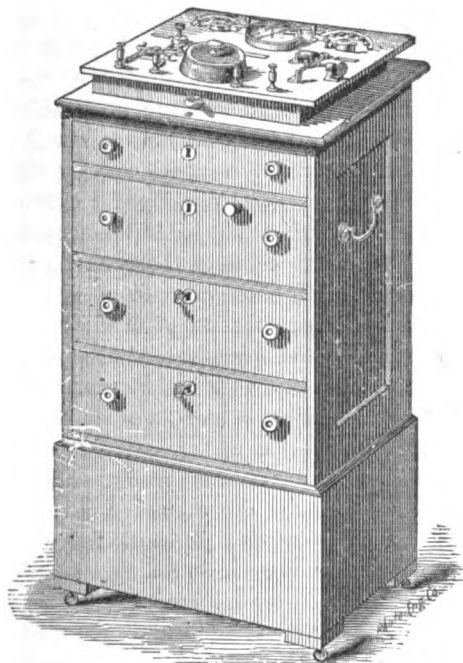

FIG. 53.

The Cabinet battery is so simple that a very brief description of it will be sufficient. The Siemens-Halske cell is merely a modification of

Daniell's cell. It consists of a small cylinder of glass, attached at the bottom to a cylinder of porcelain. In this cylinder is placed a coil or ribbon of copper, and a little water. Outside of this cylinder is a cylinder of zinc, and the space between it and the outer glass jar is sawdust on the top, and at the bottom powdered papier-maché packed closely, and wet with water slightly acidulated with sulphuric acid. The object of the sawdust and papier-maché is to hold the fluid and avoid spilling and to make the action of the battery gentle and uniform. A cork is placed in the cylinder so as to prevent mingling of the fluids of the outer and the inner cells.

These cells, like all modifications of Daniell's cell, are very constant; that is, they give a *steady* and *uniform* current, and can be used for a long time without recharging. It is necessary, now and then, to drop a little water into the inner cylinder to make up for the loss by evaporation, and to put in a few pieces of sulphate of copper; this, however, can be very easily done by pulling out the drawers and removing the corks. Each cell is about the size of an ordinary tumbler. There are three drawers, each containing twenty cells.

The metallic connections of the cells are made at the back part of the drawer, and are completed when the drawer is well pushed in. On the top of the bureau are the current-selector, by which one cell or sixty cells can be brought into the circuit; the current-reverser; the short-coil galvanometer for indicating the presence and direction of the current merely, and the hydro- or water rheostat, for gradually increasing or diminishing the strength of the current.

The water rheostat is the perfection of neatness and convenience, and is differently arranged from any that we have seen. The water is contained in a small case or cup, with a glass top. By turning a small brass disk, connected with a brass lever, a small or large area of the water can be brought into the circuit. Beside all the appliances for the galvanic current, this Cabinet battery also provides the *faradic* current. Two Leclanché cells in the upper drawer are connected with a continuous coil and interrupter, on the right hand of the top of the bureau. The faradic current can be increased or diminished by pulling out or pushing in a metallic rod in front of the top piece.

The advantages of this Cabinet combination are these:—

1. *It is very easily moved and managed.* The whole Cabinet, containing sixty cells, the electrodes, connections, etc., for both currents, and the cover to place over the top, is but three feet high and seventeen inches broad. It is placed on castors, and can be easily moved from one ward of a hospital to another ward, or about the room, by one

person, as easily as an ordinary centre-table. The combinations of Daniell's cells are generally placed in the cellar, and the apparatus throughout is permanent, and when the physician wishes to move his office the labor of resetting the battery is very great. This combination, without taking out the drawers, can be transported bodily from one house to another as easily as any bureau the drawers of which are filled with heavy goods.

Although the battery will probably go for years without thorough overhauling, yet occasional inspection and refilling will be required, and can be very easily performed.

2. *It gives a constant, uniform, and steady current; and is, therefore, better adapted for the treatment of irritable and sensitive conditions than the small cells of the ordinary portable batteries.*

This advantage it shares with all modifications of Daniell's battery. The explanation of the constancy and steadiness of the current from these combinations of Daniell's cells is found in the fact that on account of the feebleness of the solution, and the interposition of the porous cell, the chemical action is slow and uniform, with no interruptions or even variations. In the single zinc-carbon cells the solution is very strong, and the chemical action very vigorous; the plates are rapidly polarized; the density of the solution, and with it the internal resistance of the battery, is continually changing as a result of the vigorous chemical action, and consequently the strength of the current not only diminishes after a protracted use of the battery, but *it varies from moment to moment.*

The potential quantity of electricity may be the same in a combination of single zinc-carbon cells, as in a combination of sawdust Daniell's cells, and may even be far greater; but there is great difference in the rapidity with which they evolve it. For short work, such as is required in powerful electrolytic operations, the single zinc-carbon cell is far preferable to the Daniell, for the reason that the quantity of electricity that it generates in a short time, say half an hour, is very much greater than a similar number of Daniell's cells would generate in the same time. This Cabinet battery is therefore not a good battery for electrolysis, and we never attempt to use it in any important electrolytic operations. In experimenting with it we find that it causes but a very feeble decomposition of iodide of potassium, or chloride of sodium. It could not indeed be otherwise; in electrolysis, as everywhere, force answers to force; the amount of chemical action *outside* of the cell—electrolysis—must be proportioned to the amount of chemical action *inside* of the cell. In the Daniell's cell the chemical action is very slow

and feeble; hence, the electrolysis it causes is slow and feeble, but it is constant and steady; it does not give out so much electricity in an hour as the single zinc-carbon cell, but it continues to give it out long after the zinc-carbon cell is exhausted.

Two men have each a thousand dollars; one spends recklessly, rapidly, and extravagantly, and in a few days is penniless: the other spends regularly and slowly, and uniformly, one dollar each day, and makes his thousand dollars last a thousand days. The single zinc-carbon cell makes an extravagant battery; but in electrolysis extravagance is needed, and besides the solution can be removed from the plates, so that no action can take place when the battery is not needed. The Daniell's cell makes an economical battery, since it spends slowly and regularly, even though it is kept constantly immersed. Hence its advantage in the treatment of the neuralgic, the hysterical, and the nervously exhausted, who in some cases, at least, require to be treated with feeble, mild, steady, and *painless* currents. The current from these Daniell's cells is less painful than the current from small and active cells, for the reason mainly that it is more uniform.

The notion entertained by some that these large double-cell batteries send a larger *quantity* of electricity through the body than small cells, is at war with Ohm's law, and has no foundation in experience. The resistance of the body is so great in comparison with the internal resistance of the batteries, that it makes but little difference in regard to the quantity of electricity that flows through the body whether the cells are large or small. As a matter of fact, the small single zinc-carbon cells, or even the ordinary Smee's cell, give larger quantity of electricity for a short time than the large Daniell's cell. (See *Electro-Physics*, pp. 66-84.)

The arrangement in Fig. 54, is very light, compact, and portable. The cells are quite small, and of course need refilling more frequently than larger cells. The cord spools (S S) are convenient contrivances for winding up the cords when not in use.

These batteries are made also of ten, twenty-four, and forty cells.

The combination in Fig. 55, embraces both the faradic and the galvanic currents, sixty zinc-copper cells—and a rheostat. The same coil that furnishes the faradic current can also be enclosed in the circuit of the galvanic current so as to form a rheostat. Connected with the apparatus, on a board in front of it, is a current-reverser, a current-interrupter, and a galvanoscope.

The faradic current is supplied by a continuous coil with many windings, and gives a very pleasant current.

These batteries (Fig. 56, p. 315) are of twelve, or twenty-four, or thirty-six cells. The general construction of the Leclanché cell has already been described in *Electro-Physics*.

Curt W. Meyer also manufactures a combination of Leclanché's cells that is conveniently portable, and is said to be quite enduring. These small Leclanché cells are not as enduring as those of a larger size, and when frequently used must be frequently clear, like the zinc-carbon batteries.

*Raines' Battery*.—Prof. George W. Raines, of Augusta, Georgia, has described\* a portable galvanic battery, composed of strips of zinc and

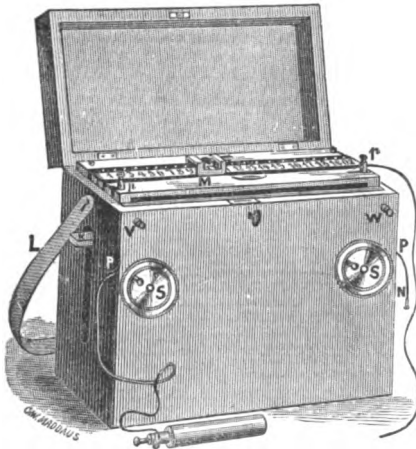

FIG. 54.

Portable galvanic battery, twenty zinc-carbon cells (Drescher).

platinum, united by copper strips in the shape of the letter V inverted. These zinc and platinum strips thus united are passed through holes made in a rubber plate, beneath which is a square trough of rubber, divided into forty-nine compartments or cells. These cells contain the acid solution, which can be raised to the metallic strips so as to immerse them. The whole battery is about the weight of a No. 4 faradic machine of the Galvano-Faradic Co.'s manufacture.

*Galvanometers or Galvanoscopes*.—The general principles on which galvanometers are constructed have been already described (*Electro-Physics*, p. 40).

A galvanometer which, by Dr. Rockwell's suggestion, was made by Messrs. Chester & Co., is represented in Fig. 58. It is of the long-coil variety, and is provided with a "shunt," which has a resistance equivalent to 150 miles of telegraph wire. This galvanometer measures with

\* *Scientific American*, September 28, 1872.



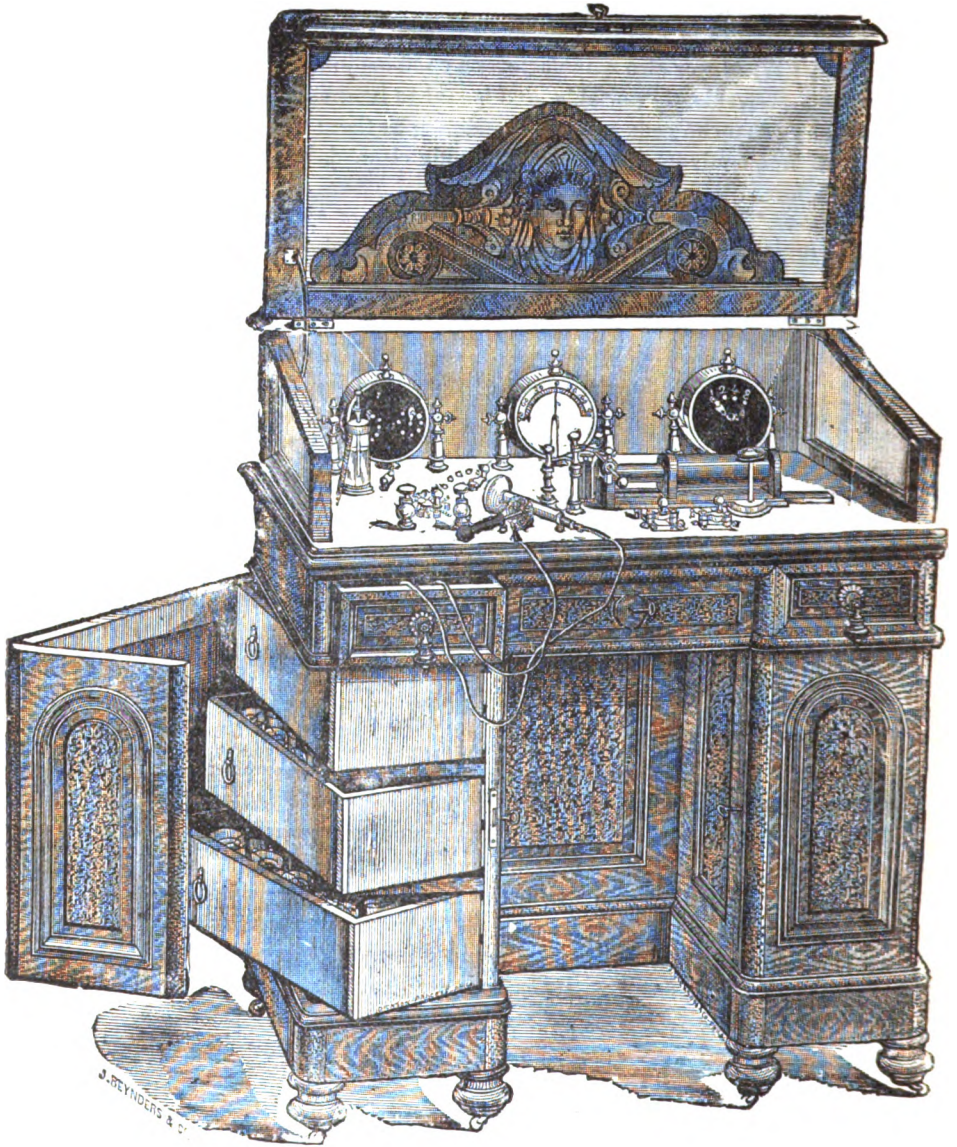

FIG. 55.

Galvano-faradic machine, with rheostatic coil, etc. (Reynders & Co.).



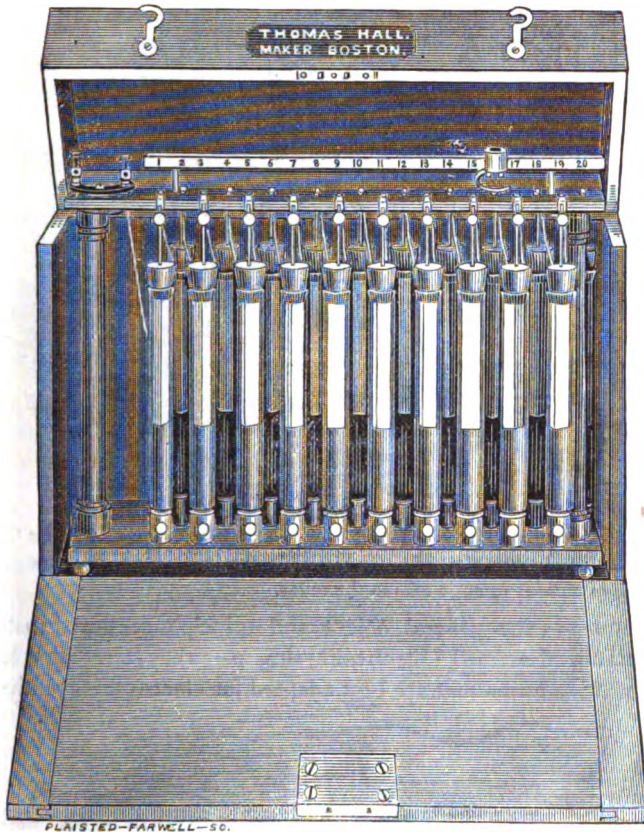

FIG. 56.

Portable Beetz-Lechanché battery, twenty cells (Thomas Hall).

considerable accuracy the strength of the galvanic current, since the deflection of the needle is in tolerably exact proportion to the number of cells introduced into the circuit. It is very useful, therefore, in comparing different batteries, or the same battery at different times, in order to determine how much power it has lost. When a thirty-two-cell zinc-carbon battery is in perfect order it will deflect the needle of this galvanometer from  $40^\circ$  upwards; fifteen cells will cause a deflection of about  $20^\circ$  or  $25^\circ$ . The deflection of the latter part, when a large number of cells are introduced, is not exactly proportional as in the first part, but sufficiently so for all practical uses.

The ordinary "short-coil" galvanometers (galvanoscopes) are so delicate that one or two cells send the needle round to  $90^\circ$ , and are therefore useful only to determine the presence and direction of the current.

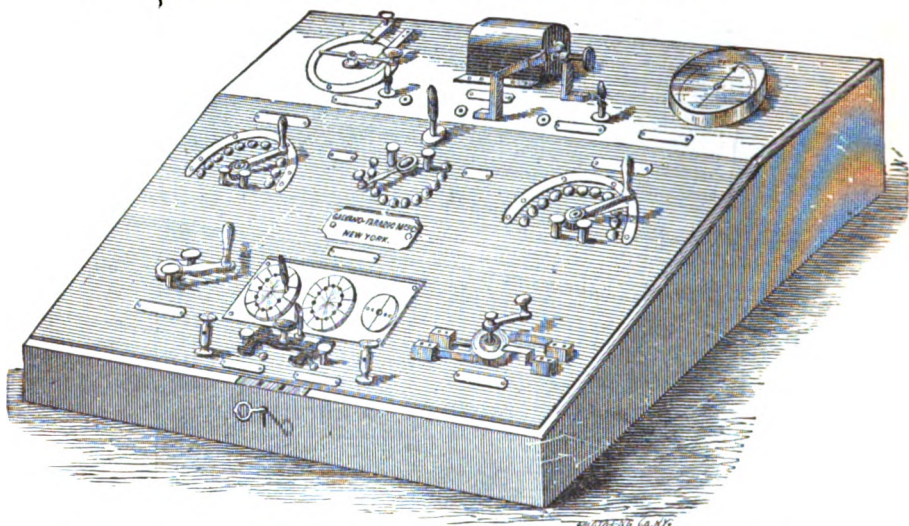

FIG. 57.

Brenner's Apparatus, including Stopper Rheostat, Galvanoscope, Faradic Coil, etc. (Galvano-Faradic Manufacturing Co.). This apparatus may be connected with any desired number of large cells in the cellar.

*Rheostates.*—The general object and principle of the rheostat has been already described (Electro-Physics, p. 42). It remains here to speak of those forms that are best adapted for electro-therapeutics

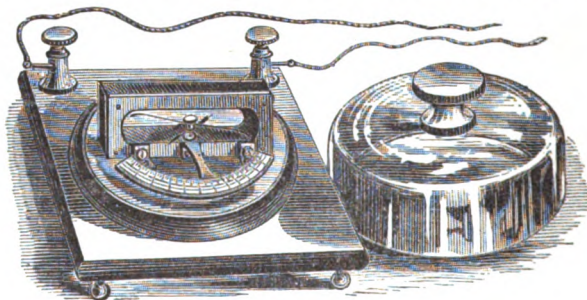

FIG. 58.

Galvanometer used by the Authors. (Chester & Co.)

A form of rheostat, very well known to electro-physiologists and electro-therapeutists, is that of Siemens, and introduced into electro-therapeutics by Brenner in his researches on the ear. The unit of Siemens is a column of mercury, one metre long, with a transverse section of one square millimetre at 32° F. The rheostat may contain 1,110 or 2,100 units. The metallic blocks or pieces on the top are attached to insulated coils of wire, which in their length correspond to

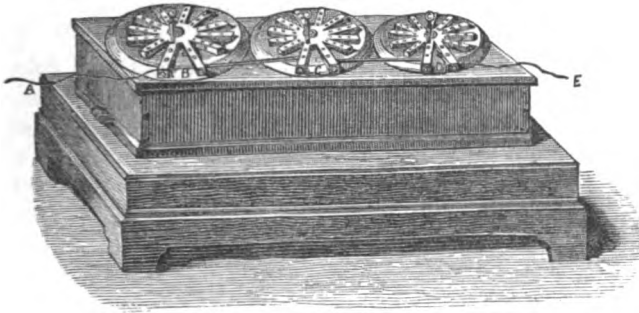

FIG. 59.

**Siemens' Stopper-Rheostat.**—On the circle B, the metallic disks are numbered by units from 0 to 10; on the circle C, by tens, from 0 to 100; on the circle D, by hundreds, from 0 to 1,000. To use the rheostat, connect the wire A with one of the poles of the battery, and the wire E with one of the electrodes: in this way the resistances of the rheostat are included in the circuit, constituting what is called a “secondary closure.”

the numbers 1, 2, 3, 4, 5, 6, 7, etc., 10, 20, 30, 40, 50, 60, etc., 100, 200, 300, 400, etc., marked over them. At the central end of each division of the star-shaped top-piece there is a hole for receiving the stopper. When all the stoppers are inserted in the division marked 0, there is no resistance in the rheostat, and the current goes directly through it, and not at all through the body of the patient, for the reason that metal conducts electricity very much better than the body, and when it has a choice it will take the path through the best conductor.

When now, the stoppers are inserted so that some of the coils of wire connected with the divisions of the top-piece, say those marked 5, 50, 500, are brought into the circuit, the current will have to overcome not only the resistance of the metallic connections, but also the resistance of 550 Siemens' units, represented by corresponding lengths of copper wire, and by preference much more of the current will pass through the body. If all the resistances, 1,110 or 2,100 units, are interposed, most of the current passes through the body. If all the stoppers are removed, a part of the current goes through the rheostat.

**Rheostat of Mayer & Wolff.**—Mayer & Wolff, of Vienna, have constructed a simple form of rheostat—a wooden box containing coils of wire corresponding to 1,605 Siemens' units.

**Hydro-rheostat (water rheostat, or liquid rheostat).**—For all the practical purposes of electro-therapeutics, even for the most delicate applications to the most delicate organs, as the ear, eye, etc., the common water rheostat—or, as it is sometimes called, hydro-rheostat, or liquid

rheostat—is sufficiently precise, and in convenience is incomparably superior to the stopper rheostates.

The water rheostat, represented in the cut, is simply a column of water, interposed in the circuit, and so arranged that the distances between the extremities of the metals that close the circuit through the water can be increased or diminished at pleasure.

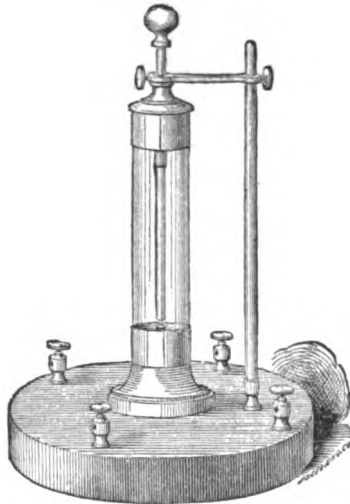

FIG 60.

Hydro-Rheostat (Galvano-Faradic Manufacturing Co.).

The precision that physiologists and physicians obtain by the use of the stopper rheostat is more apparent than real. A study of Ohm's law will show that the quantity of electricity that flows through the body in any electrical application, depends not alone on the nature of the conducting wire, and the number of cells employed, but also on the nature of the electrodes, the quality and degree of moisture in them, the amount of pressure used, their distance from each other, and the part of the body that is treated. Those who are particular to state the number of cells employed, and the number of units interposed, are therefore much less precise than they suppose; for, besides all the qualifications just given, the strength of even the most constant cells varies more or less from time to time (see chapter on Ohm's Law, pp. 66-84.) Reports, therefore, that contain in full detail the number of elements employed, and the number of units interposed in the circuits, are apparently but not really precise; the careful physiological researches on definite and very limited portions of tissue, the statement of the kind of cell employed, and the number of them and the number of resistances of

the rheostat interposed, may convey an approximate idea of the strength of current, and thus may be of service to other investigators, but in the very nature of things they cannot be accurate. In the ordinary applications of electro-therapeutics, unless it be limited electrolysis, we oftentimes state the number and kind of cells employed, but always with the implied proviso that we are suggesting approximate and not mathematical truth.

So far as producing delicate shades and grades of sensation is concerned, the water rheostat, when properly constructed and adjusted, is fully as trustworthy as the stopper rheostat, and far more convenient for the operator. A rheostat of some form, though not indispensable in electrical applications, is yet a great convenience, and, especially in central galvanization and in local galvanization of the nerve-centres, a very great convenience. In ordinary peripheral applications, unless it be to very sensitive parts, the rheostat is not required.

*Electrodes.*—Of the many varieties of electrodes, we shall describe those only that are practically useful.



FIG. 61.

Universal Handle for Electrodes, with Interrupter (Galvano-Faradic Manufacturing Co.).

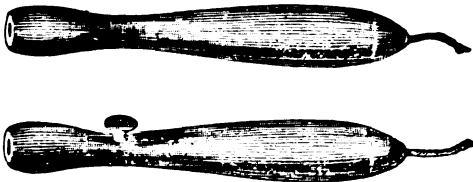

FIG. 62.

Universal Handles for Electrodes, with Interrupter—insulated (Galvano-Faradic Manufacturing Co.).

The peculiarity of these handles (Fig. 62) is, that there is no exposed metallic surface, the connection being made at the *closed* ends. A disadvantage of these electrodes is that they can be used only with one conducting wire, to which they are permanently attached.



FIG. 63.  
Long Sponge Electrode.

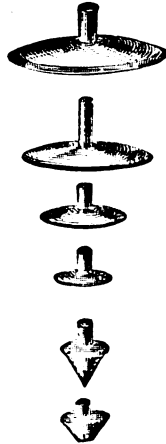

FIG. 64.  
Our electrodes of various sizes in graduated series, to be attached to universal handles (Kidder and Galvano-Faradic Manufacturing Co.).

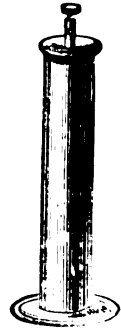

FIG. 65.  
Hard Rubber Handle and Electrode, with Interrupter (Kidder).



FIG. 66.  
Plain Wooden Sponge-holder, with Sponge attached (Kidder).



FIG. 67.  
Small Sponge Electrode (Kidder).



FIG. 68.  
Duchenne's Electrode.



FIG. 69.  
Rockwell's Brass Ball Electrode for General Faradization (Kidder).

A large, soft sponge, loosely folded about this ball, makes the most convenient possible electrode for general faradization.



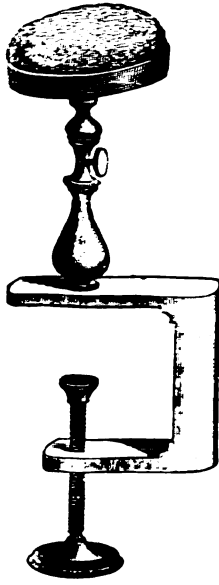

FIG. 70.

Beard's Stationary Electrode (Galvano-Faradic Manufacturing Co.).

This can be screwed to the edge of a table. The sponge at the top can be unscrewed and moistened. In many applications to the ear

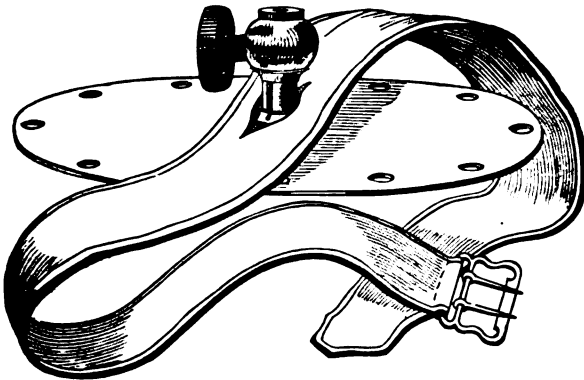

FIG. 71.

Adjustable Electrode, with Band—(Kidder).

eye, head, and face this is a most convenient electrode for the hand of the patient to rest upon.

These adjustable electrodes, which are made of several different sizes, have long been to us indispensable. They can be fastened by means of a simple cloth band to any part of the body, and kept there as long as may be necessary.

In diseases of the skin, in rheumatism, in sprains, and in tumors, and in all cases where it is desired to keep the electrode long in one spot, they are most convenient. A second advantage which they have, is, that they can be passed easily under the clothing, thus saving much undressing on the part of the patient.

These adjustable electrodes can be covered with a sponge, which can be sewed through the hole at the edge, or what is very much better, with electrode covers, to be hereafter described.

We use these adjustable electrodes in central galvanization, galvanization of the cervical sympathetic, and brain and spine, and in a large variety of peripheral applications. In some applications, as in central galvanization, one electrode is adjustable, while the other held by the patient is of the ordinary form with a handle. We do not much use the bands that accompany them, preferring to hold the electrode in position by allowing the clothing of the patient to rest against it, or having the patient hold it, by a little pressure.

In galvanization of the sympathetic, for example, the adjustable electrode can be easily placed under the collar at the back of the neck, and kept there by the pressure of the clothing.

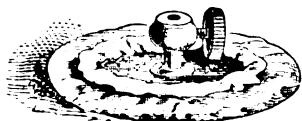

FIG. 72.  
Beard's Adjustable Electrode—small  
size—with flannel cover.

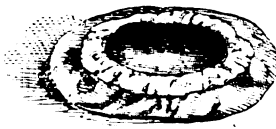

FIG. 73.  
Flannel Cover for Adjustable Elec-  
trode—small size.

These flannel covers are provided with elastics in their edges so that they remain in position when put on the electrode, and are easily slipped off and on. They can be washed like towels, and the expense of making them is so slight, that a large number can be kept constantly on hand. Another advantage of these flannel covers is that the current is more painfully felt through them than through sponges, and hence there is, while using them, less liability to give too strong currents. We have long been accustomed to use these covers in all central applications of the galvanic current.



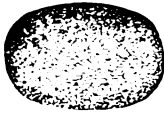

FIG. 74.

Adjustable Electrode, with sponge (Galvano-Faradic Manufacturing Co.).



FIG. 75.

Oblong Adjustable Electrode (Galvano-Faradic Manufacturing Co.).

These adjustable electrodes with sponges are very convenient for application to patients confined to bed. They may be placed under the patient against the back, or on the abdomen, or on any part of the body, without seriously disturbing the position of the patient.



FIG. 76.

Metallic brush (Kidder).



FIG. 77.

The same with brush pushed within the cylinder for protection.



FIG. 78.

Spinal Electrode. Galvano-Faradic M<sup>g</sup> Co.

*A current-reverser with flexible electrodes.*—Cut 79 represents a current-reverser recently devised and perfected, and which was first constructed by Messrs. Tiemann & Co. It is now also made by the Galvano-Faradic Manufacturing Co.

It differs mainly in this feature from other devices to accomplish the same purposes, viz. : *that the current is reversed by simple and slight*

*pressure of the thumb*, without the intervention of a slide, or any complex arrangement whatsoever.

The letter D represents the button of the spring, by pressing which, the current is interrupted or reversed. Pressing it lightly, *interrupts* the current ; pressing it firmly, *reverses* it.

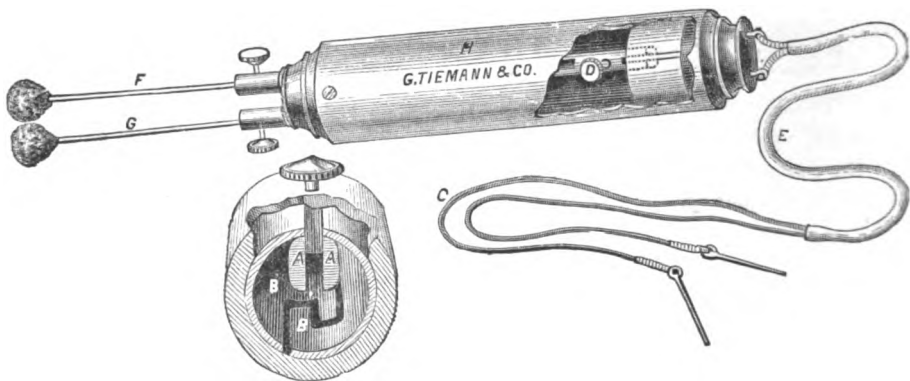

FIG. 79.

Beard's Current-Reverser, with flexible electrodes.

In the vertical section of the hard rubber handle, A A is represented as springing up against the metallic plate on the upper and inner surface of the handle. Pressing this slightly down, metallic connection is broken and the current is interrupted ; pressing it firmly down, the connection is made and *reversed* at B B, the metallic plate on the lower surface of the handle.

C represents the wires that connect with the battery, enclosed in a rubber tubing E.

F and G are flexible wire electrodes armed with sponges ; they can be separated several inches and kept there, or put close together as represented in the cut. The advantages of this are these :—1. In many of the applications of localized electrization this neat and simple arrangement saves considerable expenditure of muscle on the part of the operator. One hand can be perfectly free while the other holds and guides the electrode. In electrizing the muscles of the hand and arm, and of the face especially, it is far more convenient than to use separate electrodes.

2. In cases of paralysis of motion and of sensation, where *voltic alternatives* are sometimes indicated, this is the easiest conceivable method of reversing the current. We find the arrangement of the flexi-

ble electrodes very convenient in external applications to tumors, rheumatic joints, and sprains.

The special electrodes that are needed for local applications to special parts, as the eye, the ear, larynx, œsophagus, rectum, vagina, uterus, bladder, urethra, and so forth, will be described in the chapters devoted to the electrical treatment of these organs. We propose here to represent and describe only those that are of general use in all the ordinary applications, both of general and localized electrization.

The variety of shapes and modifications that may be given to electrodes is limited only by the taste, inclinations, and peculiarities of the operator. In describing those that we chiefly use and recommend, we do not desire to give the impression that we regard them as better than have been or may be devised by others; but simply that they have satisfactorily answered our purposes, and will, we believe, in the main be satisfactory to others.

*Unpolarizable Electrodes.*—It is well known to electro-physiologists that in consequence of the electrolytic changes that take place during the passage of a current from the electrodes to the body, a change takes place at the surface of the electrodes, by which a new electrical action is set up that to a certain extent interferes with the main current and also causes pain. Electrodes thus affected are called polarized. (See Electro-Physics, p. 31.)

Dr. Hitzig,\* of Berlin, has devised electrodes in which this secondary electrical action at the surface does not take place; to these he has given the name *unpolarizable* electrodes. These are made unpolarizable by a solution of sulphate of zinc. By the courtesy of Dr. Hitzig, we were enabled to test them while in Berlin, and were favorably impressed with their action. The pain produced by stable galvanization is sometimes very disagreeable, and by these electrodes it was certainly diminished. They can be used several hours without exhibiting any polarization. The subject of unpolarizable electrodes had previously received the attention of Regnauld, Matteucci, and Du Bois-Reymond.

*Rubber Covers for Conducting Wires.*—The conducting wires connecting the electrodes with the apparatus are covered with silk; they may be still further insulated by flexible rubber. We have long been accustomed to use these rubber covers, and are much pleased with them. If the rubber is properly prepared it will not injure the silk covering beneath it. Some electro-therapeutists have rubber coverings

\* Ueber die Anwendung unpolarisirbarer Electroden in der Electrotherapie. *Berliner Klinische Wochenschrift*, 1867, No. 89.

of a different color for the two poles, thus affording a ready means of distinguishing them.

*Care of Electrodes.*—Electro-therapeutics is a series of details ; and among the more important of these details is the care of the electrodes. The chemical action, even of the secondary coil and faradic current, is sufficient to corrode any metal that is used, except platinum ; and platinum electrodes are rarely, if ever, used except in electrolytic operations. The copper plates used at the feet in general faradization become more or less corroded and require occasional cleaning, in order to keep them bright. All the general and special electrodes of all kinds require occasional polishing with sand-paper, emory-paper, or whiting. It is an advantage to have the electrodes, as well as the batteries, nickelized, so as to reduce corrosion to a minimum.

The sponges that are attached to the electrodes need to be frequently washed in warm water, and those that are much used should be occasionally disinfected with chlorinated solutions. It is better, however, to make delicate and particular patients, especially ladies, supply their own sponges. But a physician who has a large general or special practice will find it very difficult, if not impossible, to keep a large assortment of electrodes, sponges, and electrode covers always separate ; and hence it becomes necessary to treat many of the patients with the same electrode. To meet this difficulty we devised the electrode covers, elsewhere described. These can be thrown off with every application and washed weekly, like towels. The expense and labor of making them is so slight that some electro-therapeutists, after using them a few times, cast them aside entirely.

*European Batteries.*—For the sake of our European readers, we give very brief descriptions of a few of the batteries that are at the present date most used by European electro-therapeutists. All who consult this book—Americans as well as Europeans—may find it of interest to compare the workmanship of the different countries. A fact which such a comparison constantly suggests is, that all advanced and active electrologists in all countries have realized the same difficulties and wants of the specialty, and have sought to overcome them by similar or nearly similar methods, and nearly all have in a greater or less measure succeeded. On the whole, with special advantages or disadvantages on both sides, the American batteries for the faradic current, the galvanic current, and for the galvano-cautery, are superior to the European.\*

\* For the electrotypes of the cuts that accompany these descriptions of the English apparatus we are indebted to the kindness of Dr. Althaus. The descriptions are condensed from the third edition of his treatise on Electricity.

This is enclosed in a small mahogany box, six inches high, three and a half inches deep, and six inches wide. It is run by a zinc-carbon cell. The primary and secondary currents are obtained without shifting the position of the wires.

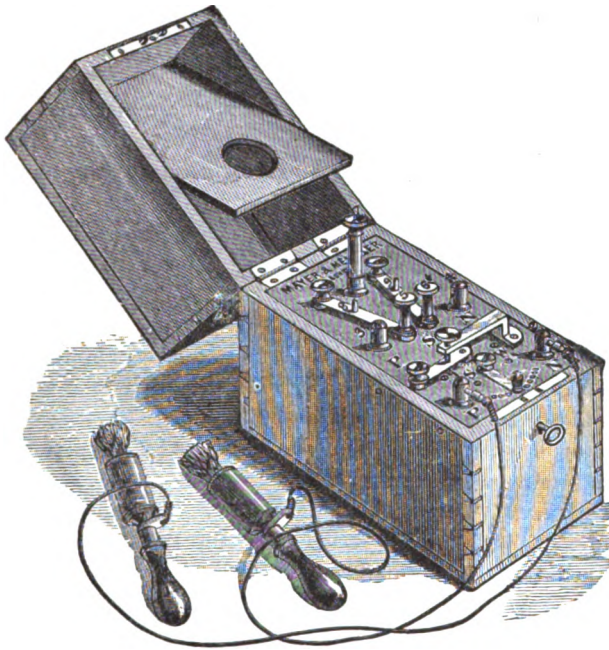

FIG. 80.

Meyer and Meltzer's Faradic Machine.

*Stöhrer's Faradic Machine.*—This well-known separate-coil machine, which is run by a zinc-carbon cell, is widely used in Europe.

*Duchenne's faradic apparatus* is of the separate-coil variety; it is inferior in portability and convenience to many other European as well as to the American machines. It is run by a Bunsen's cell.

*Legendre's faradic apparatus* is popular in France, on account of its portability and cheapness.

*Gaiffé's faradic apparatus* is very portable, and gives a fair strength of current. He has made two forms of faradic machines, one run by a chloride of silver element, and the other by a sulphate of mercury element.

*Du Bois-Reymond's faradic apparatus*, or "sledge," as it is called, is run by an element of Grove or Bunsen. It is provided with a "galvanic key" for opening and closing the circuit at pleasure. The machines of Benedict and of Siemens-Halske are modifications of that of Du Bois-Reymond.

Krüger & Hirschmann, of Berlin, have constructed a good faradic machine, which is run by a Lechanché element. It is arranged for slow or rapid interruptions.

So far as we are able to learn, none of these machines have any special advantages over those of American manufacture previously described, and some of them are much inferior to the most recent American improvements.

*Stöhrer's Zinc-carbon Galvanic Battery*.—Dr. Emil Stöhrer, of Dresden, is the pioneer in the art of making convenient and trustworthy galvanic apparatus for electro-therapeutists. He makes combinations of zinc-carbon cells, both portable and non-portable. He was, we believe, the first to devise convenient and simple current-reversers and current-selecters. These batteries have the disadvantage of all zinc-carbon batteries, that the carbons are friable. They also polarize rapidly, though not so rapidly as Smee's cell, and if the plates are kept long in the solution the current becomes very weak.

*Foveaux's battery* (Fig. 81), which is quite portable, consists of from twenty to fifty small Smee's cells. It is furnished with a switch, by which any desired number of elements can be brought into the circuit. It is provided with a dial or current-selector, for bringing any number of cells into the circuit. The jars are made of hard rubber or porcelain. The tray containing the jars is lifted and let down at pleasure. This battery is much used in England. It has, however, the disadvantage of all constructions of Smee's cells, that it rapidly polarizes and weakens. We prefer similar combinations of zinc-carbon cells.

*Becker-Muirhead or Siemens-Meidinger Stationary Galvanic Battery*.—This battery, which is highly praised by Althaus, consists of fifty modified Daniell's cells. No acid is used in it, but only water for the zinc surface and sulphate of copper for the copper surface. The cells, which are quite large, are kept down cellar, and contained in two boxes. The advantages of this battery are, that on account of no acid being used the chemical action is very feeble, and polarization is reduced to a minimum; and that, like the Cabinet battery, on account of its steadiness of action, it is better adapted for nervous and irritable patients than the small batteries.

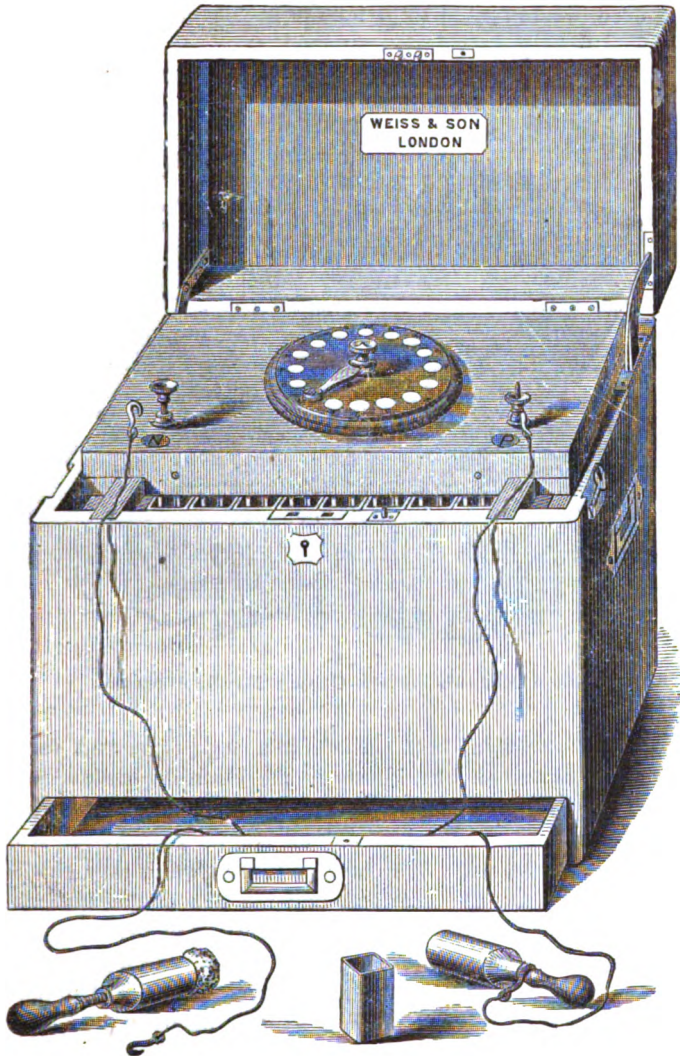

FIG. 81.  
Foveaux's Portable Galvanic Battery.

*Remak's Stationary Galvanic Apparatus.*—In Germany, this apparatus, composed of sixty cells of Siemens-Halske modifications of Daniell's battery, is much used. It is provided with a galvanoscope, a current-selector and a current-reverser. This apparatus, though very



good indeed, would appear to be inferior in convenience to the American Cabinet battery, previously described.

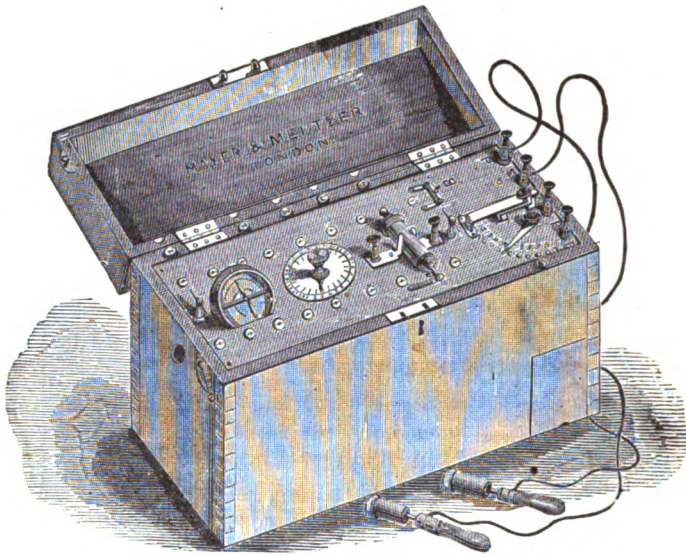

FIG. 82.

Mayer &amp; Meltzer's Portable Galvano-Faradic Apparatus.

The idea of combining both currents in a single apparatus seems to have occurred almost simultaneously to the electrologists and mechanics of Europe and America. The practical advantages of any combination that has yet been offered are not, for *portable* use at least, so great as was expected. The galvanic current which they give is apt to be too feeble for all occasions, and the size of the apparatus is much larger than is needed for the faradic current alone.

This apparatus of Meyer & Meltzer is provided with a galvanoscope, current-selector and current-reverser. It is so arranged that the first or the last portion of the cells may be used at pleasure, thus avoiding the disproportionate use of the first portion. Zinc-carbon cells are used, and they are raised and depressed as in the American zinc-carbon batteries.



## CHAPTER IX.

### LOCALIZED ELECTRIZATION.

*The object of localized electrization is to confine the direct action of the current, so far as possible, to some particular part of the body.*

*This is accomplished by placing electrodes so that the current, in passing from one to the other, shall chiefly traverse only that particular part that is to be affected.*

Both currents may be localized in this way, hence the division of localized electrization into localized faradization and localized galvanization.

The scientific use either of localized *galvanization* or *faradization* requires as accurate as possible preliminary diagnosis of the disease.

In cases of doubt it is necessary to electrize in succession all the suspected localities until the results of treatment show conclusively that we have hit upon the seat of the disease. Accordingly, in obstinate or doubtful cases the head, the cervical sympathetic, and the spine, and in some instances the uterus or organs of the abdomen, are to be successively electrized.

In the very numerous cases of doubt also, when the locality of the disease cannot be ascertained, as well as in conditions of irritation where electrization of the seat of the disease will not be borne, peripheral applications alone are frequently of decided service. For peripheral applications both the galvanic and faradic currents are used; for central applications, chiefly the galvanic. In some diseases, as, for example, locomotor ataxia, in certain stages it is better to treat the prominent symptoms, as, for example, the anæsthesia, than the seat of the disease in the spine.

*Instruments for Localized Electrization.*—In localized electrization the same galvanic and faradic apparatus are used as in general electrization. For localized electrization in all its modifications there are needed a variety of electrodes of different shapes and sizes, to reach the various localities and accomplish the different indications.

Of the electrodes there are three general forms: *the electric hand; the metallic brush; solid metals and metals covered with sponge, flannel, linen, or chamois*, thoroughly moistened.

*Dry or Cutaneous Faradization.*—To accomplish dry faradization the portion of the skin over which the application is to be made should be wiped thoroughly dry, or, what is better still, sprinkled with some absorbing powder, as the common nursery powder; and the application may be made with the *dry* hand of the operator, or with metallic electrodes.

In dry faradization with the hand there is heard a peculiar crackling sound, which is caused by the sparks that take place as the current passes from different points of the hand to the skin.

When the dry hand is used, the operator passes the current through his own person, one of the electrodes applied to some near point by an assistant, or held in the hand by the patient himself. Solid metallic electrodes of various shapes may be used for dry electrization.

Dry electrization by the metallic brush with a strong current, faradic or galvanic, is a very painful method of application, and is to be resorted to only in those cases where there is profound cutaneous anæsthesia or in neuralgia. In all cases where there is great sensitiveness the hand is to be preferred to any form of artificial electrodes.

*Electric Moxa.*—The so-called *electric moxa* is produced by using a metallic brush, plate or point, and one moistened electrode. The dry electrode is rapidly touched to the surface where the moxa is to be made, while the other is kept firmly applied to some near and indifferent point. The surface of the skin may previously be rubbed very dry, or sprinkled with some absorbing powder.

The operation requires a current of some strength, and is exceedingly painful. It is chiefly employed as a counter-irritant in neuralgia, in which affection it is frequently successful. The electric moxa may also be produced by means of two metallic brushes, one of which is pressed on the skin.

*Electrization with Moistened Electrodes.*—When it is desired to affect the tissues lying beneath the epidermis, it is better to use electrodes covered with sponge, chamois, or flannel, *thoroughly moistened* with salt water or ordinary water.\*

The size and shape of the electrode employed must be modified according to the situation and sensitiveness of the part where the current

\* In faradization we never or but rarely use salt in the water; in galvanization it is sometimes a great advantage, because it makes the current more painfully felt, and thus prevents the use of too strong currents.

is to be localized, and also by the sensitiveness of the patient. As a rule, small, finely-pointed electrodes are required for localized faradization of single muscles, larger electrodes for large muscles, or groups of muscles, and those with the largest surface for galvanization, of the sympathetic, brain and spine.

When the current is localized by means of moistened electrodes, it diffuses itself through the body between the electrodes in various directions. The extent of this diffusion will be variously modified by the situation of the electrodes and the structure and relation of the parts that lie between them (see Electro-Physiology). It is manifest also that the density of the current, other conditions being the same, will be greatest near the electrode and least at the farthest point between them. *The strength of the current being the same, small electrodes are more painful than those with a broad surface, and metallic more than the wet sponge or flannel.* The least painful form of artificial electrode is a soft sponge, with a broad surface, and well moistened.

*Direct and Indirect Electrization.*—Two general methods of localized electrization are recognized—the *direct* and the *indirect*. In direct electrization the application is made over the muscle to be excited. In indirect electrization the application is made to the nerve which supplies the muscles. In the former method, large electrodes are preferred; in the latter, usually those which are small and pointed. The faradic current is best indicated for direct electrization, and the galvanic for indirect.

The points where the motor nerves enter the muscles are called "motor points." They have been carefully demonstrated and located by Ziemssen and ourselves.

*Definition of Terms.*—In *stable* applications both electrodes are kept in a fixed position.

In *labile* applications one of the electrodes is moved or glided over the surface; sometimes both of the electrodes are moved simultaneously.

A current is called *continuous* when it is allowed to flow in one direction without interruption. Only the galvanic current can be continuous, since the faradic is always in a condition of interruption.

A current is called *interrupted* when it is broken by removing one of the electrodes, or by some form of current-breaker in the electrode, or by any method of breaking the circuit. The faradic current is always interrupted by its rheotome, but it may be still further interrupted by removing one of the electrodes.

A current is called *uniform* when it remains of the same strength during the applications of the electrodes.

A current is called by us *increasing*, when its strength is gradually

augmented during the applications. This method possesses a great advantage in treating conditions of irritation and inflammation. It may be used with both galvanization and faradization. A much more powerful current can be borne when its strength is *gradually increased* than when it is suddenly let on in full force with the first closure of the circuit, as is usually the custom with the majority of electro-therapeutists. A current which when suddenly closed may cause unbearable pain, and, when applied near the nerve-centres, may induce dizziness and faintness, may oftentimes be borne without discomfort and with positive advantage if it is gradually increased from a very mild current. With the faradic current a mild anæsthesia is produced.\*

Increasing currents are indicated in applications to the brain, sympathetic, spinal cord, the eye and ear, urethra, inflamed joints, and to all conditions of great irritation in any part of the body.

The faradic current (of Kidder's apparatus) may be increased by slowly withdrawing the metallic tube. To gradually increase the galvanic current, a rheostat of some kind is needed. The galvanic current can also be increased by an arrangement that gradually adds to the number of elements without interrupting the current, or when a sponge electrode is used, by slowly increasing the pressure.

The term *voltaic alternatives* is applied to those applications in which the direction of the current is reversed continually, while the electrodes are kept firm. The current-reverser is a very convenient instrument for producing voltaic alternatives (see p. 324).

For electrization of muscles, labile or stable interrupted currents are preferred. For electrization of the head, spinal cord, sympathetic, and nerve-tracts and plexuses, stable continuous currents are indicated, and these again may be either uniform or increasing. Labile or stable interrupted currents are best adapted to produce muscular contractions, and cause most potent physical and mechanical effects, while stable continuous currents, whether uniform or increasing, produce the strongest electrolytic or catalytic action.

In cases where the electro-muscular contractility is not greatly diminished, it is an advantage to use electrodes with a broad surface, since thereby several motor points may be influenced simultaneously, together with a considerable extent of muscular tissue, and because they are less painful than small electrodes. In such cases the faradic current is preferable.

When the electro-muscular contractility is very greatly diminished, as

\* See an article on Faradic Anæsthesia, by Dr. A. Tripier, of Paris, in *Archives of Electrology and Neurology*, May, 1874.

so frequently happens in paralysis, contractions are best produced by small, finely pointed electrodes, applied at the motor points of the individual muscles; yet even here electrodes of moderate size are usually preferable. Such cases often require the galvanic current.

*Details of Applications of Localized Electrization.*

*Galvanization of the Central Nervous System.*—It is necessary to bear in mind at the outset, that to produce powerful electrolytic effects on the brain, spinal cord, and sympathetic, the galvanic current is preferable to the faradic, although the faradic current certainly affects the nerve-centres.

*Galvanization of the Head.*—The head may be electrized in a variety of ways, according to the supposed seat of the disease. One pole may be placed on the forehead and the other on the occiput; or both poles may be placed over the ears, or on the mastoid processes. Another method which we frequently adopt is to place the positive pole on the summit, over the supposed organ of firmness, and the other at the occiput, or under the chin.

To affect the base of the brain, the electrodes may be placed on or behind the mastoid processes. To confine the action to one side of the brain, one electrode may be placed on the forehead, over the eye, and the other on the mastoid process of the same side. The patient may hold one of the poles in the hand. Still another method less used is to place an electrode on each temple.

Less dizziness is caused if the current is opened and closed with the positive than with the negative pole. It is well, therefore, to first apply the negative pole.

Less dizziness is caused when the current flows through one side of the head, or from the forehead to the occiput, than when it is sent from one side to the other, through the mastoid processes (see *Electro-Physiology*, p. 113).

*The use of some kind of a rheostat, so as to avoid interrupting the current or giving sudden "shocks" on closing and opening, is almost indispensable in electrizing the brain and neck.* With regard to the direction of the current, it is usually better to place the negative pole nearest the neck, and the positive pole nearest the forehead. But this rule is liable to many exceptions, and each case must be studied by itself.\*

Electrization of the head produces flashes of light through irritation of retina, and dizziness, which with many is disagreeable. If the ap-

\* See remarks on polar effects, p. 102.

plication is too long continued, headache and insomnia, and general *malaise*, may result. Patients whom a short application through the head benefits, are sometimes injured when the séance is protracted. Galvanization of the head should be made with broad electrodes, with a stable current, which may be either uniform or increasing, and should not exceed from one-half a minute or three-quarters of a minute, to five or ten minutes, and with a mild current.

To all these rules in regard to the strength of currents there are exceptions. There are cases of even very delicate patients that will bear almost any amount of electricity through the head and neck.

*Galvanization of the Cervical Sympathetic.*—The portion of the sympathetic to which galvanization is chiefly directed for therapeutical purposes is the cervical, although the cephalic, thoracic, and abdominal ganglia are unquestionably affected by it, though not with so specific, demonstrable, and immediate results.

There are a number of methods by which the superior, middle, and inferior cervical ganglia may be demonstrably affected by the galvanic current.



FIG. 83.

## Galvanization of the Cervical Sympathetic

1. One electrode with an oblong extremity is placed in the auriculo-maxillary fossa, while the other with a larger surface is applied over, or by the side of the sixth and seventh cervical vertebræ (see Fig. 95).

The second electrode may also be applied at any point along the spine, from the occiput to the coccyx. It is by this method that diplegic contractions are usually produced with most success.

2. The first electrode being placed as before, in the auriculo-maxillary fossa, the other, with a surface of moderate diameter, is applied just above the manubrium sterni, by the side of the sterno-cleido-mastoid muscle (see Fig. 96).



FIG. 84.

Galvanization of the Cervical Sympathetic, including the Pneumogastric.

The second electrode may also be applied higher up in the neck, opposite the middle cervical ganglion.

The above are the two methods which have been most frequently employed. Other methods are the following.

3. The first electrode being placed as before, the other may be applied on the shoulder, elbow, or in the hand of the opposite side, or in the axilla.

4. Both sides may be galvanized simultaneously, by placing an electrode over the mastoid processes.

5. One electrode is placed just above the manubrium sterni, and the other at any point down the spine.

6. One electrode is placed over the sixth and seventh cervical vertebrae, and the other over the brachial plexus, at the pit of the stomach, just above the manubrium sterni, in either hand, or at the feet.

In all these methods either direction of the current may be used, according as calming or irritating effects are desired (see p. 281).

Concerning the physiological effects of galvanization of the sympathetic see *Electro-Physiology*, p. 128.

Applications to the sympathetic should be made from one to ten

minutes, and with from five to twenty-five cells. Several methods may be tried at a single sitting in cases where the applications are well borne.

Bearing in mind that in all such attempts to galvanize the cervical sympathetic, the pneumogastric and spine must be more or less influenced, the general indications for the use of this method of treatment to which experience would seem to point are these :—

1. Cerebral anæmia and hyperæmia. These conditions are associated with and are a part of a large variety of diseases. Insomnia, hemiplegia, tic douloureux, many diseases of the eye and ear, as neuro-retinitis, nervous deafness and tinnitus aurium, are all more or less associated with cerebral anæmia, hyperæmia, and all have been treated by galvanization of the cervical sympathetic, with more or less success.

2. Disorders of the vaso-motor nerves. Under this head may be included some cases of deficient circulation, cutaneous hyperæsthesia, and certain diseases of the skin.

3. Functional diseases of the digestive and genital apparatus. Galvanization of the sympathetic in these conditions seems to work, partly at least, by reflex action, and partly, also, by the influence which the spinal cord and pneumogastric receive during the applications.

It is scarcely necessary to remark that the *exclusive use of galvanization of the cervical sympathetic is indicated only in exceptional cases*. It is to be employed in connection or alternation with general faradization and galvanization of the brain, spinal cord, and periphery. A noteworthy advantage of this method of treatment in those cases for which it is of service is the comparatively short time required for its employment.

The objection that galvanization of the cervical sympathetic is a dangerous procedure will be considered in the chapter on central galvanization.

*Galvanization of the Spine.*—The spine may be electrized by placing one electrode at the occiput, and the other at the coccyx. One of the electrodes may be kept *in situ*, while the other is slowly passed up and down the entire length of the cord. Either pole may be passed up and down in this way according to the effect desired.

The current may also be localized in any part of the spine that may be required, by giving the electrodes the proper position. The applications may be made with ten cells and upwards, and should not usually exceed five or ten minutes. The applications should be sensitively felt, like a gentle mustard plaster, but should not be excessively painful, like a blister.





FIG. 85.

**Faradization of the Facial Nerve and Muscles. Eyelid firmly closed and mouth drawn to one side.**

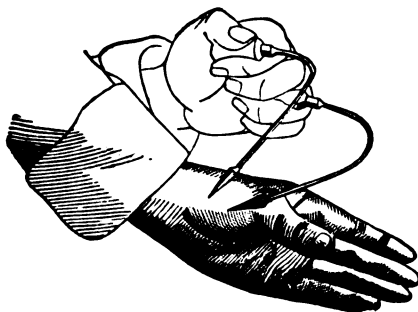

FIG. 86.

**Muscular Faradization with metallic electrodes (Duchenne).**

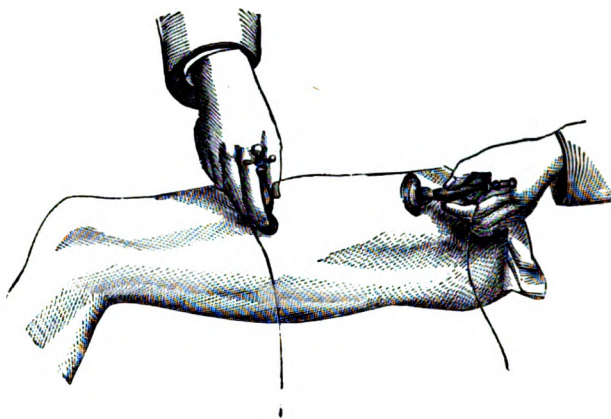

FIG. 87.

Faradization of the Muscles of the Thigh, contraction of the quadriceps.

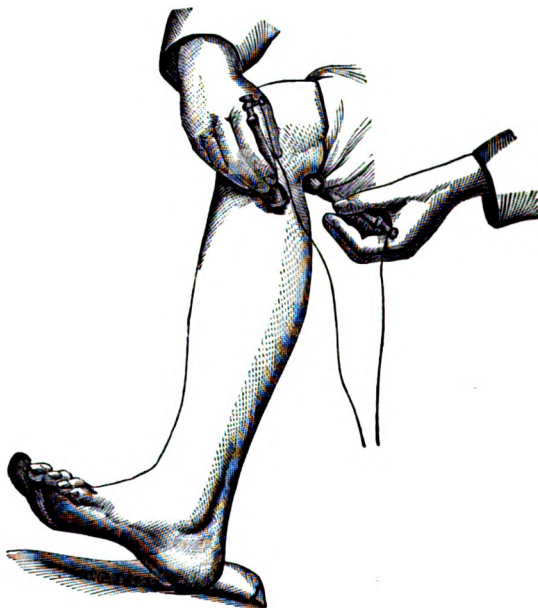

FIG. 88.

Faradization of Popliteal Nerve and Peroneal Muscles. Foot brought upward and outward.

*Electrization of Plexuses, Nerves, and Muscles.*—Plexuses, nerves, and muscles are treated by both currents (see chapter on differential indications for the use of the galvanic and faradic currents).

One electrode may be applied to a plexus and the other to one of its branches, or to a muscle or group of muscles. Both electrodes may be applied to the nerve, or one to the nerve and the other to a muscle; or both may be applied to a muscle or group of muscles. All these applications may be made either with or without regard to the direction of the current, and different methods may be tried at the same séance.

In all the positions described in the above cuts, contractions should be produced with mild faradic currents, when the electrodes are in the position represented. *If very strong currents are necessary or no contractions are possible, the muscles are in a condition of disease.*

*Peripheral applications are indicated where the disease is purely of a peripheral character; the partly central applications are indicated where the disease is of a central origin.*

Labile interrupted applications are indicated where it is desired to produce mechanical effects or muscular contractions, as in anæsthesia and paralysis.

Stable continuous applications are indicated where it is desired to produce electrotonic, chemical, or catalytic effects, as in neuralgia.

Benedikt\* makes the following somewhat over-refined subdivisions of the methods of *galvanization* of the centre and periphery :

*Spinal-cord current* : both poles are placed on the spine, either near together, or at some distance from each other.

*Spinal-cord-root current* : one pole is placed on the spine, and the other is passed up and down by the sides of the vertebræ.

*Spinal-cord-plexus current* : one pole is placed on the spine, and the other on a plexus of nerves.

*Spinal-cord-nerve current* : one pole is placed on the spine, and the other on a nerve.

*Spinal-cord-muscle current* : one pole is placed on the spine and the other on a muscle.

*Plexus-nerve current* : one pole is placed on a plexus of nerves and the other on a nerve.

*Nerve-muscle current* : one pole is placed on a nerve and the other on a muscle.

These currents may be either *stable* or *labile*, *continuous* or *interrupted*, *uniform* or *increasing*.

\* Op. cit., p. 56.



FIG. 89.  
Spinal-cord-brachial plexus current.



FIG. 90.  
Spinal-cord-median nerve current.

The method of electrizing the eye, ear, nose, larynx, œsophagus, heart, lungs, stomach, liver, kidneys, spleen, intestines, rectum, bladder, male and female organs of generation, will be described in the chapters devoted to diseases of these organs.

The method of electrizing individual nerves and muscles has been described and illustrated in the chapter on electro-therapeutical anatomy.

*Effect of Current modified by the Length of Application.*—The sensations and the effects of electrical applications are considerably modified by the length of time that the electrodes are kept in position. When the *faradic* current is first applied to the skin, it causes a stinging, pricking sensation, perceptibly strongest at the negative pole; if the electrodes are kept in position the sensation may gradually diminish, and the parts will become very slightly benumbed, and if now the strength of the current be *gradually* increased, little or no additional pain is caused. If the current is at first very strong, it cannot be borne long enough to produce this benumbing effect.

When the *galvanic* current is first applied to the skin it causes no sensation or scarcely any, unless it be very strong or is directed over or near a motor nerve; if the electrodes are kept in position for a few seconds, a slight burning sensation is felt at both poles, but strongest at the *negative*. This burning sensation increases quite rapidly until the sensation it causes is like that of a strong mustard plaster, or hot iron, and becomes unendurable. The benumbing effect of the faradic current is not experienced. The fact that the galvanic current is but little felt at first, leads those physicians who have not been accustomed to it to use it altogether too strong. This increase of the pain under the galvanic current is due to two causes—the moistening of the skin through the moisture of the electrode, so that it becomes a better conductor of electricity, and the special chemical action of the poles (see *Electro-Physiology*, p. 181). This increased conductivity of the skin is the partial if not complete explanation of the fact that the muscles contract under a feebler current after the electrodes have been some time in one place. It is not impossible, however, that the nerves or muscles may be so stimulated by the current as to contract more readily than before stimulation.

The reverse proposition, that strong currents used for a long time enfeeble the nerves and muscles so that they respond less readily to the current, is certainly true, and is easy of demonstration, especially in cases of facial paralysis. For this reason, prolonged applications frequently do more harm than good.

*Effects of Localized Electrization.*—Localized electrization has to a limited extent the same direct effect on the part to which the application is made that general electrization has on the whole body. It acts as a locally stimulating tonic.

*Improvement in Local Nutrition the leading effect of Localized Electrization.*—The leading and general effect of localized electrization, and one which is a complex result of the various special effects, is *improvement in local nutrition*.

Localized electrization of an atrophied or poorly nourished muscle causes that muscle to improve in size and strength ; localized electrization of an atrophied or poorly nourished organ, as the uterus, causes it to increase in size and improve in functional activity.

Localized electrization of any part of the cerebro-spinal system improves the nutrition of that part, and as a result the whole body, over which the cerebro-spinal system presides, may improve in nutrition. Thus localized may indirectly have some of the same effects as general electrization. Similarly, also, as we descend from the centre toward the periphery electrization of any nerve branch or plexus improves the nutrition, not only of the nerve acted on, but also of its various branches, and of the muscles and organs that it supplies.

When the nutrition of an atrophied part is improved it grows larger ; when the nutrition of a hypertrophied part is improved it grows smaller. The same treatment that makes a flabby muscle increase in size causes a goitre to diminish in size. These opposite effects of the local use of electricity, though apparently inconsistent, are yet quite consistent (see Electro-Physiology, p. 191 ; and Electro-Surgery, chapter on Tumors).

The *special* effects of localized, unlike those of general electrization, cannot be broadly stated or classified, for the obvious reason that they must so largely depend on the locality to which the application is made.

Although applications to the central nervous system are sometimes followed by mild and limited degrees of the primary, secondary, and permanent effects that result from general faradization or central galvanization ; yet the cases where the full order of these effects is so marked and decided as to be observed are comparatively unfrequent.

Applications to the brain and sympathetic system may be followed primarily by relief of pain, slight exhilaration, a feeling of warmth or somnolence ; secondarily by fatigue, headache, or soreness of the muscles, or exacerbation of the morbid symptoms ; and permanently by improvement in sleep, strength, and capacity for labor.

But this *order* of effects from localized electrization is exceptional, even from applications made to the head. More frequently the permanent effects are experienced without the primary, or perhaps both the permanent and secondary, and sometimes only the latter.

Yet none of these constitutional effects, in whatever order they may occur, are experienced to the extent that is derived from general faradization.

The agreeable symptoms which are most frequently observed after localized applications to the nerve-centres are *disposition to sleep, relief of headache or other pain*, and occasionally *slight exhilaration*.

Sometimes the beneficial results of electrization of paralyzed muscles follow immediately after the application. The patient is conscious of an ability to use the muscles treated with greater ease and freedom. This improvement may be merely temporary, or, as is more frequently the case, partial relapses occur, leaving a certain amount of permanent benefit. Immediate relief of neuralgic pain, and of the reverse condition, anæsthesia, may follow localized as well as general electrization. The temporary relief of the neuralgia may be complete, while that of anæsthesia is usually only partial and limited. In both conditions the evil symptoms may recur, or a certain amount of permanent benefit may remain.

Among the disagreeable symptoms are *dizziness, heaviness, oppression, headache, soreness in the muscles, exhaustion, and indefinable nervousness.*

These disagreeable symptoms are most likely to result from applications that have been either too severe or too protracted for the condition of the patient; and yet they should by no means excite alarm, since they often accompany the most successful results. These unpleasant symptoms are more likely to follow the use of the galvanic current than the faradic, especially when the applications are protracted. The opinion that has been expressed by certain writers, that the head is more likely to be unpleasantly affected by the faradic than the galvanic current, is not sustained by experience. The phenomena of dizziness, heaviness, etc., frequently experienced after even a very short application to the head, are but rarely observed when the faradic current of a continuous-coil apparatus is employed, with a large soft sponge, or the hand of the operator.

Applications of localized electrization to individual muscles or groups of muscles rarely give rise to any constitutional symptoms whatever, unless the electrodes are placed on or near the head.

The special effects of localized electrization of special organs, as the eye, ear, larynx, stomach, liver, intestines, uterus, ovaries, bladder, etc., will be described in the chapters devoted to the treatment of the diseases of these organs.

*Absolute Localization of Electricity impossible.*—It should be considered that *exclusive and absolute localization of the effects of electrization is impossible.* The effects of both currents extend, either directly or by reflex action, to parts beyond the circuit. This is demonstrated, not only by physiological experiments, but by the observed facts of clinical experience. Thus it is observed, in some irritable conditions, that galvanization of the spine, and even of the extremities, causes a metallic

taste ; that galvanization even of the hands or feet sometimes hastens or increases the menstrual discharge, relieves headache, and produces sleep. The same effects to a less degree are sometimes observed from faradization.

Some of the illustrations of this fact are quite striking. Thus in the case of the wife of a physician whom we were treating by faradization of the shoulder for rheumatism, the menstrual flow was so much increased and prolonged that it was necessary to abandon the treatment, although only very mild currents and short applications were used.

In the case of a lady whom we were treating for sciatica, by localized galvanization of the painful portion of the nerve, the pain was decidedly relieved, but the effect was to bring on a recurrence of the menses after they were suspended, so that the patient was nearly all the time menstruating.

These illustrations are extreme and comparatively rare, but they serve to show clearly enough that the effects of electrization cannot well be localized to the points between the electrodes, and that other and distant parts must, of necessity, be more or less affected.

The term *localized* electrization, introduced by Duchenne, is therefore, strictly speaking, a misnomer, since we are taught by physics that the vibrations of the electrical force must diffuse themselves in various directions, and at a considerable distance from the electrodes, and we are taught by clinical experience that the *effects* of electrization, however near together the electrodes may be placed, are not entirely confined to the points between or near the electrodes, but may be felt, and in some instances far more demonstrably, in distant parts and organs.

To the use of the term localized electrization, there is no objection, provided it be used understandingly, and with the idea that it is merely a term of convenience. The term local electrization is often used synonymously with localized electrization, and for the reasons here suggested is preferable to it. Localized electrization has the advantage of being first in the field, and has become, to a certain extent, consecrated by usage.



## CHAPTER X.

### GENERAL FARADIZATION.

*The object proposed in general faradization is to bring every portion of the body under the influence of the faradic current, so far as is possible, by external applications. This is best accomplished by placing one pole (usually the negative) at the feet or the coccyx, while the other is applied over the surface of the body.*

The faradic is the current which is almost exclusively employed in general electrization, and, for that reason, the directions and explanations given in this section, with the exceptions that will be noted, apply mainly and specially to general faradization. Since the discovery of central galvanization, to be hereafter described, we have discarded the term general *electrization*, and substituted general *faradization*, for the reason that the galvanic current is preferably used in the form of central galvanization.

In the majority of cases it is more convenient and satisfactory to have a sheet of copper at the feet. This position is indeed the rule in general faradization. The broad, callous soles of the feet are but slightly sensitive, and will bear a stronger current than any other portion of the surface of the body. But the passage of electricity through the ankles causes vigorous contractions of the flexors and extensors, which, when the current is very strong, may be somewhat painful. Accordingly, when the patient is peculiarly nervous and sensitive, or when a current of unusual strength is to be employed, and in all cases where a stronger application is desired than can be borne through the ankles, or when it is desired to save time or inconvenience, it is advisable to have the patient sit on the plate, or a sponge electrode with a broad surface may be applied to the coccyx.

In general faradization, as in localized, the currents may be *stable* (stationary) or *labile* (moving), *uniform* or *increasing*.

*Increasing* currents are adapted for certain important centres, as the head, spine, cervical sympathetic, and cilio-spinal and epigastric regions.

The advantage of this method of application is that it allows the use of a stronger current than will otherwise be borne; the strength of the current may be so very gradually increased that the increase within certain limits may be almost imperceptible to the patient. This arises partly from the fact that the current has a slight benumbing or anæsthetic effect (see Electro-Physiology, p. 111), and partly from the fact that by a gradual increase of the strength of the current the patient is spared the shock that is experienced when a strong current is suddenly directed through sensitive portions of the body.

*Labile* and *interrupted* currents are adapted for the muscles, especially of the extremities.

*General faradization* is very far from being so easy a process as it might appear from this brief description. Its successful employment requires, on the part of the operator, some mechanical dexterity, entire familiarity with the instruments required, a complete knowledge of electro-therapeutical anatomy; a personal acquaintance with the sensations and behavior of all portions of the body under the different electric currents; close and patient study of the diseases and morbid conditions in which it is indicated, and of their response to faradization. There are those who by long practice are enabled, when necessary, to readily manipulate any portion of the body with either hand, while there is passing through them a current so powerful as to keep many of the principal muscles of the arms in a state of contraction. This qualification, however, though convenient, is not indispensable.

On the side of the patient, success in the use of general faradization requires something of the same patience and perseverance that are conceded to be necessary for success in the use of any other form of electrical treatment.

Nothing is more difficult than to fully and accurately describe in words an operation that in its very nature demands actual sight and experience. The true method of learning the art of general faradization is by repeated observations of its application to the *living* subject, by personal experience of its sensations and results at the hands of practised adepts, and by long and various experimenting on diverse temperament, and in opposite states of disease. We shall endeavor, however, to present the best possible substitute for a course of private lessons or extended clinical observation in this department, by answering in detail the practical questions that naturally present themselves to one who approaches the subject *ab initio*, and who has no opportunity for personal interviews with those to whom the various steps of the operation have become already familiar.

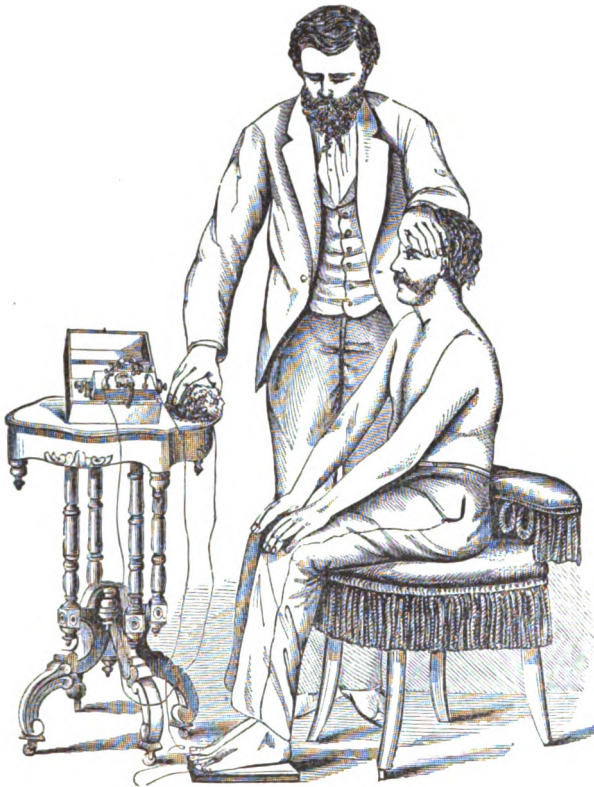

FIG. 91.

**GENERAL FARADIZATION**—application to the head by the hand of the operator. (In this, as in all of the cuts of general faradization, for convenience of illustration the patient is represented without any covering. In the majority of cases they are protected by a shawl or wrapper, and frequently the underclothing is not removed.

*Position of the Patient.*—The patient should be seated on an ordinary stool, with his face toward the instrument, and his feet on the sheet of copper to which the negative pole is attached. Any chair that has a back or arms will somewhat interfere with the manipulations of the operator.

Those patients who, through paralysis or debility, are unable to sit up at all, can receive the treatment while lying in bed or on a lounge.

In such cases the sheet of copper may be placed upright against a pillow, and the feet of the patient pressed against it, or an electrode may be placed at the coccyx. Assistance will then be required to turn the patient when the application is made to the back and spine, but in such cases partial applications are frequently all that are required.

Infants and very feeble or very timid children should be held in the lap of the mother or nurse, while an assistant holds the sponge to the coccyx.

While the application is being made to the lower limbs it is well for the patient to stand, in order that the operator may have access to the gluteal regions and the posterior and anterior surface of the thigh.

*Position of the Operator.*—While making applications to the trunk, the operator may either stand or sit by the side of the patient, conveniently near to the table, on which are placed the apparatus, electrodes, sponges, bowl of water, and other appliances that may be called for during the application.

While operating on patients taller than himself the operator will find it easier to stand, especially while treating the head and upper portion of the trunk. While treating short patients the operator will find it less fatiguing to sit in a chair. Most operators will find it very convenient to change their position from a sitting to a standing posture, or from one side of the patient to the other, while making the applications to the various parts of the trunk.

*Minor Apparatus.*—Electrodes, sponges, and copper plate.

The best electrode for the pole that is applied over the patient is a brass ball of about one inch in diameter.

Around this brass ball should be loosely folded a soft wet sponge, of about six inches in diameter. This is found, by experience, to be by far the most convenient form of artificial electrode that can be devised. Next to the moistened hand of the operator it is the most agreeable to the patient of any shape or quality of electrode. The sponge can be pressed or folded over the brass ball so as to make a comparatively small electrode, or its entire surface may be applied.

When the operator allows the current to pass through his own person, and uses his hand as an electrode, holding the sponge and ball in his other hand, he can modify the application to any degree of strength or mildness that he may desire, by simply increasing or diminishing the pressure of his hand or fingers on the sponge. Used in this way the sponge holding the water acts like a hydro-rheostat (see p. 319). When it is necessary that the application should be particularly gentle and cautious, it is well to rest the ball and sponge on the table,



FIG. 92.

**GENERAL FARADIZATION**—application to the spine. The hand of the operator is on the metallic tube, in a position to increase or diminish the current as may be needed.

and to begin the treatment by first pressing one hand *firmly* over the part desired to be affected, and with the other lightly and delicately touching the sponge, at first with one finger, then with two, three, and four successively, and finally with the whole hand, thus giving a very gradually *increasing current*. Raines' electrode, which is a sponge covered at the back with rubber, is very convenient for general faradization.

A *piece of copper plate* is recommended for the negative electrode, because it is found by experience to be, on the whole, more conve-

nient than any other arrangement that has yet been suggested. The bowls of warm water, large sponges, etc., that have been suggested, are not only much less cleanly and convenient than the copper plate, but are also much poorer conductors. Metallic slippers are more troublesome than the broad plate, though their appearance, perhaps, is more ornamental. It needs more care to put on the slippers, and if the patient loses his self-control during any stage of the application, and throws up his feet, it is something of a task to find the slippers again and accurately adjust them.

In the use of the copper plate these details must not be forgotten: *First*, to keep it well warmed, in cold weather, by a piece of heated soap-stone beneath it; *secondly*, to keep it slightly moistened with warm water, in order to improve the connection.

If only one foot is applied to the copper plate, the pain in the ankle, during certain stages of strong applications, will be unendurable. In mild applications it is sufficient to have one foot on the plate. It is necessary ever to bear in mind the rule, that the pain of electrical applications, other conditions being equal, is in *inverse* proportion to the surface of the electrode. The *larger* the surface of the electrode—whether positive or negative—the less the pain. In this fact consists the advantage of using large sponges.

In general faradization the pain at the negative pole is chiefly felt at the ankles, and somewhat at the toes, but not on the bottom of the feet. The feeling of constriction in the ankles is caused by the rapid and violent contractions of the muscles. If only one foot is applied to the plate the entire force of the current must, of course, be borne by that foot, and furthermore, the other limb will receive no direct benefit from the treatment.

The trouble of removing the shoes and stockings may be obviated by placing a large sponge connected with the negative pole at the coccyx, or on the thighs.

*Facility, skill, and readiness in use of the various methods of modifying the strength and quality of the current is one very important secret of success in the use of general faradization. A skilful operator will cause less discomfort with a strong current than one who is awkward will cause with a very weak current.*

*Details of the Applications to the Different Parts of the Body.*—As the various parts and organs of the body differ very widely in their susceptibility to faradization, and in the effects which they receive from it, it becomes necessary to explain the *modus operandi* of the applications with considerable fulness of detail.

*Applications to the Head.*—The head, especially the forehead, is, by far, more sensitive to the electric currents than any other portion of the surface of the body. The *two* reasons for this are sufficiently obvious. The surfaces of bones are always sensitive to the *faradic* current, as to any other mechanical influence; and the cranium is no exception to this law. Then, again, the fifth pair is an exceedingly sensitive nerve in all its ramifications, and especially over the forehead.

There are many cases that do not bear even mild applications to the front and top of the head, and who seem to be injured rather than benefited by it. With others, the effects are highly agreeable.

In treating the forehead the operator should first press his moistened hand firmly over the head, and then making the connection with his other hand on the sponge and brass ball of the positive pole, should allow the current to pass steadily, without interruption, for one or two minutes. In Kidder's faradic apparatus, A B is the best current for the forehead. The use of the hand as an electrode is particularly desirable in making applications to the forehead.

*Moistening the Hair.*—The dry hair is a non-conductor, and therefore it is always necessary to *wet it freely before electrizing* any portion of the head that is covered by it. It is not usually desirable to compel lady patients to pull down their hair, or to thoroughly moisten it. A very important centre for affecting the brain is the crown of the head, between the ears, over the so-called organ of firmness,—the cranial centre. If the hair at this point be sufficiently moistened to admit the passage of a mild current with any convenient form of electrode, a peculiar and slightly painful sensation is experienced.

In some exceptional cases of disease the head will bear currents of considerable strength. The back of the head over the cerebellum will usually bear quite strong applications. The current is felt through the ramifications of the occipital nerves, giving rise oftentimes to sensations not only painless, but absolutely agreeable.

*Applications to the Neck and Throat.*—The back part of the head and upper portion of the spine will usually bear powerful applications. It is an interesting and important fact *that very marked effects may be produced by general faradization, even when the applications are made only to the back and sides of the neck.*

The reason for this will be clear when we come to study the *electro-therapeutical anatomy* of the parts. From the upper portion of the spine and base of the brain proceed the most important and most sensitive nerves of the body—the pneumogastric, and the brachial plexus, and the phrenic nerves.



Furthermore, the sympathetic or ganglionic system runs close by the spine, near to the carotid artery, and may be reached and affected electrically by pressing firmly with the fingers, by the anterior border of the sterno-cleido-mastoid muscle, at those points where the pressure of the carotid is most readily felt.



FIG. 93.

**GENERAL GALVANO-FARADIZATION.**—Application to the spine by a sponge holder. A double electrode is used, one part of which is connected with the galvanic and the other with the faradic apparatus. The copper plate is also connected with both currents. Galvano-faradization we do not now employ, but the cut illustrates perfectly one of the steps in general faradization.

If the sponge be pressed firmly on the cilio-spinal centre, over the sixth and the seventh cervical vertebræ, and moved slightly on either



side of the spine, while a powerful current is passing, the electric influence may be *perceptibly* communicated, not only to the spine but also to the larynx through the laryngeal nerves; to the stomach through the pneumogastric; to the lungs through the phrenic; to both arms and hands through the brachial plexuses and their branches—*in short, to the most important nerves and organs of the body.* The sympathetic is also directly affected at this point.

There is no other single place on the surface of the body where the electrical influence can be communicated to so many important nerves as at the cilio-spinal centre. In order, however, to affect all these nerves and organs above mentioned by faradization it is necessary to use a powerful current, and to press the sponge very firmly against the skin.

In very fleshy patients it is sometimes quite difficult to affect the brachial plexuses and their branches in the arms and hands without using a stronger current than can well be borne through the feet and ankles at the negative pole. This application, so far from being painful, is to many positively agreeable. The *thrill* which it communicates to the nerves and vital organs is often so delightful that the patient requests to have the application prolonged. In patients who can bear it, this application at the cilio-spinal centre may be varied by suddenly interrupting the current.

This application is a very important factor in general faradization, and will achieve decided tonic effects on the system, even when no other portion of the body is touched by the current. The immediate sensations which it produces, however, are by no means uniform. Some patients, through the irritation of the laryngeal nerves, cough spasmodically, and even violently, under the excitation even of a comparatively mild current; with others, even the most powerful currents, and the firmest possible pressure of the sponge, fail to produce any such effect. In nervous and sensitive patients this application often causes a peculiar and decided sensation in the stomach, through the pneumogastric nerve; the strong and vigorous rarely experience any such sensation, even under currents of great power.

Another important locality in the electro-therapeutical anatomy of the neck is in the posterior triangle, just by the posterior border of the sterno-cleido-mastoid muscle. If the fingers of the operator, with a current of considerable strength, or the sponge with a current comparatively mild, be pressed firmly on this space until the posterior border of the scalenus anticus is reached, the patient will at once experience a tingling or pricking sensation in the arm and hand on that side, caused

by the excitation of the brachial plexus, and in some cases a thrill is communicated by means of the pneumogastric to the stomach, and by the phrenic nerve to the diaphragm.

*Applications to the Upper Extremities.*—It is not always necessary to go to the trouble of faradizing the extremities, but in many cases it is a decided advantage to do so. In faradization over the extremities, the sponge, or the hand of the operator, should be passed thoroughly over the surface of the hands and arms, and with sufficient force to produce agreeable contractions of all the superficial muscles. Except in infants and corpulent females, contractions of the superficial muscles of the arm are obtained with a mild current.

*Applications to the Spine.*—Stronger currents of electricity may be borne over the middle of the spine than perhaps over any other portion of the body. There are no very sensitive peripheral nerves in the back, and the spinal cord is so thoroughly protected by its bony covering that the currents are never felt in it painfully, except when it is greatly exhausted or organically diseased. The nerves that issue from the spinal cord are more or less affected by powerful applications to the back, and through them the various parts and organs which they supply are considerably influenced.

The best method of electrizing the back is to pass the sponge down its entire length beneath the under-clothing, in case it is not removed, from the first cervical vertebra to the *cauda equina*, carefully avoiding the prominences of the scapula and the ossa innominata. Below the inferior angle of the scapula the sponge may be moved from side to side over the region of the kidneys, liver, and spleen.

If a strong current be applied over the lower portion of the spine, between the upper borders of the ossa innominata, a slight sensation is sometimes, though by no means uniformly, communicated to the rectum and the male genital apparatus, the penis and the testicles, through their spinal nerve-supply.

In view of these considerations it is manifest that in the *employment of general faradization particular attention should be given to the spine, even at the expense of neglecting other portions of the body.*

That the lungs and heart are less influenced by electrization than other important organs, is chiefly accounted for by the anatomical structure of the chest. The ribs, with the intercostal muscles and ligaments, form an unyielding wall. Furthermore, the pleura and pericardium are not closely adherent to the inner wall of the chest, but lie loosely over the lungs and heart. These organs, therefore, are best affected electrically by applications above the sternum, around the neck, and over the upper

half of the spine, whence the nerve-supply of the viscera proceeds, and by direct electrization of the vagus in the neck.

Applications over the chest are, however, of positive and permanent service, by developing the thoracic and intercostal muscles, and for this reason, if for no other, they should not be neglected. But it should not be forgotten that the surfaces of the ribs, like the surfaces of all other bones, are sensitive to electrization, and that therefore the chest will not bear as severe applications as the spine, neck, or abdominal regions. This sensitiveness is, of course, more in the thin and nervous than in the corpulent and phlegmatic. It is usually most marked on the *inferior ribs on the right and left side of the body*, over the liver and spleen. The peculiar sensitiveness of the ribs at these points is sometimes erroneously supposed to indicate disease of the organs beneath them.

We have stated above that the anatomical structure of the chest rendered it difficult to send the electric current through its anterior walls to the lungs and heart. In the abdominal regions the anatomical structure is directly reversed, and instead of an unyielding wall, partly composed of bones and ligaments, we have a flaccid skin lying loosely against the peritonæum that covers the moist viscera beneath. No other organs of the body contain so large a percentage of water as those which are situated in the cavity of the abdomen. It is obvious, therefore, that when the resistance of the epidermis is overcome by the moisture of the sponge or hand, and the peritonæum and viscera are brought into coaptation, the current must directly traverse all the parts desired to be affected.

To reach the stomach and solar plexus, place the sponge or palm of the hand below and under the sternum, and as far back as possible. This pressure brings the peritonæum and stomach into coaptation, and forces the current to pass through them. If the under-clothing be simply slipped up without being entirely removed, the stomach and abdomen can be readily treated.

The bowels may be treated either with the labile or the stable current, and, in cases of obstinate constipation, by sudden interruptions or shocks.

Corpulent and pury patients usually bear much stronger currents over the abdomen than the thin and emaciated. Adipose tissue is comparatively a poor conductor of electricity, and it is difficult to affect the bowels of the very corpulent through the abdominal walls by electrization, unless we employ firm pressure and currents of considerable strength. But in the vast majority of cases currents of moderate

strength, applied lightly over the surface of the abdomen, will readily produce contractions of the abdominal muscles, and, if pressure be employed, the intestines and all the organs of the abdominal cavity are directly traversed by the current.

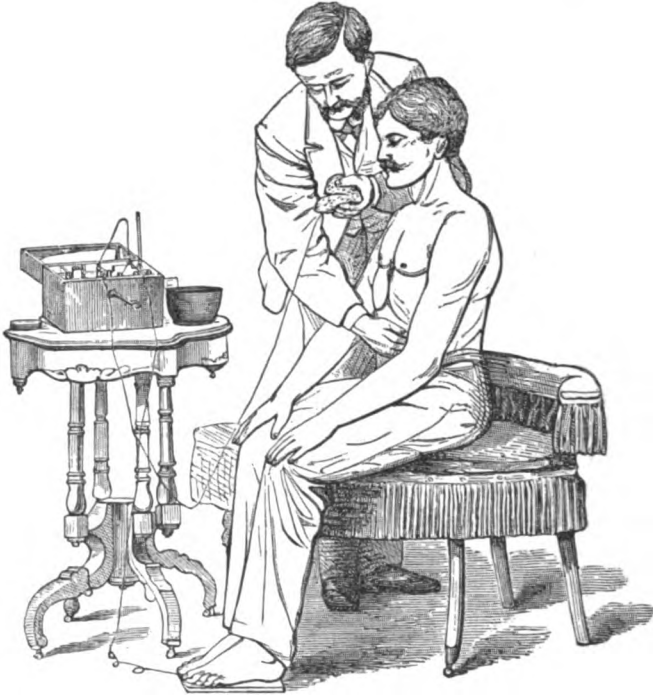

FIG. 94.

General Faradization—Application to the stomach.

*Applications to the Female Genitals.*—Direct applications to the vagina or uterus are rarely called for in general faradization.

*Applications to the Lower Extremities.*—Unless there is weakness or paralysis of the lower limbs we do not always apply the current directly to them, because, when the copper plate is at the feet, the muscles below the knee are more or less exercised during the whole treatment.

Before proceeding to make the applications to the lower extremities, the patient should be required to stand up, still keeping the feet on the copper plate. Male patients who, during the earlier stages of the operation, have entirely removed their clothing from the trunk, should

be allowed to again put it on, both in order to avoid unnecessary exposure and to protect them from the cold.

With female patients the applications to the lower limbs, except in cases of paralysis, can be made under the clothing, if the drawers be slipped down, without exposure.



FIG. 95.

**General Faradization.—Application to the Lower Extremities.**

The operator, sitting by the side of the patient, on a low stool or ottoman, should then pass the sponge or the hand lightly down the entire surface of both limbs, from the thighs to the feet, avoiding, so far as possible, the prominences of the bones at the hip, knee, and ankles.

The outer portion of the thigh, like the back, is very little sensitive to the electric current, because its surface is not supplied by very sen-

sitive nerves. The inner side of the thigh, on the contrary, is supplied by branches from the sensitive anterior crural nerve, and in nervous persons especially is very susceptible to electrization. In passing the sponge or the hand down the lower limbs great pains should be taken to carefully graduate the current according to the sensitiveness of each locality. This precaution is more necessary in treating the lower limbs than the upper, because the contrasts in the normal sensitiveness of the different parts of the lower limbs are much greater than in the arms, and because any severe shocks suddenly felt in the legs sometimes throw patients off their feet.

*In cases not complicated with paralysis, contractions of the superficial muscles of the lower limbs, as of the upper limbs, can be produced by comparatively feeble and painless currents.*

*Special Rules to be Observed in the Employment of General Faradization.*—In the employment of general faradization there are certain special suggestions, on the observance of which the results of the applications will very materially depend.

1. *The Strength of the Current and Length of the Application.*—It is better that the first tentative applications should always be made with a gentle current, and, if the patient be particularly sensitive, it is an advantage to use the hand of the operator instead of an artificial electrode. After the patient has become somewhat accustomed to the treatment, the general rule should be to make the applications *pleasantly painful*.

Patients who have long been accustomed to the treatment—who have become, in a certain sense, insensible to the strength of current ordinarily used—may frequently be benefited by very powerful currents.

Usually, but not invariably, we may be guided by the sensations of the patient; but exceptions to this rule are sometimes very striking, and should put us on our guard. Some who feel no pain during the applications may on the day following experience the most disagreeable reactive effects. (See p. 248.)

2. *Thoroughness of the Applications.*—General faradization does not require that all portions of the surface of the body should be touched by the electrode at every sitting. In nervous and susceptible patients we can approach the full measure of the treatment only by slow degrees. It is oftentimes sufficient to make the first application only around the neck, shoulders, and on the upper portion of the spine.

*It is not always necessary to make the applications to all portions of the surface of the body, even in a prolonged course of treatment. The general tonic effects of this system of treatment can undoubtedly be achieved without touching either the upper or lower extremities. But, on the*

*other hand, it is just as undoubtedly true that the muscular development that results from long-continued electrization of the arms and legs reacts favorably on the whole system and materially aids the treatment.*

The neck and spine should be treated in all cases, except during the first and tentative applications, or in patients of very unusual susceptibility. *During menstruation it is usually better to avoid the abdomen and lower part of the spine, or to suspend the treatment altogether, except in those cases where it is desired to increase the menstrual flow.*

*Length of the Applications.*—The duration of the sittings may range between five and twenty-five minutes, being modified by the nature of the constitution, the strength of the current employed, the stage of the treatment, and the results of the previous applications.

The smallest fraction of this time should be devoted to the head, the largest to the spine; next to the spine the abdomen should receive the largest share of attention.

1. An average application of say 15 minutes may be thus apportioned :

To the head.....	1	minute.
“ neck, sympathetic and cervical spine.....	4	minutes.
“ back.....	3	“
“ abdomen.....	3	“
“ upper and lower extremities.....	4	“

As compared with the time required in localized faradization and central galvanization, general faradization has not *the great disadvantage that has been supposed.* Nearly all the ordinary peripheral applications of electricity for paralysis require as much time as general faradization.

*Frequency of the Applications.*—The applications of general faradization may be repeated daily, every other day, once or twice a week, or by still longer intervals. Every other day is about as often as is necessary to secure the full tonic results of the treatment; but patients who are so situated that they can take the treatment but a short time may receive an application daily, provided they are not in a condition of unusual debility, or are not more than ordinarily susceptible to the current. For the very nervous and susceptible, and especially for those who complain of the secondary or reactive effects, it is often necessary to give intervals of several days, at least until the permanent tonic effects begin to be developed (see p. 220).

*Persistence in the Treatment.*—For the majority of cases, the treatment by general faradization, in order to secure its full results, must be *persistent.* The reasons why this perseverance is demanded are quite

obvious. In the *first* place, most of the diseases and morbid conditions for which general faradization is indicated are exceedingly chronic in their character. It is necessary ever to keep in mind the emphatic words of the great Trousseau, "Chronic diseases demand chronic treatment," whatever may be the method employed.

*Secondly*, Tonic remedies of all kinds, external and internal, are always more or less slow in their action.

While great and beneficial effects are often derived from two or three applications, a complete or approximate cure of long-standing morbid conditions, such as dyspepsia, hypochondriasis, nervous exhaustion, hysteria, paralysis, can only be achieved by persistent treatment, varying the strength of the current and frequency of the applications according to the progress which is made.

The length of time over which the treatment should be extended may range from one week to several months, with longer or shorter intervals, according to circumstances.

Comparing the history of all our cases, we find that the average number of applications administered to each successful case is about 15-25, and the length of time over which the treatment was extended 4-8 weeks.

*The Use of the moistened Hand as an Electrode to the Head and Sensitive Parts.*—The advantages which the moistened hand sometimes possesses over the sponge in general faradization are the following :

1. *In certain cases it is more agreeable to the patient.* It is but a truism to assert that no form of electrode that human skill shall ever devise can ever compare with the hand in flexibility and power of adaptation. Its shape, its flexibility, the number and arrangement of the fingers, and the vast and delicate combinations of movement of which they are so readily capable—all these familiar and wonderful characteristics of the hand, united to the peculiar softness of the skin, and the lightness with which it can touch, or press, or handle, render it superior for the nicer processes of general faradization to any artificial arrangements of which the genius of man could conceive.

For applications to the head and sides of the neck, the brachial plexus, and pit of the stomach, the use of the hand electrode is a very great convenience ; and we sometimes meet with patients who are so sensitive and so fearful that they will not endure even the softest sponge on any portion of the body, or at any stage of the treatment. To apply a mild faradic current to the forehead and crown of the head, with the softest sponge and largest possible surface, is at best an unpleasant process for a strong man in perfect health, and for the delicate invalid



is often unendurable ; but when the hand of the operator is made an electrode, the operation of faradizing the most sensitive portions of the head may be made not only tolerable, but positively agreeable. Except in cases of severe local disease or unusual debility, the sponge can be borne down the spine, over the abdomen and extremities, and down the lower extremities without great difficulty.

2. *It keeps the operator continually informed of the strength of the current, and thus enables him to carefully graduate it, according to the sensitiveness of each locality.*

As the current passes through his own person, the operator can judge by his own sensations whether it is too strong or too weak, and by increasing or diminishing the grasp of his other hand on the sponge, can modify the strength of the application without disturbing his apparatus. The wet sponge on which he presses with the other hand, acts, as we have seen, like a hydro-rheostat.

The use of the hand as an electrode enables the operator to instantly modify the applications in any of the various degrees of weakness and strength, and also to suspend the passage of the current instantaneously without shock or violence. When the sponge is used we must continually question the patient, or watch his expression and movements, in order to judge whether the current is of proper strength.

That most, if not all, of the tonic effects of general faradization can be obtained in perhaps the majority of patients by the use of the sponge, there can, we think, be no question ; but the use of the hand of the operator, according to the principles above indicated, enables us to achieve these results, and with less discomfort to the patient, in those peculiarly sensitive cases where the artificial electrode could not be borne at all. Very many of our patients we treat only with artificial electrodes.

*To sum up, in a word, it is a convenience and oftentimes a positive assistance for the operator to be able and willing to use his hand in applications to sensitive parts and nervous patients, but for the majority of cases it is sufficient to use a large soft sponge.*

*Effects of the Current on the Operator.*—The question now arises, What effect must the operator experience from the repeated passage of the electric currents through his own person ?

It should be understood, at the outset, that the current does not directly affect the *whole* person of the operator, nor indeed any of the prominent organs, and that only the faradic current is used in this way. The current passes from hand to hand, through the arms and shoulders, and does not reach or directly influence the brain or any of the organs

of the chest or of the abdomen. The effects of thus using the current on the nutrition of the muscles of the arm have already been considered (see Electro-Physiology, p. 194).

Those physicians whose temperaments do not tolerate electricity, would do well to avoid passing the current through their own persons in this way. Those, however, and they constitute the majority, who are more or less benefited by the use of electricity, in this way, need never fear any evil effects. If they treat a very large number of patients a day by general faradization, using the hand as an electrode a considerable portion of the time, and with strong currents, they will be much more wearied at night than if they used the sponge chiefly or exclusively. This method of general faradization has been and is now used by hundreds of physicians, and we have never heard of any serious effects in any instance. The few whose temperaments contra-indicate electricity soon abandon the use of the hand as an electrode, since they find that it is a luxury and not a necessity. The majority experience either negative or beneficial effects, and arrive at that state where it is a matter of indifference whether they use the hand or sponge.

*Special Effects of General Faradization.*—The general effects of electricity on the system have already been considered (p. 263). We have here to speak only of those that are peculiar to or most marked under general faradization.

The effects of general faradization may be subdivided into *three* classes:

1. Those which are experienced during or immediately after treatment.—*Primary or stimulating effects.*
2. Those which are experienced one or two days subsequent to the treatment.—*Secondary or reactive effects.*
3. Those which remain in the system as a permanent result of treatment.—*Permanent or tonic effects.*

Many patients, perhaps the majority, experience after each *séance* a feeling of *enlivenment and exhilaration* that often lasts for several hours. With some this feeling of exhilaration is very positive and decided; with others it is but just perceptible. Others, again, experience a disposition to sleep after treatment, quite similar to that which is felt after a bath in the surf.

*Relief of pain and local or general weariness* is a very frequent as well as very agreeable temporary effect of general faradization, and one which, more perhaps than any other, tends to inspire the doubting patient with confidence in the efficacy of this method of treat-

ment. Patients who suffer from indefinable nervous pains in the head, back, side, and stomach, or from weakness in the limbs, frequently appreciate relief even in the midst of the application. This relief usually lasts for several hours, and in some cases may become permanent.

All the disagreeable symptoms that sometimes arise from an application, as *headache, malaise, chilliness, vertigo, faintness, and cold perspiration* (see pp. 247-250), like similar effects from injudicious use of other tonics, physical exercise, the shower-bath, etc., are not usually of any permanency whatever. Indeed, they are entirely consistent with permanently good results; but they are apt to annoy and alarm the patient, and for that reason, if for no other, they should be avoided.

*Effect on Temperature.*—The *temperature* may be immediately influenced by general faradization.

Its effect on the circulation seems to be that of an *equalizer*. Patients afflicted with nervous diseases are apt to suffer from cold feet and hands, and from creeping chills over the body. The equalizing, warming effect of general faradization on such patients is most decided and agreeable, and is so positively realized, even in the midst of the *séance*, that neither the bare feet nor the exposed trunk suffer from the cold, provided the air of the operating-room is of even a moderate temperature.

*Effect on Pulse.*—The effects of general faradization on the pulse are quite interesting and suggestive.

In a large number of cases we have carefully counted the pulse, and also observed its quality just before and just after the treatment. The results of some of these observations are presented below:—

	Before the Application.	After the Application.		Before the Application.	After the Application.
1	60	60	12	68	80
2	77	76	13	104	100
3	88	80	14	68	80
4	74	80	15	70	73
5	60	75	16	106	102
6	82	84	17	72	60
7	80	76	18	72	67
8	76	84	19	74	70
9	80	84	20	68	76
10	101	90	21	72	66
11	115	100	22	74	62

On account of the recognized susceptibility of the pulse, especially of nervous invalids, to the influence of mental impression, we have found it necessary, in order to avoid error, to make repeated examinations before and after the sitting.

The conclusion, from our very large number of observations in regard to the influence of general faradization on the pulse in chronic diseases, is that of a corrective.

When the pulse is high it depresses it more or less, and usually in proportion to the degree of the exaltation above the normal standard. When it is low it raises it more or less, and usually in proportion to the degree of the depression below the normal standard. In nervous and excitable patients, the effect of general faradization on the pulse is much more marked than in the cold and phlegmatic. An application that is much too strong may greatly excite the pulse.

*Special and Exceptional Effects.*—The immediate effect on the appetite is, in rare instances, so marked that the patient at once feels desire for food, and at the next meal eats a much larger quantity and with far keener relish than usual.

Sensitive patients are now and then compelled to evacuate their bladder or rectum immediately after or even in the midst of the application, and the urinary secretion is occasionally increased. But all these effects of general faradization on the functions of special organs are incidental and occasional, and are not to be expected with any uniformity or constancy.

*Secondary or Reactive Effects.*—The *secondary or reactive* effects of general faradization are those which are experienced *for a day or two following an application*. These effects are probably not observed in more than half of the cases, and usually only at the outset of the treatment. Most of these secondary or reactive effects have already been considered (see p. 249).

*Soreness in the muscles* of the neck, trunk, and upper extremities is unquestionably the most frequent of the secondary symptoms of general faradization, and the one which patients are soonest to observe and describe. It is the result of the muscular contractions that are produced by the electric current. They usually pass off in two or three days, and are scarcely observed at all after the patient has once become accustomed to the treatment. By making the first tentative applications gentle and short, it is possible to avoid entirely this subsequent muscular soreness, and in very feeble or very timid patients we should always endeavor to do so.

Indefinable *nervousness* is another occasional secondary effect, and one that often gives rise to idle and unnecessary alarm. Like the soreness of the muscles, it usually passes off in a day or two, and is not commonly experienced after the patient has become accustomed to the treatment.

*Weariness and exhaustion* may be experienced by this class of pa-

tients for several days after an injudicious application. It is a very interesting and important fact, that these annoying *secondary* symptoms of weariness and exhaustion are oftentimes experienced to their fullest extent by patients on whom the *immediate effects* for a few hours succeeding the application are only agreeable. On account of this fact, the inexperienced electro-therapeutist may be unpleasantly deceived, and from the temporary enlivenment of his patient may suppose that his application has been thoroughly successful, until the distressing secondary effects, continuing perhaps for several days, show most clearly that it has been either too strong or too protracted.

*Permanent or Tonic Effects.*—To designate any precise time or stage of the treatment when these tonic effects are to be looked for, is manifestly impossible. Like the tonic effects of other analogous internal or external remedies, the time of their appearance must be variously modified by the nature of the disease, the constitution of the patient, and the skill and perseverance of the treatment. They may appear early in the treatment, developing themselves with great rapidity; or they may remain latent until after the applications are abandoned, and then advance with sure and steady progress. They may be so rapidly manifested at the commencement of the treatment as to cause us to suspect them to be more the result of mental impression than of the applications; and, on the other hand, they may develop themselves so long after the treatment as to suggest the doubt whether they are not as much due to nature and time as to the direct electric influence.

Among these tonic effects of general faradization, those which chiefly attract the attention and are of the principal importance are the following:

*Improvement in the Sleep.*—This symptom comes *first* in our analysis of the permanent effects of general faradization, because it is one of the first to be appreciated and observed by the patient. As insomnia is the most constant and universal symptom of those various nervous conditions for which general faradization is indicated, just so is its relief or cure the first and leading evidence that the treatment is having its desired effect. As already mentioned, inclination to sleep is one of the *immediate* symptoms of the applications and may come on even in the midst of the séance; but the improvement in the sleep of which we here speak, as a *permanent* effect, is appreciated during the intervals of treatment, and long after it has been suspended.

*Increase of Appetite and Improvement in Digestion.*—Increase of appetite and improvement in the digestion is not so early nor as constant a symptom as improvement in the sleep.

It is by no means a constant or uniform effect, even in those cases where it would seem to be needed, and where, too, in all other respects, great and lasting benefit is derived from the treatment. Some patients who are permanently relieved of neuralgia, of insomnia, and of muscular and nervous debility, yet observe no decided improvement in their digestion. Such cases, however, are quite exceptional.

*Regulation of the Bowels.*—Constipation sometimes yields very early in the treatment. The temporary effect is probably due, in many instances certainly, to the direct mechanical action of the current on the intestines; but permanent relief, either of constipation or of diarrhœa of the nervous variety, is not to be expected until the indigestion and general debility on which they depend have first been corrected.

*Improvement in the Circulation.*—Permanent equalization of the circulation is most observed in cases of dyspepsia, nervous exhaustion, hysteria, and similar conditions with which defective circulation is so frequently associated. It is then the result of the improvement in the assimilative power and nutrition of the system.

*Relief of Nervousness and Mental Depression.*—The indefinite, though very well recognized condition which we term nervousness, and the indefinable mental agony that forms so prominent and so distressing a symptom in hysteria, dyspepsia, exhaustion, and other nervous conditions, sometimes yield to general faradization quite early in the treatment.

*Increase in the Size and Hardness of the Muscles, and in the Weight of the Body.*—This is a natural result and accompaniment of the improvement in nutrition, and that it follows the use of the faradic as well as of the galvanic current, sufficiently demonstrates that power over nutrition is not confined to the latter.

Under the influence of protracted treatment by general faradization, the muscles are sometimes developed in size as well as in firmness to a degree which very naturally astonishes those who, for the first time, have their attention directed to it. This increase in size and quality of the muscles is, of course, chiefly observed in those portions of the surface of the body where, under the influence of faradization, contractions are most easily produced. Therefore we first look for this effect in the arms, the legs, and afterwards in the chest. This effect is soonest observed in patients who are comparatively thin, or at least, whose muscular tissue predominates over the adipose. On the other hand, and for obvious reasons, it is not so perceptible in females, or in the very corpulent of either sex.

Under general faradization *actual increase in the size and weight of*

*the body* sometimes takes place so rapidly and perceptibly to the eye that it need not be confirmed by reference to the scales. In other cases, where patients, either through curiosity or accident, have carefully weighed themselves just before taking a course of treatment, a most remarkable increase of weight has often been observed in the course even of a few weeks.

The increase of weight is simply a result of the effect of the electric currents on nutrition, and a natural sequence of the improvement in the sleep, the increase of appetite, and the relief of pain and mental depression of which we have already spoken.

*Increased Disposition and Capacity for Labor of the Muscles and of the Brain.*—Whatever tends, directly or indirectly, to improve nutrition must of necessity increase the capacity for intellectual and muscular toil. Accordingly we find that patients who were so feeble that even a short walk or ride was fatiguing, and who were signally deficient both in the will and the capacity for exertion, soon begin to develop, under treatment, an activity and vigor that is sometimes surprising. They can walk farther and more vigorously, and with greater enjoyment. They realize a consciousness of strength to which before they were strangers, and feel emboldened to exertion from which they would formerly have shrunk with apprehension.

Concerning these permanent tonic effects it is to be observed :—

1. *They are not uniform.* They vary not only with different individuals and diseases, but also with the same individual at different periods of life.

2. *They are more rapidly appreciated by the active and the nervous than by the cold and phlegmatic.* Other conditions being the same, a sensitive, impressible organization will recover more rapidly under general faradization than one of an opposite temperament.

3. *They are frequently not experienced until long after the treatment is abandoned.* These *after effects* of general faradization are worthy of the highest attention. The possibility that they may occur is a constant encouragement in the treatment of all slow and obstinate cases.

4. *They are usually as lasting and permanent as similar effects from other remedies and systems of treatment.* It is true that patients who have been apparently cured by general faradization are subject to relapses, yet to no greater and apparently to a less extent than those who have derived similar relief from internal medication. In considering this statement, regard should be had to the fact that the diseases for which general faradization is chiefly indicated, at least those in which it

has thus far been most successful, are just the diseases which are most likely to relapse under any or all forms of treatment.

*Rationale of the Effects of General Faradization.*—It has been said of general faradization that it is not physiological; but they who raise this objection do not well consider what they say. Of the various methods of electrization none can be better explained on a physiological basis than can this. General faradization is to the whole body what localized faradization is to an individual part or organ. All the physical, mechanical, chemical and physiological effects, with the consequent increase of the processes of waste and repair and improvement in nutrition that electrization is capable of producing in the living tissues (see *Electro-Physiology*, p. 177) and which, in exclusively localized applications, are mainly confined to the part which is traversed by the current, are in general applications appreciated by every part of the system. Then, again, the improvement which each part or organ receives from the treatment reacts upon every other part and organ. Every effect becomes in its turn a cause; the strengthened brain sends more nervous force to the stomach, by which the latter is enabled to send better blood to the brain.

Comparing what is known of the conductivity of the tissues (see p. 180), and the action of the electric currents upon them, with the observed effects of general faradization, these effects may be regarded as due mainly—

1. *To the fact that the nutrition of the entire central nervous system is directly influenced by the current.* In an ordinary application the brain, spinal cord, and sympathetic ganglia are all subjected to the action of the current. In most of the applications of central localized electrization only a part of the central nervous system is affected at each sitting. We are warranted in believing that in nearly all nervous diseases the central nervous system is more or less disturbed, even when it is not organically diseased.

2. *The passive exercise that results from the vigorous and repeated muscular contractions produced by the applications.* When the applications are thoroughly and skilfully made, vigorous yet agreeable contractions are excited, not only in all the superficial muscles, but in the deeper layers, and also of the contractile fibre-cells of the stomach, the intestines, and other vital organs. The augmentation of the manifold processes of waste and repair which a single sitting causes in the muscles and abdominal organs would alone powerfully influence nutrition, even though the electric current exerted no direct effect on the nervous system.



That the tonic effects of general faradization are very largely due to the passive exercise which it produces, is proved clinically by the fact that when a current too feeble to cause muscular contractions is used, or when the muscles are neglected, the tonic as well as the primary effects of the treatment are much less marked.

3. *Reflex action from the sensory nerves.* The reflex effect of the faradic current even is very powerful, and in general faradization nearly all the superficial sensory nerves are acted upon, and consequently the whole nervous system is constantly under reflex as well as direct influence of the current.\*

\* Brown-Séquard and Lombard (*Archives de Physiol.*, November and December, 1869) have shown that when one arm is pinched the temperature of that arm slightly rises, and that of the opposite arm falls. Dr. James J. Putnam (*Boston Medical and Surgical Journal*, June 23, 1870) has shown by a series of experiments on frogs that electrization of one foot caused reflex contractions of the blood-vessels in the web of the foot of the opposite side. These experiments, taken in connection with the fact that nutrition is closely related to circulation, would render it clearly probable that reflex action is an important factor of the results of application of electricity, and especially of general faradization, where the extremities are directly affected by the current.

## CHAPTER XI.

### DIFFERENTIAL INDICATIONS FOR THE USE OF LOCALIZED AND GENERAL FARADIZATION.

IN order to determine the differential indications for the use of localized and general faradization we need to consider these four facts :

*First*, That general faradization *directly* affects the whole body, while in localized faradization the direct action of the current is mainly confined to the part to which the application is made.

*Secondly*, That general faradization may, by sympathetic or reflex action, *indirectly* have a special therapeutic influence on some *special* part or organ, while localized faradization of any part, but especially of the sympathetic or cerebro-spinal axis, by sympathetic or reflex action, may *indirectly* have a *general* therapeutic influence on the whole body.

*Thirdly*, Faradization, when properly performed, very rarely injures, and usually more or less benefits, even those parts which are in comparative or absolute health. This consideration has an important practical bearing, especially in the use of general faradization, in cases of doubt as to the seat of the disease. (See p. 234.)

*Fourthly*, In nearly all cases it is important, and in many it is indispensable, that the applications should be made to the seat of the disease as well as to the locality of the symptom. Scientific electro-therapeutics, therefore, requires the most accurate preliminary diagnosis; above all, it is important to rigidly discriminate between diseases which are of a constitutional and those which are of a local origin.

From these fundamental considerations we logically derive the general law that *constitutional diseases are better treated by general, and local diseases by localized, faradization.*

More specifically, experience demonstrates that of the large variety of diseases for which applications of electricity are found useful, localized faradization and galvanization are specially indicated in those cases where both the seat and the effects of the disease are restricted to cer-

tain portions of the organism, with but slight or imperceptible influence on the system at large. Under this head are included nearly all peripheral and reflex paralysees and neuralgias, effusions, sprains, and local injuries, and also many of the diseases of the eye, ear, larynx, and genital and digestive organs.

On the other hand, general faradization is indicated—

1. In those diseases that are dependent on or associated with impairment of nutrition and general debility of the vital functions, such as nervous dyspepsia, neurasthenia, anæmia, hysteria, hypochondriasis, paralysis, and neuralgia of a constitutional origin, rheumatism and other toxic diseases, some forms of chorea, and oftentimes in functional disorders of the genital, digestive, and other special organs.

2. In morbid symptoms dependent on some local cause which cannot be satisfactorily diagnosed. It must be confessed that a large number of cases of chronic diseases are frequently dependent on or connected with some important lesions, of which, during the lifetime of the patient, even the most approved methods of diagnosis and the most practised skill utterly fail to ascertain either the nature or the locality. This is oftentimes the case with epilepsy, hysteria, and hypochondriasis; sometimes, also, with affections of special organs, as the eye, ear, larynx, and uterus.

Benedikt emphatically affirms that electricity should be applied almost exclusively *in loco morbi*, in the place of the disease, and in cases of doubt recommends tentative applications successively in all the suspected localities until the diagnosis is made out by the success of the treatment.\* It scarcely need be said that this purely experimental system, though sometimes successful, must be and is annoying, uncertain, and very frequently unsatisfactory.

The advantage of general faradization in such cases of doubtful pathology are twofold: *First*, at each application it affects all parts of the body, and thus is sure to reach the seat of the disease, wherever that may be; and, *secondly*, it at the same time improves the general nutrition of the system, which, in such cases, is frequently more or less impaired. This improvement in nutrition, as has been stated, oftentimes reacts favorably on the local disease.

Still further, it must be confessed that very many of the diseases in which general faradization is proved to be of most efficient service, are those in which no special *locus morbi* can be found even on *post mortem* examination.

\* Die Electrotherapie. Wien, 1868, p. 79.

### 374 GENERAL AND LOCALIZED FARADIZATION COMPARED.

Future investigations will undoubtedly do much to dispel our ignorance on these points, and will probably assign a definite local cause to some of the diseases which are now vaguely classed as constitutional. But even those diseases in which the local cause is definitely ascertained may demand constitutional treatment as much as or more than those in which no local cause is demonstrated. When a house is set on fire by a burning fuse, it is not enough to snatch away the fuse; we must extinguish the flames. When the nervous system has been thrown into tetanus by a wound in the foot, excision or healing of the wound is of little avail; remedies must be directed to the central nervous system. Precisely so when chronic local disease has enfeebled the vital functions and impaired nutrition, our applications are to be directed to the general system as well as to the seat of the lesion.

3. In certain diseases which, though themselves incurable, are accompanied by impairment of nutrition that is susceptible of more or less relief. Palsy agitans, many cases of cerebral and spinal paralysis, advanced stages of locomotor ataxia, rheumatic gout, epilepsy, and certain spastic affections, may be absolutely incurable, and yet the emaciation, nervousness, insomnia, and general feebleness with which these diseases are associated as cause or effect or concomitant, may be susceptible of most grateful relief from general faradization. In not a few cases of disease of these varieties, after we have failed to do any good by galvanization of the brain, sympathetic and spinal cord, after even central galvanization has failed, general faradization alone, given without special reference to the seat of the pathological lesion, has greatly relieved the symptoms and been of invaluable service by virtue of its tonic effects, although, of course, it could have no permanently curative influence.

Illustrative cases of every grade will hereafter be presented in detail.

*Cause of Failures in Electro-Therapeutics.*—The comparison we have here made reveals the cause of some of the failures and discouragements that have been and are now being encountered by many experimenters in the department of electro-therapeutics. *Constitutional diseases have been treated locally.* Morbid constitutional conditions, such as hysteria, anæmia, rheumatism, and the like, which, as all physicians agree, demand remedies that affect the system, are treated electrically only through their local symptoms, such as peripheral paralysis, or neuralgia, or inflammation of the joints. Temporary relief, or metastasis of these local symptoms may indeed result from exclusively localized applications in such cases, but permanent correction of the morbid condition on which these symptoms

depend can only be obtained by general treatment. In subacute rheumatism, for example, galvanization or faradization of an inflamed joint frequently removes the pain and effusion in that joint, and therefore may advantageously be used with general faradization, just as the external application of alkaline solutions may advantageously be combined with the internal administration of the same remedies; but to depend on merely localized electrization in such cases is manifestly as unphilosophical as it would be to depend on merely local applications of alkalis. In general practice it will unfortunately be found that physicians will frequently use localized in cases for which general treatment is indispensable for complete results, for the reason that they have neither the time nor the practice to enable them to use the latter method with success; just as the majority of general practitioners, for want of a galvanic apparatus, are obliged to use faradization in cases for which galvanization is imperatively demanded.

*Combination of the Methods.*—Many cases are most successfully treated by a combination or alternation of the two methods. Thus rheumatism, for example, may be treated one week or one day by general faradization, and the following day or week by local faradization or galvanization of the affected joints.

This comparison furthermore reveals and explains the suggestive fact that the sphere of electro-therapeutics has, in a measure, corresponded to and progressed with the advance in the method of application. Thus, when peripheral applications were chiefly used, the scope of electro-therapeutics, though important, was narrow, neuralgia and paralysis being the diseases for which it was mainly employed. On the introduction of localized galvanization of the nerve-centres, electricity was found to be most useful for many conditions in which previously it had been supposed to be either valueless or contraindicated. The sphere of electro-therapeutics is by general faradization and central galvanization still further extended to embrace a large variety of conditions and indications which localized applications fulfil either not at all, or but very imperfectly.

## CHAPTER XII.

### CENTRAL GALVANIZATION.

*The object in central galvanization is to bring the whole central nervous system—the brain, sympathetic and spinal cord—as well as the pneumogastric and depressor nerves, under the influence of the galvanic current. One pole (usually the negative) is placed at the epigastrium, while the other is passed over the forehead and top of the head, by the inner borders of the sterno-cleido-mastoid muscles, from the mastoid fossa to the sternum, at the nape of the neck, and down the entire length of the spine.*

The following representations of the principal steps in the method of central galvanization were made from photographs taken during the applications.



FIG. 96.

CENTRAL GALVANIZATION, first stage. One pole on the epigastrium, the other on the cranial centre, the hair at that point being moistened. Before making the application at this point the electrode may be passed over the forehead.

A female patient is taken in order to show that this method in its entirety requires little or no exposure.



FIG. 97.

CENTRAL GALVANIZATION, second stage. One pole same position as before, or lower down, and the other passed up and down by the inner border of the sternocleido-mastoid muscle from the auriculo-maxillary fossa to the sternum.

*Details of the Applications.*—We do not always make the applications all over the head, but merely on the forehead, gently passing the electrode from one side to the other; then baptize the patient on the *cranial centre*, at the top of the head, and rest the pole there for about one minute, and sometimes longer. To the head we apply from two to six or eight cells—for patients vary in their susceptibility—beginning with a weak current, and gradually increasing until a sour or *metallic taste* is perceived in the mouth. The *cranial centre*—the summit between the ears—we regard as the most important region of the head in all electrical applications, and especially in central galvanization. A current passing from that point to the epigastrium, traverses the centre of life—if life has any centre—and affects the sympathetic, and the roots of the facial nerves. The sensation produced by this application is different from that of any other application to the head, and is sometimes indefinable.

An application to this point for one or two minutes is usually about as much galvanization as the brain needs. In exceptional cases, where the hair is thin, or the head is bald, we make the applications all over the surface, back and front. In applications to the head, care should be taken to avoid sudden interruptions, or shocks that cause dizziness; the flashes of light before the eyes are of little account, but nothing is gained by producing them, and they are annoying to the patient.



FIG. 98.

CENTRAL GALVANIZATION, third stage. One pole same position as before, or on the breastbone, and the other at the back of the neck between the first and seventh cervical vertebræ.

The electrode is then passed down the inner border of the sterno-cleido-mastoid muscle, from the auriculo-maxillary fossa to the clavicle, for the purpose of affecting the pneumogastric and sympathetic. We usually make the application on both sides, and from one to five minutes.

In galvanizing the spine, especial attention is given to the *cilio-spinal* centre, below the first and seventh cervical vertebræ, which is to the spine what the cervical centre is to the brain. The cervical sympathetic



and pneumogastric, as well as the spinal cord, are affected by the current. The electrode should also be passed over the entire length of the cord by *labile* applications up and down. The back is not usually sensitive, and strong currents, from ten to thirty cells, can be borne without any more discomfort than a burning or pricking sensation beneath both electrodes.



FIG. 99.

CENTRAL GALVANIZATION, fourth stage. One pole same position as before, or over the abdomen, and the other passed beneath the loosened clothing, up and down the cord, from the seventh cervical vertebra to the coccyx.

The back may be treated from three to six minutes, and the whole length of the *séance* of central galvanization ranges from five to fifteen minutes.

*Preparation of the Patient.*—All the preparation a *male* patient requires for central galvanization is to unbutton and loosen the collar, remove the coat and vest, and slip up the whole clothing, so that free access can be had to the spine.

A *female* patient may remove her corsets and slip up her under

clothing, or merely loosen the clothing at the neck and waist, so as to make room for an electrode to be passed down to the epigastrium, and for a spinal electrode to be passed up and down the back.

*Electrodes.*—For the negative electrode at the pit of the stomach, any sponge or flannel electrode with a broad surface, so as not to be too painful, and an insulated handle that the patient can hold, will answer.

For the positive pole, we prefer *adjustable* electrodes (see p. 323), of different sizes. These can be passed under the clothing with great ease, and can also be provided with flannel covers, that may be washed as often as necessary.

*Battery.*—Almost any form of galvanic battery will answer for central galvanization, but for reasons before given (p. 311), a battery that gives a steady uniform current, and that is provided with a rheostat, is preferable. The Cabinet battery is exceedingly convenient for central galvanization.

The method of central galvanization is based on these four assumptions, all of which seem to us justifiable.

1. That in a very large number of diseases, and especially of the so-called functional diseases, the pathology is not exclusively confined to any region of the brain, or sympathetic, or spinal cord, but the whole central nervous system is invaded by a condition of exhaustion and irritability. We believe this to be true not only of hysteria, chorea, and of many affections allied to them, but of certain states of neuralgia, and a number of diseases of the skin. It is possible, furthermore, that some diseases that are not now regarded as in any respect of a nervous character may in the future be shown to depend so closely on the nervous system that they can be most successfully treated, not through their varying and local manifestations, but through the brain, spinal cord, and sympathetic. That certain diseases, not primarily nervous, do so affect the nervous system that they need to be treated, in part at least, by remedies that act on the nerves, will be conceded, I suppose, without question.

2. That a large proportion of the most frequent and distressing chronic diseases, as hysteria, hypochondria, neurasthenia, chorea, epilepsy, nervous dyspepsia, neuralgia, and many forms of insanity, are so obscure and subtle in their pathology that it is impossible to determine the precise seat of the disease in any given case, even where some local pathological condition may exist, and consequently we can never know just where the current should be localized. Even when the seat of the disease is, or is supposed to be, accurately known, if a special revelation

should kindly inform us whether epilepsy, for example, takes its origin in the brain or in the sympathetic, and should point out to us just where the lesion occurred, we should still be in the dark in regard to the best method of localizing the current, for without another and still more complex revelation we could not determine the extent to which all other parts of the nervous system had been affected by the local disease.

The force of this objection to the use of the accepted method of galvanizing the brain and cervical sympathetic is seen when we attempt to give the complete pathology of any of the diseases we have just mentioned, and, indeed, of almost any nervous disease that can be mentioned. Where is the precise seat of the disease in nervous dyspepsia? We know that the stomach is weak, and we prescribe galvanization of the pneumogastric; but what have the solar plexus and the spinal cord to say in the matter? Who can tell just how not only they, but the brain itself, may be the origin of nervous dyspepsia, or how much they share in the pathological disturbance, and consequently how much they need treatment? After eleven centuries of medical study, who can tell the precise and exclusive seat of the disease in epilepsy, hysteria, and neurasthenia? Is not the probability continually growing stronger with the advance of science, that in these and many other diseases the whole or a large part of the central nervous system shares as a cause, or result, or concomitant? Even in those diseases where the lesion is understood, is there not much more of the unknown than of the known? In locomotor ataxia, progressive muscular atrophy, spinal congestion and irritation, is the spine only at fault? Do the sympathetic and brain wholly escape the infection? "Evil communications corrupt good manners" in pathology as well as in morals, and the communications between the sympathetic, and cord, and brain, and the nerves that branch from all these, are so varied, and intimate, and complex, that when the cord is known to be diseased we very naturally incline to consider the other parts of the nervous system, like "poor dog Tray," in bad company, and we become very justly suspicious of their character. In this suspicion we are justified by the accepted views of the functions of the sympathetic, and by the clinical signs and symptoms of these diseases.

In cerebral hemorrhage we usually know the general locality of the disease, if not its precise nature; but the spinal cord, through disuse, becomes affected with secondary degenerations, and the organs of digestion also more or less sympathize.

3. That the nutrition of the central nervous system will be improved by passing through it a mild galvanic current.

That in the great majority of cases of so-called functional nervous disease, and in many of the cases of special structural lesions, nerve-tonics are indicated, will be questioned by no one. It is also coming to be pretty generally admitted that electricity is something more than a stimulant—that it is a *tonic* with a powerful *sedative* influence. Still further, it is admitted that the sedative and tonic effects of electricity can be obtained by passing the current, with little or no interruption, through any part, the nutrition of which needs to be improved.

4. It is impossible to *exclusively* localize the current in the cervical sympathetic, hence it is certain that the good results that in some instances follow the galvanization through the neck are due to the effect of the current on the spinal cord or pneumogastric, as well as to the cervical ganglia of the sympathetic. That the beneficial effects of galvanizing the neck in cases of nausea, dyspepsia, and gastralgia, are due in part if not entirely to the effect of the current on the pneumogastric, is more than probable. Conversely, we find it impossible to tell how far our attempts to localize the current in the pneumogastric, by placing one pole at the pit of the stomach and the other by the inner border of the sterno-cleido-mastoid muscle, was successful; and whether the benefit derived took place through the pneumogastric, the sympathetic alone, or through both combined, seems beyond the power of mortal skill to determine.

Similar difficulties are experienced in the attempt to differentiate the effects of the galvanizing the brain; how much the results of applications to the head are due to the direct or reflex action of the current on the brain itself, how much to its action on the cephalic ganglia of the sympathetic, and how much to its action on the roots of the pneumogastric and the upper part of the spinal cord, seems in the present state of the sciences of anatomy and physiology absolutely impossible to determine. In galvanizing the spine we are puzzled by the same complications. The cervical, thoracic, and abdominal ganglia of the sympathetic, with their enormous plexuses, are all liable to be affected by the current whenever it is applied up and down the spine; and how far the beneficial results of galvanization are due to the effect of the current on the cord itself, and how far to its effect on these ganglia and plexuses, only a special revelation can determine.

Still further, the subject is complicated by the consideration that electricity works powerfully by reflex action, and in galvanizing the brain, the cervical sympathetic, or the spine, reflex action must continually take place through the nerve-centres, and the therapeutical results produced by such treatment must be in part attributable to such reflex action.

The positive pole (anode) is applied over the head, neck, and spine, because it is less irritating than the negative, and tends to diminish irritability. The majority of the cases for which central galvanization is used are in a condition of abnormal irritability, and need the calming effects of analectrotonos rather than the irritating effects of catalectrotonos. To this rule there are individual exceptions: there are cases that appear to be benefited more by the negative than the positive pole. (See pp. 226-228.).

The negative pole (cathode) is placed at the epigastrium, because the epigastrium is a good, indifferent point, that will bear well the irritating effect of catalectrotonos. In order to avoid over-irritating the stomach and the pneumogastric nerve, it is well, in very sensitive patients, and when long applications are used, to change the position of the negative electrode by moving it up and down between the sternum and abdomen.

The positive and negative modifications (see *Electro-Physiology*, p. 103) that take place at the breaking of the galvanic current, in the region of the anode and the cathode, probably complicate somewhat the effects of treatment—are, indeed, factors of some importance in producing the effects, and not unlikely explain, in part, the disagreeable results that come from too frequently interrupting the current when treating nerve-centres. The positive and negative modifications can, however, be mostly avoided by using a rheostat of some kind, and gradually reducing the strength of the current to a minimum before the electrodes are removed.

*Central Galvanization Compared with Localized Galvanization of the Nerve-centres.*—We claim for central galvanization a distinct and separate position among the different methods of using electricity in medicine. The applications of the galvanic current to the head, the neck, and the spine, which have been variously used by electro-therapeutists since the time of Remak, are simply forms of localized electrization, since the object aimed at in all of them is to localize the current, so far as possible, in the brain or some portion of it, in the cervical ganglia of the sympathetic, or in the spinal cord. Then, again, in all these forms of localized galvanization of the nerve-centres, the poles are placed near each other over the part to be affected, and the peculiar action of both poles is felt, so far as is possible by external application, in the organ that is treated.

In galvanizing the head, for example, the poles are applied behind the ears, or in front of them, or one is placed on the forehead, and the other on the occiput, or at the nape of the neck. In galvanizing the cervical ganglia of the sympathetic, one pole is placed on the

auriculo-maxillary fossa, or along the inner border of the sterno-cleido-mastoid muscle, while the other is applied at the back of the neck. In galvanizing the spine, one pole is placed at the upper or lower part, while the other is passed up and down the entire length, or kept in one place, or both may be moved up and down the entire length of the cord, or confined to any portion, as is desired.

But in central galvanization the electrodes are so placed that the whole central nervous system is brought under the influence of one pole (usually the positive) of the galvanic current at one sitting, and without any important change of position of the negative pole. Besides the central nervous system, the pneumogastric and the stomach itself are also affected; in a word, the great centres of life, of health, and of disease.

Comparing central galvanization with localized galvanization of the nerve centres, by the *effects*, we find differences of a most marked and interesting character exist. The ordinary methods of galvanizing the cervical sympathetic, the brain, or the spine, do not, either singly or in combination, produce the powerful tonic results that are frequently obtained by central galvanization. Sedative and tonic effects are unquestionably produced by these local methods, but they are frequently inferior in quality and degree to those derived from central galvanization when properly administered. This conclusion is derived from actual trial and observation of cases. Neither the temporary nor the permanent effects of localized galvanization of the brain, of the cervical sympathetic and pneumogastric, or of the spine, are as satisfactory in many cases, even when they are successively used at the same sitting and with the same time and strength of current, as central galvanization.

Still further, experience teaches that the method of central galvanization, in its completeness, is more serviceable than partial or incomplete applications of it. Placing the negative pole on the epigastrium, and the other on the spine, will not accomplish the full effects of central galvanization, although so far as it goes it is a good method, and produces sedative and tonic effects. To confine the attention to the head and neck alone, also, is not sufficient.

*Compared with General Faradization.*—Comparing central galvanization with general faradization, we find most important differences. In the one only the galvanic, in the other only the faradic, current is used.

In general faradization the application is made not only over the central nervous system, but over the entire trunk, and especial attention is given to the muscles of the abdomen and extremities. In central galvanization the chief aim is to affect the central *nervous* system; in

general faradization the chief aim is to affect the *muscular* system, although the nervous system, central and peripheral, is affected both directly and reflexly.

Comparing the effects of central galvanization with those of general faradization, we find that both are powerful tonics, and are adapted for conditions of debility, by whatever names they may be known. For some cases, and particularly for cases associated with great *muscular* debility, general faradization is more effective than central galvanization. On the other hand, in cases where simply *exhaustion* of the nerve-centres is the leading condition—as hysteria, chorea, and so forth—central galvanization is oftentimes far superior to general faradization.

*Central Galvanization alternated with General Faradization.*—Some of the best results that we have yet seen have been secured by combining or by alternating the two methods.

Sometimes, after general faradization has done all that it is capable of, central galvanization, rightly used, helps to lift the patient still higher. In cases where we are not experimenting, and seek only the best good of the patient in the shortest time possible, we use in succession, or alternation, and with changes and modifications, all the principal methods—local galvanization of the brain, of the cervical sympathetic and spine, general faradization and central galvanization. This course is found to be oftentimes justified by the results. The improvement is more positive and more permanent than when a single method is used exclusively.

Some cases we treat one week by general faradization, the next week by central galvanization; sometimes we alternate the methods from day to day.

There are, however, cases not a few, where all forms of faradization, and where local galvanization of the nerve-centres irritates rather than benefits, but in which, under the method of central galvanization, there is sure and constant improvement.

Dr. Althaus, of London, in the third edition of his most excellent work on Medical Electricity, after describing this method of central galvanization in detail, remarks that he had never carried out the method in its entirety, but that he had used, experimentally, applications to the head and neck with the anode, and to the epigastrium with the cathode. He states that unpleasant results have followed these experiments, that disagreeable cerebral symptoms were produced by it during the application, and which sometimes continued for twenty-four hours or more afterwards.

“The patients had a general sensation of *malaise* and nervousness, headache, and a feeling of giddiness and confusion.”

Dr. Althaus further states that he has used the “application of the anode to the cervical and lumbar spine, and of the cathode to the pit of the stomach with advantage.”

Nothing is easier than to produce these unpleasant results in susceptible patients by any method of galvanizing the brain and neck, provided strong currents are used, or interruptions are allowed, or the applications are prolonged. The same effects may follow general faradization and localized galvanization.

In beginning to treat a patient by central galvanization, we should use very mild, scarcely perceptible currents, particularly around the head and neck, and even on the cervical spine, and great pains should be taken to avoid breaking the current, and the application should be of only a few moments' duration. Taking these precautions has now become with us a mere matter of routine, and we are every day accustomed to treat the most sensitive and delicate patients—cases of hysteria, nervous exhaustion, hypochondriasis, and allied affections—cases which are sufficiently familiar to all American physicians, and with sedative and tonic effects that are not obtainable by other methods.

Whenever any of the disagreeable effects spoken of by Dr. Althaus occur, we always give the patient a longer interval, and moderate the applications until only good, unmixed with evil, effects appear.

The American constitution is more susceptible to electricity than the English or the German, and if our nervously exhausted, hysterical women can bear and be profited by central galvanization, surely the women of England and Germany might be treated by the same method, even when used with less caution.

We have frequently treated by this method delicate women who are too feeble to walk or stand, or even to sit up, and who, therefore, must be treated in bed, and even in such cases, the disagreeable effects only occur now and then, and no oftener than they occur when other methods of electrization are employed in the same kind of cases; indeed, not so frequently as they follow general faradization or local galvanization of the brain.

*Reply to Objections against Galvanization of the Nerve-centres.*—It is proper here to consider briefly some of the objections that have been brought against galvanizing the nerve-centres by the method of central galvanization, or by any form of local galvanization. These objections, which in some instances have come from persons who on other subjects are well-informed, are of a threefold character.



1. That the current goes around the nerve-centres, and not through them. This objection is fully met by the experiments recorded in *Electro-Physiology*, pp. 173-176.

2. That we do not completely understand what the current does when it penetrates the nerve-centres—in other words, the rationale of the effect of electricity on nutrition is not yet an exact science. This objection is just enough, considered as a fact, but considered as an argument, it attempts to prove too much. By referring to *Electro-Physiology* we shall see that there are few, if any remedies, the action of which is as well understood as electricity. We do not exactly and exhaustively know its action on the nerve-centres, neither do we exactly and exhaustively know its action on the peripheral muscles and nerves, and if this objection is to hold good against galvanization of the nerve-centres, it must also hold good against all peripheral galvanization and faradization.

3. That it is dangerous to apply the galvanic current through the head and neck.

Dr. Anstie, who is a very strong friend of electro-therapeutics in general, in his excellent work on neuralgia, speaks of galvanization of the cervical sympathetic as a method to be either avoided or used with very great caution, and, in support of this view, adduces a case in his own practice. In a review of Tibbetts's little "Hand-book of Medical Electricity," Dr. Anstie repeats this caution, and expresses apprehension lest great injury may follow the use of this method of treatment. The error of Dr. Anstie consists, not in enjoining caution, since this is needed in all electrical applications, but in suggesting the idea that galvanization of the cervical sympathetic is a dangerous procedure, likely to produce serious results. Quite recently Dr. Brown-Séguard, in a foot-note to one of his series of very able papers, speaks as follows:

"Recently, some bold physicians have tried to galvanize the cervical sympathetic nerve. This I did once in 1855 on my eminent friend Prof. Ch. Rouget, to try to relieve him from a most violent headache.

"The effect was all we could desire against the headache; but the galvanic current, acting at the same time on the sympathetic and the vagus (the simultaneous excitation of these two nerves cannot be avoided), produced such a dangerous syncope, that I promised myself that I would never try again to apply galvanism to the cervical sympathetic of man."\*

The best reply to objections of this nature, coming from men who

\* *Archives of Scientific and Practical Medicine*, p. 92, No. 1, 1873.

are justly distinguished in the departments to which their lives are devoted, is found in the *argumentum ad hominem*.

Dr. Anstie highly recommends hypodermic injections of morphine in neuralgia.

If, now, we should say to him that we knew of a case where an injection of morphine had almost instantly caused most alarming symptoms, and of another case where it had apparently caused death, consequently we had resolved never again to use that method of treatment, he would reply that hypodermic injections had been tested for years at the hands of many of the best physicians of our time; that those who are most familiar with them are usually the most attached to them; and that, when properly administered with the caution that all potent remedial measures demand, and the skill that only experience can give, they need seldom or never do serious harm; and that the infinitely small chance of their doing harm, when thus properly used, is so far overshadowed, by the infinite relief which they unquestionably do afford, as to be hardly worthy of consideration in the practice of those who have made themselves familiar with their administration.

Dr. Brown-Séguard has, among very many other researches, deserved well of the profession for having given an explanation of the action of ergot on unstriped muscular fibre, and for having, on the basis of this explanation, suggested the value of that remedy in congestion of the spinal cord.

If, now, we should say to him that there are cases where, with well-defined symptoms of hyperæmia of the cord, ergot at once aggravates the symptoms, we should but state the truth of our experience. He could reply, however, with perfect justice, that just as there are those in whom a single strawberry will cause most disagreeable symptoms, or those to whom a mouthful of mutton is a mouthful of poison, just so there are those who, whatever their disease may be, cannot bear ergot; but that, when wisely used by those who know what they are about, it is a remedy of vast and various efficacy.

For hypodermic injections of ergot, substitute galvanization of the cervical sympathetic, and our reply is complete. There are those to whom electricity, however administered, is a perfect poison, and who were not born to be treated by this most potent of remedial agents. There are those who can bear it in well-nigh limitless doses.

There are those who can bear it and who are benefited by it, but only when given with delicacy and great caution. Now, it is possible to galvanize the cervical sympathetic in all three classes, except the first, without doing any serious injury, permanent or temporary. *Even those*

*who are the most susceptible to electricity, for whom this force can never be beneficial, can yet be treated by the method of central galvanization, with very mild currents and short sittings, and a rheostat of some kind to avoid interrupting the current, without any permanent or temporary injury.*

All our most potent remedies are dangerous when used dangerously

4. That the cases which have been treated by galvanization of the brain have been so carelessly and unscientifically studied, and so recklessly reported, that they have no scientific value. Dr. Cyon, in particular, declares that the observations that are given as proofs of the curative effects of galvanizing the brain are valueless. This statement is unfair. What is true of certain electro-therapeutists is not true of all. The therapeutics of galvanization of the brain have been studied by men who have been trained to the habit of close and discriminating observation; who recognize and bear constantly in mind the enormous complications that beset all therapeutics; who have worked under the gaze of watchful skeptics, and with the everlasting motto, *post hoc ergo propter hoc*, incessantly ringing in their ears; men, too, who have carried conscience into science, and have reported the results to the world just as they were revealed to them.

It is of very little practical consequence whether these effects are due to the direct passage of the current through the brain or to the reflex action of the current on the brain through the sensory nerves. Reflex action comes in to explain the therapeutic effects of electricity, however and wherever applied. Granting for one moment, what is not true, that mild currents cannot penetrate the brain, this would be no reason whatever for abandoning the electrical treatment of the brain so long as experience shows that benefit is derived thereby.

## CHAPTER XIII.

### THE USE OF FRANKLINIC OR STATIC ELECTRICITY.

THE two great obstacles to the use and popularization of Franklinic electricity have been: 1, That the necessary apparatus were bulky and expensive; 2, That they were more or less dependent upon atmospheric conditions, and therefore uncertain in their action. The first of these objections still holds, but the other no longer exists.

With the apparatus to be described we are able, at all seasons and in all kinds of weather, to obtain this form of electricity in sufficient quantity for therapeutic purposes. Notwithstanding this, however, there is one disadvantage under which we occasionally labor in the use of Franklinic electricity, and this is, that although the machine itself works well, the condition of the external atmosphere is such, at certain seasons, that the stored electricity in the insulated body is abstracted too quickly. It is mainly in the months of July and August that this difficulty occurs.

*Apparatus for Franklinization.*—The best apparatus for the generation of Franklinic electricity for medical purposes is the Holtz machine. This contrivance, although a great advance over the old-fashioned cylinder machine, still proved inoperative during most of the summer months at least, and frequently ceased to act for awhile, even in winter.

Vigorous has recently been experimenting in this direction in Paris, where it has been found that if the apparatus is covered with a tightly fitting glass case, in which is placed a quantity of chloride of calcium, which absorbs all the moisture of the air, electricity can be generated with more or less readiness in all kinds of weather.

The attention of the profession in this country was first called to this useful contrivance by Dr. W. J. Morton.\* The machine consists of two stationary and two revolving glass plates, giving a large quantity, and a spark of eight or ten inches.

Formerly but a single revolving plate was used, which yielded a

\* New York Medical Record, vol. xix., No. 14.

lower tension and less quantity ; now, however, machines of three, and even four, revolving plates are constructed, and any amount of force can be readily obtained.

For almost all practical purposes the four-plate apparatus with its stationary wheels twenty-four, and its revolving wheels twenty-two inches in diameter is sufficient. This apparatus is represented in Fig.

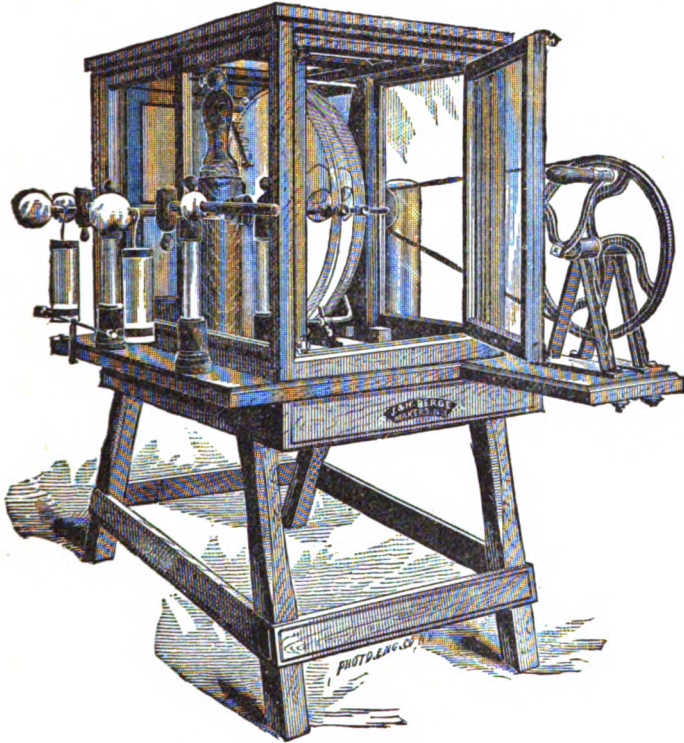

FIG. 100.

100. The machine may be operated by steam or water motor, or by hand.

Franklinization, as this method of treatment is now termed, may be given in several ways, each differing in the effect produced.

*Insulation.*—In the administration of Franklinic electricity, insulation is the first step taken, and to this end the patient is seated upon a platform supported by glass legs, and connected by a brass rod with either side of the machine, according as we wish to give a positive or a negative charge. As in the administration of dynamic electricity, so

in the treatment by Franklinic electricity, the effect produced is due to what is termed a difference of potential. In hydrostatics the standard level of our measurement is the sea, and in electro-statics the earth, and in the same way that we have levels above and below the sea, and temperatures above and below zero, so we have potentials *above* and *below* the earth's potential, termed respectively positive and negative potentials. In treating a patient, then, by insulation, we simply change his potential to a higher or to a lower one than that of the earth, according as he is placed in communication with the positive or negative condenser. To use a homely phrase, the electricity is, as it were, pumped into the body, and its silent reception, and as silent and more gradual discharge to the surrounding atmosphere, produces in most persons effects that are very agreeable. The hair of the head stands out in all directions, accompanied also by a pleasant vibratory sensation, if at the same time the discharging knobs are brought in sufficiently close communication.

The pulse may be slightly accelerated and the face flushed, while frequently it is observed that a slight but gentle perspiration appears.

This condition may be kept up for about twenty minutes, or until an agreeable feeling of drowsiness is experienced.

If, while in this condition of insulation, the brass rod connecting the insulating stool with the machine, be held lightly in either hand of the patient, and the discharging rods brought near together so that a constant discharge takes place between them, the sensation experienced by the patient is similar to that resulting from the administration of a feeble faradic current.

In those patients who are especially susceptible, this mild and simple method of treatment is frequently of much value. It is slightly tonic and refreshing in its action, and may be used as a tentative method before proceeding to the more positive and effective treatment of the spray, sparks, and shocks, or the general surface stimulation that is so admirably obtained by the use of the roller. Usually the effects experienced are very slight indeed, but in several instances I have observed some curious phenomena, and notably in one of my cases where the patient was suffering from the peculiar sequelæ of cerebro-spinal meningitis described elsewhere. Treatment by insulation was invariably followed by an overpowering tendency to drowsiness, which would continue for half an hour or more.

*Franklinization by sparks or spray.*—The patient being in the condition of insulation just described, sparks can be drawn from any portion of the body by the near approach of a conducting substance.

Fig. 100*a* represents the operator in the act of drawing sparks from the patient seated upon the insulating stool.

Brass balls of various sizes (mounted on glass handles, held by the operator), connected by a brass chain with the ground, or, better still, with the nearest gas or water-pipe, are usually employed. Fig. 100*b* represents the ball electrode ordinarily used.

The size of the sparks drawn from the body may be graduated in size and length ; and in strength, from a slight tingle to the sharp impression that accompanies a large spark passing through several inches of intervening air. The body varies much in its susceptibility to electrical

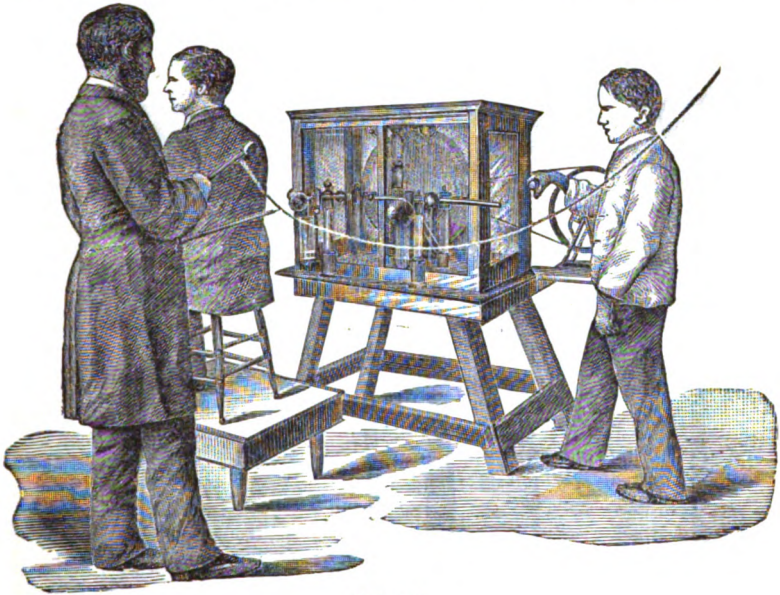

FIG. 100*a*.

influences, and as in the use of dynamic electricity, and especially the induced form of it, so in the use of Franklinic electricity by means of sparks, the operator should subject his own person to its influences until he is thoroughly aware in what regions these strong sparks are not disagreeable, and in what regions they are painful. A large variety of electrodes besides those represented in the accompanying cuts may be used ; but aside from special forms for the ear, mouth, nose, etc., the ball electrodes of metal and of hard wood, and the pointed rod for the spray or electric wind, are, as a rule, sufficient. It is unnecessary for the patient to remove any of his clothing, as the sparks pass readily through the thickest fabrics.



At the point where the sparks spring from the skin to the electrode a whitish spot will be at first noticed, and in some cases they very closely resemble the ordinary urticarial wheals followed by erythematous blushes which soon disappear. When in place of a round ball, a pointed rod (Fig. 100c) is brought within a few inches of an insulated body already charged, we obtain the effect called the electric wind or spray. This is due to the silent discharge of the electricity that has accumulated in the insulated body.

The air is agitated between the electrode and the body of the patient, and the sensation is not only very pleasant, but the results that follow its use are often very efficacious.

*General Franklinization.*—On the same principle that we apply the

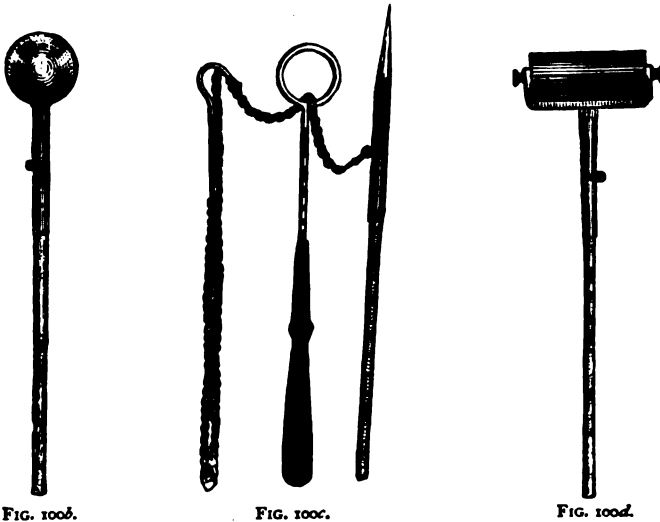

FIG. 100b.

FIG. 100c.

FIG. 100d.

faradic current to the whole surface of the body, calling it general faradization, so we can make similar use of the franklinic electricity, and very properly apply the term General Franklinization.

This is accomplished by means of the metallic roller (Fig. 100d), although it is by no means so generally effective, and it is certainly far less agreeable. It directly excites the cutaneous nerves, and has also a powerful reflex action. When the roller is used upon the bare skin, the conduction is so perfect that no sensation is appreciated. It is only when the clothing intervenes, acting possibly as a sort of Leyden jar, that the peculiar pricking sensation is observed. It is needless to say that to obtain the best therapeutic effect of the roller, it should be applied over the clothing.



*Shocks from the Leyden jar.*—These are produced by bringing the body, or that portion of it upon which we wish to operate, in the circuit between the outer and inner coating. A shock may be sent through the arms and chest by placing one hand on the knob connecting with the inner coating (containing the positive electricity) and the other hand on the outer coating of the jar containing the negative electricity. A shock may be sent through the pelvis by applying one end of a branched conductor, connected with the inner coating, to the back, and applying the outer coating of the jar against the hypogastric region. In the same way the electricity from the Leyden jar may be localized in any part of the body. The shock is a violent method of treatment and is not usually called for.

In addition, a static induction current (simultaneously suggested by Drs. Morton\* and Bartholow†) can be obtained from a Holtz apparatus, and this has been suggested as a substitute for faradic electricity. It is claimed for this current that it produces maximum muscular contractions with a minimum amount of pain, and that the response is quicker than that from the faradic current. As for the first claim, it is difficult to see how it can be determined, since the ordinary faradic current, from the single coil apparatus especially, need seldom call forth pain in the production of muscular contractions. As to the alleged greater quickness of response, I have not as yet been able to satisfactorily form an opinion. The change in the apparatus for the production of this current is quickly and easily effected, and for the purposes of localized electrization it is useful. For general faradization, however, I can quite confidently assert that it is far inferior to the current produced by the best faradic apparatus.

From franklinic electricity tonic and sedative effects of a very interesting and positive nature can be obtained either by insulation, by sparks, or the use of the roller. Speaking from a considerable experience with this form of electricity, I should say that, while its constitutional tonic effects are unequal to those that follow general faradization, when this method is carried out properly, with due attention to detail, yet, as an adjunct or supplement, it is invaluable. It is one of the familiar things in medicine that a remedy which at first acts well may, after a time, prove inefficacious, rendering it necessary to resort to some other remedy of the same class. This is true in regard to the dynamic and static forms of electricity. Occasionally cases of nervous exhaustion, as well as other forms of disease, after improving to a certain

\* New York Medical Record, April 2, 1881.

† Manual on Medical Electricity, 1881.

point, under the influence of galvanism or faradism, hang fire, as it were, but by submitting the patient to the action of franklinization a new impulse seems to be given. In this way, one treatment supplementing and re-enforcing the others, results are obtained far more satisfactory than could possibly follow the exclusive use of general or localized faradization, central galvanization, or franklinization. Pain is sometimes relieved by franklinization after both galvanism and faradism have failed, but this is not the rule. The pain of muscular rheumatism, however, is relieved by this method sooner and more effectually than by the others. For this purpose, the treatment by the roller, which exercises a generally stimulating effect over a broad surface, is superior to the treatment by sparks.

In the various forms of true neuralgia, franklinism is not comparable in power to galvanism. The pain that the former is frequently so successful in subduing is generally of a chronic character, confined to no special nerve-trunks, dull and aching in character, and with no tenderness on pressure. In these cases I have long known that faradism was superior to galvanism, but more recent experience has convinced me that franklinization is more efficacious than either. In the enlarged joints of subacute and chronic rheumatism, and to excite the process of absorption in chronic synovitis, the treatment by sparks is frequently more efficacious than either faradization or galvanization. In old contractions, and in cutaneous anæsthesia, franklinization frequently possesses advantages over the others.

In locomotor ataxia, and in systemic diseases of the spinal cord in general, it is rendered probable by a number of suggestive cases that much more can be accomplished by the use of franklinic than by dynamic electricity.

In electro-diagnosis franklinic electricity is of but limited value, those qualitative and quantitative changes which are so important as indicating structural degeneration, being satisfactorily produced only through the action of the two forms of dynamic electricity.

Valuable as is franklinic electricity, it has a more limited range of usefulness than dynamic, and the more strongly this fact is impressed on the professional mind the better. He who begins with franklinism the study and practice of medical electricity, begins at the wrong end. Let him first master dynamic electricity, and then supplement his knowledge and experience in this direction by franklinism. The differential indications for the use of galvanism, faradism, and franklinism, may well demand the closest scrutiny, for on the accuracy with which we estimate these indications will largely depend the success of our efforts.

## CHAPTER XIV.

### ELECTRIC BATHS.

A METHOD of employing electricity that has long been popular among the laity, though it is not yet fully introduced into science, is the *electric bath*. The methods of giving electric baths are various. The requisites are a bathing tub of some form, partly filled with water, contrivances for sending the current—either faradic or galvanic—through the water in which the patient is immersed. An electric bath can be extemporized in any ordinary bath-tub. The patient may rest his feet on one pole in the water and hold the other pole in his hand. In that position the body of the patient becomes part of one or the other pole, and the current flows through him from one pole to the other, just as it would if there were no water in the bath; or at most the only effect of the water is to thoroughly saturate the part of the body in contact with the pole in the bath. This method is, of course, exceedingly crude, and can scarcely have any conceivable advantage over a similar position of the poles outside of the bath, and yet it has been not a little used.

Mr. Russell uses the following form of electric bath. The tub is of the ordinary shape, but the metallic connections are so made that the current cannot avoid passing through the body of the patient. One pole—a broad copper plate—is at one end of the tub, constituting a part of its lining surface, and the other pole—also a broad metallic plate—is placed at the other end. Both plates are under the water. At the head of the tub a board is placed, at a little distance from the pole. This board has in it a slit of moderate size. Against this slit rests the back of the patient, while his feet may or may not press against the copper plate at the other end of the tub. By this arrangement the current can be directed through the back of the patient, and from the back through the body and lower limbs. Indeed, the back of the patient fits so closely and snugly into the slit of the wooden rest, that the current, if it pass at all, must go through the body.

In regard to the electro-conductibility of the body as compared with water, we have already spoken. The human body is composed mostly of water, holding in solution various salts; it, therefore, conducts bet

ter than water of the same temperature ; and on account of this superior conductivity of the living human tissue a considerable portion of electricity must go through the body whenever it lies in a bath, even though it does not touch either pole. That the body conducts better than the water is proved by this experiment, which we have often made. Place both hands, at some distance apart, in a bath through which a current of considerable strength is running, and a sensation will be distinctly felt in them. Bring the hands, still immersed, very close to each other, and the sensation will be much diminished. When the hands are far apart a considerable portion of the current passes through the body from one hand to the other. It prefers this much longer and roundabout road to the direct path through the water.

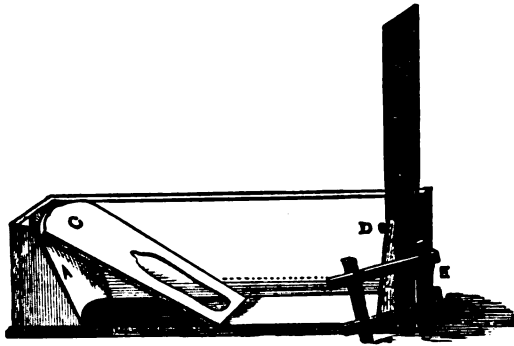

FIG. 101.  
Electric Bath.

In the arrangement that Russell uses (Fig. 101), if the patient presses his feet against the copper plate at the lower end of the tub, his body becomes a part of the pole that is attached to that plate, be it positive or negative.

Dr. Justin Hayes, of Chicago, has a somewhat different form of electric bath. In the sides of the tub and near the bottom are a number of electrodes connected with the battery. These electrodes are so arranged that the current can be sent through any one or all of them, and thus be localized on the part that specially needs treatment.

This method of using electricity, which is called the electro-thermal treatment, is carried out by Dr. A. P. Peck, of Chicago, who has obtained excellent results from its employment.

The study of the comparative practical advantages of these different forms of baths is of course beset by many complications.

*Effects of the Electric Bath.*—In regard to the therapeutic effects of the electric bath, we have these remarks to offer :

1. The stimulating, sedative, and tonic effects of electricity are obtained more or less by all forms of electric baths ; not only those where the current is localized in some part of the body, but those where it is generally diffused without regard to localization and without regard to current direction, exert, there is no question, more or less the special and distinctive physiological and therapeutical effects of electricity. Those forms of baths that admit of localization of the current seem to us to be far more scientific and rational than those that do not admit of such localization, but all forms are capable of affecting the system, for electricity cannot pass through the body without doing more or less good or evil.

2. The question whether electricity, administered in any of the forms of baths yet devised, has any therapeutical advantage over the ordinary methods of using electricity—as localized faradization and galvanization, general faradization and central galvanization—has not yet been established. Even if it should be proved that in certain diseases or certain conditions the electric baths are slightly superior to ordinary electrization, the further question would still arise whether this advantage is sufficient to compensate for the longer time and greater labor and inconvenience of the baths. The question is one of exceeding complexity—for the therapeutical effect of the water is combined with the therapeutic effect of the electricity, and to eliminate the one or the other is no easy task. Enthusiastic advocates of the baths sometimes make the same mistakes as the advocates of Franklinization, or the use of static electricity, of assuming that the results which they undeniably obtain, and which are sometimes most satisfactory, could not just as well have been obtained by a proper use of electricity in some of the ordinary methods.

It is claimed that the baths will be borne by temperaments that will not bear ordinary electricity. This claim may possibly be just, and yet the difficulty of demonstrating it is very great ; for those who take the baths and are benefited by them may most likely have been improperly treated by the other methods, and thus fall into the delusion that the baths are *per se* more bearable than ordinary electrization.

The true and only way to determine this question is for those who are masters in electrology to try the baths, side by side with their other methods of using electricity ; just as they try the two currents and the different methods of using them on the same patients and on different patients, and in a wide variety of diseases. Observations of this kind,

to be of real value, must be not only numerous, but extended over a long period.

The question whether substances can be introduced into the body or removed from it by electricity, will be discussed in the section on electro-surgery.

*General Rules for giving Electric Baths.*—In the use of electric baths we should be guided by some of the same general principles that guide us in the use of electricity by other methods. The temperament of the patient should be studied, and in the length and strength of the baths and in the frequency with which they are given we should be directed by the peculiarities of each case.

It is not well to take an electric bath just after a full meal, nor is it usually well to take exhausting exercise immediately after a bath, especially for the delicate and nervous. The temperature of the water should be about that of the body, and may range between 95 and 105° Fahrenheit. The patient may remain in the water from 5 to 25 minutes. There appears to be no danger of catching cold after taking an electric bath, even when the water is quite warm. One effect of the electricity would appear to be to give tone to the cutaneous vessels, so that there is less liability to take cold than after a simple warm bath.

## CHAPTER XV.

### HYSTERIA AND ALLIED AFFECTIONS.

UNDER this head we include hysteria, in the ordinary sense of that term; neurasthenia, or nervous exhaustion; hypochondriasis and melancholia; spinal irritation, with the manifold symptoms with which it is associated; insomnia; and astraphobia, or fear of lightning.

We give hysteria and allied affections a prominent position in the clinical portion of this work, because it is a class of diseases for which electrical treatment is especially adapted, and in which its success is most remarkable. This fact is not generally appreciated, for the reason that the profession have looked upon electricity as a stimulant merely, and have not fully recognized its sedative and tonic properties, and hence have confined their attention largely to paralysis, as the one disease above all others to be treated by this agent.

*Electro-diagnosis.*—Usually, though not necessarily, there is excessive sensitiveness to the electric current in all parts of the body. Patients sometimes can bear only the mildest currents. In some cases even a mild current will not be borne on the middle of the back, which, in health, is usually so little sensitive. Reflex sensations may be observed during electrization of hysterical patients. Irritation of the diseased side of the body may be sensitively felt in the healthy side. *Sometimes there is capacity for bearing very strong currents without injury, even when there is great hyperæsthesia.* The electro-diagnosis of hysterical paralysis will be presented under that disease.

*Treatment.*—Hysteria is a constitutional disease, and demands constitutional treatment. To attempt to chase after and direct the application of electricity to each special symptom as it appears, is unphilosophical and usually unsuccessful. General faradization and central galvanization are methods of electrization that are indicated for hysteria. Under whatever symptoms it may be developed, our chief and best results have been obtained by these methods. This general treatment does not, of course, dispense with localized electrization of paralyzed muscles, or special attention to any localities where the disease is

for the time directed. Diseases of the sexual organs, hysterical hic-cough or cough, aphonia, or incontinence of urine, may sometimes need localized electrization; but these symptoms frequently yield under general faradization or central galvanization, even when no special attention is given to the diseased parts. In nearly all cases, except, perhaps, long-standing paralysis, it is much better to dispense with the local than the general treatment. There are cases, however, in which the symptoms of rigid contractions of certain muscles are most persistent and painful in character. In such conditions of the affected muscles galvanization should never be omitted. In cases of extreme hyper-æsthesia it may be necessary, as Benedikt advises, to place the patient under the influence of an anæsthetic while the application is made. Strong currents do not appear to be injurious in such cases.

*Prognosis.*—The behavior of hysteria under electrization is as capricious and inconsistent as are its symptoms. Some cases yield to general electrization with wonderful rapidity; others, apparently no worse, are singularly obstinate. On the average, the prognosis is so favorable that no case should be abandoned without a fair trial of this method of treatment. Under peripheral electrization the results are usually unsatisfactory, since the relief of the local symptom is by no means a cure of the morbid constitutional condition.

*Violent hysterical symptoms dependent on suppressed menstruation alleviated by two sances of general faradization and localized galvanization.*

CASE I.—A most violent and persistent case of hysteria, in the person of a married lady, aged 40, came under our observation through the kindness of Dr. Oliver White. The patient was in bed, suffering from violent paroxysms of alternate weeping and screaming. The hands and feet were cold, the pulse feeble, and the pain in the head was constant, and of the most severe character.

These symptoms had continued for nearly forty-eight hours, and in order to avert serious consequences it seemed as if in some way relief must soon be afforded. The menstrual period was delayed nearly two weeks, and to this circumstance it was possible, in part, to attribute the attack. The patient was submitted to thorough general faradization, and immediately after a galvanic current from eight cells was as nearly as possible localized in the uterus. These efforts were followed by decided alleviation of the symptoms, and a tolerably quiet night was the result. The menses, however, did not appear, and on the following night we gave again the same treatment, slightly increasing the tension of the galvanic current. Before morning menstruation became manifest, and there was no further evidence of nervous disturbance.

Nearly a year subsequently this patient experienced another attack of like character, and substantially the same treatment again relieved her completely within forty-eight hours.



*Hysteria of one year's standing in a married lady, following parturition; strange and indefinite sensations in the legs; tickling, crawling, pricking, waving, beating, pounding, heaving, rolling sensations over head and body; imaginary swelling of the body; fits of weeping and great despondency—Rapid and decided improvement under central galvanization with strong currents, after failure of general faradization—Cod-liver-oil emulsion and counter-irritation used at the same time.*

CASE II.—Mrs. B., a married lady, with two children, was referred to us November 5, 1872, by Dr. Conkling, of Brooklyn.

The patient, though a lady of unusual intelligence and great strength of will, had for nearly a year been a victim to many of the worst symptoms of hysteria. The symptoms appeared ten days after the birth of her second child; up to that time her health had been almost perfect. She came from a family in whom there was some tendency to consumption, and she had lost two sisters by that disease. A short time before the birth of her second child, she had fallen down stairs and had struck on the back of her head. The query arose whether that might not have had something to do with her disease. The symptoms came on in the night, and quite suddenly. She became excessively nervous, almost wild, and the physician was sent for and succeeded in calming her; then followed a long catalogue of woes. On the top of the head was a constant sensation of shaking or agitation, or thrilling, as she described it, and heaving, rolling, beating, waving, pounding sensations were felt in the head and over the body. There had been many attacks of weeping; at all times, though naturally hopeful, she was cast down, and imagined she did not love as she should one of her children. The general nutrition, as usual in such cases, was well maintained.

The patient had tried, with great thoroughness, general faradization but without substantial service.

We used on her mainly *central galvanization*, combined with the use of cod-liver-oil emulsion, and mild counter-irritation over the tender vertebræ.

The patient, with all her nervousness, bore the *galvanic current in enormous doses*: it seemed to be impossible to injure her by over-electrization. We soon found that the stronger the currents, and the longer the applications, the greater the benefit. Even through the brain strong currents, now and then interrupted, did no harm. She soon began to improve, and continued to improve not only during the three months of treatment, but subsequently, and there was in this improvement a considerable degree of permanency.

In the above case there were facts of great interest. *First*, the extraordinary tolerance in a highly nervous patient of the galvanic current; and *secondly*, the supreme advantage of central galvanization over general faradization in severe functional diseases of the central nervous system.

Hysterical and analogous symptoms are both associated with and dependent upon recognizable uterine disorders, but in many cases, while these symptoms may be associated with and aggravated by such disorders, they are not by any means always dependent upon them.

During his service at the New York State Woman's Hospital Dr. Rockwell has found that symptoms of excessive nervousness, etc., which were supposed to be merely a reflex of local derangement, have frequently yielded to some form of electrization, before any manifest change has been observed in the condition of the sexual apparatus.

*Hypochondriasis (Pathophobia) and Melancholia.*—The distinction between hypochondriasis and melancholia is vital. The hypochondriac readily appreciates the character of any special disease from which he may suffer, but he has a most exaggerated conception of its importance and of its probable results. He talks much of his symptoms, and unceasingly seeks relief. The melancholic, on the contrary, possibly suffers from no appreciable disease; or if any evident structural or functional trouble exists aside from the recognized mental perversion, it is unheeded. As Maudsley expresses it, "the former committing a murder would certainly be hanged, the latter probably not." The tendency of the melancholic is frequently to suicide—the hypochondriac clings to life. Intellectual exertion is an impossibility for the melancholic; the hypochondriac, on the contrary, may lead the highest intellectual life.

The one suffers from such perverted habits of thought and feeling that the strongest and most natural affections may cease to exist; the other retains all the normal warmth of feeling towards friends and relatives.

Melancholia is a more advanced phase of mental perversion, and to this advanced and more serious condition hypochondriasis not unfrequently progresses.

There are reasons for believing that the sympathetic nervous system is largely at fault in cases of hypochondriasis; and that if not demonstrably diseased it is yet the *medium* through which disease of the other parts reacts on the brain, and produces molecular or other disturbance.

The two leading ideas that we here desire to impress are, *first*, that hypochondriasis is just as truly a disease, or, more strictly speaking, a symptom of disease, as dyspepsia, insomnia, chorea, neuralgia, paralysis, or insanity, and should be treated accordingly. The popular method of neglecting hypochondriacs altogether, or of administering *placebos*, is not scientific, and, except in rare cases, is not successful. *Secondly*, hypochondriasis, when not dependent on serious lesions of the central nervous system, is susceptible of relief and of positive cure under the skilful and faithful use of electricity. Still further, we believe—and the results of our own cases justify the belief—that cerebral disease of a more pronounced character itself may be relieved by electricity; and that that terrible form of hypochondriasis which is the precursor of

organic cerebral disease—the vestibule that leads to the dark and gloomy caverns of insanity—may be controlled or kept at bay by a persevering electrical treatment. (See chapter on Insanity.)

*Treatment.*—In hypochondriasis, general faradization, central galvanization, and galvanization of the cervical sympathetic, are indicated. We have obtained good results from all methods, though most of our cases were treated by the first and second.

*Hypochondriasis, with impairment of the functions of special sense—Weakened memory—Sensory symptoms in the extremities, with some loss of motor power, the result of excessive mental activity, and dependent in part on slight cerebral congestion—Improvement under general faradization and central galvanization—Relapse.*

CASE III.—Mr. M., an actor of twenty years' standing, was placed under our care by Dr. F. L. Harris. The patient was a temperate man, and so far as his profession permitted, regular in all his habits; but the character of his engagements had rendered it necessary for him to exercise his memory through a series of years to an unusual, and as the sequel proved to a most injurious, extent. Two months prior he began to observe that his intellectual powers were failing him. His memory became so impaired and his thoughts so confused, that he found it utterly impossible to "commit" anything new, or to recall readily certain "parts" that had been long perfectly familiar. He was hypochondriacal to the last degree, and at the same time his limbs became weak, and he complained of sensory symptoms in the tips of the fingers, much the same as those present after frostbite. The integrity of most of the senses was markedly impaired. Under seances of general faradization and central galvanization the annoying sensory symptoms disappeared; he gained entire mastery over his limbs, and was more hopeful and happy; his strength of vision became nearly normal, and when we last saw him there had been sufficient improvement in his intellectual faculties to enable him successfully to attempt a performance on the stage. We learned that during an attempt to perform on a subsequent occasion he became quite unable to pursue his part, and was led off the stage. This was sufficient to show that recovery was not complete; as to his condition after this we are uninformed.

*Pathophobia—Improvement under general faradization and central galvanization.*

CASE IV.—A very favorable result was obtained in the person of a young man aged 25. At all hours of the day he was annoyed by tinnitus aurium, and what to him seemed an audible voice telling him of evil to come. We submitted him to general applications of a powerful faradic current, and also to occasional galvanization of the brain, cord, and sympathetic. Some improvement followed. The most decided benefit was, however, derived from the method of galvano-faradization. The faradic current, full strength, from a Kidder apparatus, and at the same time the galvanic current from fifteen cells of Bunsen's battery were passed through and around the body by the method of general electrization. Improvement was now remarkably rapid. In the course of half a dozen applications every unpleasant symptom disappeared, and the patient has since remained perfectly free from any evidence of their return.

*Melancholia of two years' standing in a young married lady—Complete recovery under central galvanization after failure of persistent internal medication and general faradization.*

CASE V.—Mrs. Y., a married woman, aged twenty-five, came first under our observation October 8, 1871, in the seventh month of her pregnancy. Her mental condition was lamentable in the extreme. There was chiefly a perversion of the whole habit or manner of feeling, such as so frequently follows actual intellectual derangement. She confessed and bewailed her want of interest in or love for those who were nearest to her, and evidently suffered most intensely from a profound feeling of depression and misery—a vast and formless idea of utter desolation. The patient appreciated her condition, would reason concerning it, and acknowledge that there was nothing real to which she could point as a cause of her misery.

These wretched feelings were not altogether new, but for over two years had in a modified form annoyed her considerably. Bitten slightly by a favorite dog, she merged immediately into a condition that may be called hypochondriacal melancholia, with an exaggerated notion of the danger she had incurred. She had been treated persistently but without avail, and as a *dernier ressort* general faradization was attempted. It utterly failed in its effects, and in good faith the patient was encouraged to hope that with her delivery her mental balance would return. The child was born, and three months subsequently I was again called to see the mother, only to find her condition more aggravated than at any previous time. We now resolved to make use of central galvanization, and employed a current from six ordinary-sized zinc carbon-cells, with a sitting of four minutes. The patient was not at all improved by the *séance*, but seemed, if anything, slightly more sensitive to external impressions.

In a couple of days the same application was again tried, with the evident result of decidedly exciting her mind. A third effort was made with but three cells, from which the current was just sufficient in tension to call into action the sense of taste. From this trial the patient experienced undoubted relief, and at intervals of a day the application, without being varied excepting in the length of the *séance*, was repeated for some two months. Although during the treatment two or three slight relapses occurred, yet on the whole the improvement was steady and satisfactory, and at the close of the "central" treatment, when she was placed entirely in the care of Dr. William J. Donor for uterine difficulty, her recovery was complete.

*Neurasthenia, \* or Nervous Exhaustion.*—The derivation of the term *neurasthenia* is sufficiently obvious. It comes from the Greek word *νευρον*, a nerve; *α*, privative; and *σθενος*, strength; and therefore, being literally interpreted, signifies want of strength in the nerve. Under the name of general debility, it is a condition sufficiently familiar to every practising physician, and too frequently resists most obstinately all forms of internal medication. It is not to be confounded with *anæmia*, though it may be associated with it.

The one principle on which *neurasthenia* is to be treated is by the concentration of all possible tonic influence on the nervous system—air, sunlight, water, food, rest, diversion, muscular exercise, and the in

\* See monograph on this subject, by Dr. Beard.

ternal administration of those remedies, such as strychnine, phosphorus, arsenic, etc., which directly affect the central nervous system.

*Electrical Treatment.*—General faradization and central galvanization as an adjuvant to relieve more directly the symptoms of insomnia, headache, etc., which are so frequently associated with neurasthenia or after general faradization has failed.

The *prognosis* is usually more or less favorable. In nearly all cases of uncomplicated neurasthenia general faradization alone proves decidedly and sometimes rapidly efficacious. Beneficial results from either this method or central galvanization are so uniform in this condition that we have reason to suspect some unrecognizable organic disease in those cases that give no evidence of improvement after protracted treatment. Even the complicated forms, that are the result of incurable disease, may be much relieved. The cases that fail to be benefited by electrical treatment are those of lifelong standing, or in which the temperament contraindicates electrical treatment.

*Neurasthenia—Debility and attacks of sick headache—Immediate and rapid improvement under general faradization—Rapid increase in weight.*

CASE VI.—The power of general faradization to relieve neurasthenia and to cause increase of weight, was illustrated in a very pleasing and satisfactory manner in the case of a young physician whom we have treated during the autumn of 1869. He was 28 years of age, and for a long time he had been subject to severe and repeated attacks of nervous and sick headache. To use his own expression, he had been "living on a lower plane than was normal." Over-work and long confinement had reduced him to a condition of serious exhaustion, and when he called upon us in September he could not walk two miles without fatigue. Although 5 feet 9½ inches in height, he weighed but 112 pounds, and for many months there had been no sign of any increase. He had closely studied his own case, had been thoroughly examined, and had tried nearly every form of internal medication.

We began treatment by a mild and general application with the faradic current. He felt temporarily enlivened and exhilarated, but when he returned, two days subsequently, he stated that he felt no special benefit, although he had gained *one-half a pound in weight*. This change, slight as it was, encouraged him, for it had been months, and years even, since he had been able to detect any increase in weight. We may say here that he watched and studied his symptoms, and carefully ascertained his weight, from day to day, not as a hypochondriac at all, but as a scientific man, inspired not by any special faith in the remedy, but by an earnest desire to test for himself the tonic effects of general faradization. He continued to increase in weight with remarkable regularity and uniformity, and at the end of three weeks he found that he had increased nine pounds. When we last saw him his weight was 124 pounds. The improvement in his general condition had gone on hand in hand with the increase in weight. His appetite was keener and his digestion much easier. His attacks of headache still annoyed him, but his capacity for endurance had been greatly

enlarged. Within the last two years we learned from the patient himself that he had suffered no relapse.

In this case the applications were made very thoroughly all over the person, from the top of the head to the feet, and with a powerful current. Both the faradic and galvanic currents were used, chiefly the faradic. It is worthy of remark, also, that this patient always experienced a feeling of temporary enlivenment and exhilaration after each application, and sometimes the headache from which he suffered was driven away in the midst of the treatment.

We may say, also, that when he first came we prescribed oxide of zinc, by *exclusion*, because he had used nearly every other internal tonic. He took, however, but two or three doses of one grain each for the first day, dropping it entirely as soon as he found that he had increased half a pound in weight.

The above case we regarded as pre-eminently a typical one—a typical illustration of neurasthenia, and of the benefit that may be received from general faradization.

*Neurasthenia in a plethoric patient, caused by excessive application to business: Slow improvement under galvanization of the cervical sympathetic and general faradization.*

CASE VII.—Mr. A. was a short, stout, and remarkably plethoric man, aged 40. Through his active business life he had confined himself most closely to his duties, seldom taking a day for recreation, even during the heat of summer. Ninety years since he retired from business with greatly impaired health and strength. He was thought that perfect freedom from all care would be sufficient to restore his native vigor of constitution. On the contrary, he gained but little, if any. His general appearance was typical of perfect health, but ordinary exertion, either mental or physical, was sure to produce exhaustion. *His pulse was normal, and the patient plethoric rather than anemic.* It was impossible for him to read more than ten or fifteen minutes without becoming restless and excessively nervous, and exercise, such as walking, to the extent of a dozen blocks or so, would frequently produce complete prostration. His sleep at night was broken, and sometimes entirely destroyed. There was not the slightest evidence of organic disease, but the whole nervous system seemed to be unstrung. He had submitted to almost every method of treatment, both medicinal and hygienic, but had seldom experienced even temporary relief. We felt justified in encouraging him to hope for favorable results from treatment by electrization. With admirable perseverance and promptness he continued to visit us for two months, never, in a single instance, failing to keep an appointment.

At first, general applications with the faradic current were given every other day. At each sitting he seemed much invigorated, and for several hours he experienced a degree of strength and lightness of spirit such as he had been a stranger to for years.

These effects, however, seemed but temporary, for the old lassitude invariably returned; consequently, after three weeks of treatment with the faradic, we resorted to a weak galvanic current.

The negative pole was applied to the epigastric region, and the positive to the back of the neck, near the seventh cervical vertebra and also along the anterior border of the scalenus anticus muscle, in order to affect more thoroughly the great sympathetic and pneumogastric.

Sponge electrodes were used, and the applications were prolonged sufficiently to produce an intense redness and an acute burning sensation under them. By this method the immediate effects were not so marked as when the faradic current was used, but the relief afforded was more permanent.

For the first time, his sleep became more quiet and sound, and during the day following an application he was able to exercise both mind and body harder and longer than usual. He now submitted to treatment by galvanization every day. Week by week he gained very perceptibly in vigor, until, after having received the galvanic current some twenty-five times, he left us to spend the summer months among the mountains. He did not discontinue treatment with a nervous system perfectly strengthened, but he had regained approximately the usual portion of mental and physical endurance enjoyed by persons of his years. Whereas, before treatment by electrization, he was not able to walk half a mile without fatigue, nor read more than ten or fifteen minutes without suffering from nervous irritability, after treatment he enjoyed and derived benefit from walking several miles in the day, and could confine himself to a book for an hour or two without experiencing any symptoms of mental exhaustion.

At the date of writing, 1874, the patient enjoys a fair degree of health, and claims to have retained all the benefit he derived from treatment.

*Neurasthenia, complicated with anæmia, dyspepsia, spinal irritation, and hypochondriasis, treated by general faradization and central galvanization—Improvement and subsequent relapse.*

CASE VIII.—Mr. E., a tall, spare man, aged about 50, was sent to us by Dr. Gurdon Buck. He was a gentleman of wealth and leisure, and for several years had been entirely free from any of the cares of active business life. He was frequently troubled with indigestion. At times he would seem to regain some vigor, and would exercise to a considerable extent without experiencing inconvenience, but as a rule the most ordinary mental or physical exertion was followed by extreme exhaustion. Pains in the lumbar region of the back were of frequent occurrence, especially after passing a sleepless night. There was, however, no spinal tenderness. He was a good barometer—an east wind would almost drive him to despair, and so long as it lasted he could hardly muster strength or inclination to leave his couch. As soon as the wind changed and the sun appeared, he observed an immediate amelioration of his dreadfully depressed condition.

Our patient experienced the exhilaration that so frequently follows a general application of the faradic current.

Although at first this invigoration was of but temporary duration, the effects of the treatment were gradually prolonged after each sitting, until, in a much shorter time than is usually the case in conditions such as the one under consideration, the patient enjoyed a good degree of health.

During damp, enervating days especially, central galvanization prevented exhaustion far more successfully than faradization. The patient retained the nervous vigor that he had gained for many months; subsequently, however, he relapsed, and again placed himself under our care. He was decidedly benefited by this second course of treatment, but not to the same extent as at first. When last seen he had retained a measure of improvement, but was extraordinarily susceptible to atmospheric changes.

*Nervous exhaustion of long standing, associated with severe neuralgia. Slight relief during two months of general faradization—After-effects of the treatment, manifested by rapid improvement in all her symptoms.* (See p. 294.)

CASE IX.—Mrs. B., a young married lady, had for a long time suffered most intensely from pains of a neuralgic character. The head was the seat of greatest suffering, although the distress extended with more or less severity to every part of the body.

Her strength was much reduced, so that she was unequal to the slightest exertion beyond a few ordinary household duties and an occasional walk in the street of one or two blocks. Not the slightest evidence of organic disease could be discovered by her physician, Dr. George A. Peters, who, having seemingly exhausted the resources of medicine, requested us to try the efficacy of some method of electrization.

As the extreme debility was evidently the proximate cause of the neuralgia, we decided upon general faradization as the proper method of treatment, and accordingly submitted her to a very gentle application. She was one of those patients frequently encountered, who are so susceptible to the current that it was our aim to give of the electrical influence the minimum that could be actually felt by the patient, rather than the maximum that it was possible for her to bear without decided discomfort.

During the months of October and November, 1870, we gave thirty-six applications, which somewhat lessened the severity and frequency of the pain, without appreciably improving her strength. We proposed to her physician, therefore, to discontinue our efforts for a while, hoping that the favorable after-effects of electrization, that are so often seen, would show themselves in this case. We were not disappointed. The patient soon began to amend, until the improvement was most marked, both in the almost complete cessation of the neuralgia and in an approximate return of normal strength.

*Spinal Irritation.*—Spinal irritation is one of those names which, like hysteria, have become the recognized property of the profession, against the actual or implied protest of nearly all who employ it. It is a part of the hysterical constitution.

The term spinal irritation, originally proposed by Dr. Brown, of Glasgow, and described and illustrated in detail by G. T. P. Teale, in 1829, and the Griffin Brothers in 1844, is now pretty generally understood, in England and America at least, to express a tolerably well-defined morbid condition, of which one of the principal symptoms is spinal tenderness.

*Differential Diagnosis.*—Spinal irritation almost always forms a part of hysteria and neurasthenia, constituting, as it were, a subdivision or accompaniment of them, and is only entitled to the honor of distinct nomenclature by itself *when the spinal tenderness and the symptoms that directly flow from it overshadow other accompanying conditions.* Close examination would reveal that very many of the cases in practice that are variously classified under hysteria, anæmia, etc., have a sufficiently marked tenderness of the vertebræ to be regarded as examples of spinal



irritation; and if treated accordingly, would recover more rapidly than under the methods usually employed. The best confirmation of the diagnosis is the very favorable result of judicious and varied treatment devoted specially to the tender spots on the spine.

Between spinal irritation and spinal meningitis or congestion the distinction is oftentimes purely one of *permanence and degree*. In both conditions there may be pain and heat in the spine, neuralgia or paralysis of the limbs, plantar heat and anæsthesia, constipation, feeling of pressure or constriction in the chest, and stiffness of the neck, etc. It is distinguished from myelitis by the absence of other necessary symptoms. The contractions of muscles in spinal irritation are less painful than those of myelitis.

*Pathology.*—In spinal irritation, as in cerebral irritation, it is probable that there may be either anæmia or hyperæmia. That many of the cases of spinal irritation depend on passive hyperæmia of the cord, is rendered probable.

1. By the feeling of heat and burning at the seat of the irritation.
2. By the fact that this pain is increased at night, when the patient is in a recumbent position.
3. By the fact that it is relieved by measures that relieve congestion, as dry and wet cupping, and by blisters over the tender vertebræ.

On the other hand, reasoning from analogy and from what we know of the relation of the sympathetic, it is proper to assume that anæmia may account for many of the phenomena of spinal as of cerebral irritation. This assumption is strengthened by the fact that very many of the patients who have spinal irritation are more or less anæmic. And yet, reasoning from the history of the cases, and from the results of treatment, we are inclined to the opinion that anæmia exists only in a minority of the cases of spinal irritation; that in the majority of instances there is more or less at least *temporary passive* congestion of the cord and of its membrane; and that in all cases of doubt it is safe to assume the existence of hyperæmia, and to guide the treatment accordingly.

It is not necessary to assume that this hyperæmia of the cord is a constant condition. Except in the severe and long-standing cases, it is probably not so, but is more or less evanescent, temporary and metastatic. This may distinguish it from spinal congestion, which is a fixed condition. Temporary congestion of the cord, as of the brain, the genitals, the eye and the ear, may perhaps be easily excited by irritating causes. It is not unreasonable to suppose that anæmia and hyperæmia may alternate in the patient, and in the same day or hour.

*Electric examination* in spinal irritation may sometimes reveal tender spots on the spine that are not indicated by pressure.

*Treatment.*—Electric treatment consists in general faradization, galvanization of the spine and sympathetic and central galvanization.

Our experience in a great number of cases, since the first edition of this work, convinces us that in galvanization of the spine the positive pole acts better than the negative in the treatment of this affection. To depend, however, on localized galvanization alone is illogical, since the disease, though for the time specially localized in the spinal cord, is usually simply but a development or manifestation of the nervous diathesis, in which the whole system shares.

*Prognosis.*—Under electric treatment alone, the prognosis of spinal irritation is usually favorable for a relief, and sometimes for permanent cure.

It is, however, of great advantage in all severe or long-standing cases, to combine with electrization, counter-irritation (very small blisters, or tartar-emetie ointment) over the sensitive vertebræ, and the internal administration of phosphorus or other stimulants.

Comparative rest of brain and muscles is an important, though not indispensable, aid to treatment. The disease is quite prone to relapse, especially under bad hygienic surroundings. Under combined treatment, consisting of blisters to the spine, phosphorus, strychnia, and electrization, the majority of cases will rapidly improve.

*Spinal irritation of four years' standing, with excessive tenderness in the lumbar region—Decided relief from general faradization.*

CASE X.—Mrs. —, aged 24, was sent to us January 4, 1868, by Dr. Sewall to be treated for pain, with most excessive tenderness, over the lumbar vertebræ. The symptoms had been particularly distressing since her confinement, two months previous, but had annoyed her more or less for four years. United with this spinal tenderness there was considerable debility, that made a walk of half a mile a burden; gastric uneasiness, feeble appetite, insomnia, and, in general, the characteristic features of the nervous constitution.

*Electric examination* revealed a very great tenderness over several of the lumbar vertebræ; only a feeble current could be borne at all, even with large, soft sponges. No other abnormal condition was found beyond a general hyperæsthesia, which is usual in such cases. The tenderness was so great that even the weight of the hand was distressingly painful.

We began treatment by general faradization, with special reference to the tender spot in the spine. At this locality we used a stable increasing current, beginning with a current scarcely perceptible, and increasing the strength up to the point where it could be comfortably borne. The patient shortly improved under this treatment, though not without relapses whenever she attempted any important exertion. From

week to week the tenderness became less marked, until the vertebræ were no longer painful under moderate pressure, and a much more powerful current could be borne with ease. Agreeable temporary relief followed each application—an observation which we have frequently made in spinal irritation.

At the end of two months the patient was dismissed very much benefited.

*Hyperæsthesia of the cervical and upper lumbar vertebræ caused by exposure to the sun—Great susceptibility to electricity—Improvement under general and localized faradization and galvanization.*

CASE XI.—Rev. Mr. F., aged 30, was referred to our care, March 9, 1868, by Dr. Gurdon Buck. For several months before he had been complaining of pain and heaviness in the back of the neck, that had compelled him to resign his pastoral charge and abstain from all sustained mental exertion. The symptoms dated from an exposure to the sun on a very hot day. The patient was large, tall, well-formed, and apparently very robust. All the functions seemed to be tolerably well performed; but sustained mental exertion was almost impossible. He had been treated faithfully by counter-irritation, in the shape of wet cupping, and had derived positive benefit therefrom.

*Electric examination* indicated some tenderness on the upper cervical vertebræ, and also in the upper lumbar; but this tenderness was not excessive, and a current of fair strength, so far as the vertebræ were concerned, could be readily borne without discomfort; nor were the vertebræ so painful as they sometimes are found.

But in one respect his behavior under the electric examination was peculiar. The sensation produced by a mild galvanic current over the upper cervical vertebræ was painfully felt in the forehead, indicating a morbid irritability of the central nervous system, since in health such a phenomenon does not appear. That this morbid irritability was in some way related to the sympathetic, or that, at least, the sympathetic was the medium through which it was manifested, was rendered probable by the fact that mild faradization or galvanization of the affected part caused a very profuse perspiration on the hands and feet. This same effect we have also observed in a case of hysteria.

Strong as the patient appeared to be, it was necessary to treat him with mild currents and short applications. By turns and in succession we tried the various methods of electrization, with both the faradic and galvanic currents, and with important though not brilliant results.

After a treatment extending by intervals through three months, the patient left for a visit in England, where he remained nearly a year, still slowly improving.

Great susceptibility to electricity, as in the above case, is frequently observed after sunstroke.

*A chronic condition of irritation and hyperæsthesia of the spinal cord greatly benefited by general faradization, in conjunction with galvanization of the sympathetic and spine.*

CASE XII.—A young lady, daughter of a physician, who had suffered for many months from symptoms both of congestion and irritation of the spinal cord, was placed under our care by the advice of the late Dr. H. D. Bulkeley. Tenderness was

manifest over the cervical-dorsal and lumbar regions. The patient complained of shortness of breath, numbness and tingling in the hands and feet, cough, nausea, with neuralgic pains around the loins and in the extremities. A very decided loss of power was manifest in the lower limbs, so that it was impossible to take more than a few turns around the room without fatigue. Under the tonic influence of twenty general applications of the faradic current, the patient very decidedly improved. The tenderness along the spine decreased, and in the cervical region disappeared altogether.

The shortness of breath, the numbness and tingling, together with the neuralgic pains, became less marked, while the strength so far improved that she was able daily to take short walks of several blocks, and to ascend the stairs with comparative comfort.

We now resorted to the galvanization of the sympathetic and the spine—spinal-cord current—which were followed by an improvement more marked than it was possible to obtain from the faradic current alone.

The above patient subsequently relapsed after a severe fall and was again treated with great perseverance and even better results, so that she is now in perfect health, and is indeed unusually vigorous. The case illustrates the record that may follow great perseverance in electrical treatment.

*A condition of tingling, pricking, and a disposition to paralysis of the legs, dependent on irritation and hyperæmia of the cord, decidedly relieved by galvanization of the sympathetic and general faradization.*

CASE XIII.—Mrs. W., aged 44, whose physician, Dr. H. Gregory, advised treatment by electrization, was suffering from pricking sensations in the arms, and from tingling and numbness of the lower limbs and feet. In the legs, also, there was a decided “*disposition*” to paralysis, as manifested by a feeling of weight in the effort of walking.

Pressure along the spine disclosed a tender point, at about the third dorsal and second lumbar vertebræ. These conditions of tenderness, tingling, and weight in the lower limbs seemed to indicate not only an irritation, but also a hyperæmia of the spinal cord. Galvanization of the sympathetic and mild general applications of the faradic current were followed by a marked amelioration of these symptoms.

The limbs especially progressed rapidly, and after eight applications became quite strong, and were quite relieved of the anæsthesia. Some tenderness along the course of the spine still remained, with occasional tingling in the extremities, but not sufficient to occasion the same annoyance as before.

*Spinal irritation of several years' standing—Recovery under spinal galvanization and general faradization.*

CASE XIV.—Miss C., a patient of Dr. Gregory, was referred to us with evidences of irritation the whole length of the cord. Under six weeks of treatment by spinal galvanization and general faradization the patient markedly improved in all her symptoms.

The tender points along the spine mostly disappeared, and after the cessation of treatment she continued to improve until recovery was approximately complete.

The symptoms were of several years' standing.

*Spinal irritation of two years' standing—Recovery under spinal galvanization.*

CASE XV.—Miss S., an inmate of the New York State Woman's Hospital, was affected, in addition to uterine disease, with severe and persistent spinal irritation of over two years' standing

Spinal galvanization repeated a dozen times during the course of a month effectually overcame the excessive irritation of the cord, and resulted in greatly increased strength.

*Insomnia.*—Insomnia is a symptom which, with greater or less uniformity and severity, accompanies nearly all forms of disease.

It is a symptom of such an indefinite variety and complexity of pathological conditions that it is manifestly impossible to treat it with anything like uniform success by any one conceivable form of medication; but of all the remedies that have yet been tried there is, we believe, no one which permanently relieves the symptoms in so large a proportion of cases as electrization. The effects of electricity on the sleep, whether used in the form of general faradization, or galvanization of the head and cervical sympathetic, are both temporary and permanent. The *temporary* relief that appears the night or two following an application, though usually far less potent than those of bromide of potassium and hydrate of chloral, are yet very decided; but it is for the *permanent* relief that electrization is chiefly indicated in this symptom. This comes gradually, slowly, and as a result of the improvement of the morbid condition on which the insomnia depends.

As has been stated, improvement in sleep is one of the earliest effects for which we look during a course of treatment by general electrization. In a wide range of diseases sleep, to a certain extent and with exceptions, may be regarded as a thermometer of health. When all other bodily functions are well performed, the sleep is usually sound, calm, and refreshing; when it becomes painfully and persistently disturbed by dreams, or is long absent, we may suspect actual or approaching disease.

Temporary loss of sleep, that comes from temporary anxiety or from neuralgia or other pain, is usually relieved with the removal of the cause, and only demands special medical treatment when it is long continued.

The *treatment* of insomnia is really the treatment of all the diseases on which it depends. For those cases where simple wakefulness exists, unaccompanied by any other symptom of recognizable disease, we

may use either galvanization of the sympathetic or in the head, or faradization of the head and spine, or, better than all, general faradization for somnolence is a result of all these methods of electrization. It is not even necessary to make the applications to the head, the sympathetic, or even to the spine, in order to produce sleep. Simple peripheral galvanization or faradization will produce this result, and in some cases to a very marked degree. This must, we suppose, be explained by reflex action. In case of rheumatism of the hip-joint, which we once treated by galvanization through the joint, the soporific effect on the patient was so marked that he fell into a profound slumber before we had time to leave the house, in less than ten minutes after the application was over. In another case of infantile paralysis the mother reported that the child slept soundly for two hours or more after each sitting, although only the limbs were galvanized.

*Persistent insomnia after child-birth—An application of the faradic current to the head and spine is followed by sleep of several hours.*

CASE XVI.—Mrs. A., aged 30, of a highly nervous organization, gave birth to her first child after a labor of 16 hours. So great was the disorder of her nervous system, that for 5 days and nights she was unable to close her eyes in sleep. Her condition was most distressing, and resisted all efforts in the way of medication.

It was agreed that a mild application of the faradic current should be applied to the head and down the spine. The result was most decided and gratifying, since a sleep of several hours, deep and refreshing, immediately followed. It is proper to say that subsequent applications did not have the same decided effect, although they evidently strengthened the nervous system of the patient and greatly aided in dissipating the condition of insomnia.

*Insomnia of months' standing immediately relieved by general faradization.*

CASE XVII.—Mrs. C., a young married lady, was directed to us by Dr. J. Marion Sims, who was treating her for uterine difficulty. She was suffering acutely from insomnia, and it was hoped that some form of electrization might prove beneficial, more especially since she had previously been relieved by the application of electricity, although its administration had been without method. We subjected her to the most thorough form of general faradization, directing especial attention, however, to the head and neck. The applications were administered on five successive days, and during each of the following nights the patient enjoyed uninterrupted and refreshing sleep. As to the permanency of the effects we are not informed.

*Insomnia of several months' duration relieved under treatment by general faradization and galvanization of the brain.*

CASE XVIII.—Mr. J. D., aged 65, was referred to us by the late Dr. J. C. Nott for the relief of insomnia of such an obstinate character as to threaten serious consequences. He had suffered a few months previously from a severe attack of congestive chills. From the effects of these he had approximately recovered. His strength and

appetite were fair, but as it was sometimes impossible for him to sleep more than an hour or two during the whole night, he was fast merging into a nervous, excitable condition. The patient was treated by both general faradization and galvanization of the brain. He very gradually improved, and at the end of a month's treatment he was enjoying five and six hours' continuous sleep every night.

*Insomnia following menstruation—General faradization affords immediate relief.*

CASE XVIIIa.—Mrs. B., aged 40, suffered an unusual loss of blood at each menstrual period, which was followed by obstinate insomnia during the succeeding two weeks. General faradization was essayed for the relief of the sleeplessness, and was entirely successful. Three or four applications after each period was sufficient to promote calm repose until the next flow.

*Astraphobia* (αστραπη lightning and φοβος fear of).—Some individuals, especially those of peculiarly impressible organizations, are not only unpleasantly but seriously affected during thunder-storms that are attended by vivid flashes of lightning. They suffer not only distressing fear, but positive pain in the head or stomach, that leaves them in a condition of exhaustion that may last several hours, or even two or three days.

A medical friend informed us of a patient under his care, who during thunder-storms was attacked by severe nausea, and by convulsive attacks resembling epilepsy. Under treatment directed to the improvement of her general system she greatly improved. In some cases diarrhœa is excited.

These symptoms, though most frequent with nervous people, and especially with women, may also appear in those who are otherwise strong both in health and in will power.

In two cases of astraphobia of long standing we found much diminution of volitional contractility and considerable anæsthesia, but no loss of electric muscular contractility.

Treatment by the electric brush and central galvanization afforded much although not absolute relief.

## CHAPTER XVI.

### INSANITY.

WE have seen that very much has been accomplished in the treatment of hypochondriasis and melancholia by the combined methods of central galvanization and general faradization, and, reasoning from analogy, it is probable that an important future is in store for the scientific faithful use of these methods of electrization in our public and private asylums.

*It is not as well recognized as it should be that in diseases of the brain and spinal cord, where the mind is seriously affected, the electrical treatment is also indicated, just as in diseases of the same organs when the mind is not affected.* In some of the asylums of England, United States, and Germany, electricity is now and for some time has been used as an adjunct to other remedies for the treatment of different forms of insanity; but with a few exceptions, the treatment is not systematically carried out, and, partly through ignorance of the methods of application, partly through want of sufficient medical assistance to supervise the necessary details, the results have not been entirely satisfactory, and the cases have not been fully recorded.

We should except from these remarks the Alabama Asylum for the Insane, where, under the superintendence of Dr. Bryce, both currents of electricity have been used in the treatment of the patients for the past two or three years.

We have corresponded with Dr. Bryce on the subject from the first, and have at different times given suggestions in regard to the methods of application, which suggestions have been carried out so far as possible for the already overworked officers of that institution.

Under date of February 17th, 1873, he gives the general results of his observations in the following language: "We like it: find it beneficial in most cases, valuable in a majority, and indispensable in certain forms of hysterical insanity, in primary dementia, and neurasthenia."

The failures in this as in other branches of electro-therapeutics are, in fact, the logical result of want of familiarity with the management of



batteries, of incorrect ideas on the differential action of the currents, and the general action of electricity on the body, and deficient technical skill in the details of the applications.

For those who are beginning to use electricity, or are contemplating its use in the asylums for the insane, these general suggestions may be of service: 1. Let it be remembered always that electricity, in any form—Franklinic, Galvanic, or Faradic—when applied to the body, acts as a *stimulating tonic with a powerful sedative influence*. It is an agent for *improving nutrition* in any condition, local or general, where improvement in nutrition is required. It is to be used for the insane just as bromide of potassium, quinine, strychnine, and iron are used.

The order and degree of its effects depend largely on the method and manner of application, and on the constitution and disease of the patient to which the application is made.

2. That in insanity the brain is not the only part of the body affected. Excluding those cases of insanity produced by reflex action from the digestive and pelvic organs, there are very many cases where the spinal cord and other parts of the central and peripheral nervous system suffer as an effect of the disease of the brain.

While these remarks may seem but commonplace to experienced psychologists, and while the fact of the relation of diseases of the brain to diseases of other parts of the body is continually recognized, when other remedies are employed, still, in the application of electricity, some experimenters have acted on the theory that the *brain alone should be treated*. Those who act exclusively on this theory will not gain great victories over insanity by electricity. Some of the applications should be made in such a way as to bring the whole central nervous system under the influence of the current, and local diseases associated with insanity as a cause or effect should receive local treatment.

The central nervous system is best brought under the direct influence of the galvanic current by the method of central galvanization. The method may be varied by galvanization of the brain, cervical sympathetic, pneumogastric and spine; but the method of central galvanization is easier, safer, and more effective. In cases associated with debility, and especially in those forms of insanity dependent on neurasthenia or nervous exhaustion, general faradization answers a good purpose, and may with great advantage be used alternately with central galvanization or localized galvanization of the nerve centres.

3. The first tentative applications should be very mild, and the strength of the current and the time of sitting should be gradually increased as the patient proves himself able to bear the treatment.

In the following case, although no permanent relief was afforded by the method employed, the temporary effects were so sudden and startling as to render the history of exceeding interest :

*Acute mania of the most intense character existing four months—Remarkable effects of general faradization.*

CASE XIX.—Miss R., aged 20, living in Harlem, and a patient of Dr. Joseph Wooster, of New York, was suffering from acute mania dating from suppression of the menses, occurring four months before she fell under our care. She had always enjoyed most excellent health—indeed was remarkable for her vigorous, robust constitution, and it may be added, the ruddiness of her complexion. While watering the plants in the conservatory of her sister, her clothes became quite wet ; she neglected to change them immediately, and the consequence was a suppression of the menstrual flow. She complained on the following day of severe headache, and on occasions, during the next two weeks, was markedly unreasonable in her action and demands.

Finally active delirium set in, but with no decrease of bodily strength. At times she was intensely violent in her demonstrations—screaming at the top of her voice and breaking every article of furniture within her reach ; as a consequence she was confined in a room stripped of its furniture, and in her wildest moods the strait-jacket was applied. For more than two months no sleep visited her eyelids, without the nightly administration of from 100 to 120 grs. of chloral. During the morning she was often measurably quiet, but as evening approached she became absolutely ungovernable, and when chloral was not given she had been known to pace around the room with great rapidity and strength, muttering to herself, with absolutely no cessation, from sunset to sunrise. She had decreased in weight from 160 to 110 lbs. On the evening of the 15th of April, she was held firmly in position by several powerful assistants, and, after thoroughly moistening the hair of the head, we submitted her to the most thorough form of general faradization with the very smoothest current obtainable. The current was of great strength, but evidently in itself caused no discomfort to the patient. That night, and without the use of any drug, the patient enjoyed five hours of the quietest sleep, and for 48 hours thereafter was perfectly obedient and tractable. Another paroxysm of violence again showed itself, and the same form of application was readministered. She again slept quietly, and in the morning awoke perfectly rational, but extremely weak in body. The day being bright and sunny, a chair was placed in the yard, where she sat for several hours, and in all her conversation evinced entire freedom from anything like mental derangement. Suddenly, however, she arose from her chair and ran around the yard with great rapidity. She was immediately captured, and, when taken to her room, gave evidence of all her former derangement. She was unusually violent during the rest of the day, but after the administration of 100 grains of chloral (and this was effected with great difficulty, owing to her fierce struggles) she passed the latter part of the night in comparatively quiet sleep. On the following morning she awoke, somewhat excited, and remained so during the day, while towards evening she as usual became more violent.

General faradization was again tried, and was attended by its previous good effects. Four or five hours of quiet sleep followed, and on awakening, and for a part of the succeeding day, the patient was quite calm and in some respects entirely rational

Not to prolong this description, it may be said that neither general faradization nor

central galvanization seemed to be sufficient to accomplish more than is related in the above description, and finally it failed to give marked relief. The patient was taken by her friends to an asylum and passed from under our observation.

*Menopause insanity in a married lady—Great melancholy; constant weeping; attempts to commit suicide; attempts at starvation; loss of flesh; attacks of numbness; heaving, tearing, grasping, binding sensation in stomach and abdomen; unilateral sweating; hysterical attacks of crying, laughing, and unusual susceptibility to electricity—Gradual and steady recovery under central galvanization of the cervical sympathetic, combined with cod-liver oil emulsion.*

CASE XX.—Mrs. S., a married lady of middle life, was referred to us, October 19, 1871.

The patient was pretty evidently suffering from menopause mania, of several months' standing, and evinced no disposition to recover. She attributed all her symptoms to the use of the vaginal syringe, but there was no evidence of this, and the case was pretty clearly one of mania dependent on the beginning of the change of life.

The patient would *never sit down*: all day long she walked and walked the floor of the house, sometimes standing still a moment to look out of the window or converse or to look vacantly into space; but never would *sit for a moment* or even lie down on a lounge; at night only would she go to bed.

She would weep for hours together, and when not weeping was heavily depressed. Her ruling desire was to commit suicide, and most resolutely she tried to starve herself to death, but failed in the attempt for the reason that she could not resist the temptation to take a bite now and then, although she did not partake of a regular meal for several weeks. She was naturally very fleshy, and had lost fifty pounds in weight. She tried to get hold of the batteries that were left at her house in order to drink the acid solution, and her husband was obliged to take away the bottles after each application. The patient had besides many vague, nervous symptoms, such as numbness and tearing, rolling, heaving, burning, binding sensations in the stomach and abdomen. Attacks of unilateral swelling on the left side came on at times, and the left side in all respects was weaker than the right.

We suspected that all the symptoms might be more or less reflex from the uterus, but the patient would not yield to our suggestion that some gynæcologist be called in to make an examination.

There was tenderness over the ovarian region, especially on the left side, and also tenderness on the dorsal and lumbar vertebræ, and at times along the entire length of the spine.

It seemed probable that the patient would have to be sent to an asylum, but as her husband was so situated that he could give her close attention, we decided to first exhaust treatment by electricity and internal medication.

We used central galvanization varied by galvanization of the cervical sympathetic and spine, and prescribed for internal use the cod-liver oil emulsion. She was found to be very susceptible to electricity: only gentle currents and short applications were borne, and when thus used the sedative effect was excellent; but when carried beyond a certain point irritation rather than sedation followed. The applications were made on the average about three times a week, for four months, with at first slow and almost imperceptible, and afterwards with rapid improvement, and with ultimate and

permanent recovery. A year and more after the treatment was abandoned, the patient had fully regained and still retains all her flesh, health and spirits.

The above case seems to us to illustrate the following points :

1. The well known fact of the curability of menopause insanity, even when the symptoms are of the worst character. In the case of Mrs. S. all the symptoms were bad symptoms. At times her maniacal attacks were so violent as to be absolutely alarming, and twice at least we had reason to be considerably terrified.

2. The advantage of combining medical treatment with various methods of electrization. Although the patient herself and her husband attributed the result to the electrical treatment alone, yet in our own judgment the credit should be divided between the medical and the electrical treatment, and the element of time should also be considered. The patience and perseverance of the husband and his constant attention should be considered.

3. The fact that electricity, cautiously used, may be of great service even when it is not well borne. Mrs. S. never could endure a long or strong application, even when she had been long under treatment, and by some the case might have been given up as not adapted for electrical treatment.

4. The principle that, in the treatment of insanity by electricity, the applications should not be confined to the brain, but should be made so as to affect the whole central nervous system, which, primarily or secondarily, must be more or less involved in nearly all phases of insanity.

## CHAPTER XVII.

### CEREBRAL AND SPINAL CONGESTION.

AN exceedingly interesting point in the consideration of congestion of the nerve-centres is, the discrepancy between the observed symptoms and the authoritative statements, in regard to the necessary and constant relation of certain symptoms with that condition. In pathological conditions of the brain and spinal cord, more perhaps than with other organs of the body, it is difficult, nay, utterly impossible, to associate a long list of distinct symptoms with some change or tendency to change of structure, and say that they invariably exist as effects and cause. What we term distinct variations from the physiological conditions of the great nerve-centres, so markedly and undeniably run into and overlap each other, are so frequently as it were intertwined, that it is hard for the most careful observer to do more than to arrive at approximately correct conclusions as to the actual pathology. Irritation and congestion of the cord may coexist. Congestion of a severe and chronic character may simulate actual sclerosis, and hysteria associated with a mild form of either irritation or congestion may give rise to symptoms of anæsthesia and such decided impairment of electro-muscular sensibility as to completely mislead the practitioner and suggest the existence of serious organic disturbance.

These remarks will be more fully appreciated by referring to several of the illustrative cases that follow.

*Prognosis and Treatment.*—The relief that is afforded by electrization in the ordinary forms of passive spinal and cerebral congestion is quite constant and reliable.

Galvanization of the brain, spinal cord, and sympathetic are of course to be used and should be attempted with more or less thoroughness according to the indications of each individual case.

General faradization, however, should not be neglected. There are very few cases that will not receive benefit by its judicious employment.

*Sudden onset of congestion of the cord associated with symptoms of irritation—Rapid recovery follows general faradisation.*

CASE XXI.—Mr. B. W., a youth aged 17, but exceptionally mature, both in physical and mental endowments, was referred to us by his physician, Dr. John J. Crane.

This patient, who was a student at Harvard, stated that some weeks previously he had one afternoon walked quite briskly, and for a considerable length of time, and while in a state of partial perspiration had reclined upon the grass until a sense of chilliness warned him of his imprudence. During the rest of the day, and on retiring at night, he observed no unusual symptom, but in the morning the legs were found to be stiff and weak, associated with a decided loss of co-ordinating power. In short the patient was suffering from incomplete paralysis in a paraplegic form. There was slight but marked tenderness along the spine on pressure, but no exaggeration of reflex excitability in the limbs, and no appreciable impairment of electro-muscular contractility or sensibility. Anæsthesia was quite marked in the calves of the legs and toes, but any sensation of tingling was altogether wanting. Pains in the back and limbs were not increased by motion, but the patient complained of some discomfort along the spine that was increased at night by the warmth of the bed. It seemed sufficiently clear that the case was one of spinal congestion, and our first thought was to trust to galvanization of the spine, but on further thought, and taking into consideration the recentness of the attack, and the remarkable effects of general faradization in equalizing the circulation, we submitted the patient to a most thorough but mild *séance* of the last-named method, and directed him to call again in the course of a couple of days. On his return we found that the anæsthesia had almost entirely ceased to annoy him; his limbs were more supple and stronger, and there was a manifest increase in the power of co-ordination. Substantially the same method was employed on seven different occasions from May 5th to May 13th, when he returned to his studies completely recovered.

In the case above cited, anæsthesia was a prominent symptom, while there were absolutely no sensations of formication or tingling.

Tenderness on pressure along the spine was decided, and yet we find various authors stating that in spinal congestion not only is this symptom wanting, but so also is anæsthesia, while the sensations of formication and tingling in either the toes or fingers are almost invariably present.

Sometimes the symptoms of one pathological condition may be the more prominent—sometimes the symptoms of another—and occasionally it may be observed by one whose experience is at all extended that spinal congestion and irritation occur together as affections, so to speak, co-ordinate and coequal. In this case congestion of the cord was undoubtedly the predominant condition, while the symptom of tenderness along the spine on pressure rendered it evident that irritation was present as well.

*Spinal tenderness along the lower portion of the spine on pressure followed by pain in the bowels and extremities—Impaired motor power, etc.—Improvement under spinal galvanization after failure of general faradization.*

CASE XXII.—As an illustration of a very considerable loss of power in the lower limbs from well-marked spinal congestion, we refer to the case of a married lady aged 35, who was placed under our care by Dr. J. O. Farrington. Some four years previously she first began to notice certain symptoms for which she could not account, but which evidently indicated some disturbance of the circulation, and possibly some slight spinal irritation.

She was then regarded as hysterical, and was really tormented with many of those vague and various symptoms which accompany this condition. Associated with her general nervous distress at that time, however, were a number of special symptoms, which she readily called to mind on being closely questioned. The most prominent of these was a sensation of tenderness when by any accident or design pressure was made over the lower part of the spinal cord. She recollected also that this sensation of tenderness was accompanied by pain in the lower part of the bowels and in the extremities, and frequently a disposition to nausea.

These symptoms became neither much aggravated nor decidedly improved, but continued to annoy her until about five months before she came under our observation, when a great change for the worse manifested itself.

Quite suddenly she found that the power of locomotion was considerably impaired. Slight exercise fatigued her more and more, until finally she was unable to walk more than a few hundred feet without becoming excessively fatigued. There was a sense of heaviness in the knees and feet, and frequently it required all her efforts to overcome this feeling of helplessness and move around. There was no anæsthesia; but she complained of a constant tingling in the fingers and toes.

Pressure, when made over any portion of the spine, caused no feeling of tenderness; but at night the warmth of the bed frequently produced a dull aching of the cord, which effectually prevented sleep. Both night and day she was annoyed at intervals with paroxysms of shortness of breath.

Hoping to equalize the circulation, and thus help to relieve the congestion which was supposed to exist, we made use of the faradic current. We could accomplish nothing with it, and resorted to the galvanic current, placing the negative electrode at the coccyx and passing the positive up and down the spine—spinal-cord current. The application was administered every other day, and was followed by good results. The sensation of tingling of which she complained was entirely dissipated.

The annoying shortness of breath was so much relieved that it was only occasionally and at night that she was troubled by it. Her feet became permanently warmer, and she was able to increase somewhat her amount of exercise without suffering fatigue. These results were accomplished in two months, during which time thirty applications of the galvanic current were made.

The prominent symptom which pointed to spinal irritation as the original difficulty in the case of this patient was the sensitiveness of the spine to pressure, and the accompanying nausea and pains.

The symptoms which indicated the later stages of congestion were :

First—Incomplete paralysis in a paraplegic form.

Second—A constant tingling in the toes and fingers.

Third—A dull aching along the spine, caused by warmth.

Fourth—Shortness of breath.

These symptoms, together with the absence of some of the prominent indications of myelitis, viz., anæsthesia, paralysis of the bladder and sphincter ani, impairment of electro-tractility and electro-sensibility, and also of tenderness on pressure along the spine, which does not accompany the graver diseases of the cord when not associated with spinal irritation—all these fully confirmed the diagnosis of congestion of the cord.

*Cerebral congestion in a young girl—Attacks brought on when working on a sewing-machine—Great temporary relief under central galvanization, galvanization of the sympathetic, and bromide of potassium—Relapse under the continuation of the exciting cause.*

CASE XXIII.—E. A —, a girl twenty-four years of age, came to us representing that for four months she had suffered from attacks of fulness of the head, flashing of the face, with burning feeling that came on, sometimes every day, especially in the afternoon and evening, when she had been hard at work on the sewing-machine. She was employed in a shop where she was expected to work all day on the machine. The constitution of the patient was excellent, and there were no evidences of uterine disorder.

We used central galvanization, galvanization of the head and sympathetic, and prescribed bromide of potassium internally, with immediate and decided relief, but the symptoms recurred when she returned to hard work on the machine.

*Cerebral congestion and exhaustion induced by over-toil and worry, following cure of catarrh and nasal polypi—Terrible insomnia—Temporary numbness—Recovery under galvanization of brain and cervical sympathetic, and internal use of cod-liver oil emulsion.*

CASE XXIV.—Mr. D —, a gentleman of middle life, a political editorial writer on one of our prominent Western newspapers, consulted us December 20, 1872, for persistent insomnia of a very aggravated character, that for one year had forced him to try all methods of treatment, including hydropathy, homœopathy, severe exercise, etc., with but little profit. The condition had come upon him as a result of over-toil in his profession, combined with mental annoyances of a most serious character. Formerly the patient had suffered from nasal catarrh (chronic rhinitis) and nasal polypi: *as the cerebral disorder came on, the catarrhal symptoms disappeared.*

The insomnia had been most obstinate: for weeks and months it had been necessary to use chloral, else there was absolutely no sleep; and recently the chloral had lost somewhat of its power.

We gave him a few applications of electricity, using the ordinary methods of galvanizing the brain and cervical sympathetic, and gave the cod-liver oil emulsion. He was obliged to return to his duties; but he carried out the treatment faithfully, and now and then reported his progress. The improvement was constant and permanent. He got along with less and less chloral. In the course of a few weeks he wrote that he was nearly well; but he adds: "The catarrh is coming back; the devil take it!"



## CHAPTER XVIII.

### NEURALGIA.

THE relief of pain, whether of a pseudo-neuralgic or hysterical character, or whether dependent on true neuralgia or other causes, is a very important function of electrization; but in no condition has it been more difficult to discriminate correctly in the selection of the proper method of electrical treatment. True neuralgia, as defined by Anstie, is without doubt most successfully treated by galvanism, while hysterical neuralgia, and the so-called pseudo-neuralgia, which are simply forms of pain, occupying certain areas, and running seemingly in the direction of certain nerves, yield most readily to faradism.

More specifically, the effects of *pressure* in the various forms of neuralgia are exceedingly useful, as guiding symptoms, indicating the proper current. We do not by any means lay it down as a universal law, but it will certainly be found that, in the great majority of cases of neuralgia, where firm pressure over the affected nerve aggravates the pain, the galvanic current is indicated, while the faradic current has the greater power to relieve when such pressure does not cause an increase of pain.

In the class of cases called sometimes hysterical hyperæsthesia, it is well known that firm and prolonged pressure affords marked relief, while pressure superficially applied increases the distress. The faradic current is here infinitely superior to the galvanic.

*Electro-diagnosis* in neuralgia discovers the painful spots that are detected by pressure in the course of the affected nerve, and may also discover sensitive points on the spine, or the head, that might, perhaps, have otherwise escaped observation.

*Treatment.*—Before attempting the electric treatment of neuralgia, we should endeavor to diagnose its general character, in order to decide upon the method to be employed. In doubtful cases it is necessary to try in succession central, peripheral, and general treatment.

The treatment of the different varieties of neuralgia is the best test of skill in electro-therapeutics. There is no disease or symptom in which the results of treatment in different cases so closely depend on

the nature and strength of the current used, and the method and frequency of the applications.

Cases that injudicious treatment might aggravate may, by the exercise of the skill and caution that experience teach, be rapidly cured.

The success achieved by electrization in the treatment of neuralgia has been brilliant and remarkable, and would be sufficient of itself to entitle it to a prominent and indispensable position among modern remedies. What is more remarkable still, is that this success has been achieved by very diverse methods of applications, and with imperfect, indifferent, or incorrect diagnoses. All forms of electricity—statical, galvanic, and faradic—in all the different methods and phases of electrization, general and localized, centrally and peripherally, by currents, stable, labile, continuous, interrupted, uniform, and increasing.

The pain is frequently relieved in the midst of the application; but in such cases it usually returns in the course of a few hours, and sometimes with heightened intensity. Some cases of a peripheral character are permanently dispelled by one or two applications.

Electricity is applied for neuralgia in the following forms:—

*General faradization and central galvanization.*

*Localized faradization or galvanization, central or peripheral, or both combined.*

*Galvanization of the cervical sympathetic.*

*Electric brush.*

*Electric moxa.*

*Statical electricity.*

*Electric bands and disks.*

*The magnet.*

Statical electricity works well in neuralgia, and excellent cures have been performed by it, but there is no evidence as yet that it is in any respect superior to the galvanic current when rightly used.

*Many of the failures and disappointments with the use of electricity in neuralgia have been due to the mistake of treating constitutional diseases locally, and the central varieties peripherally.*

There is one difficulty in the treatment of neuralgia by electrization, and that is that, on account of the intensity of the pain of the disease, patients are sometimes unwilling to give the treatment a fair trial. This difficulty is further increased by the fact that, during or after the first two or three applications, the pain may be *temporarily aggravated*, especially if the sittings have been long, or with currents of too great strength. For this reason the initial applications should be made with

caution, and the operator should not yield to the temptation to renew them too frequently. Once a day, or every other day, is about as often as applications can be made with benefit.

As before remarked, the methods of applying electricity must be studiously adapted and varied to each case, ever *keeping in mind that all methods of using electricity have been successful in this disease, and that no one method is uniformly successful even in the same variety.*

Besides the central and general electrization, which is to be conducted on general principles, in order to affect the seat of the *disease*, all the varieties of neuralgia may demand more or less treatment in the seat of the *pain*. For this purpose we may use either faradic or galvanic currents. Although the faradic achieves excellent results, yet some of the most striking results have been obtained by the galvanic. It sometimes relieves the pain when the faradic only aggravates it.\* After the faradic current has been tried a few times without effect, we should never abandon the case without resorting to the galvanic, or the two currents may be used alternately. As a rule, the applications should be short and made with a mild current; but this rule has marked exceptions. There appears to be no special law in regard to the direction of the current. The strong statements that have been made in regard to the superiority of one or the other pole in this disease are not sustained by experience. Either the positive or the negative pole may be placed over the painful points, while the other pole is applied near or on the nerve centre. Thus, in neuralgia of the arms, one pole may be placed at the cilio-spinal centre, and in neuralgia of the legs, on the lumbar vertebræ, and the other on the affected nerve (spinal-cord-nerve current).

The *electric moxa* is sometimes more rapidly efficacious in neuralgia than any other method of treatment. It is, however, a very painful procedure, and many patients will not bear it.

It seems to act partly as a counter-irritant. Meyer very strongly advocates the use of electric moxa in neuralgia, and sustains his position by a number of cases. Very few American patients in the higher walks of life will bear this severe method of using electricity.

*General Prognosis.*—Take the cases as they arise, without reference to their pathology, duration, or situation, neuralgia offers a very favorable prognosis. The majority of cases will be cured or permanently

\* The statements of Niemeyer and others that the faradic current never succeeds in neuralgia after the galvanic fails, is not true. We have seen several cases where relief was obtained by faradization with Kidder's continuous machine, after galvanization had at least apparently failed.

improved. Patients who have the neuralgic constitution are liable to relapse in time, however successful the treatment may have been.

*Paroxysmal attacks of a most distressing general neuralgia, associated with menorrhagia and anæsthesia, treated by general faradization—Recovery.*

CASE XXV.—A lady about 30, married, but childless, had suffered from several miscarriages, and had been treated for a long time for ulceration of the neck of the uterus that finally yielded to local applications. Up to her twenty-fifth year she had enjoyed a good degree of health; but after her first miscarriage she began to suffer from prolonged menstruation, attended with an excessive flow. This condition had existed but a few months when the patient began to experience certain wandering pains over the body, that became more marked at each return of the catamenia, until the paroxysms assumed a most distressing character. They were usually ushered in by tenderness and a sensation of oppression in the epigastric region. Throughout the whole attack the most acute pain would be felt over the stomach, and was attended by vomiting. Most of the body was, however, to a greater or less extent, affected by the disorder. The head became tender to the touch, the eyes intolerant to light, and the tongue and mucous surfaces of the cheek would be affected by a very annoying sensation of numbness. Several times a year she was prostrated by symptoms that were very sudden in their onset, and exceedingly alarming in character. The pulse, almost without warning, would fall to 40 or 45 in the minute, and become so feeble as to be hardly perceptible. The power of articulation left her, the anæsthesia of the mouth and tongue became complete, and her face assumed a deadly color and coldness. These attacks lasted from twenty minutes to half an hour, and were treated by the free use of brandy and carb. of ammonia. An application of general faradization, given one evening during one of her periodical monthly paroxysms, so relieved the distress that a quiet night was the result. It may be here stated that it was impossible for the patient to take opium in any form with benefit. Exceedingly small doses caused sleeplessness and the most intense excitement. Invariably after this we found that a similar application would greatly alleviate the pain. The main idea, however, was to strengthen the general system, and so prevent these attacks. For this purpose, on every other day she was treated thoroughly by general faradization, and it was not long before its good effects were manifest. In the course of a few weeks her powers of endurance had increased considerably; and when the menses appeared they were of shorter duration, and attended with a much less loss of blood than before. The neuralgic pains were incomparably less severe, and she rallied to her usual condition immediately. After remaining under treatment several months she was discharged as cured. Five years have elapsed since treatment was discontinued, but she has never suffered since from those occasional attacks of which mention was made. Her menses continue regular and normal; and it is only after great provocation that she ever experiences paroxysms like those of former days.

*Intercostal neuralgia of a malarial origin—Recovery under general faradisation and quinine.*

CASE XXVI.—A young man, who had been exposed to the hardships and dangers of a frontier life, was suffering from distressing pains that were confined mainly to the thoracic region on either side. Several months before we saw him, he was prostrated

by an attack of **intermittent fever that recurred several times after being apparently subdued.**

One of the paroxysms was followed by what his attendant called "*brow ague*"—a term not unfamiliar some years ago to the residents of malarial districts.

It was characterized by sharp shooting pains all over the head and face, affecting, however, especially the forehead and eyes. The neuralgic symptoms soon abandoned these parts, but in a few days manifested themselves by an unusually severe paroxysm in the chest and side. For a number of months before he fell under our notice, attacks of intercostal neuralgia occurred at intervals of two or three days.

The patient experienced no distinct chills or marked febrile excitement, but the neuralgia was almost invariably ushered in by a creeping sensation of cold down the back and limbs. The exciting cause was undoubtedly a malarial poison. The diagnosis of neuralgia was unmistakably confirmed by the presence of that almost pathognomonic symptom, namely, pain on pressure over the spinous process of one of the last dorsal vertebræ. A gradual improvement took place under frequent general applications of the faradic current. Quinine was administered at the same time, so that we cannot state in positive terms the exact amount of credit due electrization. It must be remembered, however, that quinine had been taken for some time previously, and was followed by no very marked results. The first application, administered during a paroxysm of ordinary severity, was followed by a very grateful amelioration of the pain, and in all subsequent attacks the same result followed.

Ten applications served to break the periodicity of the attacks, and to place him on a plane so little below the normal, that it could be fairly said of him that he was approximately cured.

*Intercostal neuralgia, resulting from exposure to camp life—Spinal Irritation—Debility—Rapid improvement and recovery under general faradization.*

CASE XXVII.—L. C., aged 28, served in a Nevada regiment for three years during the war. After his discharge, in the fall of 1865, he was taken with acute articular rheumatism, which confined him to a hospital during the whole winter. The spring found him much better, and in a few months there seemed to be no vestige of the rheumatism remaining. His health remained delicate. In July, 1866, he was taken with severe pains in the back and side. He was treated by localized faradization a few times, but with no appreciable benefit. The neuralgia increased in severity, locating itself between the ribs. In January, 1867, he applied to us for treatment. He was then extremely weak, and presented a remarkably anæmic appearance. There was very great hyperæsthesia over the peripheral expansion of the affected nerves. Slight irritation by the finger-nail, or moderate pressure by the hand, was sufficient to cause considerable pain. On account of his extreme sensibility he was obliged to substitute for the coarse red flannel which he had been accustomed to wear, an undershirt of finer texture. Pressure made upon the first spinous processes of the dorsal vertebræ caused no uneasiness, but when the sixth and seventh processes were firmly pressed, the patient loudly complained. We gave him a general application, as is our custom in such cases. The whole system was brought powerfully under the influence of the faradic current. The application at once relieved him, and in three days he was directed to come again. During that time he suffered much less than usual; his appetite had improved, and for the first thirty-six hours he was much invigorated. He

visited us for one month, during which time he received ten general applications. The improvement was uninterrupted from the beginning.

After the fourth application he suffered no more from the neuralgia. The color returned to his cheek; his appetite became more vigorous from week to week, and when he discontinued treatment, we regarded him as comparatively well.

This case called for a powerful constitutional tonic. Hardships in the army and previous disease had reduced his stock of vitality to such a degree that our ordinary internal tonics failed to produce their accustomed results. His nervous system had been so shaken, and all his functions so disturbed, that he could not assimilate the iron and bitters that were so much needed. It is in such cases that general faradization achieves most satisfactory results.

*Central Neuralgia.*—Under this head we include those cases of neuralgic pain that certainly depend on pathological lesions of the central nervous system.

The neuralgic pains of locomotor ataxia belong to this class. Those who with Dr. Anstie regard neuralgia as a distinct disease, dependent on atrophy of the roots of the nerves, do not regard these pains as really neuralgic. Under this class also come certain varieties of headache and cervical neuralgia.

*Cephalalgia (Headache).*—Headache should be treated by general or localized electrization, according to the indications of each case. Dry faradization with the hand is used successfully. Stable galvanization or faradization, uniform or increasing, may be employed. Labile applications with the moistened hand are sometimes of service. General faradization is more effective than localized, for the reason that in so large a proportion of cases the pain in the head is so very frequently symptomatic of disease of other parts of the body, the precise nature and locality of which we cannot possibly detect. Central galvanization is sometimes more efficacious than any other method. Relief not unfrequently follows galvanization or faradization of the stomach, or bowels, or spine, or galvanization of the sympathetic, even when the head is not touched. *Applications to the back of the neck are sometimes more efficacious than direct applications to the head.*

*Prognosis.*—Although headache in this country is even a more frequent symptom than dyspepsia, yet patients do not usually apply for treatment for this symptom alone, but only when it is associated with more special and distinct affections. The immediate effects of electrization in headache are as variable as the pathology of the symptoms. It sometimes relieves, sometimes aggravates, and sometimes gives only negative results. Sometimes the pain is relieved in the midst of the

sitting; more frequently the relief does not appear for several hours. There is no reason to be discouraged because immediate relief is not obtained. In very many of our cases of dyspepsia, of anæmia, chlorosis, nervous exhaustion, paralysis, headache is a more or less constant symptom, from which during the treatment they usually obtain either relief or cure. In rare cases all other symptoms yield but this.

In many of the cases of dyspepsia, neurasthenia, anæmia, and hysteria, headache was a prominent symptom, which was not only temporarily but permanently relieved by the treatment. If we were to judge from our own observations, electrical treatment is even more efficacious to *prevent* attacks of headache, by improving the tone of the system, than to dissipate the pain after it has once set in.

*The Magnet.*—The therapeutical results that have been obtained by the magnet in the treatment of headache are not sufficiently encouraging to entitle it to special notice. Something has been claimed for it, but, as a rule, it has been found that it is necessary that the patient should be of a peculiarly impressible organization, in order to be in the slightest degree affected by it.\*

*Frequent and severe headaches in a girl of fifteen since the age of four—Approximate recovery under a month of central galvanization—Subsequent relapse.*

CASE XXVIII.—Miss C., aged 15, consulted us at the suggestion of her physician, Dr. Everett Herrick. The patient was small of her age and menstruated first at the age of eleven. In regard to hereditary influences it may be said that her father had for many years suffered from periodical attacks of headache, and that her aunts, *sisters* of her father, had also menstruated at about the same early age as the patient herself. The following were the symptoms for which relief was sought: Since the age of four she had suffered intensely from headaches associated with vomiting, which latterly had increased in frequency until four out of the seven days of the week was the ordinary ratio of the sick days to the well days. It may be remarked, however, that at no time was she entirely free from pain. The general health and strength of the patient was fair; but the circulation was feeble and the appetite not very good. Central treatment being indicated, we began the use of this method by the application of the galvanic current from four ordinary zinc-carbon cells, and during the treatment, consisting of seventeen sésances, and extending from May 10th to June 16th, we gradually increased the number of cells to eight. It was observed that the attacks greatly decreased in frequency and severity, and when she left the city for the annual summer vacation she was but little annoyed by her old enemy. We learned incidentally that subsequently the patient relapsed.

\* Tripiér (Annales de l'Electrothérapie, 1863) presents a résumé of some not very convincing experiments of l'Abbé Le Noble in the treatment by the magnet of headache and other nervous affections. The experiments were recorded by Andry and Thouvet, in "Mémoire sur le Magnétisme Médical." Paris, 1782.

*Intense and deep-seated cephalalgia—Permanent relief follows central galvanization.*

CASE XXIX.—A patient from whom a large fibrous tumor of the uterus had been removed several months before she fell under our observation, complained of such constant and severe neuralgic pains, which seemed seated in the centre of the brain, that at times she almost lost control of herself both physically and mentally. Neuralgia had been a symptom from which she had suffered more or less for years, but far less acute in degree than after the operation mentioned. From March 12th to 30th, 1872, central galvanization was applied on five occasions and with excellent results. The pains, although not entirely dissipated, became far less distressing in character, and ceased altogether to exert any mental influence.

*Throat dysæsthesia, associated with severe cephalalgia of twenty years' standing—Decided relief under central galvanization.*

CASE XXX.—Mrs. T., who was directed to us by Dr. C. R. Agnew, had for 20 years suffered from an almost constant and painful heaviness about the head and eyelids. Associated with this symptom were frequent periodical attacks of the most intense cephalalgia. For the last few years the patient had complained of a local neuralgia of somewhat rare occurrence, noticed by Hanfield Jones as "throat dysæsthesia." Dysphagia was present, with a sense of impending suffocation, with heat and dryness. Inspection revealed no inflammation sufficient to account for the distress.

The treatment consisted of some 25 applications, almost wholly by the method of central galvanization, and with most decidedly beneficial results. The heaviness of the head and eyes was much relieved, and the cephalalgia occurred at far greater intervals and with less severity.

The throat difficulty yielded more readily and completely than the other symptoms.

It was a noticeable fact in the history of the treatment of the above case that at the outset a mild current of say from five cells, when applied to the eyes, while it was not unpleasant and produced no aggravation of pain, signally failed to relieve.

A current from three cells was invariably followed by immediate alleviation of pain.

*Persistent and constant cephalalgia of long standing—Anæsthesia of head—No relief.*

CASE XXXI.—Mr. R., a clerk aged 22, was referred to us, April 22, 1869, by Dr. Hallet, of Brooklyn. The young man had been many months a sufferer from persistent pain through the head, in all parts of it, even to the back of the neck. Treatment had been of no avail. His constitution was of the nervous variety, and his symptom was aggravated by his sedentary mode of life, and by any sustained mental effort.

*Electric examination* with both galvanic and faradic currents demonstrated a very unusual lack of sensitiveness to the current on all parts of the head, which in health can bear only very gentle currents. All the modifications of electrization were em-



played for four weeks, without making the feeblest impression on the symptoms. No temporary relief could be obtained either during or after the séance. The most unusual fact of all was, that the pain could not be temporarily aggravated or changed in its character, even by powerful and somewhat prolonged galvanization. The failure was complete; after four weeks' treatment the patient was dismissed, no better and no worse than at the outset of the treatment.

The patient a few years subsequently committed suicide, being driven to the desperate act by constant and unrelieved pain.

A careful post-mortem examination made by Dr. A. B. Crosby, in the presence of Drs. E. S. Bunker, S. G. Armor and ourselves, revealed no pathological lesion that would satisfactorily account for the symptoms during life.

*Sick-headache (Migraine).*—The results of our treatment of sick-headache by electricity have not been quite consistent. In some cases the relief has immediately followed treatment; in other cases some time after treatment; in still other cases there has been no relief, temporary or permanent.

*Sick-headache—Vomiting—No relief from faradization.*

CASE XXXII.—In the case of a young lady, the onset of the pain is very peculiar. Without the slightest warning, when at church or walking, at the piano or engaged in household duties, her vision will become blurred. Objects before her seem to dance about in every direction, and she is unable to recognize familiar faces. No barometer is so accurate in indicating storms as are these nervous symptoms in foretelling the commotion about to take place in her system. Soon the blur before the eyes partially disappears, and a most raging headache sets in. The arteries in the temples swell, and pulsate with great rapidity and force. Sharp lancinating pains dart all over the head and through the eyes. As a rule, vomiting of a grumous-looking liquid, mixed with bile, accompanies the other symptoms. After lasting from 12 to 24 hours, the severity of the attack abates, leaving her in a somewhat debilitated state, from which she soon recovers. Electrization failed to give any relief. Bromide of potassium is the only remedy that has any effect whatever. Given in doses of 20 grs, as soon as the eyes become blurred, it will frequently lessen the severity of the pain in the head.

In the case of a sister of the above the headache is preceded by no blurring of the eyes, but is accompanied by an excessive and distressing sense of *nervousness*, causing the patient to throw her limbs and body about, and to "feel," to use her own expression, "as if she would fly." A number of applications of the faradic current enabled her to overcome this feeling of nervousness, and thus relieved her of one very annoying symptom of her disorder. Generally, though not always, in the cases just related, these attacks of sick-headache occur just before or during the menstrual period, and so would seem to be influenced in some measure by this function.

The true principle of treatment is to tone up the system by a persevering use of general faradization and central galvanization, with other

tonics, so that the paroxysms may be less frequent and less severe ; in other words, to combat the *nervous diathesis* of which the sick-headache is but a symptom.

The following case illustrates the advantage of carrying out this principle of treatment.

*Migraine of several years' standing in a lady of a very nervous temperament—Very great and permanent improvement under central galvanization.*

CASE XXXIII.—Mrs. K., a young married lady, daughter of a physician, was of a specially nervous organization by inheritance, and had suffered from neurasthenia, spinal irritation, and especially from frequent attacks of migraine. We treated her during the intervals of her attacks for twelve times by central galvanization. There was immediate improvement ; the attacks became less frequent and less severe. The improvement advanced after treatment was discontinued, until she was almost entirely free from migraine.

FACIAL NEURALGIA—(EPILEPTIFORM NEURALGIA—FOTHERGILL'S DISEASE—TIC DOULOUREUX).

Facial neuralgia appears under two forms. The mild form is usually of a peripheral character, being caused by neuritis, pressure from effusion, or decayed teeth. This form usually yields readily and surely to electrization. The severe form, to which Trousseau has given the name epileptiform neuralgia, is probably of a central character, being caused by a variety of pathological conditions of the brain.

The symptoms of this form of facial neuralgia are the spasmodical and very intense character of the pain in the course of some of the branches of the fifth pair. The spasms are of very short duration—ten to fifty or sixty seconds—and may be accompanied by convulsive action of the muscles. The attack may be brought on by any exercise of the jaws, as chewing, reading, eating, or talking. The pain is so great as to cause the patient to slap his face, or frantically rub the spot over the seat of the pain. Sometimes patients who have great self-control stamp violently on the floor, jump up if they chance to be sitting, pace the room, and utter piercing cries.

This terrible disease has usually been regarded as almost incurable, and is so pronounced by Trousseau, who has graphically described its symptoms.\* Section of the nerve, of which so much was once expected, is now but seldom used, and permanently succeeds only in exceptional cases.

By a judicious and varied use of peripheral faradization or galvaniza-

\* See his Lectures, Bazire's Translation, part I, p. 105.

tion, or by the electric moxa, or by galvanization of the brain or cervical sympathetic, a certain portion of these terrible cases can be relieved or cured. Our experience does not yet enable us to say what proportion the failures will bear to the successes; but if one case out of ten can be relieved or cured, it is justifiable to try electricity in all, since most other modes of treatment offer no hope.

We present typical examples of both failure and success in the electrical treatment of this disease.

*Epileptiform neuralgia of left side of face, of two years' standing, treated without benefit by various methods of electrization.*

CASE XXXIV.—Mr. P., aged —, was sent to us, November, 1869, by Dr. Willard Parker, with typical symptoms of epileptiform neuralgia. The patient, though a man of mild temperament, stamped furiously on the floor, even while telling us his history. The spasms of pain appeared in one spot, in the course of the lower branch of the trifacial. The general health of the patient was not greatly impaired, although he had suffered for two years.

We tried, in succession, all means of electrical treatment, with both currents. At one time some temporary benefit appeared to have been derived; it was, however, of short duration, and the paroxysms returned in full force.

After ten applications the patient abandoned treatment, utterly disheartened.

In the above case we made the applications twice a day, as the patient could stay but a short time in town. It is possible that better results would have followed if a longer interval had been allowed.

We now turn to the pleasanter side of the picture.

*Epileptiform neuralgia of two years' standing—Improvement under localized faradization; temporary aggravation by galvanization.*

CASE XXXV.—Mr. M., aged 65, of extraordinary vigor of constitution and perfectly temperate in every habit, stated that some two years since, in the year 1865, he first noticed a slight pricking sensation under the lobe of the left ear.

For one year this feeling occurred only occasionally, and annoyed him but little. At the expiration of this time the attacks became more frequent, were considerably prolonged, and produced actual pain.

It was a singular feature associated with his condition, that exposure to the sun's rays for a few moments would invariably occasion an attack of pain. About this time the loss of a large amount of money was a cause to him of great anxiety of mind, and evidently aided in aggravating his disorder. The paroxysms of pain increased in frequency and severity, until it was his sorrow to suffer the greater part of every day from the excruciating torture of the worst form of facial neuralgia. At night he suffered but little, but with the rising of the sun his distress began. The instant he opened his mouth to speak, darting pains would shoot over every portion of his face, followed by a profuse flow of saliva.

The act of eating was attended with even greater suffering, and frequently he would continue hungry for hours rather than make the attempt.

For two years he suffered in this manner, without being able to obtain more than slight temporary relief. Upon applying to us we immediately localized an exceedingly mild and fine faradic current through the different ramifications of the fifth pair, with immediate beneficial effect. The pain from which he was then suffering was subdued, and during the two succeeding days paroxysms of pain were much less readily excited than usual. A second application resulted in still further improvement; but at the third visit, hoping to accelerate the cure, we made use of a mild galvanic current from six of Bunsen's cells.

The effect was most disastrous. The neuralgic attacks returned with more than ordinary severity, and gave the patient no rest until we saw him again the next day. An application of the faradic current again relieved the pain as effectually as before.

From this time onward, under the exclusive use of the faradic current, the improvement was uninterrupted, until, after remaining under treatment six weeks, and receiving eighteen applications, he was discharged approximately cured. Occasionally, after a long conversation, he feels something like a twinge of the old pain, but it is so slight as to give him little annoyance.

*Neuralgia of the superior maxillary and ophthalmic branches of the fifth pair, followed by strabismus convergent and projection of the eyeballs—Treatment by localized faradization—Recovery.*

CASE XXXVI.—In September, 1867, the following quite novel case fell under our observation. The patient was a married lady (aged 35), who stated that in July, 1866, she was taken suddenly, during the night, with severe neuralgic pain in the right side of the face, along the course of the superior maxillary division of the fifth pair. Since the first attack the pain had been almost constant, and frequently occurred in prolonged and acute paroxysms. Before the disease manifested itself, she was of a full and stout habit, and had enjoyed good health. Her sufferings, however, made alarming inroads upon her general constitution. When we first saw her she was markedly frail and anæmic.

She was able to take but little exercise, and her appetite was poor and capricious. In April, 1868, the ophthalmic branch became affected, and the pain changed its seat, coursing along this nerve and seeming to spend itself behind the eyeballs. Strabismus convergent followed almost immediately, and the eyeballs rapidly projected, until it assumed most unsightly proportions. She had been untiring in her search for relief, but finally became deprived of hope of any amelioration of her symptoms, when the use of electricity was suggested. We made an extremely mild application of a faradic current, and succeeded to a considerable extent in dissipating the paroxysm from which she was then suffering.

During the two days that intervened before the second visit, she suffered, but not so severely as before. When she presented herself for the third application, she had an encouraging account to give. For three nights she had experienced absolutely no pain, and both the strabismus and the projection of the eyeballs were materially lessened. She continued to progress towards recovery during the succeeding few weeks, until her neuralgia was entirely overcome, with the exception of a slight unnatural prominence of the eyeballs. The eyes were restored to their normal appearance and position.

*Neuralgia of the head, accompanied by impairment of sight and vertigo, in a lady aged 70.—Treatment by localized faradization.—Approximate recovery.*

CASE XXXVII.—An aged lady, between 70 and 80 years of age, applied to us on one occasion, by direction of Dr. D. B. St. John Roosa, for the relief of a most agonizing distress in the head.

The pains were evidently neuralgic in character. They darted over the head in all directions, from the forehead to the occiput, but were most severe immediately behind and above the ears. The eyelids were affected to a considerable extent, seeming constricted and heavy; and sometimes, during a paroxysm of more than ordinary intensity, the sight would be much impaired for hours. When the severity of the attack had abated, she would be annoyed by a persistent dizziness, so that she could with difficulty stand erect. Previous to this attack in the head, she had suffered from similar pains that extended up the arm to the breast.

A gentle application of the faradic current to the head, during a most severe paroxysm, greatly relieved her.

Not only was the pain entirely dissipated, and the constriction and heaviness of the eyes removed, but for many hours after she was entirely free from vertigo.

The applications were continued at intervals of several days, for a number of times, and accomplished an approximate cure. Occasionally she suffers from a return of the paroxysms; but they are of a much less severe character than formerly, and are at once dissipated by the current.

*Facial neuralgia of several years' standing successfully treated by localized faradization.*

CASE XXXVIII.—Mrs. S, a patient of Dr. J. O. Farrington, aged 65, had for a number of years been a great sufferer from a most acute form of neuralgia of the face, frequently associated with vertigo and nausea. The point from which the pains radiated and darted in all directions, to the temple, the ear, and even down to the neck, was situated close up to the right ala of the nose.

The patient would occasionally remain a number of weeks comparatively comfortable, but as a rule not more than a few days intervened between the attacks.

A mild faradic current was applied through the fingers of the operator during a season of great distress. This not only alleviated the pain for the time being, but during the two succeeding days, after which she presented herself again for treatment. The relief continued complete.

At intervals the patient was treated in this way for about two months. She had in this time but one or two attacks, slighter than usual. She discontinued treatment, and during the following summer was entirely free from them. In the fall she began to suffer again, and submitted some half a dozen times to the old method of treatment, and to the date of writing, six months subsequently, she has remained free from the attacks.

It is worthy of remark that in this case the galvanic current, however mildly applied, seemed only to aggravate the paroxysms.

*Peripheral Neuralgia.*—Neuritis, neuroma, the continued action of cold or wind, wounds, or other injuries of the nerve—all these may give rise to the peripheral form of neuralgia. Neuritis, or rather inflammation

of the neurilemma, must be regarded as one of the most frequent causes of peripheral neuralgia, and this inflammatory condition may depend upon some form of mechanical irritation, as long-continued pressure of the child's head in labor on the sciatic plexus, or by the concentrated poison of gout, rheumatism, malaria, or syphilis, acting locally. It may, of course, be conceded to the advocates of the purely central theory of neuralgia that there may be a constitutional predisposition to neuralgia, but, on the other hand, it must also be conceded that, in many cases at least, some exciting cause, acting on the periphery, is necessary to develop it.

*Treatment.*—The treatment of peripheral neuralgia should obviously be of a peripheral character; stable faradization and galvanization, and electric moxa. In doubtful cases, that refuse to yield to this method of treatment, it is well also to try central and general electrization.

*Cervico-brachial neuralgia of left side, of six months' standing, in a man otherwise in good health—Recovery under localized faradization and galvanization.*

CASE XXXIX.—Mr. Q., a stout, vigorous gentleman, of middle life, was sent to us by Dr. Jared Linsley, April 1, 1869. The patient complained of cervico-brachial neuralgia in the left side. The pain extended from the occiput down the arm, and was most severe at night: tender point on the occiput. We judged that the neuralgia was of a peripheral character, and of a rheumatic origin.

Three mild applications of faradization gave sensible relief. Twice galvanization was tried, the negative pole being placed on the occiput, over the tender spot, and the positive on the shoulder, or on the side of the seventh cervical vertebra. After the sixth application the patient announced that he was entirely well, and discontinued treatment. Although both faradization and galvanization were manifestly of service in this case, yet the former accomplished the chief part of the task before the latter was brought into requisition.

*Gastralgia.*—Gastralgia may perhaps be included under peripheral neuralgia, although there is room for much discussion on this point. *Our results in gastralgia have thus far been more satisfactory than in any other neuralgia.*

The following case illustrates how utterly futile internal medication is in certain neuralgias, and what a vast difference there is between the remedial power of the faradic and galvanic currents.

*A very severe case of chronic gastralgia of a periodic nature—four years' standing—relieved by galvanization, after failure of faradization.*

CASE XL.—Mr. B., a gentleman from Charleston, S. C., consulted us in January, 1867. The history of his case is substantially as follows: In the latter part of 1861 he was taken with a severe attack of neuralgia in the back of the head and neck. Similar attacks recurred, in paroxysms, every few weeks for about two years. In December, 1863, while suffering from severe pain, colchicum was prescribed, to be

taken every two hours. Not understanding the nature of the drug, he took it every half hour for five hours. This imprudent dosing was followed by persistent vomiting and retching, which lasted for eleven days and nights, producing excessive prostration, and, in the end, total unconsciousness.

Acute gastritis supervened, from which he recovered with difficulty, but only to suffer from neuralgic pains in the stomach, similar in character and severity to the distress which he had previously experienced in the head. These paroxysms were finally subdued by quinine and opium, and for three months he was comparatively well. In April, 1864, the neuralgia in the head returned, for which he took a large dose of morphia. Excessive vomiting was again induced, followed by gastralgia.

From that time until we saw him, January, 1868, *every night had been passed in intolerable agony*. For the first few hours after retiring he would sleep with some degree of comfort; but about 2 to 2½, A.M., the invariable paroxysm would awaken him, and banish for the night all sleep. It was his custom to take immediately forty drops of the tincture of opium, which, for the time being, only aggravated the distress. By its influence, however, the pain abated in about six hours, and in the intervening time he experienced only a dull aching in the epigastric region. Time and again he had endeavored, by the advice of physicians, to gradually decrease the dose of laudanum; but all to no purpose.

It is a most singular and unaccountable fact, that xxxv. gtt. of the narcotic had no effect whatever, while xl. gtt. would act as above stated. Without the anodyne the pain was constant; but he had on several different occasions endeavored to break off from the use of it altogether.

During one trial he abstained from the opium for nearly a week; but the agony became so intense, and his strength so nearly exhausted, that, notwithstanding a resolute will, human endurance reached its utmost limit, and he was compelled to resume its use. Constant suffering had left its impress on his pale and wasted features.

He had a wild and vacant look, and his gait was weak and tottering, like that of an old man on the verge of the grave. For a year past he had been seeking relief at the hands of some of our most distinguished men, and when we asked him what remedies he had been taking, he answered that it would be difficult to say what he had not taken. While he was in Canada his physician had made use of general faradization, but with no appreciable result.

When he came under our care we made use of general faradization, both during a paroxysm and when he was free from pain; but the faradic current seemed to be wholly inoperative.

We then made use of a strong galvanic current, placing the positive pole on the back of the neck, just above the seventh cervical vertebra, and applying the negative over the region of the stomach, in order to affect the solar plexus and pneumogastric.

The application seemed to refresh him, and relieved in a marked degree the vague, dull aching which was always present in the interval between the paroxysms. It so increased his appetite that in a few hours he ate a hearty meal, something which he had not done before in two years.

At the usual hour on the following night the paroxysm returned, but was most singularly located between the shoulders, while the stomach was almost entirely free from pain. After the second application the pain resumed its seat in the stomach, but was not of such a severe character as formerly. Believing that the tonic pro-

erties of the electricity would enable him to do without the opium more readily than on previous occasions, we advised that it be discontinued. It was a most difficult undertaking; but, for three weeks, until he was imperatively called South, not a particle passed his lips. He received in all but six applications of the galvanic current, and although the cure was by no means complete, yet the relief he experienced was positive and most gratifying.

His appetite remained permanently better, and digestion was performed with more comfort and rapidity. The regularity of the paroxysms was broken, and their severity ameliorated.

The wild, wandering look of distress, which was ever stamped upon his features, gave place to a calmer and more hopeful expression. Unfortunately, circumstances rendered it impossible for him to remain longer at the North; but sufficient benefit had been derived, during the brief time that he was under our care, to render it probable that still further amelioration of his remarkable symptoms would have been obtained by a persistent use of the galvanic stream. We were the more hopeful, from the fact that on a previous occasion we had treated successfully, by general electrization with the faradic current, a lady suffering from this form of neuralgia, but of a less aggravated character.

So far as regards the treatment of this case, the point of particular interest lies in the fact that the galvanic current was of value, while the faradic was wholly inoperative. By the use of the galvanic current the pain was immediately relieved, the digestion was strengthened, and the appetite sharpened.

*Abdominal neuralgia of an agonizing character, associated with muscular spasms—Decided temporary relief from local galvanization—Subsequent improvement which possibly might in some measure have been due to the secondary effects of treatment.*

CASE XLI.—Mrs. H., who suffered from most agonizing abdominal neuralgia, was referred to us in April, 1871. The complications in this case were peculiar.

The paroxysms of pain were associated with spasmodic contractions of the abdominal muscles of such severity as to necessitate the constant use of subcutaneous injections of morphia.

Ten years ago the patient miscarried, and for two years thereafter she was annoyed occasionally by slight neuralgic pains. Menorrhagia now supervened, and after existing two years it was apparently cured, and for eighteen months she enjoyed fair health. During the last two years menstruation had recurred but two or three times, and her sufferings were terrible. She was taking, by subcutaneous injection, eight grains of morphia daily, and so persistently had it been administered that hardly a point on her body or limbs could be found that was not of that peculiar hard character, the result of the repeated operations. There was uterine displacement associated with local complications, of the character of which we are not informed. Our treatment, begun Feb. 25, 1871, was external and local, with an occasional general application of the faradic current. Electrization, on the whole, did not accomplish decided permanent good, unless the results observed after the cessation of our treat-



ment were in a measure secondary to the electric stimulus. The patient certainly gained immensely during the following year. Temporarily local galvanization was of much service. It frequently induced sleep, reduced the intensity of the paroxysmal pains, and often rendered her more comfortable during the intervening periods.

*Severe gastralgia of fourteen years' standing—Periodical attacks at night—Rapid and permanent cure under central galvanization after failure of faradization.*

CASE XLII.—Dr. S. J. H., a physician aged about 36 years, consulted us in the autumn of 1870. For fourteen years he had suffered from attacks of gastralgia of a most violent character; these attacks came on usually at night, while in bed, after midnight, before or about two o'clock; the attacks would last sometimes several hours, and the pain was of the most distressing character. Of the various methods of relief that he had used, alcoholic liquors seemed to be the most efficacious, but the respite they caused was only temporary. The appearance of the patient suggested robust health; nutrition was well maintained, and the functions were generally well performed.

Examination gave little information. Disease of the heart had been suspected, but the careful and repeated examinations of Dr. Thayer established the fact that there was no disease of that organ. Tenderness of the epigastrium in one spot sometimes, but not always, existed. We suggested central galvanization. The patient had previously tried faradization without any benefit. We had little hopes of helping the patient; the persistency and fixity of the symptoms and their periodicity gave an unfavorable prognosis, and only by our urgent solicitations did the doctor allow us to experiment on him.

Treatment by central galvanization was commenced January 3, 1871, and was kept up for two months, two or three times weekly. In less than two weeks benefit was apparent; the periodicity and violence of the attacks were somewhat modified, and in a month it was evident that the disease would yield more or less permanently to the treatment. Occasional relapses occurred, as always in similar cases, reminders of the former sufferings, showing that the evil spirit was not wholly cast out; but in three months from the time the treatment was commenced, the patient regarded himself as well.

Three years have elapsed, and the patient is still well, although engaged in laborious duties. The features of chief interest in the case were these:

1. The superiority of central galvanization over faradization.
2. The permanency of the cure of such a long-standing affection.

*Sciatica.*—In the treatment of sciatica by electrization very much depends upon the care with which the current is applied. An ill-directed, too prolonged application, or the use of a current the mechanical effects of which are unduly marked, frequently results in more harm than good. In sciatica, the pain, as a rule, closely follows the course of the nerve, and, therefore, in the majority of instances the disease is

typical of true neuralgia. The effects of faradization in these cases are undoubted, and in our hands have sometimes proved far more efficacious than galvanization.

It cannot be too frequently repeated, that in sciatica the faradic current is capable of doing infinite harm if ignorantly used or over-used, but that if applied with that caution and skill which experience alone can give it generally relieves.

It is in just such conditions as these that the character of the current for fineness and evenness is all-important, and these factors are found combined in a higher degree in Kidder's single-coil machine than in any other. On account of the great caution that must be exercised in the treatment of sciatica by faradization it is probable that beginners may here achieve greater success through the use of mild galvanic currents. The muscular atrophy that sometimes follows sciatica may be treated by localized faradization. Whichever current is used the application should be made both over the lower part of the spine, to act upon the roots of the nerves, as well as over the course of the nerve in the leg.

*Galvano-Puncture.*—We have recently attempted the treatment of sciatica by electro-puncture.

The needle may be insulated or not; should be bayonet-shaped, so as to go in easily, and may be inserted far enough to touch or penetrate the nerve. The moment when it so penetrates or even touches will be revealed to the patient by a tingling or pricking sensation through the leg.

The needle thus introduced should be connected with the negative pole; but two to four cells should be used, and the current should be continued but a few minutes.

*Severe and obstinate sciatica excited by obstruction of the bowels—Relief and slow improvement under localized galvanization with moistened sponges, with the metallic brush, and galvano-puncture.*

CASE XLIII.—Mr. K., aged 39 years, was referred to us, March 3, 1873, by Dr. Conkling. The patient had been occupied by various and complex affairs, and had been for years bearing the burdens of ten men. His vacations had been few and his hours of labor many, and he had fallen into a condition of profound neurasthenia. He had suffered from gastralgia of a most violent character, for which opiates had been quite freely given; and constipation and hardened feces had resulted that had caused obstruction of the bowels, which was relieved only with difficulty and by mechanical means.

The sciatica of one side, from which the patient was suffering when we were called in, seemed to be of a reflex character from the constipation. The pain was fearful, and there was, of course, lameness and atrophy of the muscles of the leg. At times excessive hyperæsthesia appeared over the thigh, especially in the region of the sciatic nerve, and there was great tenderness.

We tried various methods of electrization ; general faradization, for the patient was much debilitated ; localized faradization with sponges and with the metallic brush ; central galvanization, localized galvanization, and galvano-puncture.

Localized galvanization with currents of medium strength, and continued for an hour or so just as the patient had retired for the night, seemed to be more efficacious than any other method or manner of treatment. Almost always it soothed the pain, relaxed the stiff and aching muscles, and this relief would last for hours, perhaps give a good night's sleep. The proceeding was to place one pole on the spine, and to pass the other, without regard to the direction of the current, up and down over the region of the sciatic nerve.

A few times we tried galvano-puncture with insulated and non-insulated needles. The needles were thrust in quickly and firmly until they came near the nerve, and sometimes they touched it, as was evidenced by the tingling and pricking sensations excited that were felt down the leg. The punctures were made on various points down the back part of the thigh. No anæsthetic was used, but once or twice local anæsthesia by means of carbolic acid and ether.

We were persuaded that this treatment by puncture did good ; that it gave the patient a start, and enabled the external galvanization to do its work at better advantage. The patient, though a man of strong will and decision, terribly dreaded the thought of the needles, and we were obliged to abandon their use. The needles were always connected with the negative pole, the positive being applied externally by a sponge or cloth cover.

This case was treated off and on for four months, and with slow and not very steady improvement. It was a long time before the patient could ride or sit long without causing pain. In a few weeks he completely recovered.

*Sciatica from strain, of several months' duration—Immediate improvement under general faradization and localized galvanization—Subsequent relapse and final recovery.*

CASE XLIV.—Mr. W., aged about 40, was referred to us by Dr. C. E. Buckingham, of Boston.

The patient had been suffering for several months from severe pains along the course of the sciatic nerve. He had not been especially exposed to cold, and as the symptoms came on suddenly, he could only attribute the disease to the unusual exertion of lifting a heavy trunk a short time previously.

The limb had atrophied somewhat, and the general health of the patient was somewhat impaired. He was submitted to general faradization and to galvanization of the affected limb. A dozen applications resulted in very great alleviation of the severe pain which had for so long a time distressed him, and we felt hopeful of a speedy recovery. Unfortunately the patient exercised too freely in walking one day, and in addition probably took some cold. At all events the neuralgia returned in full force, and so discouraged the patient that he almost immediately sailed for Europe, where after a number of months he recovered.

The value of the faradic current is illustrated in the following case :

*Sciatica of several months' duration successfully treated by faradization.*

CASE XLV.—An old gentleman, aged 76, was sent to us by Dr. F. Elliot to be treated for a condition of general paresis, associated with which was a severe neuralgia of the sciatic nerve in both limbs which had distressed him for a number of months.

There was a lack of co-ordinating power in locomotion, together with decided anæsthesia of both upper and lower extremities. The left foot and ankle were enormously swollen, and in this limb the pain was far more severe than in the other.

The patient was treated by general and local faradization; and in the course of seven applications the swelling nearly subsided, and the neuralgia was quite subdued. The patient subsequently died from cerebral effusion.

*Sciatica following pressure of the child's head at parturition—Localized galvanization is followed by alleviation of pain and recovery.*

CASE XLVI.—Mrs. —, aged about 40, was confined in March, 1873, and after great suffering, and by the use of the forceps, she was delivered of a still-born child. Through the pressure of the child's head the nerves had sustained serious shock, and for many days before seeing her she had endured the most severe neuralgic pains in the left limb.

Nothing seemed to give more than temporary relief, and at the time that we were sent for by her physician, Dr. Oliver White, the onset of hysterical symptoms rendered the patient a most pitiable object. It was with difficulty that she could be induced to submit to treatment, but finally a mild application of localized galvanization was administered, and seemed to be soothing in its effects. The total number of applications given was eight, and, with the exception of one séance which was followed by increased pain, every treatment resulted in an alleviation of suffering, and finally recovery was complete.

The pain had not entirely left her when the galvanization was discontinued, but grew less and less every day for a week or so until her limb was in good condition.

Dr. V. P. Gibney,\* of New York, has reported the results of 32 cases of sciatica, treated by the "Strong galvanic current": 24 received immediate temporary relief, 3 were moderately benefited, and 5 received no relief; 16 were permanently cured without a relapse, 7 relapsed, but subsequently improved. The further histories of 5 cases were not traced. About thirty Leclanche elements were employed.

*Reflex Neuralgia.*—The term reflex, as applied to paralysis, is at once common and suggestive. In the same way it is applicable to neuralgia.

As in children paralysis frequently follows the irritation of teething or dysentery, and in older persons that of urinary disease, so neuralgia of distant parts may result from uterine and other disorders. Neuralgia of the fifth pair, caused by a carious or false tooth, is a common and well-known reflex result of mechanical irritation. The treatment of reflex neuralgia is by no means so empirical as that of the peripheral variety. If a carious tooth is at the root of the evil it must be removed.

\* Transactions of Am. Med. Association for 1880.

If the cause can be traced to uterine disease, the skill of the gynecologist is called for. Occasionally electrization, through its power of subduing local irritation or inflammation, effectually relieves the remote neuralgic pain, of which the irritation or inflammation is the cause.

*Neuralgia of left leg, apparently proceeding from ovary—Recovery.*

CASE XLVII.—In the case of a young lady who had suffered for several months from the most severe neuralgic pains down the left leg, tactile examination revealed very marked tenderness to pressure in the left ovarian region. No other portion of the body was especially susceptible to the touch. It is proper to state that the patient was not at all hysterical, that exercise aggravated the pain, and that the neuralgia of the limb was in proportion to the tenderness over the ovary. She was immediately relieved by localized faradization, and completely recovered in the course of six weeks, after having received twelve applications.

*Neuralgia in the ovarian region, over the abdomen, and extending down the limbs, of several years' duration—Complete relief under general faradization.*

CASE XLVIII.—Miss L., about 23 years of age, and a patient of Dr. Frederic D. Lente, had for several years suffered much distress from a neuralgic affection of the abdomen and lower extremities. The pain was especially severe and constant in the region of either ovary. According to the Dr., uterine difficulty evidently existed; but as local treatment was out of the question, and as the ordinary external and internal remedies had been used without much benefit, we were requested by Dr. Lente to test, in her case, the effects of electrization. Simple general faradization proved most efficacious.

Some dozen applications sufficed to dissipate completely the pains from which she suffered and to markedly improve her general condition.

A year subsequently the above patient was annoyed again by the same symptoms, but a short course of the same method of treatment relieved her a second time.

*Galvanic belts and disks* for the treatment of neuralgia have been recommended by Hiffelsheim. He applies the belts—either Pulvermacher's or Davies'—moistened with vinegar, to the painful locality, and allows them to remain there for days, weeks, and even months. Although Hiffelsheim reports some good results from these applications, yet it must be admitted that there is as yet no sufficient, reliable evidence that they have succeeded where galvanization or faradization has failed, or that they have any positive advantage whatever, except, perhaps, for those who are so situated that they cannot receive ordinary treatment.\*

\* The therapeutic results obtained by wearing galvanic chains, belts, disks, soles, girdles, etc., must depend on the manner of their construction and application. Many of those which are sold in the stores and extensively and indiscriminately used by the laity, are so arranged that the feeble currents which they may generate fail to make a circuit through the body, and recombine in the metals themselves.

The objections to and disadvantages of this method of treatment in neuralgia, as in all other affections for which it has been so widely employed, are these :—

1. The current which they generate is very feeble and inconstant, and probably does not, except under peculiarly favorable circumstances, penetrate far beneath the epidermis.

2. They can only be used locally. Many of the symptoms for which they are used are of a constitutional character, and can only be permanently dispelled by measures calculated to affect the whole system.

3. They are usually, and sometimes necessarily, applied to the seat of the pain rather than to the seat of the disease. In galvanization and faradization for local neuralgia, it is found that the best results are obtained by treating the seat of the disease.

4. They sometimes cause ulcers that leave permanent cicatrices.

The benefit that is derived from them is probably due in part to their influence on the imagination.

These arguments against the use of galvanic belts would be valueless, if experience could demonstrate from their use any great utility or any very positive advantage.

It is not impossible that, in future improvements in the construction of these belts and chains, and more scientific experiments in their use, we may develop advantages from them which they have thus far failed to exhibit, and may accord to them a position in electro-therapeutics to which, from the results of the past, they are not entitled.

The fact that they have thus far been used almost exclusively by the laity, and have been made the theme of noisy advertisements, so far from discouraging, should rather stimulate men of science who have any faith in their efficacy to rigidly investigate and interpret their claims to a position among the appliances of electro-therapeutics.

Those, however, who experiment with these contrivances, should remember that the mechanically irritating effects of metallic bands applied to the tender skin are not inconsiderable, and that the therapeutic results which appear to follow their application may not unlikely be due wholly, or in part, to *counter-irritation*.

*(For further remarks on this subject, see Myalgia.)*

## CHAPTER XIX.

### ANÆSTHESIA.

ANÆSTHESIA is derived from *a*, privative, and *αἰσθάνομαι*, to perceive, and therefore literally signifies a deprivation of sensation. It is a symptom of some organic or functional disease of the central or peripheral nervous system. The kinds of anæsthesia are as various as are the nerve ramifications, and the symptoms that accompany it are modified by the locality and causation of the disease. All forms of anæsthesia, as of paralysis of motion, may for the sake of convenience of description be classified under these four general divisions: Constitutional, central, peripheral, and reflex.

There are five kinds of sensibility, all of which are, of course, modifications of general sensibility, and all of which may become diminished by disease:—

1. *Tactile sensibility*.—This is the form which is most frequent, and best appreciated. Diminution or loss of this sense is usually known as *anæsthesia*.

2.—*Sensibility to temperature*—heat and cold.

3. *Sense of pressure or weight*.

4. *Sense of pain*.—This is quite distinct from tactile sensibility, with which, on superficial observation, it is often confounded. The loss of this sense is called *analgesia*. These different kinds of sensibility may be very unequally affected by disease. One form may be entirely destroyed, while the others remain intact. Thus, while tactile sensibility is perfect, the prick of a needle, when thrust into the flesh, is not felt. In such cases there is *analgesia*, but not *anæsthesia*.

5. *Farado-sensibility*.—This form of sensibility appears to be sufficiently distinct to entitle it to special mention. Farado-sensibility may be quite active when tactile sensibility is much diminished.

The diagnosis of anæsthesia, except in very delicate cases, is sufficiently easy.

The degree of normal sensibility to tactile impressions varies widely in different parts of the body. It is necessary to bear this fact in mind,

and to make experimental trials on persons in health, in order to arrive at correct conclusions in cases of disease.

The use of the compasses, according to the directions of Dr. Weber,\* will enable one to determine in a very accurate manner the condition of the sensory functions in health and disease.

Thus, when the two points of a pair of compasses are placed upon the inner surface of the last phalanx of the finger, they need to be separated but one line in order to give two impressions, while, in the middle of the thigh, the points of the compasses need to be distant from each other some fifteen to twenty-five lines in order that two impressions may be received.

Sensation in the tip of the tongue is more acute than in any other part of that organ, for two impressions are received when the points of the compasses are separated by only half a line; and it will be found that, in the face, this sense of acuteness diminishes as we recede from the mesial line.

*Electro-diagnosis.*—There is a method of determining the relative electro-sensitiveness of the two sides of the body that we have found very convenient and reliable, and sufficiently delicate except for those cases when the anæsthesia has extended over the entire system. This consists in the application of the faradic current by means of a brass ball, or other metallic electrode, attached to one of the poles of a faradic apparatus. The other pole of the apparatus may be placed at the feet of the patient, or at the coccyx, or at any indifferent point, as may be convenient.

Different points of the body, on both sides, are *alternately* touched with the brass ball, perfectly dry, very lightly, and with a mild current. In order to test the sense of pain, the ball should be covered with a moist sponge, so that the current may penetrate the epidermis. In this way a very slight difference of sensibility, especially of the upper and lower extremities, can readily be detected. By gradually increasing the power of the current up to the point of endurance, the extent of the anæsthesia can be ascertained with tolerable accuracy. One great advantage of this method is, that the same apparatus with which we treat the disease can be used to diagnosticate it, and to mark the progress from day to day.

*Treatment.*—When the anæsthesia is very limited in its extent, and the general health of the patient is otherwise good, localized electrization is of course indicated. As a matter of fact, however, very many anæsthetic

\* De puls. resorptione, auditu et tactu, annotationes anatomicæ et physiologicæ. Lipsiæ, 1834.



patients, whatever may be the cause on which their symptoms depend, are more or less debilitated, and are benefited by the constitutional tonic effects of general electrization. In cases of anæsthesia that are dependent on lesion of the central nervous system, central galvanizations is sometimes indicated. Obstinate cases of a localized character are well treated by the electric brush. Anæsthetic patients will generally bear strong currents in proportion to the extent of the anæsthesia with benefit and without injury. Some temperaments that do not feel the current during the application may yet experience unpleasant reactive effects.

*Prognosis.*—The prognosis in anæsthesia, waiving for the moment all questions of causation or pathology, is usually very favorable, and beyond comparison more favorable than that of paralysis of motion.

One reason for this difference is that anæsthesia is an earlier symptom of organic disease of the nervous system than motor paralysis, and is therefore sooner treated. But we continually observe, even when the two conditions coexist, as is so frequently the case in central, spinal, and peripheral paralysis, that the anæsthesia yields much sooner and far surer than the paralysis of motion.

The discussion of the interesting physiological questions suggested by these observations, though somewhat enticing and suggestive, does not come within the scope of the present work.

*Anæsthesia of anterior region of right thigh, of traumatic origin, of ten years' standing—Permanent recovery under localized faradization.*

CASE XLIX.—Mr. H., a stout, vigorous man aged 29 years, was sent to us by Dr. H. Gregory, of Harlem, to be treated for anæsthesia (which had annoyed him for many years) of the anterior portion of the right thigh. The only possible cause to which we could refer the symptoms was an incised wound that he had received in the thigh, near the great trochanter, some ten years previously.

The patient could not positively state that the paralysis of sensation immediately followed the injury, since the anæsthesia was not so noticeable as at a later date. The part had become so insensible to ordinary impressions, that it was necessary to separate the points of a pair of compasses some 45 to 50 lines, before two impressions were received. The pricking of a pin caused no sensation, and even when the point penetrated several lines beneath the surface, no pain was experienced.

Dissipation in eating and drinking, unusual exercise and loss of sleep, invariably aggravated the disorder. The first application of the faradic current—made down the spine and to the affected limb—very markedly relieved the anæsthesia, and after the third application the limb was restored to its normal sensibility. At the fourth visit he complained that the part had partially relapsed into its former anæsthetic condition, but accounted for it from the fact that he had spent most of the previous night at a social gathering.

An application again relieved the anæsthesia. We found, as usual in all cases of anæsthesia, that, as the limb progressed toward a cure, it became more and more sensitive to the influence of the current.

After receiving ten applications the limb was again restored to its normal sensibility, although occasionally, after unusual exertion and loss of sleep, it became somewhat anæsthetic.

In the case of this gentleman, the wound before referred to was over the course of the external cutaneous nerve, after it passed beneath Poupart's ligament, and the beneficial results that followed treatment by electrization were due, doubtless, to the fact that the nerve had suffered merely from contusion and not division.

Hysterical hyperæsthesia is much more commonly noticed with us than anæsthesia. The latter condition is without doubt occasionally overlooked, and again may sometimes be feigned.

*Hysterical anæsthesia—Diminution of temperature during the attacks—Great insensibility—Gradual improvement and final recovery under general faradization.*

CASE L.—Mrs. S., aged 33, was subject to frequent attacks of hysteria, with intense melancholy. She suffered also from general neuralgic attacks, which were followed by almost complete anæsthesia—commencing at the fingers of either hand, extending up to the arms, the shoulders, and face, and finally involving the tongue, so that her speech was only in broken utterances.

About the finger-nails the skin assumed a dull leaden color. The pulse was almost imperceptible, and the temperature of the affected parts was considerably below the normal. Insensibility to painful impressions, which always preceded the loss of the sense of touch, was at first incomplete, but gradually increased. During the attack her memory always became much impaired, so that she was often unable to call to mind the names most dear to her.

The paroxysms lasted from twenty minutes to half an hour, and were followed by a severe headache, while a considerable numbness of the arms and hands remained for several days. Carbonate of ammonia seemed to relieve her more quickly than any other internal remedy, but nothing she had ever tried had been of any very permanent benefit. An application of the faradic current, made to the parts affected during a paroxysm, always shortened the attack; although, while the anæsthesia lasted, the fingers, arms, face, and tongue were insensible to the influence of a current of considerable power.

Treatment by general faradization was continued during the interval between the paroxysms, resulting in a diminution in the severity of each succeeding attack, until in a few months they ceased to trouble her.

*Anæsthesia of left side of face, extending to left nostril and internal surface of cheek, and complicated with paralysis of motion—Improvement and recovery under faradization.*

CASE LI.—Miss A. G., an unmarried woman, aged 28, applied for treatment for cutaneous anæsthesia of the left side of the face. She was employed in a book-

hindery, and her daily labor extended over a period of from twelve to fourteen hours. As a natural consequence, her general health had become somewhat impaired.

Her menstrual function was, however, performed regularly; and, although her digestion seemed to be vigorous, she was nervous and anæmic.

She gave the following account of herself: Some six months previously, she noticed, at the close of a day of hard labor, and after exposure to a cold biting wind, a slight feeling of numbness in the right side of the face. This numbness rapidly increased, until in a short time the anæsthesia was complete. On examining the face it was found that the mouth was drawn somewhat over to the right side. There was slight ptosis of the left eyelid, and the left cheek was flaccid. The want of expression was quite marked on the affected side, and contrasted strongly with the right side when she laughed, or entered into conversation. She was entirely insensible to ordinary impressions on the left side of the face, and the anæsthesia extended to the *left nostril and the internal surface of the cheek.*

The sensation and movement of the tongue, and the power of taste, were unimpaired. Local applications of the faradic current were given every day or two, but for some little time no impression seemed to be made on the diseased nerve.

It was only after treatment had been continued two weeks, and some eight applications had been given, that any sensitiveness to the current was manifest along the course of the fifth pair. The improvement, however, from this time, although slow, was constant.

In this case the rule that the anæsthesia improves more rapidly than the paralysis of motion was reversed.

The anæsthesia improved but little until the face assumed its natural proportions, when, in a short time, the normal sensation entirely returned. The treatment was continued during two months. In most cases of anæsthesia of the trigeminus, related by Romberg, the loss of sensation was so marked that deep pricking with a needle caused no pain, while in this case the anæsthesia was limited to the skin and mucous membrane. Anæsthesia of the fifth pair of nerves may be peripheral or central; in the latter case there is coincident paralysis of the nerves of motion and sensation, and hemiplegia, more or less complete, is often present.

The diagnostic symptoms of this variety of paralysis differ, according as the seat of the disease is located in the course of the various ramifications of the fifth pair, after it leaves the sphenoid bone, or in the Casserian ganglion, or at the base of the brain.

The symptom of anæsthesia occurs in many forms of paralysis of motion—hemiplegia, paraplegia, and so forth—and many cases will be found under those diseases. Anæsthesia occurs also in writer's cramp and in locomotor ataxia, where it is a prominent symptom. In all the diseases where it exists as an incident or complication it is to be treated on the same principles as where it exists as the sole or leading symptom.

## CHAPTER XX.

### PARALYSIS.

**PARALYSIS** of motion is a condition for which, from the earliest history of electro-therapeutics, electricity in its different forms has been used more than in any other disease ; and not until quite recently has it been demonstrated that there are many other symptoms in which the results of electrical treatment are much more rapid and brilliant than in any form of motor paralysis. In hysteria and affections allied to it, in cerebral and spinal congestion, in chronic alcoholism, neuralgia, and in certain diseases of the skin, electricity rightly used by the methods of central galvanization, general faradization, and local galvanization of the nerve centres, relieves and cures far more rapidly than in paralysis.

Paralysis has been especially prominent in electro-therapeutics, for the reason that oftentimes electricity is the only remedy to which it yields. Those who have restricted themselves to localized electrization have always given their chief attention to different forms of motor paralysis, but even now the impression yet lingers that it is about the only disease for which electricity is indicated.

All forms of paralysis, as of neuralgia, may, for the sake of convenience of description of therapeutical indications, be included under one of these four divisions :—

1. Constitutional.
2. Central.
3. Peripheral.
4. Reflex.

*Constitutional Paralysis.*—This term is applied to those paralyzes which arise from some blood-poison or constitutional degeneration.

Among the more common causes of this variety of paralysis may be mentioned hysteria and the poisons of certain diseases, as gout, rheumatism, syphilis, mineral poisons, as lead and opium, etc.

*Rheumatic Paralysis.*—In the partial but persistent paralysis that occasionally follows subacute muscular rheumatism, faradization has proved exceedingly efficacious. The muscles most frequently affected

by rheumatic paralysis are the deltoid and trapezius (in consequence of which it becomes impossible or difficult to lift the arm from the side), the extensor muscles of the forearm, the muscles of the lower extremities, and occasionally the inter-ossei and lumbricales muscles.

*Electro-Diagnosis—Treatment.*—The electro-muscular contractility in recent cases is normal ; in long-standing cases, diminished. General as well as purely local treatment is frequently required in paralysis of a rheumatic origin, in order to combat the rheumatism in the constitution, as well as its local manifestations (see chapter on Rheumatism).

In this, as in other forms of paralysis, atrophy of the muscular tissue occurs after a certain length of time. It is extremely important to begin treatment before the muscles become thus affected. In cases of rheumatic paralysis, where the invasion has been sudden and the pain considerable, electric excitation produces pain ; but where the invasion has been more gradual and unattended by pain, electric excitation causes very little, if any sensation.

*Rheumatic paralysis of deltoid, of several months' standing—Recovery under general and localised faradisation.*

**CASE LII.**—A patient, a young lady aged 23, had been unable to raise her hand from her side for several months. The access of the rheumatism was gradual, and unattended by acute pain, excepting when pressure was made over the affected muscle, or when she attempted to raise the arm. An application of the faradic current caused pain only when it was sufficiently intense to produce contractions.

The muscle rapidly became less sensitive to the influence of the current, and gradually regained its lost power. The restoration of strength was complete in two weeks.

We have treated quite a number of cases of rheumatic paralysis of the deltoid, the trapezius, and of the lower extremities, and usually with the most satisfactory results. Electricity is always indicated in this condition, and few cases, doubtless, would fail to improve, even if they do not recover under its influence.

*Syphilitic Paralysis.*—Syphilitic nervous affections may exist either with or without appreciable structural change. Paralysis which results from secondary syphilis may derive benefit from electrical treatment.

The principles and method of treatment are the same as for rheumatic paralysis. There is as yet no evidence that general faradization or central galvanization have any special influence over the syphilitic poison ; they act as general tonics and thus help the system to contend with the disease.

*Lead Paralysis.*—In slow poisoning by lead the metal becomes dif-

fused throughout the whole system, and exerts its influence, though in an unequal degree, on every nerve and organ.

As is well known, however, the upper extremities are most frequently affected by paralysis (more or less complete). The muscles usually affected are the extensors of the hands and fingers, so that they hang down by their own weight. It is probable that these muscles are chiefly affected in this disease, as in hemiplegia, because they are weaker and operate at a great mechanical disadvantage.

*Electro-Diagnosis and Treatment.*—The electro-muscular contractility of the affected part, in this form of paralysis, is always diminished; and frequently it is entirely lost, even in cases where there is little or no atrophy of the muscles. The electro-muscular sensibility is usually unimpaired. Diplegic contractions may appear in this disease. According to Hitzig, mobility in cases of lead poisoning is lost before electric contractility.

If the electro-muscular contractility is completely lost, it is better to apply a mild galvanic current to the paralyzed part for a few minutes before the faradic is made use of. The latter current should be used daily, and not longer than ten or fifteen minutes at each sitting. As soon as the slightest contractions are produced by the faradic current, the galvanic may be discontinued. In some cases we have thought that the galvanic current answered better than the faradic, even when the muscles respond to the faradic.

*Lead paralysis of nine months' standing dropped wrists—Approximate recovery under localized galvanisation and faradization.*

CASE LIII.—F. H., aged 24, afflicted with lead paralysis, gave the following history: For several years he had worked almost constantly in lead, and about nine months prior to his application for relief he became obstinately constipated, suffered from vague pains in the legs, shoulders, and over the body generally, and in a short time he observed a decided lameness in the wrists. He gradually became worse, until he found it impossible to raise the right hand at all, and over the little finger of the left hand he had but little control.

No contractions of the affected muscles followed localized faradization; the galvanic current produced slight contractions.

The patient was treated for some weeks by a galvanic current, just sufficient in strength to produce slight muscular motion; and subsequently, when the faradic current was tried, the muscles reacted appreciably to it.

The treatment was kept up for two months and resulted in an approximate return of the normal strength to the affected parts.

*Paralysis from Opium, Stramonium, Arsenic, etc.*—In desperate cases of poisoning by opium, electricity has been repeatedly used with

success. The method of artificial respiration may be used (see chapter on *Artificial Respiration*).

After recovering consciousness from severe poisoning by opium, or other poisons, the various limbs of the body are occasionally left in a permanently paralyzed condition that persistently resists all the efforts of nature and medicine. Two such cases have fallen under our observation.

*Partial paralysis of upper and lower limbs, caused by an overdose of opium—Improvement under general faradization.*

CASE LIV.—A little boy, some eight years of age, was presented to us suffering from partial paralysis of the lower limbs, and, in a less degree, of both arms also. He could walk only with the assistance of another, and then with an uncertain, staggering gait. His legs were remarkably small and cold, his bowels continually constipated, and his general condition feeble. When but three years old, his nurse on one occasion administered to him by mistake a teaspoonful of the tincture of opium.

By persistent efforts only was his life saved; but the shock to his nervous system was so great that, for one year after, both legs were completely paralyzed. Finally he regained a portion of strength, until he reached the condition already described.

The electro-muscular contractility and electro-sensibility, not only of the limbs, but of the entire body, was much improved. The boy could bear, without pain, a faradic current of sufficient intensity to prostrate a grown person in ordinary health. The first general application seemed to benefit him.

He felt lighter and better. Six subsequent séances increased his appetite, perceptibly augmented his strength, and relieved his constipation. At this time his legs began to feel somewhat warmer, while he was unable to bear a current of as great intensity as before. The patient was under treatment some two months, and received about twenty-five applications. The temperature of his legs, and of his whole body, had very decidedly improved.

His legs had grown larger, and when he discontinued treatment his general health was fair, and his gait nearly normal.

*Hysterical Paralysis.*—The hysterical form of paralysis is constitutional, because the entire central nervous system is degenerated into a condition of abnormal susceptibility (see chapter on Hysteria and allied Affections).

*Electro-Diagnosis.*—In this form of paralysis, the electro-muscular contractility in recent cases is unimpaired; in old cases it may be impaired or lost, or the electro-sensibility may be very much blunted. Diplegic contractions sometimes appear in hysteria. The loss of power is usually incomplete, and sooner or later recovery usually takes place.

*Treatment.*—The disease is constitutional and demands general as well as local treatment. In many instances general faradization pro-

motes rapid recovery ; other cases are very rebellious and only improve up to a certain point. The general treatment may be combined with central galvanization and faradization of the affected part.

The following case is an example of its influence in the transient form of this affection :—

*Hysterical paralysis of right arm—Attacks frequently repeated—Immediate relief from localised faradisation.*

CASE LV.—A young lady, of an excessively nervous organization, was frequently subject to hysterical attacks, when one of her arms (generally the right) always became perfectly anæsthetic and almost powerless. As a rule, her arm remained in this condition about an hour.

On one occasion, immediately after an attack, a powerful faradic current was directed for two minutes through the arm, from the wrist to the shoulder, completely dissipating the anæsthesia and restoring the lost power. Many similar applications, during subsequent attacks, invariably produced the same result.

*General paralysis of an hysterical character, with loss of motion of both the upper and lower limbs, and severe atrophy of the muscles of the upper limbs—Remarkable symptoms—Very great improvement but not absolute recovery under peripheral and central galvanization.*

CASE LVI.—Mrs. S., of Staten Island, aged 41, was the most remarkable illustration of the efficacy of galvanization in paralysis that has ever fallen under our observation. The patient first came under our care Sept. 25, 1868. Nine months before she suffered a miscarriage that had left her in a condition of utter helplessness. Both upper and lower limbs were completely paralyzed, the only power remaining being a slight limited movement of the fingers. The hands were permanently extended, the inter-osseæ greatly atrophied, and the muscles of the arm and forearm were so much shrunken that the circumference of the arm was diminished to the extent of between one and two inches. The lower limbs were absolutely motionless—not a muscle gave even the feeblest response to the will. The muscles of the lower limbs were but little atrophied even below the knee ; but the skin presented a peculiar glossy appearance that is associated with greatly impaired nutrition, which has been described by Drs. Mitchell, Morehouse, and Keen.\* There was, however, no pain, which these physicians found to be an invariable accompaniment of glossy skin—that resulted from injury to a nerve. The appearance of the skin may be best understood by comparing it to a cicatrized wound. This appearance was most marked below the knees. Both upper and lower limbs were very cold and very sensitive to cold. *There was no loss of power over the bladder or rectum.* Appetite and digestion were good, but there was some dyspnœa. The patient also slept well usually, although compelled to lie constantly on her back unless she was turned over. The important feature of the case was the remarkably healthful performance of most of the vital functions, conjoined with absolute helplessness. As the little motion of her fingers was not sufficient to enable her to grasp even the lightest object, it was necessary for the nurse to feed

\* Gunshot Wounds, and other Injuries of Nerves. 1864. Pp. 79, 80.



her. Daily she was lifted out of bed and placed in an invalid's chair that could be lowered into a horizontal position. To sit up in an ordinary chair was impossible, since the flexion of her limbs caused unbearable pains in the joints.

The brain was usually clear, though the memory had been somewhat impaired. The patient was surprisingly buoyant; but sustained mental exertion, even the reading of a short paragraph, was followed by sensations of weariness.

The patient was of a nervous constitution, had never been capable of great exertion and for a long time before the attack had complained of numbness, tingling, and other premonitory symptoms.

*Electric examination* showed, as was expected, absolute loss of electro-muscular contractility, in both the upper and lower limbs, to the faradic current. A strong galvanic current produced feeble contractions in the extensors and flexors of the fore-arms, but none whatever of the muscles of the lower limbs. There was also very great anæsthesia. Analgesia existed in the lower limbs. In the arms, forearms, and fingers, there was *excessive hyperæsthesia of the sense of touch, conjoined with decided analgesia*. A tolerably strong current localized in the muscles was not painful, but the slightest touch on the surface was unpleasant. Two important features of the case were *reflex spasms of the muscles of the lower limbs during electrization, and a peculiar sensation through the whole nervous ramification after electrization*. The patient compared it to "waves of sensation" rolling up and down the limbs.\* This sensation was sometimes felt one or two days after the application.

Taking into consideration all the facts of the case—the completeness of the paralysis, the loss of muscular contractility, the absence of pain in the limbs or in the spine, the absence of any morbid symptoms in the rectum or bladder, or of a feeling of constriction in the abdomen, the absence of spinal tenderness, or of a sensation of pain when ice or hot water were applied to the back, and the various and peculiar behavior under electrization, we concluded that the case was one of a hysterical character.

The treatment consisted chiefly in central and localized electrization three times a week. Both methods were used at the same sitting. At first the faradic current was used, but without making any impression on the disease. The first application of the galvanic current took immediate effect. The next day the patient could raise both of her lower limbs six inches from the horizontal, as she lay in her chair. The improvement was permanent and progressive. Another singular feature was that, in spite of her weakness and helplessness, the patient could and did bear with benefit protracted applications. In order to bring the whole body under the influence of the current at one sitting, and at the same time to give the needful attention to the affected muscles and groups of muscles, the sittings were sometimes double the average length.

Improvement in the upper limbs followed improvement in the lower. The extensors and flexors of the arm and forearm soon began to resume their contractility under the faradic current.

January, 1869, the patient had steadily progressed from day to day. Although healthful contractions were not obtained in the muscles below the knee, even under the galvanic current, yet the skin had a less glossy appearance, and the power of motion had greatly increased.

The improvement in the arms, though at first slow, was subsequently more rapid in

\* One of the authors has experienced a precisely similar sensation through the brain, spinal cord, and all the ramifications of the nerves, after an overdose of hasheesh.

the upper than in the lower limbs. By Jan. 1, both the arms and forearms had perceptibly enlarged, as was also shown by measurement. The patient could handle light objects, and was beginning, in an awkward way, to feed herself. She could sit in nearly a natural position in her chair, and when well supported could stand for an instant.

Feb. 1, 1869, the treatment was abandoned, because the patient seemed for the time to remain stationary. At that time she had increased in weight to the extent, it is just to estimate, of twenty-five pounds, although the patient was not weighed. She was able to read short paragraphs, and took her book or paper daily.

On account of the weakness of the peronei muscles of the right leg, the foot had all along exhibited a tendency to turn in. This symptom did not improve.

After the treatment was discontinued, the patient still progressed.

When last seen, August 1870, she had gained from thirty to forty pounds in weight, had nearly full use of her arms and hands, which had regained their full size, and was able to step with assistance, and appeared to be prevented from walking alone only by giddiness. She could read for hours at a time without excessive fatigue.

The improvement in the last few months had been greatly aided by systematic rubbing and movements.

In the above extraordinary case the record was never complete, but the results of treatment were most interesting and remarkable.

*Central Paralysis.*—Central paralyzes are those which depend on some special and distinct morbid condition of the brain, spinal cord, or sympathetic.

Hemiplegia and paraplegia, with their complications, are the more frequent and important manifestations of paralysis of central origin.

When the morbid process is in the central ganglia, the reaction may be either normal, or increased or decreased.

When dizziness is excited by a very mild galvanic current, there is reason to suspect some morbid process within the brain. The diagnosis of the diseases of the brain with which hemiplegia is associated is much aided by the ophthalmoscope, which frequently reveals changes in the optic disk, the retina, the choroid, and the blood-vessels. *Cerebral effusion* may be indicated by congestion or infiltration of the optic disks on the side on which the clot exists; *tumors of the brain* by neuritis, neuro-retinitis, and ischæmia; *softening* occasionally by neuritis or atrophy.

*Prognosis.*—The prognosis of hemiplegia under treatment by electricity is in general much better than has been supposed. Manifestly, everything depends on the nature and seat of the affection as well as on the age and constitution of the patient.

The prognosis is better in proportion as the symptoms are uncomplicated; better in the young and middle-aged than in the old. *Cases that are so thoroughly cured as to leave no marks behind are exceptional.*

*The improvement, however rapidly it may progress at first, usually stops at some point short of a perfect cure.* The majority of cases can be benefited, sometimes rapidly benefited, up to a certain point, after which the improvement cannot be pushed by any amount of treatment. It is furthermore always necessary to bear in mind the liability to other attacks; very many cases are improved at once and rapidly, while with others the progress is almost imperceptibly slow.

In *psychical* symptoms (melancholia, hypochondria, etc.), the prognosis is often quite favorable. A persistence of these psychical complications, even when other symptoms appear to yield, we have come to regard as an unfavorable sign.

In *anæsthesia*, when uncomplicated with other symptoms, the prognosis is remarkably good, even when variously complicated with paralysis of motion or disorder of the cranial nerves, and the anæsthesia may yield, even though its associated symptoms are not affected.

In severe *disorders of speech* the prognosis is not very favorable. They are, however, susceptible of treatment.

In *impairment of nutrition*—the muscular atrophy that so frequently accompanies hemiplegia—the prognosis, especially when the cases have not been too long neglected, is oftentimes exceedingly favorable. After the affected lower limbs have become much reduced, they may by persevering faradization and galvanization be restored to their normal size.

In contractions of muscles and convulsions, the prognosis is unfavorable.

In disorders of bladder and rectum, the prognosis is not very favorable.

In affections of the joints the prognosis is not very favorable.

In cases complicated with hysteria or hysterical symptoms the prognosis is better than in cases not so complicated. In very strong and vigorous persons of coarse organization the prognosis is generally not so good as in the nervous organization.

Other conditions being the same, the prognosis is much better for those cases where the arm is not affected; and when both the arm and leg are affected, the leg is susceptible of the earliest and greatest improvement. The chief difficulty in the hand is usually with the *extensors* and *inter-ossei*, which, being very long and weak muscles, and acting as they do at the worst power of the lever, are the greatest sufferers in hemiplegia, and are very slow to resume their normal functions.

It should always be borne in mind that the tendency of the disease is toward recovery up to a certain extent, and that the improvement which takes place in the early stages, sometimes very rapidly, is partly due to nature and time.

*Electrical Treatment.*—Diseases of the brain of the different varieties are to be treated by both general and localized faradization according to the indications of each case. General faradization is frequently indicated in hemiplegia as in other manifestations of disease of the brain, on account of the general debility of the functions that accompanies and follows an attack of disease of the brain. It improves the general nutrition.

Central galvanization with a very mild current is a method of treatment that is of great service in these conditions. The special form and locality of the galvanization will depend on the supposed locality of the disease.

It is well to use central galvanization alternately with general or localized faradization.

There is little doubt that this method of treatment, when not overdone, acts beneficially on the nutrition of the brain, directly by the passage of the current through the brain, and indirectly through the modification of the cerebral circulation by the irritation of the sympathetic.

It must be confessed, however, that the exclusive use of central galvanization in cranial disorder is far from being satisfactory, and for these four reasons: *First.* With all our improved means of diagnosis it is impossible to fix with anything more than approximate certainty the seat or even the nature of the morbid process in diseases of the brain; hence, all localization of the galvanic current in this or that part of the head must at best be empirical and tentative. *Secondly.* It is impossible to localize the galvanic current entirely in any small portion of the brain. *Thirdly.* Diseases of the brain are usually accompanied and followed by general feebleness that demands constitutional treatment. And *fourthly,* the paralysis will not yield to merely central treatment directed to the seat of the disease, but must be treated itself. In hemiplegia also the spinal cord becomes affected through disease; hence the theoretical indication for galvanization of the spine, or, better still, the entire method of central galvanization.

General faradization, thoroughly used, affects all parts of the brain and the sympathetic at each application, and in addition powerfully and beneficially affects the entire periphery. The improvement which is acquired by the extremities and by all the superficial muscles, and by the viscera especially, under general faradization, we believe, reacts favorably on the brain and aids the reparative process. Our best results thus far have been obtained by the combination of localized faradization of the paralyzed muscles, general faradization, and central galvanization.

In the majority of cases of hemiplegia the muscles are not so badly paralyzed that they will not readily contract during the process of general faradization. Localized faradization with careful and special reference to the motor points is therefore not necessary, and as general faradization acts more or less on the spinal cord, which is secondarily affected, and on the whole system, which in time becomes debilitated, as well as on the paralyzed muscles, it is well oftentimes to use that method in connection with localized faradization or in preference to it.

In regard to the comparative merits of central galvanization, peripheral and general faradization, and localized galvanization of the nerve-centres, in hemiplegia, we should say decidedly that the latter method—localized galvanization of the brain, sympathetic, and spinal cord—is the least important. By itself alone, unaided by other methods, it will accomplish but a little. It comes in very well, however, to supplement other methods, and may be used in connection with them. The full method of central galvanization, however, by acting thoroughly on the whole central nervous system, accomplishes much in hemiplegia, and may carry on the improvement after peripheral and general faradization have finished their work and lost their efficacy.

*Time of beginning Treatment.*—In regard to the *time* of beginning treatment after an attack of hemiplegia, each case must be studied by itself. As a rule, it is better to wait two or three weeks, until the active irritation in the brain has in a measure subsided. The almost universally entertained idea, that it is better in all cases to wait three, four, or six months, until the muscles have been long atrophied and contracted, and the shoulder-joint become perhaps permanently immovable, before beginning electrical treatment, is one of the most serious errors of electrotherapeutics. *If proper caution* be used, it is never necessary to injure the patient at any stage of the disease. Cases that are taken early may be treated at first by exclusively localized faradization; and afterwards, when that has accomplished all that it can and the patient ceases to progress, it may be well to resort to general faradization and central galvanization. Electrization of the facial muscles on the affected side sometimes materially aids the speech, but it may cause unpleasant symptoms, and in the early stages especially should be avoided. *Mild* galvanization may sometimes be used before faradization of the muscles.

*Accessories to Electrical Treatment of Paralysis.*—The treatment of paralysis of all kinds by electricity may be greatly aided by observing the following rules:

1. Thoroughly soak the part with warm water before beginning treatment. When this is done a much feebler current will produce contrac-

tions and the contractions will be more active, and some muscles will readily contract which otherwise would not contract at all.

The skin when dry is, as we have seen (Electro-Physiology, p.108), a poor conductor, and in proportion as it becomes thoroughly moistened in that proportion does its conductivity increase.

2. Relax the muscles when the application is made. The advantage of the observance of this rule is decided (see Electro-Physiology, p.147).

In treating paralysis of the extensor muscles of the hand, for example, flex the hand backward a little and then relax the extensor muscles. In treating paralysis of the peronei muscles of the leg, raise the foot so as to relax these muscles and the tibialis anticus. The muscles of the thigh are most relaxed when the patient is sitting, and most tense when the patient stands. In treating paralysis of the face, draw back the muscles of the affected side toward the ear. Dr. C. E. Detmold has suggested the use of a blunt, curved wire. This wire is placed in the corner of the mouth and the other end is attached by an elastic to a curved wire behind the ear. This contrivance may be worn not only during treatment, but at night, if it be not too disagreeable, and an hour or so during the day.

For keeping the hand raised in lead paralysis, Dr. Geo. Van Bibber, of Baltimore, has devised a contrivance consisting of Sayre's artificial rubber muscle connected by eyelets to elastic bands *attached* by adhesive plaster to the arm above the elbow at one extremity, and at the other extremity to the hand and fingers.

Dr. Van Bibber has utilized the same principle in the treatment of ptosis. In order to hold up the lid he applies a narrow bit of adhesive plaster to the forehead, and to the lid itself.

3. Enlist the mental co-operation of the patient in the treatment. Let him try to move the paralyzed muscles at the *very* moment that the current is applied. Concentration of will alone is sufficient to help paralysis, as has been proved by actual experiment.

4. Passive movements of the limbs at the joints, massage, and manipulation of individual muscles. The joints should be rotated so as to combat the tendency to stiffness and the kneading of the muscles should be carefully and thoroughly performed, massage and passive movements are usually but half done.

5. Apply dry heat to the affected muscles before the electricity is applied, or at any time during the intervals. This can be done in various ways. A good way to bring a paralyzed arm or leg under the prolonged influence of dry heat is to take a common sewer-pipe as sold in the

shops, of a suitable size and curvature, heat it through in an oven, cover it with cloths and let the limb remain in it until the heat is dissipated. In this way not only the forearm and leg, but the whole arm, including the shoulder-joint and the thigh with joint, can be daily subjected to the effect of the prolonged heat. This treatment not only temporarily increases the electro-muscular contractility of the paralyzed muscles, but permanently improves the nutrition both of the muscles and of the stiffened joints. Dr. Charles F. Taylor allows his paralyzed patients to warm their paralyzed limbs in a hot oven arranged for that purpose.

All the above suggestions will apply to the treatment of every form of paralysis.

*Right hemiplegia coming on gradually, with numbness and coldness in right leg ; slight anæsthesia of right hand, and considerable anæsthesia of right leg ; some diminution of electro-muscular contractility in right leg—Gastralgia, insomnia, and great mental depression—Important improvement under general faradization and peripheral galvanization—Subsequent renewed attack.*

CASE LVII.—Hon. Mr. G., aged 52, for many years United States Senator, was referred to us October 19, 1868, by Prof. Austin Flint. During the excitement of the Impeachment Trial the patient, whose constitution was always supposed to be of the strongest, observed a feeling of coldness of the right leg at night. This coldness, however, was not very marked, since his attention was first called to the condition by his wife. One day, while in Congress, and shortly after the delivery of his opinion on the Impeachment, he experienced a slight attack of hemiplegia, which he endeavored to walk off.

Before coming to New York, he had received the very pernicious advice to take vigorous and severe muscular exercise. Acting upon this unfortunate suggestion, he had seriously injured himself at the exhausting labor of chopping wood. He grew decidedly worse, and became exceedingly depressed. Under the advice and medication administered by Prof. Flint he had measurably improved, and at the time we first saw him there was a tendency toward recovery. He complained, however, of persistent insomnia, considerable gastralgia, with indigestion, pain in the lower part of the back, and very great mental depression.

*Electric Examination.*—Slight anæsthesia of right hand ; considerable of right leg ; some diminution of electro-muscular contractility in the muscles above the knee on the right side ; no diminution of electro-muscular sensibility ; the volitional power of the muscles was intact, and the patient could walk a considerable distance.

The case demanded a general tonic as well as merely local treatment, and we accordingly used general faradization daily, or every other day, occasionally making use of galvanization. It was not long before improvement was manifest in all the leading symptoms. He soon began to sleep and to digest better, and was much relieved of the pains in the back. At the end of five weeks the patient abandoned treatment, and so far improved that in the early part of December he resumed his seat in Congress, and during the entire winter continued in the exercise of his official duties.

While under treatment by electricity, he at the same time continued the use of bromide of potassium and other internal remedies, with special reference to the stomach

In the spring following the patient visited Europe, where he was engaged to plead in a case at law. The excitement brought on a new attack, which left him in a condition of despondency, from which, however, he slowly rallied. He afterwards died of another disease.

*Glosso-laryngeal Paralysis (Glosso-pharyngeal Paralysis).*—The distinctive features of this affection are paralysis of the muscles of the tongue, lips, soft palate, and also of the pharynx and larynx. There is difficulty both in speaking (especially in pronouncing certain letters) and swallowing. The saliva dribbles. Food is sometimes forced into the nostrils or larynx. In the last stage there is debility and difficulty of respiration.

*Prognosis.*—This disease is believed to be surely fatal in a few months. Faradization of the pharynx and tongue is, however, of essential service in occasionally relieving the difficulty in deglutition, and also some of the other symptoms.

*Glosso-pharyngeal paralysis of nine months' standing—Great difficulty in speaking and swallowing—Temporary and decided improvement under faradization and galvanization of the affected parts.*

CASE LVIII.—Mr. K., aged 43, a short, stubby, plethoric German, consulted us May 18, 1867, with marked and typical symptoms of glosso-pharyngeal paralysis. His difficulty of speech was very great, and any attempt to read was exceedingly ludicrous. His especial difficulty was in pronouncing certain vowels, as a, u. In eating, particles of food were thrown up in the upper and posterior pharyngeal space, and liquids sometimes were expelled through the nostrils.

The patient referred the beginning of his symptoms to a very severe cold.

Three localized faradizations were followed by manifest improvement in most of the symptoms, and especially in the swallowing.

May 29, galvanization was commenced, and was continued with still further improvement both in speaking and swallowing.

Of the issue of the case we have never heard.

*Glosso-pharyngeal paralysis, with hemiplegia of left side of three years' standing—Chronic pharyngitis—No improvement under a short course of electrization.*

CASE LIX.—Capt. George H., aged 55, consulted us on October 15, 1866, with symptoms of hemiplegia and glosso-labial paralysis. Certain letters, as h, p, he could not articulate, and conversation was a matter of considerable difficulty. He could walk, but needed assistance in ascending stairs or crossing streets.

The accompanying symptoms were in every way discouraging. The patient was partially insane. Naturally kind and genial, he had become excessively irritable and inconsiderate; was at times impatient and violent.

Localized and general faradization, attempted for a short time, proved of no service, and the patient was not encouraged to continue treatment. We afterwards learned that his symptoms gradually became worse, in spite of various hydropathic, equalizing, and other methods of cure that he attempted, and in three years he died.



We do not presume to say that the case that immediately follows was one in which there had been any decided atrophy of nerve tissue, and yet all the symptoms of which the patient complained were of the most persistent and distressing type, and seemed to point unmistakably to structural lesion. If there was *no* decided structural change present in the motor roots of the upper portion of the cord, as the immediate effects of the treatment would seem to indicate, the case affords an instructive illustration of those purely functional conditions that occasionally simulate with such exactness incurable diseases of organic origin.

*Rapid recovery of a supposed case of glosso-laryngeal paralysis of three years' standing under galvanization of the neck and upper portion of the cord.*

CASE LX.—Mr. P., a gentleman aged 45, was sent to us by Dr. James Anderson. Some three years previously the patient had first observed a slight sense of stiffness in the tongue, associated with a feeling of constriction in the pharynx and larynx. Occasionally his speech became thick and hoarse; some words were pronounced badly, and he found it difficult to contract the lips. At such times partial aphonia was present, and when he attempted to converse, the effort was attended with a degree of discomfort if not pain. For several months these symptoms had remained stationary, with the addition only of some little weakness of respiration.

Finally, however, he noticed some difficulty in the act of deglutition, which in the course of a few weeks so markedly increased as to threaten suffocation. He dreaded every attempt at eating, and frequently in the place of his regular meal he would take a considerable quantity of brandy, the stimulating effects of which would often temporarily seem to restore power to the diseased parts. For more than two years this patient had suffered in this way. Although he had unceasingly sought relief, every method that he attempted signally failed to afford the slightest service. On applying for electrical treatment, we at once submitted him to a mild séance of central galvanization, after which a current of somewhat greater strength was as nearly as possible localized in the upper portion of the cord and its motor roots. This accomplished nothing, and as the patient gave evidence of being decidedly unsusceptible to ordinary electrical influences, we attempted at the second séance to localize in the supposed seat of the disease a current from 15 cells, gradually increasing it to 25 cells.

Considerable vertigo with slight spasmodic contraction of the larynx followed, lasting several minutes. On the following day he reported that he was able to eat with markedly increased comfort, and that during the intervals of eating he felt completely recovered. Eight similar applications, but with gradually decreasing strength of current, were followed by complete recovery. In a few months he suffered a slight relapse from which he speedily recovered by a short course of treatment. Two years have elapsed since the treatment, and the patient continues well.

*Paralysis of the muscles of the neck and chin with dysphagia—Not treated.*

CASE LXI.—Mr. L., aged 60, referred to us by Dr. E. R. Peaslee, was paralyzed in the muscles supporting the head and chin; dysphagia was marked, and deglutition was so much impaired that eating was attended with much difficulty.

Our diagnosis was central lesion, the chief expression of which was atrophy of the motor roots. We were permitted to use the galvanic current but about three times.

No benefit was derived, but a further trial might have alleviated the symptoms somewhat.

*Paralysis of Spinal Origin—Paraplegia.*—The exact differential diagnosis of the various morbid conditions of the spinal cord that give rise to paraplegia is sometimes a matter of considerable difficulty, and for these two reasons :—

1. All known morbid conditions of the cord have more or less symptoms in common. In order that any of them may be of special diagnostic value, it is necessary that they should be taken in connection with other symptoms.

2. Many of the morbid conditions of the cord are complicated with each other, and the symptoms must be correspondingly complex. Thus meningitis may exist with myelitis, and the term myelitis itself is a genus of which there are several species. It is difficult to draw the line where irritation ends and congestion begins, and equally difficult to determine at what stage a condition of hyperæmia or congestion becomes a condition of inflammation.

*Electro-Diagnosis.*—In the early stages of spinal paraplegia the galvanic and faradic reaction may be normal, but in the course of a few weeks or months becomes diminished. In most of the cases that consult the physician there is diminished or destroyed electro-muscular contractility.

Electro-muscular sensibility is usually more or less diminished. Electro-muscular contractility is usually much more diminished in the severe forms of paraplegia than in hemiplegia. In cases where the posterior columns are affected electro-anæsthesia may also exist.

*Treatment.*—In hemiplegia, as we have seen, the electrical treatment is substantially the same whatever the nature or seat of the cerebral lesion. Similarly in paraplegia the treatment, so far as electricity is concerned, is the same, whatever be the nature of the spinal lesion on which the paraplegia depends. Spinal paraplegia should be treated by galvanization of the spine, and peripheral faradization or galvanization; to depend on one method solely is unnecessary. In paraplegia the electro-muscular contractility is frequently so much diminished that it is necessary to give particular attention to the motor points in order to produce contractions. Whether general faradization and central galvanization be employed will depend on the general condition of the patient. In the early or subacute stage the sances should be short; in the chronic stage the

séances may sometimes be more protracted. In many incurable cases the general tonic effects of general faradization alone are of very great service.

*Prognosis.*—Nearly all cases of spinal paraplegia can be benefited by electrical treatment, but very few can be entirely or permanently cured. We may look for perfect recovery in some cases that are taken early, and in cases that depend on hysteria, congestion of the cord, or exhaustion. Cases of myelitis, meningitis, and non-inflammatory softening are, as a rule, but little benefited, although they may sometimes improve quite rapidly under electrical treatment up to a certain point.

In cases of reflex paraplegia, however, the faradic current is exceedingly useful in preventing the ill effects of rest on the paralyzed muscles and materially hastens recovery.

*Peripheral Paralysis.*—A true peripheral paralysis manifestly excludes all lesions or influences of a central origin. The cause must be sought for in some portion of the nerve-tract after it has emerged from the bones that enclose the nervous centres.

The principal causes of peripheral paralysis are :

1. *The action of cold on the superficial distribution of nerves.*
2. *External injuries.*
3. *Pressure on the nerve from morbid growths, etc.*
4. *Destruction of a nerve by carious bone, etc.*

*Facial Paralysis.*—The most prominent form of peripheral paralysis is that of the seventh pair of nerves. The symptoms of facial paralysis vary not only as its cause is central or peripheral, but also according to the portion of the nerve affected. Paralysis of the seventh pair without coincident paralysis of an arm or leg seldom results from cerebral hemorrhage. It may occur, however, but it may be readily distinguished from the peripheral form of the affection. *In complete facial paralysis of peripheral origin the orbicularis palpebrarum muscle is paralyzed, and the eye cannot be entirely closed; while if the cause is central this muscle is, as a rule, unaffected, and the eyelids can be brought together.* In some exceptional cases a certain lesion may paralyze the orbicularis muscle, while occasionally, in peripheral facial paralysis, the nerves that supply the muscles of the eye may escape, thus leaving it free to close. The fact that in facial paralysis of central origin the electromuscular contractility is unimpaired, while if the nerve itself is the seat of the injury the muscles refuse to respond to the faradic current, materially aids us in diagnosis.

*Electro-Diagnosis.*—In facial paralysis of a *peripheral* origin, the *farado-muscular* contractility is usually diminished or lost; *galvano-muscular* contractility may be *increased* or normal; though in some cases it may be diminished, it is rarely lost. Facial paralysis is one of the conditions in which the difference between the two currents, in their power of producing contractions of muscles, is typically shown. The galvano-muscular contractility sometimes becomes so much increased that when the farado-muscular contractility is entirely abolished, the diseased muscles respond to a much feebler galvanic current than is necessary to produce contractions on the healthy side. As the muscles resume their normal condition under treatment, the galvano-muscular contractility diminishes.

*Prognosis.*—The prognosis of facial paralysis of a peripheral origin is generally very favorable. Few forms of paralysis yield so surely as this, provided the electrical treatment be used with sufficient perseverance.

*Treatment.*—Facial paralysis should be treated by localized faradization and galvanization. When the muscles fail to respond to the faradic current it is of but little worth to use it; it is far better to depend on the galvanic current. In this disease the current-reverser electrode is exceedingly convenient. A current just sufficient to produce contraction of the muscles is better than stronger currents, and short applications are preferable to long ones.

*Facial paralysis from exposure to cold—Loss of contractility to faradic current—Improvement under the galvanic current.*

CASE LXII.—Miss P., a stout, vigorous young lady of 15, was sent to us by Dr. F. Elliot, to be treated for paralysis of the seventh pair, on the left side, caused by exposure to a draught of air two months previous. The paralytic symptoms came on suddenly and in full force immediately after the exposure, and at first she experienced considerable difficulty in speaking.

She gradually became so accustomed to the abnormal condition of her lips and face that she was able to converse almost as clearly as before; but the improvement in the condition of the paralyzed muscles was very slow, and at the time she came to us the affection appeared to be almost stationary. At the time she received the first application at our hands (Aug. 1, 1862), she presented most of the usual symptoms of paralysis of the seventh pair.

Her mouth was drawn over towards the healthy side so violently as to produce considerable deformity when she laughed or conversed, and even when she smiled. When she attempted to frown, the left brow remained as smooth as that of a child.

Her left eye rolled up, and when she attempted to close it, the lids would not approach nearer than one-quarter of an inch to each other. A powerful faradic current, localized in the affected muscles, produced very feeble imperfect contractions; while on the sound side a very mild current, applied with the hand, produced active contractions of all the principal muscles. The patient was so well in all other respects,

that we decided to use only partial or localized electrization over all the muscles on the left side of the face. Two vigorous applications made in this way, one electrode being placed firmly in front of the ear, and the other passed over the ramifications of the seventh pair, as well as over the individual muscles, did not seem to increase to any appreciable extent the electro-muscular contractility, and accordingly we resolved to adopt an entirely different method of warfare.

The next time we localized the galvanic current through the left side of the face, and with the best results. Contractions of the paralyzed muscles were at once produced that were as vigorous and as natural as those caused by the faradic current on the healthy side, and by a current that had no effect on the healthy side.

The patient began at once to improve, and after ten visits, distributed over a period of six weeks, she was dismissed as approximately cured. There still remained some deficiency of action of the muscles concerned in frowning and in winking, but the expression of her face, both in repose and in conversation, was normal.

The interesting points in this case are these :—

*First.*—The galvanic current produced contractions and wrought a cure when the induced or faradic utterly failed.

*Second.*—The paralyzed muscles were at first brought to contraction by a galvanic current *that had no effect whatever on the muscles of the healthy side.* As the patient improved, however, it became necessary to use a stronger galvanic current in order to produce the contractions. Towards the close of the treatment, the muscles of the paralyzed side began to respond to the faradic current.

That the faradic current may sometimes work well in facial paralysis is shown by the following case :—

*Partial paralysis of the right side of the face, with contraction of muscles following neuralgia—Approximate recovery under localized faradization.*

CASE LXIII.—Miss J., aged 40, came to us in the early part of September, 1868, to be treated for a facial paralysis of a peculiar character. Her face was drawn to the right side, so that her features were very much distorted. We at first supposed, and very naturally, that the case was one of paralysis of the seventh pair of the *left* side, but a more careful examination led us to modify our diagnosis.

Her history was as follows: Several years before, while occupied in a day and night attendance at the bedside of a sick friend, she was suddenly attacked with severe facial neuralgia of the *right* side, that continued to annoy her for two months. The disease then abated, but since that time she had been frequently harassed by persistent numbness in the right arm and hand.

On localizing a strong faradic current through the muscles of the *left* side of the face, powerful contractions were excited. On the *right* side no such effect could be produced.

Furthermore her right eye was nearly closed, owing to a partial ptosis, and while she could easily frown and corrugate the left brow, the right was entirely smooth and expressionless. It was very evident, both from the history of the case and from symptoms at the time, that the *right* side was paralyzed, and not the left, as at first ap

peared, and that the face was drawn towards the right by the contractions of the *muscles following the paralysis*.

Trousseau has described this condition so accurately that we quote his own language as it appears in the translation of Bazaire.\*

After relating the symptoms of a patient suffering from paralysis, he says: "If left facial paralysis was thought of at first sight, the depression of the lower lid, and the less marked expansion of the nostril on the right side, were already sufficient to cause a modification of the diagnosis. But when the patient attempted to move that side of her face there could no longer be any hesitation, and it became manifest that it was the right side which was affected. When she spoke, and still more when she laughed, her face was pulled with force to the left, the upper lip and the ala nasi on that side going obliquely upwards, and the labial commissure being drawn with considerable energy upwards and outwards. When she attempted to blow, her left cheek swelled and her mouth remained closed on that side, whilst her right cheek was flaccid and her mouth opened out a little on that side. Besides, she could not shut her right eye, however much she tried."

In this case we used only the faradic current, localizing the electricity as nearly as possible along the course of the portio dura and its ramifications. To accomplish this the small positive electrode was pressed firmly on the point where the nerve emerges from the temporal bone, while the negative was moved along its various terminal branches.

No particular results were obtained from the first application, but during the second visit slight contractions were produced on the right side, and it was then noticed that the eyelid did not fall so low as before.

In the course of a few days the patient again visited us, when the improvement was quite marked. There was considerable relaxation of the contracted muscles, and the electro-muscular contractility was readily demonstrated. At the fourth visit, which occurred about two weeks from the commencement of treatment, the ptosis was hardly noticeable, and the power of corrugating the occipito-frontalis on the right side was perfect. There still remained, however, some distortion of the features, owing to the obstinate nature of the muscular contractions, and, although she subsequently received quite a number of applications, the contraction was not so entirely dissipated as were all the other symptoms.

*Facial paralysis existing three weeks—Immediate effects of faradization.*

CASE LXIV.—Mr. C., aged 35, a patient of Dr. Joseph Worster, had been afflicted for three weeks with paralysis of the seventh pair, in the right side.

The patient complained of a peculiar tingling and occasional numbness in the hands and feet that we regarded as an indication of slight central disturbance. In all other respects his health was excellent. A local application of the faradic current resulted in immediate benefit, and two more sances were followed by approximate recovery.

*Paralysis from Pressure and Cold.*—Paralysis sometimes occurs from pressure on the nerves of the arm during sleep, and most frequently in persons who are intoxicated.

Paralysis of the arm may also arise from the pressure of a board or any other hard object under the arm. It may also be caused, like facial

\* Lectures on Clinical Medicine, Part II., p. 322.

paralysis, by exposure to cold. Paralysis may arise also from the pressure of the foetus in parturition.

All these forms of peripheral paralysis may be treated by electricity, preferably by the galvanic current, and with curative results, unless the nerve be too severely injured.

*Paralysis of muscles of right thigh ; apparently produced by exposure to cold—Anæsthesia—Improvement under galvanisation—Increase in size of limb.*

CASE LXV.—Miss F., aged about 20, first observed a slight pain and soreness in the muscles of the right thigh, that readily yielded to a few applications of the faradic current. Five months subsequently, after several hours' exposure to cold and wet, she experienced considerable pain in the right limb, and also a marked degree of stiffness, that disappeared temporarily after walking a few times around the room.

In a few days the pain extended to the hip and involved the whole limb, which soon became completely paralyzed, and for two weeks she suffered excessive pain both day and night. Three months later, when it was decided that the patient should be treated by electricity, she was able to move about the house with the aid of crutches, although the limb remained almost perfectly powerless.

The anæsthesia over the quadriceps muscle was very decided, the æsthesiometer producing two impressions only when its points were separated four inches, and the electro-muscular contractility was entirely absent in all the external or surface muscles of the thigh and in a portion of the leg. The thigh had atrophied to the extent of an inch and one-half.

Ten applications of the faradic current entirely dissipated the anæsthesia, so that it was necessary to separate the æsthesiometer but three-quarters of an inch in order that two impressions might be received.

The same current partially restored also the electric contractility of the diseased muscles ; but it was not until a *galvanic current* of considerable intensity was employed a number of times, that they responded healthfully to its influence.

The faradic current was again resorted to and persistently used for several months.

The limb gradually increased in strength, so that she was able to walk readily with the aid of a cane. It increased also in size, so that around the thigh it measured but one-quarter of an inch less than the sound limb. Time alone can tell whether she will ultimately regain complete control over the diseased member.

*Complete paralysis of the flexors and extensors of the wrist and fingers, caused by pressure—Cured by three local applications of the faradic current.*

CASE LXVI.—Mrs. P., aged 30, was suffering from complete paralysis of the extensors and flexors of the wrist and the right arm. Eight weeks before she had held her little child in her arms all of the day. The right arm was of course used the most. In the evening she fell asleep in a rocking-chair, with nearly the whole weight of the child resting on the right arm. In the course of an hour she awoke, to find the wrist and fingers paralyzed. No improvement had been manifest in the condition of the parts up to the time we saw her.

The tissues below the wrist were decidedly anæsthetic, but electro-muscular contractility was little impaired. Three local applications of the faradic current alone, in

the course of five days, dissipated the numbness, and so improved the members that she could with ease move the fingers and wrist in every natural direction. The recovery became complete in a week or so without further treatment.

*Calorific Paralysis.*—Under this head Benedikt records a case of paralysis caused by the contact of glowing hot iron with the skin, at a point near the radial nerve. The nerve was not directly injured, but paralysis with anæsthesia ensued. The patient recovered after a number of sittings. Both galvanic and faradic currents were employed.\*

*Reflex Paralysis.*—Under this head are included those peripheral paralysees which arise by reflex action through the central nervous system, from some remote part of the body. Some of the cases of general paralysis of all the extremities are of this nature.

Paralysis that arises by reflex action may remain long after the morbid condition that caused it has entirely disappeared.

*Treatment.*—Localized faradization or galvanization is required in this form of paralysis. This treatment should be directed not only to the paralyzed muscles, but also in some cases to the diseased part from which the paralysis is reflected. In doubtful cases, general faradization and central galvanization may be tried.

*Prognosis.*—This is much more favorable than in paralysis that directly proceeds from organic disease. Everything depends on the nature and locality of the irritation.

*Typical case of complete reflex paralysis of the seventh pair on the right side of the face, following severe neuralgia of the fifth pair on the same side.*

CASE LXVII.—The patient, a lady aged 30, some weeks previously, had experienced, in the fifth pair, an attack of sharp shooting pains of far more than ordinary severity. This was followed in the course of twelve hours by symptoms of facial paralysis, which gradually increased until the loss of power was almost complete.

The muscles responded to the influence of faradization, but there was a manifest decrease of the electro-muscular contractility. Three applications of the faradic current to the affected side completely restored the contractile power of the muscles, and three similar applications removed the paralysis.

*Reflex paralysis of the left arm, apparently from neuralgia of short duration—  
Recovery under localized and general faradization.*

CASE LXVIII.—Mrs. W., aged 31, consulted us February 1, 1867. She was suffering from general neuralgia, which was especially localized in the left arm. Appetite, digestion, and sleep were all poor.

There was paralysis nearly complete of the left arm. We began treatment by general and localized faradization. In one week, after three sittings, the paralysis disap-

\* Op. cit., p. 480.



peared. Treatment by general faradization was subsequently continued, for the purpose of raising the tone of the system.

*Reflex paralysis of five months' standing—Approximate recovery under fifteen applications of the faradic current.*

CASE LXIX.—Miss —, aged about 30, an inmate of the N. Y. State Woman's Hospital, was afflicted with uterine displacement, and finally was prostrated by a severe attack of cellulitis.

During and after recovery from this illness the patient complained of anæsthesia and tingling in both feet, together with a decided loss of motor power. These symptoms were persistent, and for five months the patient was able to walk but very short distances and only with great difficulty.

On examination with the faradic current it was found that the electro-muscular contractility was somewhat impaired. Faradization of the lower portion of the back, the loins and the legs was employed, with the observed effect of at once increasing the contractility of the muscles.

Twelve applications so improved her condition that she succeeded in walking two miles without suffering extraordinary fatigue.

## CHAPTER XXI.

### LOCOMOTOR ATAXIA—POSTERIOR SPINAL SCLEROSIS.

IN regard to posterior spinal sclerosis we have these remarks to offer :

1. The great exciting causes of the disease are exposure to wet and cold, mechanical injury, and syphilis. It is a fact not thoroughly appreciated by the profession or by the people, that it is as possible to take cold in the cord as in the lungs. Cold in the cord manifests itself just as cold anywhere else manifests itself,—that is, by congestion ; and if the colds are repeated, the congestion becomes a fixed condition that is not easily resolved, and in time may go on to the condition known as posterior spinal sclerosis, or locomotor ataxia.

The connection between this structural lesion of the cord and exposure to wet and cold is not always directly apparent, is but rarely suspected by the patient, and almost never inquired into by the physician, partly because of its remoteness, and partly because the professional mind, at least, has been diverted in the direction of sexual excess as the one great cause of ataxia.

The mechanical injuries that most frequently give rise to sclerosis of the cord are severe blows and falls, or the shock of accidents of almost any kind. It is not necessary that the injury, whatever it may be, should be received on the spine or head, in order to cause symptoms of ataxia. A violent concussion from any injury that is directly felt on the arms or legs may have the same effect as a direct injury to the back.

2. The cord is predisposed to take cold by any causes that tend to exhaust it. Among the more prominent of these causes are long marching or violent and wearying muscular exertion of any kind, especially of the sort that draws heavily on the lower part of the cord, excessive intellectual exertion, and sexual excesses. The two latter predisposing causes, excessive intellectual exertion and sexual excesses, operate far less frequently than the purely physical causes.

3. In regard to the supposed influence of sexual excesses on this

disease, the profession must revise its opinion. That sexual excesses constitute an important factor in the causation of nervous diseases must be admitted, but it is not structural so much as functional diseases that they excite.

One plausible reason for suspecting that sexual excess is the cause of ataxia is found in the unnatural sexual desire that so often precedes the ataxic symptoms. The increase of desire naturally calls the attention of the patient to the sexual organs, and almost compels a certain amount of abuse; and when questioned concerning his habits, it is no marvel that he recalls and confesses his recent experience in this respect. Now, this increase of sexual desire is often, if not always, the effect of spinal congestion, by which the cord is rendered excessively active; it is a sign, not of health, but of disease. It is not, however, nor is the abuse which it invites, the cause of the degeneration of the cord into which congestion leads.

The most, then, that can be said of sexual abuse in its relation to ataxia, is that, by weakening the cord, it may in certain temperaments prepare the way for colds, mechanical injuries, or perhaps for syphilis, to enter in and take possession.

4. It is more frequent, so far as we can learn, in the North than in the South; cold, damp climates favor its development. In the early stages, long residence in tropical or subtropical regions is worthy of trial.

5. It is very often complicated with congestion and sclerosis of the anterior column. The neuralgic pains, of which so much is said, do not appear in much more than half the cases. We are not yet able to say whether they are a good or a bad symptom. One thing is sure, the worst and most obstinate cases we have yet seen had no neuralgic pains. Another point equally true is, all the characteristic neuralgic pains may exist in those who never have ataxia.

*Electro-Diagnosis.*—The electro-muscular contractility, or at least irritability, may be normal or increased. This fact distinguishes locomotor ataxia from ordinary paralysis of motion depending on anterior or spinal sclerosis, in which the electro-muscular contractility is usually diminished. The electro-muscular contractility may, however, be diminished in certain forms and stages of posterior spinal sclerosis, or when complicated, as it may be, with anterior spinal sclerosis or with hysteria or general congestion of the cord, or of the membranes.

*Prognosis.*—The prognosis of this disease under electrical treatment alone, or in combination with drugs, may be thus generally stated: A very small proportion of cases apparently recover; a considerable

number are very greatly benefited in all the leading symptoms; about the same number are but slightly benefited; and in a few cases absolutely nothing is accomplished.

The proportion of absolute cures is so small that there is a natural temptation to doubt the diagnosis or pathology of any reported cure. The cases that are brought on by mechanical injury, especially by concussion, offer the best prognosis; and this is true, we believe, of other nervous disorders. The explanation would appear to be that the disease excited by concussion is of a temporary, and comparatively transient, character, and the character of the lesion is far less severe than in those cases that come on slowly, through long years of incubation. In our observation the most satisfactory improvement has been in those cases of ataxia that were brought on by concussion. This is also true of paralysis in general, excepting, of course, those cases where the spinal cord is directly and seriously injured.

Most of the published statements in regard to the prognosis of the disease under electricity, as indeed under any other form of treatment, must be received with great caution. Many of the physicians who report the cases have perhaps never before seen a case where they made the diagnosis of ataxia, and in the instance that they publish there is much probability of deception; and this probability is increased if the patient perfectly and permanently recovers. Hysteria comes in to complicate the diagnosis, and some of the reported cures have been, without doubt, of an hysterical character. Spinal congestion is very often mistaken for spinal sclerosis; the symptoms run into each other, and the former in some cases leads to the latter. But spinal congestion is relievable and curable, while spinal sclerosis is rarely so. Some of the supposed cures have been very likely simply remissions in the course of the disease.

*Treatment.*—Ataxia may be treated electrically by a combination of several different methods of electrical application: Galvanization of the spine, central galvanization, and general faradization when cerebral disturbance or general ataxia of the nervous system appear; galvanization of the cervical sympathetic, and peripheral faradization with sponges and the metallic brush. All these various applications may be made with weak or strong or medium currents, according to the wants of each case.

We have found good results from simply treating the leading symptom,—the anæsthesia,—without any special reference to the cord. We do this by means of the metallic brush, or by a finely-pointed metallic electrode, making the application over the feet, legs, arms, and all parts

of the body that are anæsthetic. The end justifies the means. We have found more good, in some cases, from this method than from galvanization of the spine and all the other methods combined. When the anæsthesia is profound and permanent, currents of great strength are sometimes not only not disagreeable, but positively agreeable.

In recommending this method we do not recommend exclusive reliance upon it; it is to be used in alternation with the other methods of which we have spoken. It should not be forgotten that the reflex effect of powerful peripheral faradization on the cord may be of greater service than galvanization of the spine.

*Posterior spinal sclerosis—Concussion of the spine complicated with attacks of aphasia and weeping—Very unusual improvement under galvanization of the spine and nitrate of silver.*

CASE LXX.—Dr. N., a medical gentleman, over 70 years of age, was brought to us November 9, 1872, by Dr. Corey. About six months before, the doctor undertook to get on a street-car, but, the iron support being loose, he slipped and fell on his hip and leg, and for this he was treated surgically. He was laid up with the injury to the leg and hip for some weeks. Certain nervous symptoms also began to appear after a few weeks, but they were not referred to any injury of the cord, and spinal sclerosis was, very naturally, not suspected. Dr. Corey had made the diagnosis of degeneration of the cord before bringing him to us, and this diagnosis corresponded with our own. The patient had a stiff and uncertain gait, and could not turn round quickly without falling, nor stand still when his eyes were closed. A strange complication was occasional attacks of utter inability to speak, accompanied with suffusion of the face and shedding of tears. These came on under any special excitement, and lasted from one to five minutes.

The anæsthesia and *analgesia* of the lower limbs were profound, and electro-sensibility was but slight; but there was no loss of electro-muscular contractility, and no motor disturbance whatever. There was also a deficiency of the sense of pressure, as indicated by the *piesmeter*. At night there was great pain in the back, with a sensation of numbness that often compelled him to rise and walk the room.

As the patient was entirely well at the time of the accident, and as the symptoms of sclerosis followed or at least began to appear a few weeks after the accident, and as there was no evidence of exposure of any kind, it was clearly a case of *traumatic ataxia*.

The case was subsequently brought into court, in order to collect damages of the railroad company, and was decided in favor of the patient. Being called upon to testify, we gave it as our opinion that the disease from which the old gentleman suffered was of so grave a character that he would never recover, but would be a great sufferer until he died.

We subsequently treated the above patient by mild galvanization of the spine, and nitrate of silver, and in the course of a month he began to improve, and, what is more remarkable, the improvement continued. He did not fully recover, but was able to resume active labors.

## CHAPTER XXII.

### PROGRESSIVE MUSCULAR ATROPHY.

*Electro-Diagnosis.*—In cases of progressive muscular atrophy the electro-muscular contractility is either diminished or destroyed. Electro-muscular sensibility is usually diminished. Various changes in muscular irritability may take place during the progress of the disease.

*Reflex contractions* occur in muscular atrophy. *Diplegic contractions* also appear in this disease. These facts, taken in connection with the history of the case, the atrophy, the fibrillary contractions, swellings, and ankylosis in the bones and joints, the anæsthesia and the neuralgia, make up the diagnosis. Diplegic contractions were first observed in muscular atrophy by Remak; they have since been observed in hysteria and other irritable conditions.

The disease does not always exist alone; it may be complicated with locomotor ataxia, with paralysis of the cranial nerves and other disorders of the brain.

*Prognosis and Treatment.*—Our better and increasing knowledge of the possibilities of electro-therapeutics fortunately enables us to modify to some extent the prognosis in this disease. That the prognosis is grave cannot be denied, but by persistently following out the treatment that of late years has proved so successful, we confidently assert that not only may the disease be arrested far more frequently than in the past, but that in not a few instances the nutrition may be so far improved as to amount to approximate recovery.

In no other forms of disease does it seem to us so important that especial emphasis should be laid on the electrical treatment as in those of the so-called progressive character. In many of the phases of paralysis, in the neuralgias and in most forms of local and constitutional disturbance where the indications call for electricity, other remedies as well have their uses, and in many instances are even of greater service.

When we advance, however, to the consideration of those ominously progressive disorders, ataxia and muscular atrophy, we recognize the fact that, with the exception of those cases which depend on a syphilitic

taint, our ordinary remedies exercise but little control over their progress. We have therefore almost in despair turned to the therapeutics of electricity in these diseases, and although it has failed by far to accomplish all that could be desired, it has yet proved to be more efficacious than is generally credited. In some cases it certainly arrests the disease.

As a rule we alternately make use of central galvanization in its most thorough form with faradization and galvanization of the affected muscles.

Persistent faradization of individual muscles has been alone recommended by Duchenne,\* and among others who have reported recoveries by this simple and single method might be mentioned Dr. Alex. P. Fiddian.

The case † that he details was treated by that form of electricity generated by the old-fashioned magneto-electric machine, and although the authenticity of the statements cannot be doubted, yet a knowledge of the combined experience of those who have accomplished most in electro-therapeutics must confirm us in the assertion that in order to achieve the best results, both currents must be used and the applications directed to the nerve centres as well as to the affected muscles.

*Progressive muscular atrophy of muscles of the right hand, three years' standing—Pain in back—Numbness, and coldness, and neuralgia of the arm—Disease of the skin—Arrest of the disease under galvanization of the spine and peripheral faradization.*

CASE LXXI.—Mr. N., a gentleman of middle life, was brought to us by S. J. Holley, November 14, 1870. The patient, who had a strong constitution, for three years had been suffering from atrophy of the muscles of the ball of the thumb of the right hand. The disease had been gradual in its onset, and very gradual in its advance, and by various treatment—medicines and faradization of the muscles—had been more or less modified. The atrophy was preceded by pain in the back in the region of the third dorsal vertebra. This spot we found to be tender on pressure, and also tender under the electric current. A galvanic current applied to the tender spot caused at once *a sensation in the affected hand*. There were in the hand persistent coldness and great numbness, with anæsthesia, and also impairment of the sense of pressure as determined by examination with the piesmeter, and there was enfeeblement of the sexual power. The coldness and numbness were first *felt six years before* in the track of the ulnar nerve; the pain in the back appeared five years before, and two years after that the muscles of the hand began to atrophy. At one time there had been evidences of an acute, or rather subacute, congestion of the cord, with the symptoms of numbness of half the body on the right side; anæsthesia of the rectum, so that the fæces were passed unconsciously, and severe neu-

\* De l'Electrisation Localisée, p. 702.

† Med. Times and Gazette, July 20, 1872, p. 66.

ralgia of the arm—these symptoms lasted one month. The first (and not very strong) application of the galvanic current caused insomnia that night; pain in abdomen, and mental depression, and anæsthesia of the rectum; one day following treatment he felt a sensation in his back, as though some one had suddenly and severely struck him from behind; gradually he became accustomed to the applications, which were made milder and shorter, and began to get better. There were less insomnia and better appetite, less pain and more warmth in the hand and arm. During the treatment, which lasted several weeks—about twenty applications—a *pruriginous eruption appeared on the back and shoulders, with great itching, with which came great relief of the pain in the spine.* The itching of the prurigo was itself relieved by the galvanic current. The disease was, to all seeming, arrested, although the atrophied muscles did not return to their normal condition. Eighteen months after the close of the treatment we met the patient. He was in excellent health; although the hand was still considerably shrunken, the sexual power had returned, and he had but recently married, having previously lived a bachelor, and he was in most excellent spirits.

The features of most interest in the above case are :

1. It seemed to show the central origin of progressive muscular atrophy. Long before the muscles of the hand began to atrophy there was evidence of spinal congestion at or near that part of the cord whence issue the nerves to supply the arm. For several years these symptoms had been existing before the atrophy was observed.
2. The fact that, when taken early, progressive muscular atrophy, grave as the disease is, may be arrested by galvanization of the nerve-centres.
3. The apparent relation of the pruriginous eruption and the morbid state of the cord. When the eruption appeared with severe itching, the patient at once improved, and then the eruption was itself relieved by the galvanic treatment (see chapter on Diseases of the Skin).

*Progressive muscular atrophy of several years' standing—Approximate recovery under persistent treatment by general and local faradisation and spinal galvanization.*

CASE LXXII.—Mr. D., aged 44, came to us with symptoms typical of progressive muscular atrophy. These symptoms had been developing for over two years. The thenar and hypothenar eminences of the right hand, together with the mass of interossei muscles, were so wasted as to render the hand nearly useless. The outer muscles of the left hand were also somewhat wasted, so that the little finger of that side was fast becoming powerless. On localizing the faradic current in the affected muscles of the right hand it was found that there was some degree of electro-muscular contractility in all of them.

Up to a few days before, the patient had been unaware of the nature of his complaint, and on learning its true character, he expressed his readiness to undergo prolonged treatment. In addition to the symptoms above stated, he complained of weakness and stiffness of the limbs, together with some want of co-ordinating power.



Once a week the patient was submitted to general faradization, and three times a week to galvanization of the spine, and faradization of the affected muscles. Spasmodic contraction occasionally occurred in the flexor muscles of either arm and hand, and these contractions were always aggravated if the faradic current was applied to these muscles, while a mild continuous galvanic current afforded great relief. The above treatment was continued uninterruptedly for four months, when it could readily be seen that there was an appreciable increase in the size of the atrophied muscles, especially those between the thumb and index finger. He was again able to write with considerable readiness, something which he had not attempted for several months. His limbs had gained markedly in strength, and he seemed approximately well.

*Progressive muscular atrophy with paralysis of the extensor muscles of the hand—Decided relief under local faradization and galvanization of the sympathetic—Diplegic contractions.*

CASE LXXIII.—A gentleman, aged 40, was sent to us by Dr. J. J. Crane. There was decided paralysis of the extensor muscles of the right hand, with such marked atrophy of the muscles at the base of the thumb as to cause both the thenar and hypothenar eminences to stand out in bold and angular relief. Spasmodic contractions of the flexor muscles occasionally occurred, and he was annoyed by sharp neuralgic pains in the affected part. These symptoms were first noticed somewhat more than a year previously, and the apparent cause was a violent jerk that he had received about that time. The patient was treated by galvanization of the sympathetic, and faradization of the affected muscles, and the result, after some twenty sésances, was approximate relief of all pain and tendency to spasmodic contractions; the grasp became stronger, and the patient was again enabled to write with some degree of readiness. The treatment was not continued sufficiently long to enable us to test in this case the power of faradization to increase the muscular tissue.

We were enabled to excite in this patient the so-called diplegic contractions of Remak.

*Muscular atrophy of three years' standing—Increase in size of the atrophied muscles, and approximate relief of associated symptoms—The patient still under treatment.*

CASE LXXIV.—In the case of a gentleman of 50, who at the date of writing is still at our hands receiving treatment, that has already extended over several months, the benefit derived has been of the most decided character. The first symptoms of the disease were observed three years prior. When we first saw him, there was very marked atrophy of the muscles of the right hand and to a less extent of those of the left; this atrophy, moreover, was making appreciable progress from month to month. There was paralysis of the index finger of one hand and the little finger of the other; sudden spasmodic contractions of both hands were frequent and annoying, and there was an utter inability to write. Up to this time the treatment by central galvanization combined with faradization of the atrophied muscles, galvanization of the flexors, with occasional sésances of general faradization, have vastly improved the patient in every symptom. The nutrition has been so far improved as to show an appreciable increase in the size of the affected muscles. There has been an approximate recovery of the paralyzed fingers; spasmodic contractions no longer annoy him, and he enjoys considerable facility with the pen.

*Progressive Myo-Sclerotic Paralysis (Progressive Muscular Hypertrophy), Pseudo-Hypertrophic Paralysis.*—This disease of childhood was first described by Dr. Edward Meryon, in a paper read before the Royal Medical and Chirurgical Society, December, 1851. A case was subsequently reported by Dr. T. King Chambers, in the *Medico Chirurgical Transactions*, 1854. The disease has been observed in two, three, and four children of one family. The disease has been systematically studied by Duchenne, who was the first to set it before the profession as a distinct disease. The *symptoms* of this affection in the first stage are weakness in the lower limbs and flexion of the toes; in the second stage, *increase in size of the muscles of the legs*—especially of the calves, of the back, and of the gluteal muscles; in the third stage, extension of the disease, muscular atrophy, exhaustion, and death.

*Electro-Diagnosis.*—Farado-muscular contractility usually diminished; galvano-muscular contractility may be either normal or exaggerated; electro-muscular sensibility is sometimes diminished, sometimes normal.

*Prognosis.*—The patient is pretty sure to die in the course of a few years. In the second stage the symptoms may remain stationary for a long time. Benedikt was able to improve a case of two years' standing by galvanization.

*Treatment.*—Faradization and galvanization of the affected muscles, central galvanization, and galvanization of the sympathetic, should all be tried in succession or alternation.

## CHAPTER XXIII.

### RHEUMATISM AND GOUT.

**RHEUMATISM** is a disease for which electricity, by various methods of application, has been employed, with more or less success, from the early periods of the history of electro-therapeutics. Next to paralysis, it is perhaps the disease in which the original experiments of electro-therapeutists were most frequently conducted; and for the reason that (like paralysis) it is so frequently obstinate to ordinary remedies.

*Treatment.*—*Being a constitutional disease, it demands constitutional treatment.* The best results are obtained by general faradization, combined with faradization or galvanization of the affected joints. To confine the treatment to the affected joint is unphilosophical, and usually more or less unsatisfactory, for the obvious reason that it attacks merely a local symptom, which at any time may be transferred to other and remote parts of the body. The true method is to lay the axe at the root of the tree by making the applications general, so as to bring the whole system under the influence of the current. This treatment sometimes causes increase of the flow of urine, and almost always more or less exhilaration, and relief of the pain. Special attention should be given to the parts which are chiefly affected, and the swollen joints should be treated by mild and steady faradization or galvanization. Where in the acute or subacute forms the immediate effects are agreeable, it is probable that continued treatment will be of service. For the local treatment the galvanic and faradic current may be used alternately.

The effect of the current on the inflamed joints is to relieve the pain, reduce the inflammation, and, where effusion has taken place, to cause absorption. Absorption may be caused by both currents, in some cases more powerfully by the galvanic. If the currents are used too strong or too long, the pain and inflammation may be increased. For applications to very sensitive and painful joints, the *positive* pole is preferable (see p. 281). For rheumatic callosities and ankylosis, *very prolonged* local applications of the galvanic current may be tried.

*Prognosis.*—In presenting the prognosis of rheumatism great stress

must be laid on the distinction between the *chronic, subacute, and muscular varieties*.

During our earlier investigations in electro-therapeutics we treated perhaps as many cases of rheumatism as of any one class of disease. The apparent results of treatment by electrization in many cases of muscular, and in a number of cases of the acute, subacute, and chronic varieties of articular rheumatism, excited our enthusiasm, and led us to hope that a remedy had been found that would prove very generally and powerfully remedial in all forms of this disease. Further experience and investigation compel us to declare that we are not to expect such rapid and decided benefit from electrization in the worst cases of *chronic articular rheumatism* as we at first supposed.

The most uniform results are obtained in the muscular form; the next best are the subacute and acute, and the least satisfactory of all in the chronic stages.

A good opportunity to note the immediate effect of electrization is afforded in those cases where the disease is of such severity as to render any of the muscles of the body almost if not quite powerless.

*Rheumatic paralysis—Decided relief under general faradization.*

CASE LXXV.—The sufferer was a little boy, who for several months had been afflicted with both acute and chronic muscular rheumatism. The sterno-cleido-mastoid-eus, and the platysma-myoides muscles were very rigid, and frequently contracted violently, causing acute pain. The patient was unable to bring his jaws nearer to each other than one-half an inch, while it was impossible for him to turn the head on either side, without at the same time turning the whole body.

The entire head was exceedingly sensitive to slight pressure with the fingers. The first application was made with an exceedingly mild and fine faradic current, and was of ten minutes' duration. With the hand and fingers as electrodes, we carefully manipulated the head, neck, and individual muscles, until the patient could close his mouth and turn his head to either side with some freedom, and without suffering pain or inconvenience.

In about a week the patient again presented himself. He could still close his jaws firmly, but was unable to turn his head as readily as before. A second application relieved him as completely as the first. To our regret we saw no more of this case after the second visit, but learned subsequently, however, that he retained the improvement, and, under internal medication, recovered.

*Intercostal rheumatism of long standing—Improvement under general faradization.*

CASE LXXVI.—A gentleman, sent to us by Prof. Austin Flint, was approximately cured of chronic rheumatism that chiefly affected the intercostal muscles.

For nearly three years he had suffered, from time to time, attacks of more or less severity, although at no time since the disease first manifested itself had he been entirely free from it.

It was a singular feature of his disorder that it was aggravated by the warm weather

of spring and summer. He was treated by general electrization with the faradic current every other day for six weeks. He gradually improved, and, when treatment was discontinued, he remained comparatively free from any symptoms of his late disorder.

*Subacute articular rheumatism—Muscular soreness and enlargement of joints relieved by three general faradisations.*

CASE LXXVII.—By the courtesy of Prof. Austin Flint we treated, in October, 1867, a case of subacute articular rheumatism in one of the wards of Bellevue Hospital. For three months the patient had suffered from muscular soreness of the back and shoulders, and a considerable enlargement of the right wrist and ankle and the joints of the first toes of the feet. Three general applications, with special reference to the diseased parts, dissipated the muscular soreness, and so decidedly relieved the lameness and reduced the enlargements of the joints that the patient was discharged from hospital in three weeks.

Both acute and subacute rheumatism occasionally occur complicated with neuralgia and nervous exhaustion, and are usually very persistent.

*Subacute rheumatism—Right deltoid muscle and several joints and fingers and left knee affected—Debility—Recovery under general faradization.*

CASE LXXVIII.—A gentleman, aged about 40, observed and treated by invitation of Dr. Howard Pinkney, in Oct., 1867, was suffering acutely from rheumatic paralysis of the right deltoid muscle, symptoms of inflammation of the sheath of the right ulnar nerve, swelling of several of the joints of the fingers of the left hand, and a very painful enlargement of the left knee, and great debility. It is proper to state that the patient, as well as his physician, ascribed his great nervous prostration partly to recent and excessive dissipation. The first application of the faradic current not only greatly reduced the temperature of the affected limbs, but restored in some degree the lost power of motion to the right arm. Under the influence of the current, the leg increased in size and remained in this condition for about a week, when the swelling rapidly subsided. The heat in the inflamed joints did not again rise to the same temperature, and the paralysis of the arm progressed gradually towards recovery from the first application.

Anesthesia of the deltoid was a marked symptom; but, as is usually the case, it was readily dissipated.

Treatment by electrization, together with potass. bromid., was continued from Oct. 21st to Nov. 9th, when the patient was discharged as approximately cured.

*Subacute articular rheumatism of nine months' standing—Approximate recovery under general faradisation and galvanization of the spine, sympathetic, and solar plexus.*

CASE LXXIX.—Mr. S., aged 40, had for nine months suffered constantly from subacute articular rheumatism. The paroxysms varied in severity, and the seat of pain and swelling was constantly changing from the finger-joints to the wrist and elbows, to the shoulders, hips, knees, and ankles. The most constant location of the disease was in the ankles and wrists, and in consequence incapacitated him from pursuing his avocation of a book-keeper. He was treated first by general faradization March 17th, 1873, and in a couple of days the galvanic current from ten ordinary zinc carbon cells

was directed along the spine from the sixth cervical vertebra to the solar plexus. This method of treatment, which was continued for two months, gradually lessened the tendency to swelling and irritation of the joints, and enabled the patient to resume his business.

When the treatment was discontinued, he had not entirely recovered, but during the summer he improved still further and through the following winter and spring was so little annoyed by his old enemy as at no time to be compelled to intermit his duties of writing, even for a day.

*Myalgia (Muscular Rheumatism).*—This name is commonly applied to neuralgic or rheumatic pain of the muscles on movement, caused usually by exposure to cold or dampness. It may be distinguished from ordinary neuralgia—*first*, by the fact that the pain occurs chiefly on movement and not on rest; and, *secondly*, by the fact that the soreness is diffused through or over the muscles, and not seated or fixed in certain nerve tracts. It receives different names according to its locality. In the back it is called *lumbago*; in the thoracic muscles, *pleurodynia*; in the neck it simulates torticollis or wry-neck so closely as oftentimes to be confounded with that affection (see Torticollis).

*Treatment.*—Local faradization with a mild current, either stable or labile, usually relieves such cases in a short time. Stable galvanization also with a mild current may be at once effective. Severe applications may increase the pain in this affection. The fact that the patient is not at once relieved, or is worse after the first application, should not discourage us, since the final result may be satisfactory. Of the large number of cases that we have treated, nearly all have been relieved by one, two, or more applications. A single application, with a *mild* current, prolonged for one or more hours, may sometimes entirely dissipate an attack of myalgia.

It is in myalgia that the belts, chains, bands, disks, etc., worn on the body, have obtained the best results. A convenient arrangement for making prolonged or continuous local applications of very mild galvanic currents is the electric disk of Dr. Garratt.



FIG. 102.  
Circle Disk.

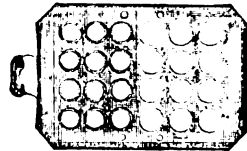

FIG. 103.  
Oblong Button Disk.

These are made of alloy—magnesium and zinc—for the negative, and silver for the positive pole. The surface of the body forms a moist con-

nection between the pairs, which are insulated by thin rubber. The disk is made in two general varieties—the circular and the oblong,—the latter being used for the limbs or back; the former, which is very flexible, can be applied to almost any portion of the body.\* The very slight galvanic action of these disks, which is excited by the moisture of the body, may be increased by wetting the skin beneath them with salt water. They should only be worn a part of the time, either in the day or night. They may be used for weeks and months.

That these and other similar contrivances, when scientifically constructed, may relieve slight *local and superficial* pains, there is no question. In the treatment of deep-lying affections of the brain, spinal cord, and viscera, or severe neuralgia, very many important results have not yet been reported for them. The results that appear under their use may, perhaps, be sometimes explained in part by their effect on the imagination of the patient, and by the counter-irritation which they unquestionably excite when long worn. To differentiate these effects is quite difficult.

*Complete relief of muscular rheumatism of several years' standing by a dozen applications of general faradization.*

CASE LXXX.—Mr. F., aged 30, was directed to us by Dr. Thompson. The patient was of a delicate constitution, and from childhood had been extremely susceptible to all external influences. A few years previous to his visit to us, he began to be severely affected by muscular rheumatic pains having their seat more especially in both shoulders and the chest.

He became anæmic and suffered much from cardiac palpitations. He was at once submitted to, and treated only by general faradization in its most thorough form. The effects were immediate and decided. He suffered less from the first séance, and in three weeks after the administration of a dozen applications, the relief the patient experienced was complete.

*Muscular rheumatism of the hips and limbs existing a month—Rapid recovery under faradization of the affected parts.*

CASE LXXXI.—Mr. S., an old gentleman of 65, was referred to us by Dr. J. O'Farrington.

The patient was suffering acutely from pain and lameness across the lower portion of the back and hips, while both thighs were so exquisitely sensitive as to render him utterly unable to walk. These symptoms had resulted from exposure to cold a month previously, and had resisted various methods of treatment. Faradization of the affected parts one evening just before retiring did not immediately allay the pain and tenderness; but the following morning found him able to take a few steps with comparative comfort, and by evening he had very perceptibly improved. The same application, repeated on successive evenings, enabled the patient in the course of a week to walk with considerable ease, and in a fortnight all lameness had disappeared.

\* For sensitive patients, and especially for ladies, the oblong "button-disk" is usually to be preferred, on account of its greater lightness and flexibility.

*Gout.*—In the chronic form of gout faradization is sometimes of essential service. General faradization and central galvanization may be tried with the hope of raising the tone of the system, and so as to enable it to better cope with the disease. Temporary relief of the pain may be derived from either local galvanization or faradization; but anything like a permanent removal of the disease is not to be expected from any form of electrical treatment.

With some gouty patients the electrical treatment acts so decidedly that we are disposed to resort to it during the subsidence of each attack, to relieve the pains and hasten recovery. Galvanization of the affected joints does not seem to produce the absorbing or catalytic effect that could be desired, although when judiciously used it accomplishes something. Whether any benefit can be derived from any form of electrization during the acute stages, we are unable to say.

*Gout of thirty years' standing in a gentleman sixty years of age—Positive relief from general faradisation in the subsiding stage of an attack.*

CASE LXXXII.—Mr. W—, a retired gentleman of 60 years, who had lived in considerable ease for a number of years, consulted us March 20, 1868. For thirty years he had suffered from attacks of gout, especially during the fall and winter seasons. When he first consulted us, he was in the subsiding stage of a severe attack. We gave him four applications of general faradization that relieved his pains and seemed to hasten his return to his usual condition of health during the intervals. Subsequently the patient resorted to electrical treatment, with decided benefit. Whether the treatment had the effect to diminish the violence or frequency of the attacks, we have not been informed.

*Rheumatic Gout (Arthritis nodosa).*—This affection is neither gout nor rheumatism, but appears to be a distinct constitutional affection. It occurs most frequently in the delicate and the nervous, and may be regarded as essentially a condition of debility. It is very apt to affect the hands, fingers, and toes, and sometimes thoroughly cripples the patient.

*Treatment.*—This condition is most successfully combated by tonics, and electrization, more for its tonic effects on the system than for any special catalytic power over the enlarged joints. General faradization, central galvanization, and galvanization of the sympathetic are the methods that experience has shown to be most useful in this very intractable malady.

*Prognosis.*—The prognosis in rheumatic gout is not brilliant. The pains can be relieved, the sleep can be improved, and the system can be in every way strengthened by the electric treatment, and even the enlarged joints can be made to diminish in size, or at least to be less



troublesome. As nearly all patients afflicted with rheumatic gout are in a condition of debility, the improvement experienced at first under general faradization is such as to lead them to hope for a permanent eradication of the disease. In this respect they are always disappointed. The disease may be held at bay, but is never banished. It is doubtful, indeed, whether the benefit is not entirely due to the tonic effects of the treatment on the system, and not at all to any special influence over the rheumatic gout.

Other remedies are so powerless in this affection that electrization is worthy of a trial for the sake of its general effects. We have treated a number of cases by general faradization, central galvanization, and local galvanization of the affected joints, with palliative and tonic effects of a most decided character. Dr. Althaus has had similar experience.

## CHAPTER XXIV.

### SPASMODIC DISEASES.

OF spasmodic diseases this general law holds, that when recent, even though violent, they yield readily to electrical treatment; but when long standing, they are easily palliated, cured with difficulty, and are prone to relapse.

*Writer's Cramp.*—This affection is not peculiar to writers. An analogous condition may attack seamstresses, milk-maids, and others whose callings compel them to use for a long time a certain set of the muscles of the hand. It is believed that the affection is not purely peripheral, but that it frequently, if not always, is connected with disease of the upper portion of the spinal cord.

Whether found in the artist, rendering him unable to manipulate his brush—the pianist, preventing him from fingering his instrument—or the penman, causing his writing to be almost if not quite illegible—the same general characteristic is observed, viz., the recurrence of spasm or pain whenever an attempt is made to execute a special movement.

Pains resembling neuralgia or rheumatism so closely as to be confounded with those diseases, frequently accompany writer's cramp.

The *prognosis* in the early stages is sometimes favorable for a perfect cure; advanced stages of long-standing cases are usually rebellious; but even these may be much relieved. *Rest from the occupation is almost imperative.*

The *treatment* should be both central and peripheral. Galvanization of the upper portion of the cord and of the median and radial nerves, spinal cord, plexus, and nerve-currents, and faradization of the affected muscles and of their antagonists, may be tried, and when anesthesia exists the wire brush.

Unfortunately, however, those who are most frequently subject to writer's cramp are the very ones who are unable to take the necessary rest.

Although the results of treatment by electrization in this variety of palsy is by no means uniform, yet it has undoubtedly been followed in many instances by approximate and even perfect recovery.

*Writer's cramp, existing for four years—Improvement under faradisation and galvanization.*

CASE LXXXIII.—For four years the patient, a gentleman aged 35, had observed a certain loss of power in the thumb and index finger of the right hand, that became more decided and annoyed him more and more seriously, so that about a year previous to his visit to us he was enabled only with difficulty to write the few pages daily that his business required.

The patient was unable to fully extend the thumb and index-finger, and on localizing the faradic current through the flexor longus pollicis and the adductor pollicis, there was a marked decrease in the electro-muscular contractility. The flexors and extensors of the other fingers responded normally to the influence of the current. The inner surface of the hand was decidedly anæsthetic, while he complained of a constant soreness of the wrist that at times became quite painful.

We began with the faradic current, localizing it through the two muscles of the thumb specially affected, and also making the application more general through arm, wrist, and hand.

This method completely dissipated the annoying anæsthesia and soreness of the wrist, but resulted in no other benefit.

A mild galvanic current from six Bunsen's cells was more effectual. Twelve applications resulted in a considerable increase of strength in the affected hand, and the flexor muscles of the thumb and index-finger very decidedly relaxed, so that he was readily enabled to accomplish two or three times more in the way of writing than before.

In some cases of writer's cramp, and especially in the early stages, *anæsthesia* or numbness is the leading, if not the only, symptom. This may appear long before the cramp.

*Incipient writer's cramp in an editor—Profound local anæsthesia—Rapid relief under localized faradization and galvanization.*

CASE LXXXIV.—Mr. H. C. B., a gentleman over 60 years of age, a prominent editor, was referred to us, November 20, 1872, by Dr. C. L. Mitchell.

The only symptom of which the patient complained was a numbness of the last two phalanges of the right index-finger. The electro-sensibility was so much diminished that a strong faradic current, which on the third phalanx and all the other fingers of the hand was intolerable, was but little felt on the last phalanx, and caused, indeed, rather an agreeable sensation. The æsthesiometer also indicated great anæsthesia. The muscles all responded well to the will and to electricity. The symptoms had existed about two weeks, and had come on gradually. There was no evidence of cerebral difficulty or of spinal sclerosis; in all other features, except the numbness, and a slight feeling of weakness, or rather of nervousness in the arm, the patient is well.

At that stage there was no tingling or pricking sensation, no neuralgia, and no spasms.

We made the diagnosis of incipient writer's cramp, partially by exclusion, and partially by the positive symptoms of numbness and weakness in the parts concerned in writing.

Faradization with sponges and the metallic brush gave immediate relief; the first sitting did much toward restoring the sensation. In nine days five applications; only the last phalanx of the index-finger remained anæsthetic. This part was obstinate throughout, especially on the very tip of the finger.

The patient now felt that he was well, and closed his visits, still working as usual with his pen as hard as ever almost all day long.

December 7th he returned, with a return of the symptoms of numbness, complicated with pricking and tingling sensations, neuralgia of the arm, and great debility. Long writing caused great uneasiness.

Absolute rest from writing was now demanded, and the patient obeyed, still using his brain, but employing a secretary. Again he began to improve under peripheral faradization and galvanization, and galvanization of the upper part of the spine and cervical sympathetic.

January 1, 1873, he was very much better—indeed, nearly well. That day he slipped, and fell down the steps of his house, and struck on the hand and shoulder of the affected arm. The shock lamed him greatly, and caused for a long time stiffness and much pain of the shoulder.

The electrical treatment was renewed, January 14th, and continued every other day during the month, with satisfactory results. The enforced rest—for the patient was confined to the house—co-operated with the electrical treatment.

*Torticollis (Wry-neck).*—This familiar disease consists in a spasm of the muscles of the neck, by which the head is drawn to one side. The spasms may be tonic or clonic.

Although the pathology of the disease is obscure, it is yet quite clear that it is of a nervous character. More than by any other cause, it is brought on by excessive mental labor or anxiety. The symptoms usually come on gradually; the muscles of the neck on the side toward which the neck is turned are sometimes flabby and atrophied, and the muscles on the other side are hard, lumpy, and enlarged. Frequently the deeper muscles of the neck are involved, as well as the sternocleido-mastoid and trapezius. The spinal accessory nerve would appear to be at fault. The condition is really a kind of "partial chorea," analogous to writer's cramp, facial spasms, spasm of the eyelid, and, like all these, is usually very obstinate, except in the mild form and early stages. *The disease is frequently brought on by excitement or worry.*

*Diagnosis.*—The disease should not be confounded with common stiff-neck that is caused by rheumatism of the muscles of the neck and is analogous to lumbago. In stiff-neck, which usually yields to faradization like other forms of myalgia, the head is kept from moving by the pain which movement causes. Diseases of spine and diseases of the brain sometimes produce tonic spasms of the muscles of the neck that resemble torticollis.

*Electric Examination.*—On the affected side \* the muscles sometimes exhibit increased electro-muscular contractility and sensibility. On the other side the electro-muscular contractility is sometimes diminished.

*Treatment.*—Galvanization of the muscles of the affected side with mild currents, and faradization of the muscles of the other side, galvanization of the sympathetic and cervical spine, are the methods that should be tried in this disease. They may be tried simultaneously or in succession.

Protracted applications are not ordinarily indicated in this affection. General treatment is only required when the patient is debilitated.

In connection with the use of electricity, the hypodermic injection of morphine and counter-irritation of the cervical spine by blisters, and mechanical contrivances for keeping the head in position, may be tried.

*Prognosis.*—In the early stages torticollis may be relieved or cured by electrical treatment alone. After it has been established for a number of months, it becomes one of the most intractable of diseases. Even when relieved by treatment, it is much disposed to relapse. No case should be abandoned until both galvanic and faradic treatment has been thoroughly tried, since it is the only method of treatment that offers even any hope; and the physician should not be discouraged if the symptoms appear to be aggravated by the first few applications, but should reduce the strength of the current and the length of the sances. The same remark will apply to analogous diseases, such as writer's cramp and facial spasm.

*Torticollis of long standing, brought on by over-confinement and anxiety—Some relief from faradization and galvanization.*

CASE LXXXV.—Mr. K—, aged 40, was sent to us June, 1870, by Dr. Willard Parker. For several years before the attack appeared he had been in his usual health, but had been severely confined and much distressed by the cares of business. The symptoms appeared gradually; they were at first slight, and only developed their full force after several weeks. When we first saw him he had been suffering for several months. His face was almost constantly turned toward the left side. On the opposite side the sterno-cleido muscle was considerably hypertrophied, and on the other flabby. The position of his face and the violence of the cramp were much dependent on mental influences, being aggravated by exhaustion or worry.

*Electric examination* showed increase of electro-muscular contractility in the af-

\* It should be considered that the sterno-cleido-mastoid, as it pulls the back of the head toward the shoulder, turns the face in an opposite direction. The face therefore is turned away from the affected muscle.

fect side, and diminution on the opposite side (towards which the face was turned). Careful examination revealed no evidence of disease of the vertebræ.

The patient was treated by stable galvanization of the hypertrophied and hardened muscle, by spinal-cord brachial plexus current, by galvanization of the sympathetic and spine, by faradization of the flabby muscles of the opposite side, and by general faradization. In three weeks there was positive but not marked improvement; there was decrease of the hypertrophy of the muscle and some diminution of the spasm.

*Torticollis of a month's duration—Rapid recovery under local faradization.*

CASE LXXXVI.—Miss B—, aged 20, was directed to us by Dr. W. W. Jones, of New York. A month previous, she caught cold in the neck from a draught of air while at a concert. For a week subsequently, she would, every few moments, involuntarily turn her head to the right, until finally it became fixed in this position. From the fact that she was not prevented from turning her head, simply from pain, and that when it was brought to the proper position by faradizing the muscles, no pain was caused, we concluded that we had *not* to deal with a common stiff neck resulting from rheumatism, but with tonic spasm of a nervous character. The muscles of the neck on the side towards which the head was turned, had appreciably atrophied, while on the opposite side they were hard and enlarged. These latter muscles exhibited, as usual, increased electro-muscular contractility, while on the right side, towards which the head was turned, contractility was diminished. The above phenomena represent fairly, we think, what are usually observed in the earlier stages of the disease, and the following treatment is typical of what we have successfully employed in a number of similar cases. At each sitting, the muscles of the left side (those that were large and prominent) were submitted to mild galvanization for a moment or so, while the contracted sterno-cleido-mastoid muscle of the right side, towards which the head was inclined, was faradized with sufficient force to cause a relaxation of muscular fibre, allowing the head to turn gradually to its natural position. Upon removing the electrodes after the current had passed several minutes, the head would retain its position without the conscious aid of the patient's will. After an interval of some five minutes, it would again turn to the right. The patient rapidly improved, and after two months of treatment had quite recovered.

*Paralysis Agitans (Shaking Palsy).*—There are two kinds of shaking palsy:—

1st. *Those with organic lesions.*

Sclerosis of some form is the pathological state that usually gives rise to the symptoms of shaking palsy.

2d. *Those where no lesion can be discovered.*

These are usually styled functional, although, like hysteria, they may be supposed to depend on some molecular derangements which are not revealed to the microscope.

The disease may be local or general; it may attack one limb, or the

lower jaw, or all four extremities. It is most frequent in the aged, but is sometimes observed in middle life, or in the young.

*Treatment.*—Central galvanization and general faradization, for general effects, may be used in shaking palsy with benefit. The best results have been obtained by galvanization of the spine and sympathetic and brain.

*Prognosis.*—Cases where all the limbs are affected are never cured by any method of treatment, especially in the aged. Cases in which only one limb, or one upper and one lower limb, are affected are sometimes benefited, and in rare instances cured. Temporary relief can sometimes be obtained where no permanent benefit results. The tremor of the limb is sometimes abated or completely arrested for one or more hours after the application *either of general faradization or galvanization of the spine*, and in rare cases entire recovery occurs. Dr. Russell Reynolds has reported a cure by the galvanic current. Recently Jules Chéron, of Paris, has published the results of galvanization in 7 cases. Of these 2 were cured; 2 were much improved; and 3 were much improved in their general condition, but not in the tremor.

*A case of palsy agitans associated with spasmodic muscular contraction and neuralgic pains—Approximate relief from central galvanization and general faradization.*

CASE LXXXVII.—MRS. M., aged 50, applied to us for the relief of a disorder of which the following were the main symptoms. These symptoms had been almost constant for more than fifteen months:—

The patient was so exceedingly feeble, that a walk of a few blocks caused complete exhaustion.

Neuralgic pains in the face, right arm, and side, were constant although varying in intensity. Sometimes the distress was for hours most excruciating, and then an interval of rest would occur in which the pain was barely appreciable. Pain along the spine, but no tenderness to pressure. The most annoying symptoms were frequent spasmodic contractions of the muscles of the neck, while a constant and incessant trembling of the hands during the waking hours made with the rest a complication of symptoms that pointed to structural change of the upper portion of the cord. Central galvanization was in this case alternated with general faradization. So far as the spasmodic contractions of the muscles were concerned, the effect was immediate, being followed by complete and permanent relief.

The neuralgia was gradually dispelled, and the trembling or shaking in the course of two months' treatment so benefited as to be hardly noticeable. During the summer that followed, the patient was almost entirely free from every unpleasant symptom.

*Unilateral paralysis agitans in a man aged sixty years—Very decided alleviation of symptoms under central galvanization.*

CASE LXXXVIII.—MR. JAMES A., aged sixty years. Suffering from unilateral

palsy agitans of the left side. Was placed under our care by Dr. Andrews, of Utica, August 1, 1870.

The first symptoms of this disease became manifest in October, 1869, and gradually increased in severity until January, 1870, since which time there had been no appreciable aggravation of his condition. The patient was a mechanic, occupied almost constantly in filing saws, and it was his firm impression that the peculiar influence transmitted to the cord by the steady scrape of the file was an important factor in the production of the disease. However this may be, it was certain that he was now unable to use his file a moment without causing most disagreeable feelings.

We essayed a few applications of general faradization, but as it did not seem to allay any of the disagreeable features of the disease, we resorted to central galvanization. After a few applications to the brain, sympathetic, and spinal cord, the speech, which was decidedly affected, so that he stuttered and hesitated in every effort to talk, became perfectly normal, and he was no longer annoyed by it. For many months he had been unable to sleep, unless lying on the back with the arms pressed to the side. In four weeks he was able to sleep with perfect comfort in any position.

The patient remained under observation some three months, and received in all about twenty-five applications. He improved in his general condition very decidedly, the arm and leg became much stronger, and the shaking movements decreased in severity at least fifty per cent. Further than this we were powerless to assist him.

*Asthma.*—Asthma is one of the conditions for which it would be supposed, *à priori*, that electrization might be of service; and yet the published records of successful treatment are not very extensive. One of the earliest, if not the very earliest, experimenters in this department was Dr. Wilson Philip, who began his researches in electricity in the early part of this century. "By transmitting its influence (galvanism) from the nape of the neck to the pit of the stomach, he gave decided relief in every one of twenty-two cases, of which four were in private practice, and eighteen in the Worcester Infirmary. The power employed varied from ten to twenty-five pairs." The treatment which is theoretically indicated is galvanization of the pneumogastric and sympathetic. Benedikt mentions a case successfully treated by this method.

The methods we employ in asthma are galvanization of the pneumogastric and cerebral galvanization, and usually with temporary, though not, as a rule, with permanent benefit.

The faradic current is sometimes effective in affording temporary relief after failure of the constant current. In several cases that have fallen under our observation persistent faradization of the chest and neck has been followed by marked relief.

*Asthma of three months' standing—Apparent recovery under localized galvanization.*

CASE LXXXIX.—Ann M. C., treated at Demilt Dispensary, had her first attack of asthma three months before seeking electrical treatment. Every few days thereafter



a paroxysm of considerable severity would prostrate her. Before the onset of the attack she invariably experienced a cold sensation between the shoulders. The expectoration, which so soon as she can throw off affords relief, had the appearance of boiled starch. The smell of cooking always hastened an attack. The patient was treated from May 18, 1871, until June 17th, by the method of localized galvanization, when she was discharged apparently cured.

*Asthma of many years' standing—Decided temporary relief from local faradization—No permanent benefit.*

CASE XC. — June 20, 1871, we treated an old gentleman, a patient of Dr. John T. Metcalfe, for a chronic asthmatic difficulty of many years' standing. He was submitted mostly to galvanization of the great sympathetic, pneumogastric, and phrenic nerves, but the only decided relief obtained was from simple faradization, the positive pole being placed at the back of the neck, and the negative just above the sternum. This method caused a most pleasant relief from discomfort on awakening at night. No permanent benefit, however, was afforded by the treatment.

*Muscular Contractions.*—These may arise in hysteria, in myelitis, meningitis, and spondylitis, diseases of the cerebrum and cerebellum, or they may be of a reflex character. They exist sometimes in neuritis or rheumatism.

The *treatment* consists in peripheral galvanization or faradization of the affected muscles or of their antagonists, with stable currents and galvanization of the head, spine, and sympathetic, according to the special indications.

The *prognosis* is usually unfavorable for all except the rheumatic cases.

*Facial Spasm.*—This affection, which is not unfrequent, is usually very obstinate against all treatment. The treatment is galvanization with the spinal-cord-muscle or nerve-muscle current. Recent cases may be cured by the application of the galvanic current to the branches of the fifth pair. Long-standing cases may be temporarily relieved, but are rarely permanently cured. Remak reported success even after the condition was very chronic.

*Dysphagia from Spasms of the Pharynx.*—This symptom, though sometimes the result of organic central disease, is not unfrequently of a purely spasmodic character, and as such is amenable to electric treatment, either by external or internal applications. The method we adopt for such cases is to place one pole on the back of the neck and the other just above the sternum, or by the inner border of the sterno-cleido-mastoid muscle. If this method fails, internal applications may be made, by means of a catheter-shaped electrode, against the constrictors of the pharynx. Some cases yield with surprising readiness to ex-

ternal treatment. Cases dependent on central disease are usually quite rebellious.

A case of this kind, in which the food was returned through the mouth or nose, was cured by Hiffelsheim by galvanization.

Heffelsheim has recorded a case of excessive and obstinate vomiting that was cured by five applications of the galvanic current to the pneumogastric.

*Dysphagia from spasmodic action—Recovery from localized faradization, twice repeated.*

CASE XCI.—An old lady, aged nearly 70, was sent to us by Dr. Fordyce Barker. She had for some months been annoyed by much difficulty in the act of swallowing, and was apprehensive of suffocation on account of the tendency of food to lodge in the œsophagus. Localized faradization, repeated twice, completely relieved the spasmodic tendency, and enabled the patient to eat without fear of consequences. So far as we are aware the relief was permanent.

*Singultus (Hiccough).*—This symptom, when it becomes permanently annoying, may be treated by *galvanization of the sympathetic and pneumogastric*. We have treated in this way two very obstinate cases with out benefit.

*Tetanus.*—Dr. Mendel has reported two cases of tetanus successfully treated by the galvanic current. He used various methods of application, central and peripheral. Immediate relief followed each application.

The conclusions at which he arrives from his cases are that a mild current should be applied to the affected muscles, without regard to the direction of the current, although the positive pole should be applied to the antagonists.

*Hydrophobia.*—The disease is so rare in its occurrence, and so rapid in its course, that electrical treatment even by its most imperfect methods, has had almost no chance to be tested. The suggestions that we have to offer are therefore of necessity based on theory and analogy, and experience in the treatment of other and more or less allied diseases.

The best method of using electricity in a case of real or simulated hydrophobia would be to place the negative pole of the galvanic current at the pit of the stomach, and apply the positive successively at the top of the head, the nape of the neck (*central galvanization*), over the region of the pneumogastric, and down the spine. If the galvanic current cannot be obtained, the faradic (electro-magnetic) might be tried, although it would probably be less efficacious. Mild or moderate currents would be likely to do more good than very powerful currents, and

there should be intermissions in the treatment. During these intermissions ice-bags might be applied to the spine. We should not expect that this treatment would cure real hydrophobia, but, if faithfully used, it would greatly relieve the horrible agonies of the disease, and, either alone or in connection with other treatment, would be likely to prolong life. Electricity has never yet had a fair trial in hydrophobia. Schiavardi, who kept one of his patients alive several days, used only a partial and imperfect method, and no other treatment, so far as is known, has been so successful.

Hydrophobia is one of the very few diseases in which it is better to use electricity blindly and imperfectly than not to use it at all. There are two considerations, however, that are somewhat discouraging :

1. The spasmodic affections that most closely resemble hydrophobia and with which it is sometimes confounded—epilepsy, tetanus, etc.—do not yield readily and permanently to electrical treatment. Great benefit can be derived from a proper use of electricity in epilepsy, but very rarely a permanent cure.

2. To get the best results of electrical treatment time is necessary. Save in the resuscitation of the drowned or asphyxiated, and the temporary relief of pain, electricity accomplishes its great cures slowly. Hydrophobia runs its course rapidly, and, in its incipience, is not usually recognized. The only hope that real hydrophobia could be cured by electricity rests in the possibility that it could relieve the symptoms and delay death through its powerful sedative influence, so that there would be more time to act upon the nutrition of the nerve-centres either by a continuance of the electrical treatment or by other methods. There is reason for the belief that some at least of the cases of so-called hydrophobia are of an hysterical character—are brought on by fright and dread. The only safe course is to treat such cases as though they were genuine cases of hydrophobia. The most brilliant results of electrical treatment are obtained in hysteria and allied diseases, and notably in hysterical convulsions, and it is quite probable that the hysterical symptoms of hydrophobia would yield to the same remedy. The result of the treatment would help somewhat the diagnosis. If the patient entirely recovered, the probability that the case was of an hysterical nature would be strengthened almost into certainty. Inasmuch as one or two of the recent cases were probably in part hysterical, and as the discussion of the subject has caused our sensitive and highly nervous people to dwell on this dreadful topic day and night, it is not impossible that other cases of a like nature may occur.

*Stammering.*—Dr. Althaus succeeded in curing a case of stammering

of five years' standing, in a lad nine years of age, by the application of the galvanic current to the laryngeal nerves. The applications were made twice a week for two months.

*Epilepsy.*—Epilepsy is one of the diseases for which electricity in some form or other has been used for many years, though with rather uncertain and capricious results. The method of treatment that promises most in this disease is central galvanization. Another method is to place one of the poles over the point whence the aura proceeds, and the other over the nerve-centre.

Temporary relief can be obtained in very many cases of epilepsy by electrical treatment. The intervals between the attacks can be greatly lengthened, and in a certain proportion of the cases the results are believed to be permanent.

*Petit mal.*—*Marked temporary relief from general faradization and galvanization of sympathetic—Relapse.*

CASE XCII.—In one case of "petit mal," occurring in a boy some 13 years of age, the bromide, given in doses of 10 grs. three times a day, acted charmingly. The paroxysms, which for nearly two years had occurred from six to ten times a day, were immediately reduced to one, two, and three in the twenty-four hours.

This improvement was manifest for nearly a month, when, notwithstanding the increased doses of bromide, the paroxysms gradually increased in frequency, until the patient was rendered unconscious by them as often as before. We now resorted to general electrization with the faradic current, and occasionally to galvanization of the sympathetic. Singularly enough, the results that followed were substantially the same as those obtained from the administration of the bromide of potassium. For a few weeks the frequency of the epileptic seizures was reduced to one and two a day, when, notwithstanding every effort, there was a second relapse to his old condition.

The boy evidently inherited a very decided nervous diathesis, but the exciting cause of the attacks was ascribed to a severe fall some weeks before the manifestation of the first paroxysm.

*Epilepsy of eleven years' standing—Periodical attacks—Improvement in sleep and mental condition, and diminution of attacks under general faradization—Nothing further gained by galvanization.*

CASE XCIII.—W. H. V., a lad aged 16, began first to suffer from epileptic seizures when but five years old.

For the first five years the attacks, consisting of a number of fits in rapid succession, occurred every five or six weeks. From his eighth to his fifteenth year the paroxysms increased in frequency and severity, until, at the date of his visit to us, the attacks recurred every week.

It was a noticeable fact that for the last year the patient had almost invariably suffered from these epileptic seizures on Saturday.

The boy had grown sensibly weaker both in mind and body, and was excessively irritable and capricious.

Treatment was commenced by general faradization, with special reference to the head and spine.

Under this treatment sleep became more sound and refreshing, and the mind calmer, while the usual paroxysm was delayed until the Thursday following the regular time for its recurrence. The general condition of the patient continued to improve, and a second attack was delayed four weeks. He remained under observation some months longer, having a paroxysm (far less severe, however, than formerly) about every four weeks. The galvanic current, variously used, seemed to accomplish nothing that had not already been obtained by the faradic. The case soon after passed from our care, and whether relapses have occurred we have not been able to ascertain.

*Epilepsy of five years' standing—Apparent recovery.*

CASE XCIV.—Miss W., aged 30, came to us November 4, 1876, with the following history: In the early part of 1872 she had her first attack in the night, while asleep, but for a year previous had occasions of being in a dazed condition with great confusion of memory.

It is as well to state that there had been all along in her case a strong hysterical element that is frequently aggravated by surrounding influences.

The attacks for awhile occurred once in about seven weeks, and further on, instead of a single paroxysm, she would have two and sometimes three in the succeeding twenty-four hours. Later still, the attacks became as frequent as once a month, with one or two longer intervals. We learned that Dr. Geo. J. Fisher, of Sing Sing, had formerly been her physician, and, in answer to a letter of inquiry, he informed us that the patient had been under his care for a long time.

He had given her the bromides of potassium and soda (of each 10 grs.) three times a day. This she had taken for several years, and was still taking when she came under our care. During the month previous she had three attacks, and was feeling certain premonitions, which she described, when we submitted her to the additional treatment of the electricity. We did not feel justified in discontinuing medicine, but in order to give her every chance, substituted for it the formula of Brown Séquard.

The patient was exceedingly nervous and despondent, and it was evident that if in no other way electricity might prove of service as an adjunct to allay irritability and as a general tonic.

We treated her every other day for three months, alternating central galvanization with general faradization. We then gave her an interval of rest for three months, during which time she had an attack, occurring a little more than six months from the last. After a second three months' treatment, we allowed another interval of rest, and again treated her for three months. She has not had a second attack, and as two years have passed, during which she has had but one seizure, we are hopeful of ultimate results. It is worthy of note that since the two methods of treatment have been combined the bromic acne has very considerably lessened and at times is hardly perceptible.

## CHAPTER XXV.

### DISEASES OF THE SKIN.

THERE are several theoretical considerations that would lead us to suppose that electricity might be of service in the treatment of diseases of the skin:—

1. Pain and itching, oftentimes of a very distressing character, accompany many of the diseases of the skin, and of all the known methods of relieving and curing pain, electricity is one of the most satisfactory. If the application of the galvanic or faradic current may bring relief in headache, in spinal irritation, in the various forms of neuralgia, in rheumatism and in sprains, why should it not afford similar relief in the tormenting agonies of psoriasis, eczema, and prurigo?

2. Ulcers, sinuses, and bed-sores have long been treated by the galvanic and faradic currents, with gratifying success; and it would be natural to suppose that the ulcerous conditions of some of the diseases of the skin might similarly be benefited.

3. Tumors and morbid growths of various kinds are discussed by the electric currents, and especially by the galvanic current, and it would be reasonable to infer that cutaneous indurations and hypertrophies might be discussed or diminished in a similar manner.

4. Those who hold the theory that some of the diseases of the skin are of a nervous origin, or are in some way intimately dependent on the brain, spinal cord, or sympathetic, would find still another theoretical argument in favor of introducing electricity into dermatology, since nervous diseases have long been regarded as *par excellence* the diseases most amenable to electrical treatment.

The electro-therapeutics of diseases of the skin belongs both to *medical* and *surgical* electricity. The tendency in recent times has been to transfer dermatology from surgery to medicine, and at present many of our most eminent dermatologists are physicians more than surgeons. This tendency is further strengthened by the modern views of the pathology of cutaneous disorders, particularly in regard to their relation to the nervous system. The purely local treatment of diseases of the skin by

electricity might be regarded as belonging to electro-surgery, while their general and central treatment certainly belongs to electro-medicine.

*Current Employed.*—While both currents—the faradic and galvanic—have proved useful in the treatment of diseases of the skin, the galvanic appears to act more efficiently and to fulfil a larger variety of indications than the faradic. The reason of this will be sufficiently clear to those who understand the general differential indications for the use of the two currents. The peculiar electrolytic action of the galvanic current, which the faradic current possesses to but a feeble degree, is indicated in diseases of the skin for the same reason that it is indicated in the discussion of tumors. For the relief of the symptoms of itching and pain, the faradic current is frequently sufficient, especially in prurigo: its effects are also curative, but to a less degree than the galvanic current. The galvanic current also acts more powerfully on the central nervous system (see Chapter IV.).

*Methods of Application.*—Diseases of the skin may be treated electrically in two ways—by applications to the diseased surface, and by central galvanization. In the first method the disease is affected directly; in the second method it is affected indirectly through the nervous system.

*Application to the Diseased Surface.*—Our usual method of galvanizing the affected part is to place an adjustable electrode of from two to four inches in diameter over the point where the principal nerve that supplies the part is most superficial,—as the popliteal space, the anterior crural region, the border of the flexors of the arm, etc., while the negative is applied to the diseased surface by any convenient electrode with a broad surface. This is the method that we usually adopt in the treatment of ulcers. We are not able to say how much advantage there may be in applying one of the electrodes over the nerve. We suspect that it may be of service in improving the nutrition of the part that it supplies; it certainly cannot do harm in that position unless the séance is very much protracted. One electrode may be placed on some indifferent point, as the feet, or the hands, or on the thigh, where currents are borne well and can do no harm, however long they may be kept there. The electrode is sometimes kept firmly planted on the skin (stable), and sometimes is slowly glided from one part to another (labile). When the part is much abraded only mild currents will be borne, while in the immediate neighborhood a very strong current may not be felt at all. It therefore becomes necessary to modify the current continually according to the sensations of the patient, so that the treatment may never be excessively painful. There is yet no evidence

that very severe applications have any advantage over mild applications. The pain of the galvanic current increases with the length of time that the electrode is kept in a fixed position without breaking the current; for this reason it is necessary, when strong currents are used, to shift the position of the electrode every minute or so, or as often as the patient complains of severe pain. We are not able to say whether the best results are obtained by stable or by labile applications. The electrolytic action of the galvanic current is most decided when there is little or no interruption to the current. When the faradic current is used we generally make labile applications.

Both electrodes may be applied on the diseased surface. The advantage of this method is that it economizes time and labor where there are numerous and large patches that need to be treated. Although the electrolytic action of the negative pole is greater than that of the positive, yet both act electrolytically, as all physicians know, and both act curatively as experience shows.

When the body is covered pretty generally by disease, we sometimes put an electrode on each limb, thus allowing the current to run through the body.

*Local Faradization Generalized.*—We have recently applied this term to a method of using electricity which combines the advantages of localized and general faradization. Although we first used it in diseases of the skin, it may be employed to meet the same indications as general faradization; but since it requires absolute or approximative stripping on the part of the patient, it would be called for only in a limited class of affections.

In this method the operator takes hold of both the electrodes, by their insulated handles, and passes them, within a few inches of each other, over all the diseased surface of the body. The electrodes may be kept stationary over spots where the disease is especially prominent. The method may be modified in various ways. One electrode may be kept fixed on some particularly bad spot, while the other is glided up and down the surface adjacent, or both electrodes may be kept fixed a part of the time. An advantage of this method, which may be employed with either current, is that it economizes time and labor, a very important consideration in cases where a large portion of the surface of the body is diseased.

This method is especially indicated in cases where nearly the entire surface of the body is affected by disease, as in general prurigo and psoriasis. Either current may be used in this way.

*General Faradization.*—This method of using electricity is usually



not indicated in diseases of the skin, and for the reasons already given. For those cases that are associated with general debility as a result or cause of the disease of the skin, it may be employed with advantage; one pole may be applied at the coccyx by an adjustable electrode, or at the feet by a copper or tin plate, while the other is passed over the surface of the body.

*Electric Brush.*—When the skin is not itching or anæsthetic the electric brush is very painful, and is therefore to be recommended chiefly for cases where there is very great irritation, or itching and anæsthesia. We have frequently found it more efficacious than the ordinary sponge electrode. In some conditions of eczema an application, which in health would be unendurable, is positively agreeable. The distinctively surgical methods of treating certain diseases of the skin by electrolysis and galvano-cautery will be described in Electro-Surgery.

*Central Galvanization.*—This important method of using electricity we have recently proved to be of great service in the treatment of certain diseases of the skin, especially of chronic eczema and prurigo. Under this method of treatment *alone, without making any application whatever to the diseased surface*, the itching and burning of these diseases are relieved sometimes immediately, and under a protracted treatment permanent cures are obtained. The results obtained by this method are of the highest possible interest in a pathological point of view, as showing a kind of dependence of chronic eczema on the nervous system that had not before been suspected.

*Diseases of the Skin for which Electrical Treatment is Indicated.*

—Under this head we sum up the results of electrical experience up to the date of publication.

*Eczema.*—This disease we place at the head of the list, for the reason that we have found more rapid, brilliant, and uniform results from electrical treatment in this than in any other disease of the skin. We have treated the chronic forms in different parts of the body, and in nearly all cases thus far with immediate relief of the distressing pain, and ultimate cure after a course of treatment. We have used for this affection, almost exclusively, the *galvanic* current, either locally or centrally. Patients have come into the Dispensary declaring that the distress is so great that they would be glad to have the suffering part amputated, and after an application of from five to fifteen minutes have gone out entirely relieved. This relief lasts for several hours, sometimes for days, and the pain grows less and less until the cure is accomplished.

It is in this disease especially that central galvanization alone, without making any application whatever to the diseased part, has accomplished such striking results.

The following case illustrates the power of central galvanization in a most striking manner :—

*Severe and obstinate chronic eczema of leg, eight years' standing—Intolerable itching—Failure of various remedies—Rapid relief and permanent cure under central galvanization.*

CASE XCV.—Mrs. S. M., an Irish servant-girl, aged 51, was admitted to the Long Island College Hospital, February 14, 1872, with chronic eczema of the left leg about the ankle, and extending one-third of the distance to the knee. The itching and pain were intolerable, and there was much soreness. The patient was in other respects strong and well, but had suffered from this affection by intervals for eight years. Four years before she had been under treatment at the City Hospital, and had been discharged apparently cured, but relapsed.

The case was treated by iodoform, arsenic, bicarbonate of soda, rhubarb, carbolate of zinc, glycerine, cod-liver oil, iodide of potassium, dulcamara, acetate of lead, wine of colchicum, and acetate of potash. These remedies were variously used in various modifications, externally and internally. From some of these agents the patient derived temporary relief of the itching and soreness; but the average and ultimate effect was, that on April 1st the following record of the case was made in the hospital book: "Very painful, red and angry, rapidly extending, and now covering nearly the whole leg below the knee, and most of the dorsal aspect of the foot."

Arsenic and tincture of cinchon. comp. were now ordered, but April 15th, the record was: "Very much the same." At this time, Dr. Davis suggested *localized faradization*. This suggestion was acted on with gratifying result; the intense distress was at once in a measure relieved.

April 16th, the patient was more comfortable than for a long time previous.

April 23d, very much improved and comparatively comfortable.

At this time Prof. A. B. Crosby, the surgeon in charge of the ward, requested us to see the patient, stating that she had been very obstinate under the various remedies that he had tried. The patient was suffering greatly from the severe itching and burning, and the soreness was so great that only with difficulty could she hobble about the ward. The appearance of the diseased part was red and angry, and some portions were more or less covered by scales.

We decided to try on the patient the effect of *central galvanization, making no application whatever to the diseased part*. We were induced to make this trial on the strength of successes in other and milder cases of cutaneous diseases. Our chief hope was, perhaps, to relieve the itching and pain; a permanent cure we had no reason to anticipate. As the patient was a good and willing subject on which to demonstrate electrical applications, she was taken before the class of the Long Island College Hospital, and treated by central galvanization, the statement being made, that we did not hope thereby to cure, but simply to illustrate the method of using electricity.

The details of the applications were entrusted entirely to Dr. Edwin E. Smith,

house-surgeon, who carried out the treatment with great faithfulness, and to whom we are indebted for the full history of the case as here presented.

The relief of the itching and pain was very rapid, although on the 25th Dr. Smith made the following record: "A little more irritable." This result was probably due to over-treatment, too strong currents, or too prolonged applications.

*April 30th.*—Patient "much better."

*May 10th.*—"Still steadily improving." The appearance of the leg was now much changed for the better. The most obstinate portion was the region about the ankle.

The applications were now made four and five times a week with a 12-cell zinc-carbon battery of Kidder for about ten minutes at a *séance*.

*May 25th.*—A lotion of acetate of lead wash was ordered by Dr. Crosby, to contract the enlarged capillaries.

*June 5th.*—"Patient is walking about out-doors with comparative ease, and is nearly well."

We again presented the case before the class of the College, demonstrated on her our method of central galvanization, and pointed out the extraordinary and unlooked-for improvement. The skin of the whole leg, except around the ankle, was well, and the patient for a long time had been entirely free from itching and pain.

*June 15th.*—The patient was "discharged cured."

*Jan. 13th, 1873.*—Dr. Smith informs us that there has been "no recurrence of the difficulty." Several months after the patient left the hospital we heard that she was still well.

The above case, taking all the facts into consideration, its long standing, its inveteracy under manifold treatment, and the immediate and rapid relief and cure under central galvanization, is certainly most extraordinary, and it will not subtract from the instructiveness and brilliancy of the result, if in future years a fresh attack of the disease should occur. Although the case was not, so far as we know, studied by any recognized specialist in dermatology, yet among the very many surgeons and physicians who watched its progress before and during the electrical treatment, there was, we believe, no difference of opinion in regard to the diagnosis, and there was no question that the cure was wrought entirely by *central galvanization, acting upon the central nervous system*, and thus improving the *peripheral* nutrition. This very remarkable experience, which to some has seemed incredible, we have recently confirmed in a similar case of chronic eczema of the legs of sixteen months' standing. The relief of the itching by central galvanization alone was immediate, and after a few application the disease began to improve in appearance, and in six weeks there was approximate recovery. At the date of writing the patient is entirely well. When the patient was about half cured he was seen by Dr. L. D. Bulkley. Dr. Kinsman, of Columbus, Ohio, writes to us that he has successfully treated, by central galvanization, a severe case of impetiginous eczema of twenty years' standing.

*Chronic eczema of the legs and feet, one year's standing—Relief of pain and itching under localized faradization and galvanization.*

CASE XCVI.—Michael P., aged 64, had suffered for twelve months from chronic eczema of the legs and feet, accompanied with terrible itching and burning sensations. The affected parts were but little sensitive to the electric current, either galvanic or faradic. Localized galvanization and faradization were employed, and some of the time the electric brush with a strong current was not only well borne, but was most grateful to the patient. The applications were made from five to twenty minutes. *In all cases there was relief of the distressing pain.* Symptoms of relief began to appear soon after the beginning of the *sance*, and at the close was sometimes absolute. This relief lasted at first from two to twelve hours.

The patient continued treatment for three weeks—in all six applications were made. The intervals of relief were sensibly lengthened, and the patient abandoned treatment. With the relief in the itching and pain there was corresponding relief in the appearance of the diseased parts. We have no reason to believe that the patient was permanently cured.

*Eczema of the scalp of three months' duration in a gentleman seventy-five years of age—Recovery in two months under local galvanization and general faradization.*

CASE XCVII.—Mr. L., aged 75, was affected with eczema of the scalp. The eruptions extended over the entire portion of the head covered by the hair, and had persisted, in spite of many external applications, for nearly three months. The diseased part was covered with thick scabs which tended to coalesce and cover as by one huge mass the entire surface. The scalp was quite irritable, and at night especially the patient was annoyed by an irresistible desire to scratch. The bowels were decidedly constipated, and the general health, although usually good, was at this time considerably below par. The patient submitted to treatment by both localized galvanization and general faradization. The first application of the former method resulted in a decided relief to the constant itching.

After two weeks' trial of both methods, some of the scabs began to dry up and peel off, constipation was very much relieved, and the general health had improved in marked degree.

This improvement slowly went on, until in two months from the beginning of treatment the scalp was quite free from disease.

*Prurigo.*—If electricity could do nothing more than relieve the itching of prurigo, it would be entitled to an honorable place in the armamentarium of the dermatologist. Dry faradization alone may bring relief in a very few minutes, and, when perseveringly used, may cure. We have seen immediate relief follow general faradization used in the ordinary method with wet sponges. In this disease also central galvanization alone has in our hands been very effective.

*General prurigo, six years' standing—Intense itching—Approximate cure after fifteen sances of central galvanization.*

CASE XCVIII.—W. R., 9 years of age, came into the Electro-Therapeutical Department of Demilt Dispensary, April 11, 1872. At the age of three the patient had

scarlet fever; this was followed by general prurigo that had never been relieved. The disease covered the back, abdomen, and legs. The itching was most severe. Sleep at night had for years been interrupted by this distress, and marks of scratching were everywhere seen. The disease was at its worst on the back.

Acting on the theory that the disease was of a nervous character, Dr. Woodruff referred the case to the Electro-Therapeutical Department, when treatment by central galvanization was begun and continued for two months. Towards the close of the treatment, June 1, little remains of the eruption were seen excepting on the back, and there was very little itching.

June 15.—The patient abandoned treatment; the recovery appeared to be satisfactory. We have no further intelligence of the case.

Dr. Sterling gives us the following case, the diagnosis of which was not fully clear to him:—

*General eruption with burning sensation of long standing—Some improvement under localized galvanization, and galvanization of the cervical sympathetic—Much greater improvement under central galvanization.*

CASE XCIX.—Mr. G., at the age of twelve, was attacked with an eruption all over the body, after sea-bathing. Treatment cured the eruption, but a burning, smarting sensation was left in the face, that always was increased on any excitement. Drinking a cup of tea or coffee, or entering a heated room, would bring on burning and smarting in the face, with very decided puffiness. Arsenic and various other remedies had been used faithfully.

May 1, 1871.—Treatment by galvanization of the sympathetic and localized galvanization was begun, and the result was satisfactory; but relapse occurred, and some months subsequently he was treated by central galvanization alone, with very great improvement. He still suffers from slight relapses that are always benefited by electrical treatment.

*Lichen.*—We have had no opportunity to treat a marked case of lichen; but there is every probability that electricity would accomplish as much in this affection as in the other symptoms of the so-called dartrous diathesis.

*Anæsthesia.*—For the curable cases of cutaneous anæsthesia, faradization is a specific, if any remedy can be said to be a specific for anything. Even cases that depend on incurable central lesion may improve very decidedly under treatment. In cases of paralysis of motion and sensation, the sensation may be partially or completely restored under electrical treatment, even when the loss of motion remains unchanged.

Anæsthesia is a condition for which the electric brush is particularly indicated (see chapter on Anæsthesia).

*Acne.*—If we were to judge from our own limited experience in the treatment of acne, we could not speak very encouragingly.

Our assistant, Dr. J. H. Sterling, informs us that one year ago a case

of hereditary acne indurata of the face and back, under his care, was treated by eighteen applications of central galvanization, without any other treatment, and the disease disappeared. The constipation and headache, which had been very distressing, were also relieved. Up to date (July, 1873) the patient was well.

*Acne Rosacea.*—Whether acne rosacea is different, pathologically, from ordinary acne or not, it certainly yields better to electrical treatment. On the theory that the disease may depend in some way on the digestive organs, central galvanization may be tried in connection with local treatment.

*Acne rosacea of long standing—Immediate improvement under localized galvanization with sponges and metallic electrodes.*

CASE C.—A medical gentleman, aged about sixty, in April, 1872, requested us to treat him for acne rosacea that had for some time caused him annoyance. The blood-vessels were considerably enlarged on both sides of the nose, the color was a decided red, and there was the usual thickening. The health of the patient was in other respects pretty good, excepting attacks of indigestion with acidity.

We began treatment with localized galvanization—with wet cloths and sponge, sometimes using a metal electrode, with a sharp edge. When the metal electrode—connected with the *negative* pole—was used, the dilated capillaries were electrolyzed under the negative pole, and gases escaped with a sound that could be easily heard. There was a tendency to reappearance of the dilated vessels, but after a few weeks' treatment they were entirely destroyed, leaving no scar or trace, and the color of the nose on both sides had disappeared. There appeared to be also a diminution of the hypertrophied tissues.

There has been, since that time, some return of the affection, but he is very much better than formerly. The habits of the patient were never intemperate, but he had always been accustomed to use more or less alcoholic liquors.

We have since treated another case of acne rosacea by the same method, and with results which, for the time, are most satisfactory. This case has been attended with itching that has been relieved, and the appearance of the nose has very rapidly improved.

*Psoriasis, and Pityriasis*, in their relation to electro-therapeutics, may be divided into three classes: (1) Those cases that are benefited up to a certain point. (2) Those cases that receive but little, if any, benefit. Judging from our own observations, we should say that the latter class (those who do not yield at all) are in the minority. Some cases progress very slowly, and need months of treatment. The negative pole of the galvanic current seems to be more efficacious in this disease than any other method. For the sake of economizing time, however, we frequently use both poles, with broad electrodes.

The results have not been very satisfactory. Even when decided

improvement takes place under long treatment, relapses may occur, and the cure has never in our hands been complete.

*Herpes—Herpes Zoster—Herpes Frontalis seu Ophthalmicus.*—Herpes, if not the most persistent, is, without doubt, attended by the most excruciating pain of the various neuroses of the skin. Whether its seat be the head, the trunk, or the extremities, the associated pangs are sometimes almost beyond human endurance.

Herpes is now generally regarded as subordinate to the existence of a neuralgic or rheumatic diathesis, and as originating in any cause which weakens the vigor of a nerve-trunk or its cutaneous branches: hence it would not be unreasonable to suppose that electricity in some one of its forms might prove of service.

The teachings of experience clearly attest its value in this complaint. The disease, it is true, runs an acute course, and, as a rule, recovery more or less complete follows in the course of a few weeks, but it is none the less incumbent to relieve, so far as possible, the acute sufferings that attend it.

The first two cases which we briefly record occurred in that part of the body—viz., the trunk—which is said to be the most frequent seat of the disease. The succeeding three of *Herpes frontalis seu ophthalmicus* are of somewhat greater interest, because of the comparative infrequency with which such cases are met, and of their great importance to ophthalmologists.

*Herpes thoracalis—Treatment by the faradic current.*

CASE CI.—Jane A., a dispensary patient, aged seven years six months, had suffered for several weeks from febrile symptoms and anorexia, and finally an herpetic eruption appeared on the chest and right side. The eruption increased and rapidly extended, until the thorax was nearly encircled. The pain from which the child suffered was very severe, and for forty-eight hours it had been continuous. We employed faradization (mildly), and were rewarded by an immediate relief of the neuralgic pains.

Four similar applications were subsequently given,—one on each alternate day; but there was no return of pain, and within ten days the eruption, which resembled aborted vesicles, had quite disappeared.

*Herpes sacralis—Treatment by the faradic current.*

CASE CII.—We were called, December 3, 1873, to see a gentleman, aged 34, who was suffering from an herpetic eruption over the region of the sacrum. The vesicles extended from the hip to the sciatic notch on the right side, and covered a narrow tract along the outer portion of the thigh, with clusters here and there to the external malleolus. The accompanying neuralgic pain was quite as severe as in the preceding case, and simulated actual sciatica. We placed the foot of the patient on a copper plate, to which the negative pole was attached, and with a mild faradic cur-

rent brought the whole hip and limb under the electrical influence. The effect was most grateful, and the relief afforded immediate.

The same method was repeated a number of times, and although the patient occasionally experienced twinges of pain, they were of little severity, and within a week ceased to annoy him.

Of *Herpes frontalis seu ophthalmicus* we have treated six cases by electricity, and always with the result of relieving the pain, and in three cases the course of the disease even was apparently modified.

*Herpes frontalis—Treatment by the galvanic current.*

CASE CIII.—A lady, aged about 60, and sent to us by Dr. C. R. Agnew, had suffered long and severely from herpes of the forehead and face. Acute and persistent neuralgia supervened, resisting all attempts at permanent alleviation. The galvanic current was locally and centrally applied, and resulted, in a few sésances, in relieving in a good measure the neuralgic pains. Ptosis of the right eyelid remained, however, in spite of the treatment by galvanization. Three local applications of the faradic current approximately restored the lost muscular power.

*Herpes frontalis—Alleviation of pain by the galvanic current, after failure of the faradic current.*

CASE CIV.—Mrs. L., aged 39, consulted us on June 10, 1874, and gave the following history of her case. Two weeks prior her attention was called to a small vesicular eruption on the left forehead, directly over the course of the supra-orbital nerve. Similar eruptions quickly followed, thickly studding the side of the head and face, and accompanied with much pain. A homœopathic physician had had the case in charge, and had succeeded in temporarily relieving the neuralgia only by the administration of morphine. When the patient fell under our observation she was suffering more than at any previous time, and, rather because of convenience than choice, we gently applied the faradic current to the affected and surrounding parts. It did not cause, either during the application or subsequently, any special modification of the distress. On the following day we resorted, as we should have done at first, to the galvanic current, making the applications locally, centrally, and in less than ten minutes the intense agony of the patient was almost completely relieved. She passed a very quiet night, but in the morning complained of some distress over and in the right eye and temple. She was immediately relieved by a second application, after which she was subjected to treatment several times, although she suffered but little, if any, and rapidly progressed towards recovery.

*Herpes frontalis—Treatment by the galvanic current—Immediate relief of pain—The course of disease apparently modified.*

CASE CV.—A third case of zoster frontalis, in the person of a female, aged about 35, fell under our observation on the 2d of June, 1874. The lady, who was a patient of Dr. Oliver White, first observed a slight eruption over the right eye. This rapidly spread over the whole side of the forehead, and the angle of the mouth was involved. The associated neuralgia was of the most excruciating and intolerable character. Dr. L. D. Bulkley was called in consultation, and advised the galvanic cur-



rent, a few applications of which rapidly and effectually relieved the patient of all pain, and greatly hastened recovery after failure of various local applications. The treatment was continued for some time subsequently, in order to make the scarring as slight as possible.

It will be observed that of the above cases the first two, in which the eruption was confined to the body, were relieved by the faradic current; and that the three following (herpes frontalis) yielded to the galvanic current.

From these and other cases the following conclusions seem to us legitimate:—

1. That the pain of herpes, no matter where the seat of the eruption may be, is generally susceptible of speedy and effectual relief by the use of the galvanic or faradic current.

2. That when the eruptions take place on the head—*herpes frontalis*—the galvanic current has greater power to relieve the pain than the faradic.

3. The electric treatment, besides relieving the pain of herpes, seems to shorten somewhat the acute stage, to break the force of the disease, and to modify the scarring.

*Ringworm.*—Common ringworm may yield to the galvanic current.

*Tinea circinata (ringworm) of more than two years' standing—Recovery follows one application of the galvanic current.*

CASE CVI.—A lady patient, aged 30, called our attention, casually, to a common ringworm, circular in shape, an inch and a half in diameter, and situated at about the junction of the shoulder and neck. The disease made its appearance more than two years prior in the shape of a slightly elevated spot which gradually enlarged to the above-named size. The part had begun to heal in the centre several times, and as often the process of repair would be almost complete, when the disease would take a sudden start and become as marked as ever. Finally, however, the centre of the eruption permanently disappeared and left a circular spot of clear skin, surrounded by a wide erythematous ring. This condition had remained stationary for more than a year. We applied to the diseased part a metallic disk sufficiently large to cover it completely, and passed for a few minutes a galvanic current of slight tension, but sufficient to create a decided burning sensation, and to appreciably affect the eruption. This was the only application, as immediately after the patient left the city. A month afterwards, however, she presented herself, but with no vestige of the ringworm. It began to disappear almost immediately after the treatment, and within two weeks the skin was quite clear. To this date, two and a half years since the application, there has been no reappearance of the eruption.

*Scleroderma.*—This disease of the skin, usually so obstinate to recognized methods of treatment, may be treated by strong localized galvanization with considerable benefit. Fieber, of Vienna, records a case

where peripheral galvanization combined with galvanization of the sympathetic were very effective. In a case that we saw with Dr. Piffard, and for a time treated with him, a very persevering use of the galvanic current had a decidedly beneficial effect.

*Chromatogenous Diseases—Leucoderma, Melanoderma.*—The chemical or catalytic action of the galvanic current is theoretically indicated in chromatogenous or pigmentary diseases. With leucoderma or whiteness of the skin and ephelis or sun-burn, and in lentigo or freckles, no experiments, so far as we know, have yet been made. Dr. Wm. R. Fisher, of Hoboken, has treated a case of *melanoderma* of the face by the galvanic current, and gained a complete cure. The spot, which was about half an inch in breadth and three quarters of an inch long, looked like a spot of mud on the cheek. Through the courtesy of Dr. Fisher we had opportunity to see this case both during the process of the treatment and after recovery.

### *Elephantiasis.*

*Elephantiasis of the legs, over two years' standing, attended with ulceration and great pain—Relief of pain—Removal of the elephantine skin and very remarkable reduction in the size of one leg under localized galvanization—Subsequent death of patient from exhaustion.*

CASE CVII.—Mr. P., an Englishman of middle life, a man strong and vigorous beyond the average, a distiller of oils by occupation, returning from his daily duties on the evening of February 22d, 1870, observed, on removing his socks, a small blister on the inner side of the left ankle. The next day he called on his physician, Dr. Rotton, under whose care he remained for one year and more.

The disease spread over the *left* foot and ankle, and in about two months the right foot was similarly attacked. The blisters as they ruptured left inflamed and angry surfaces in their track. The disease involved the surface of the feet, and both legs up to the knees. The treatment carried out by Dr. R. was mainly of a tonic and alterative character, with local applications of glycerine, carbolic acid, and lead wash. At one time Dr. Johnson saw the case, confirmed the diagnosis of elephantiasis, and rendered a diagnosis positively unfavorable.

We first saw the case by request of Dr. R. in May, 1872. At that time the right leg below the knee measured *twenty-five inches* in circumference, and it was covered all over with elephantine skin, excepting an ulcerating surface below the ankle. This ulcer was treated with charcoal poultice and discharged freely. The left leg was not greatly enlarged, but was red, angry, and inflamed, and kept up an incessant discharge from the surface.

The patient *suffered horrible agonies*, so that at night the neighbors were disturbed by his howling. He was unable to move from the sofa on which he sat, and where he worked at his newly-learned trade of cleaning gloves.

By our request Dr. E. Mann at first undertook the experimental treatment of the case by electricity. We had never known of elephantiasis being treated electrically,

and gave an unfavorable prognosis, and were indeed inclined not to attempt it ; only by the earnest request of the patient and his physician we decided to try and see whether we might give him some relief. Localized *faradisation*, at first tried, accomplished nothing, and, so great was the anæsthesia, was not felt by the patient.



FIG. 104.

Elephantiasis of legs before treatment by electricity.

Localized *galvanization*, by means of wet sponges, and both poles with zinc-carbon battery of sixteen cells, was appreciably felt, and very soon began to relieve the pain.

The applications were from ten to thirty minutes in length.

After two months' treatment the elephantine skin on the left leg was removed, the pain had ceased, and the leg was reduced in circumference from *twenty-five to seventeen inches*. The ulcerated portion below the ankle was also nearly well.

The electrical treatment was then discontinued for several months. During the latter part of this time there were evidences of relapse and reappearance of ulcers and pain. The case was seen at various stages by a large number of the profession.

The patient subsequently relapsed somewhat on a discontinuance of the treatment ; was again treated, though with less benefit, by our assistant, Dr. Sterling. Among other methods central galvanization was tried, but without perceptible effect. In the course of a year the patient died exhausted.

*Alopecia*.—In this condition, local galvanization has been used with some benefit. Our own observations in this particular affection have not been very extensive.

The question that has been often asked us, whether parasites on the skin can be killed by a current that the patient can easily bear, we are unable to answer.

*Permanence of the Results.*—The very natural question, whether the results obtained by electricity in diseases of the skin are more permanent than those obtained by ordinary methods, the future must answer. That relapses may occur after a cutaneous disease has even yielded to electrical treatment, already has been demonstrated. To what extent central galvanization and general faradization combined with local treatment can control the diathesis must be ascertained by patient and persistent experiment.

That the results of electrical treatment are, to say the least, as permanent as those derived from the accepted methods, and that after the accepted methods have partially or entirely failed, electricity, either alone or in conjunction with the accepted methods, may succeed, we have satisfactorily established.

## CHAPTER XXVI.

### DISEASES OF THE ORGANS OF DIGESTION.

**AMONG** the diseases of the organs of digestion for which electricity has been successfully employed, are *dyspepsia, jaundice, constipation, chronic diarrhœa, gastralgia, abdominal neuralgia, vomiting or regurgitation, flatulence, and sea-sickness.*

*Electro-Diagnosis.*—Irritable conditions of the stomach, liver, and intestines are sometimes revealed by their sensitiveness to the electric current. Pains must be taken to distinguish the sensitiveness of the skin from that of the internal organs.

An anæsthetic condition of the liver is sometimes exceedingly marked. In several of our cases the whole power of the faradic apparatus was not painfully felt, when localized through the liver by large sponge electrodes. Irritability or ulceration of the large intestines is sometimes indicated in a very marked manner. For the diagnosis of the diseases of these organs, the faradic current, on account of its superior mechanical effects, is preferable to the galvanic.

In nervous dyspepsia there is frequently a peculiar and very unpleasant tenderness in the epigastric region, so that only a very mild current can be borne. In some cases a thrill, with a sinking sensation, is felt when the electrode with a strong current is passed down the spine; in other cases the application of a strong current at the cilio-spinal centre, or on the crown of the head, causes a feeling of nausea. The spinal irritation, on which nervous dyspepsia so frequently depends, is indicated by tenderness of the dorsal vertebræ, as revealed by pressure or application of the current.

*General Principles of Electrical Treatment.*—Electrical treatment is serviceable in the diseases of the organs of digestion in two ways: *First*, by improving the nutrition of the tissues of the organs; *Secondly*, by improving the nutrition of the brain, spinal-cord, sympathetic, and entire nervous system. The tonic influence on the nervous system may be obtained by central galvanization, and by general faradization.

The mechanical influence on the tissues of the viscera may be ob-

tained by general or localized faradization. A fundamental fact of great importance in the treatment of disorders of the digestive tract is this, that *for applications to the abdominal viscera, stomach, spleen, liver, intestines and uterus, the faradic current is usually preferable to the galvanic.* The reason for this is that the faradic current acts more vigorously on the muscles than the galvanic, and therefore produces more powerful *mechanical* effects, with passive exercise of all the deep tissues. It may be safely said, then, that we know of no treatment more sure to relieve the leading and concomitant phenomena of dyspepsia as general faradization and central galvanization. In connection with this we sometimes use galvanization of the sympathetic, the pneumogastric, and spine. General faradization relieves nervous dyspepsia, not so much by the virtue of its influence on the stomach—although it directly affects the stomach—as by its influence on the nervous condition of which the dyspepsia is a symptom.

The number of our cases in which dyspepsia was the only symptom was comparatively small; the number in which it was a prominent accompanying symptom was quite large. Most of the cases of hysteria, nervous exhaustion, and hypochondriasis, and very many of the cases of neuralgia and paralysis, were more or less complicated with dyspeptic symptoms. Relief of dyspepsia is one of the earlier signs of improvement under electrization, even when treating cases in which it is merely an incidental condition.

The stomach and liver may be indirectly galvanized through the pneumogastric in the neck; the stomach, liver, spleen, kidneys, and intestines may be directly faradized by applying large electrodes with very fine pressure over the back and abdomen, so as to pass the current directly through the organ that we wish to affect. Except in cases of disease, these organs will bear strong currents without severe discomfort. Either stable or labile applications may be used, without regard to the direction of the current, from three to ten minutes, or even longer.

*Prognosis.*—For the temporary or permanent relief of nervous dyspepsia, the prognosis under the treatment above indicated is exceedingly favorable, and the *results obtained by general faradization and central galvanization alone are some of the most remarkable in therapeutics.* Cases of nervous dyspepsia, with their manifold complications, are on the whole the best tests that can be offered for this method of treatment. Not only are the purely dyspeptic symptoms relieved, but there is great improvement in sleep, and in strength of muscle and brain, and in some cases very marked increase in weight. Relapses

are not unfrequent in this disease, especially under bad hygiene; for with many the tendency to nervous dyspepsia is hereditary, and is continually liable to manifest itself.

*Dyspepsia, accompanied by a voracious appetite and a constant burning in the stomach—Approximate recovery under treatment by general faradization.*

CASE CVIII.—The case of Mr. S., aged 31, presented symptoms of the old-fashioned variety of indigestion. His appearance did not indicate any special or annoying disease.

A year previously he began to experience an uneasy feeling in the epigastric region after eating a hearty meal. This symptom gradually became more aggravated, until it was a source of serious annoyance.

He had been advised to limit himself to a spare diet, and had attempted to regulate the quantity and quality of his food. In this he failed on account of another symptom, which before had escaped his observation. We refer to boulimia—in other words, a voracious appetite, which refused to be controlled. The enormous amount of food which he devoured at every meal was but partially digested. A considerable portion was occasionally vomited. When his meals were withheld a short time, he experienced an indescribable “sinking” at the stomach, impelling him to seize voraciously on articles of food. He complained especially of a constant sensation of heat, or a burning pain in the epigastrium, which was aggravated by the ingestion of food. We ascribed this symptom to an excessive vascular irritation of the mucous membrane of the stomach.

An unequal circulation was manifested by cold extremities during the day, and hot feet at night.

Derangement of the hepatic function was evident by the light clay-colored stools, while the urine was invariably almost colorless. The patient was accustomed to the habitual use of alcoholic stimulants, but never to the point of intoxication. He had used strong coffee and tea to excess, but had for some months abstained from them altogether. The faradic current was acutely felt over the stomach. Over the body generally, however, he bore a current of more than ordinary intensity. Three applications given in the course of a week appreciably lessened the irritation of the diseased organ. This effect was evinced by a decrease in the burning sensation, which was mentioned as a disagreeable and marked symptom. The vomiting was effectually controlled after two weeks of treatment. Twenty applications administered during a period of two months resulted in an approximate cure.

The voracious appetite was in a great measure subdued, and it was only after some indiscretion in diet that any of the old local symptoms returned sufficiently to annoy the patient.

*A case of indigestion and excessive vomiting associated with anæsthesia and weakness of right side—Approximate recovery of indigestion, etc., under galvanization of the sympathetic, pneumogastric, and relief of the anæsthesia under general faradization.*

CASE CIX.—Miss C., aged 23, came to us in October, 1870, with the following history: She suffered during childhood for several years from chorea of the right side, which at the age of twelve entirely disappeared.

She then enjoyed fair health until the age of 21 years, when a condition of indigestion supervened that was fearful in its effects. Hardly anything could be retained upon her stomach, and during the winter she wasted almost to a shadow, and her life was despaired of. Under galvanization of the sympathetic and pneumogastric, her dyspeptic symptoms improved, and the vomiting became decidedly less. After two months of this treatment, she had increased in weight to her normal standard, and when we last saw her, she was able to retain the greater portion of the food ingested. Since the digestion began to improve, however, the left side of the body became markedly anæsthetic, cold, and greatly deficient in strength. The opposite side was slightly affected. General faradization repeated six or eight times almost completely relieved these symptoms.

*Dyspepsia of many years' standing—Great improvement under general faradization, and increase in weight of thirty pounds.*

CASE CX.—Mr. T——, a bookseller, aged 31, stated that for a number of years he had suffered from chronic dyspepsia, which had rendered his life miserable. He had lost much in flesh. Although 5 ft. 8 ins. in height, his weight was but about one hundred pounds. He complained of regurgitations from the stomach of an intensely sour liquid, and on rising in the morning he was often troubled with pyrosis. Tympanitis was a frequent symptom, and oftentimes the accumulation of gas within the stomach embarrassed the respiration and disturbed the action of the heart. Treatment was commenced about the middle of October, 1866, and continued for four weeks, general faradization being applied three times each week. The daily regurgitations, the tympanitis, and pyrosis gradually ceased to annoy him; and after the tenth application, he informed us that during the month he had increased in weight some fifteen pounds.

About the beginning of January, 1867, he called upon us, stating that his health was excellent, and that his total increase in weight, since he first commenced treatment by electricity, was some thirty pounds. He said that he did not feel that his digestive organs were as strong as they had been before he was attacked with dyspepsia, but they had ceased to give him any considerable annoyance.

*Nervous dyspepsia, associated with periodical attacks of headache and vomiting—Approximate recovery and rapid increase in weight follow general faradization*

CASE CXI.—A young man consulted us in the fall of 1866 for a persistent form of nervous dyspepsia.

He was of a weak nervous organization, and presented a remarkably anæmic and emaciated appearance. Every month or six weeks he was prostrated by a severe attack of headache and vomiting, from the effects of which he would not recover for several days. In administering a general application of the faradic current, it was found that the liver was relatively the most sensitive to its influence. So exhausting was the sensation produced by the electricity in this organ, that very decided symptoms of faintness followed. He soon rallied from its effects, and when he visited us two days subsequently he expressed himself as having experienced very marked and grateful relief. At each sitting he was able to bear a more intense current over the digestive organs and body generally. The beneficial effects of the applications were soon manifest by a more natural and lively appetite, relief of constipation, by greatly



increased vigor of mind and body, and by the non-recurrence of his usual paroxysm of headache and vomiting. The first application was given October 24, and the fifteenth and last in the early part of December. During the treatment the weight of this patient increased from 106 to 115.

A number of cases in which nervous dyspepsia was a symptom will be found under hysteria and allied affections, neuralgia and paralysis.

*Constipation, Chronic Diarrhœa, and Jaundice.*—*Constipation*, associated with and constituting a part of nervous dyspepsia, is, like dyspepsia, disposed to yield rapidly, and often permanently, to electrization. Next to insomnia, it is the symptom first to yield, after general faradization is used, even though there may be subsequent relapse. Very many of the cases related under dyspepsia, hypochondriasis, hysteria, and nervous exhaustion, were to a greater or less extent troubled with constipation, even when this symptom was not specified; and in the majority of cases there was important relief.

The relief is sometimes merely temporary; relapses are most likely to occur in those cases that are of a hereditary, or at least life-long character.

It not unfrequently happens that a strong application is followed the next or even the same day by a freer alvine discharge than usual. Constipation, much more frequently than is supposed, depends on an irritable, exhausted, or congested condition of the spinal cord. That myelitis and the more serious lesions of the spinal cord are accompanied by a deranged condition of the bowels, either constipation or diarrhœa, is fully recognized; it is not, however, so well understood that *spinal irritation*, even in its milder degrees, may have constipation for one of its symptoms, and that this symptom will disappear with the removal of the cause, by treatment directed to the spine. For those cases that result from incurable disease of the brain or spinal cord only temporary relief can be obtained. In such cases relapse usually occurs as soon as the treatment is discontinued. Very obstinate and life-long cases of constipation sometimes are not benefited by any form of electrical treatment.

Electrization may be said to relieve constipation in several different ways:—

1. By its general tonic effects on the system at large, on the same principle that it relieves nervous dyspepsia.
2. By its tonic effects on the central nervous system, and especially on the spinal cord. On account of the fact that very many cases of constipation depend on a morbid condition of the cord, special atten-

tion should be given to the spine, whatever may be the method of electrization employed.

3. By its direct effects on the organs of digestion. The mechanical action of the faradic current especially gives tone to the stomach, liver, and intestines, markedly increases the hepatic and intestinal secretions, and aids the peristaltic action of the intestines.

In *jaundice* the results of our limited experience have been more favorable than the reverse. In *chronic diarrhœa* we have succeeded in a number of striking instances.

The treatment of all these conditions is worthy of far more attention than it has thus far received from electro-therapeutists.

*Habitual constipation for fifteen years—No permanent benefit from medication—Rapid improvement under general faradization—Relapse.*

CASE CXII.—Mr. N., aged 30, a printer employed in the office of the *New York Times*, was sent to us by Dr. St. John Roosa. For fifteen years he had suffered from constipation. So persistent were the symptoms, that neither well-directed medication nor such hygienic measures as he could command were of any avail.

The appetite was good, and the sleep moderately sound and refreshing. The patient complained of a sense of weight or oppression in the abdomen, of flatulence, and occasionally of a slight feeling of nausea.

The evacuations often came away in knotty lumps, after much straining and an unpleasant distension of the anus. As a consequence of this torpor or want of susceptibility of the intestines, his health had become considerably impaired. He complained of a general feeling of malaise and a disinclination to engage in any active effort. Above all, however, he suffered continually from most painful mental depression. The monotony and confinement of his occupation, together with the unnatural method of life of working at night and sleeping during the day, doubtless served to aggravate the character of his disorder. He received only three applications of the faradic current, which resulted in an extraordinary improvement in his general symptoms. After the first séance the bowels moved freely, and continued to do so every day while he visited us. He was completely relieved of his mental and physical depression, and in every respect was more vigorous than for many years before.

The bowels continued regular for several months, when the old symptoms gradually returned. The patient again applied to us for treatment, and was relieved as effectually as before.

*Obstinate constipation relieved by a few applications of the faradic current.*

CASE CXIII.—Through the kindness of Dr. Howard Pinckney we treated an obstinate case of constipation in a lady aged about 30, who also suffered from severe menorrhagia and nervous exhaustion. A few applications of general faradization—the current being directed more particularly, however, to the intestinal tract—relieved this condition so decidedly, that it was unnecessary to continue the treatment. A year subsequently a single application relieved the patient on a return of the old symptoms.

In some cases of very obstinate constipation it is of advantage to localize the current by *internal applications*. This may be accomplished by means of a rectal electrode (Figs. 106 and 107). This may either be non-insulated, or insulated up to a point near the tip, and may be double or single. A *very powerful current may be borne in the rectum without discomfort*. The other pole may be applied at different points over the abdomen.

With the double rectal electrode, as with double electrodes of all kinds there is so small a portion of the body interposed that the resistance is very feeble and only a slight current will be borne.



FIG. 105.

Rectal Electrode—non-insulated (Kidder).



FIG. 106.



FIG. 107.

Double Rectal Electrode (Galvano-Faradic Mfg. Co.)

In a case of obstinate constipation following parturition we tried in succession external and internal faradization and external and internal galvanization with strong currents without effect.

*Ileus (Invagination).*—Althaus reports two cases where powerful faradization availed to cure constipation when the ordinary remedies had been tried in vain. The negative pole was applied to the spine,

and the positive passed over the abdomen in the region of the large intestine. In three minutes a very abundant evacuation appeared.

The second case was severe, but not as long standing as the other. The patient passed much blood at stool, and was fast becoming exhausted. The same application brought relief, though not so speedily as in the preceding case. In two cases of ileus that we treated in this way there was relief.

Dr. Clemens, of Frankfort, states that he has successfully treated invagination by first administering one or two tablespoonfuls of metallic mercury, which settled down to the seat of the invagination. The negative electrode was applied over the supposed seat of the disease, and the positive in the rectum. Voltaic alternatives were used.\*

*Chronic diarrhœa of six months' standing, associated with general neuralgia—Marked tenderness over the transverse colon—Treated by general faradization, with special reference to the tender spot—Recovery in three weeks.*

CASE CXIV.—A lady, aged 35, sent to us by Dr. H. H. Gregory, for a general neuralgia, from which at times she suffered excessively. The faradic current was applied over the whole body, and produced no discomfort, excepting when it was sent through a certain part of the intestinal tract.

This tender spot was located on the right side, directly over the transverse colon. Over no other portion of the abdomen was she at all sensitive to the electricity, but at this point a very moderate current produced a disagreeable, sharp, burning pain, similar to that caused by making the application to a raw surface. Upon inquiry, the patient stated that for six months she had been annoyed by a diarrhœa, which persisted in spite of persevering and judicious medication. She was obliged to exercise the utmost caution in her diet, for the least indiscretion in eating was certain to aggravate her disorder.

We now directed the applications more especially to this *tender spot*, and soon observed some amelioration of her diarrhœal symptoms. The stools assumed a firmer consistency and a more healthy color, and in proportion as she improved in these respects the tender spot became less sensitive to the influences of the electric current. Eight applications, extended over a period of three weeks, resulted in complete recovery.

*Diarrhœa of several months' standing in a lad of twelve years, caused by exposure to cold—Recovery under ten general faradizations—Increase in weight.*

CASE CXV.—J. W., aged twelve years, was annoyed by an excessive looseness of the bowels, which had persisted for several months in spite of every form of medication that had been tried. He was of a delicate constitution, but until this attack of diarrhœa he had always enjoyed a good degree of health. His mother attributed his disorder to exposure during a cold, damp day, at a time when his system was a little below par from too close confinement in the school-room.

A moderate amount of food caused no discomfort, but his power of assimilation

\* Althaus, op. cit., p. 603.

was considerably impaired, as shown by the great quantity of alinent that passed his bowels daily. Ordinarily he had five or six evacuations during the twenty-four hours; but if he indulged to any extent in athletic exercises the symptoms became more urgent.

On one occasion, after indulging for an hour in a game of ball, he was annoyed during the night by nearly a dozen evacuations, which were attended with considerable pain. As might be inferred, this constant drain upon his system had still further decreased his limited stock of vitality, and he had lost within three months some twelve pounds in weight.

The first four applications worked no important change in his general condition.

After the fifth visit there were manifest signs of improvement. During the twenty-four hours following he was compelled to evacuate his bowels but three times, instead of five or six. The improvement continued after each subsequent application, until the number was reduced to one daily. The fœces were of a firm consistency and unmixed with undigested food. The evacuations caused no suffering, and, more than all, he had gained nearly six pounds in weight. He could indulge in all the ordinary sports of his school-fellows without any evil consequences following.

The patient was under treatment nearly a month, and the number of applications administered was ten.

*Chronic diarrhœa with excessive pains in back and abdomen—Great debility—Very great improvement from general faradization.*

CASE CXVI.—Miss I., a lady 30 years of age, was referred to us by Prof. J. T. Metcalfe, Oct. 21, 1869, to be treated for chronic diarrhœa of four years' standing, alternated with some anæmia and muscular weakness. The discharges, sometimes several daily, were frequently followed by severe pain. Debility was so excessive that she was over-fatigued by a walk of a quarter of a mile. Her appetite was capricious and digestion imperfect, and the condition of her bowels made necessary constant caution. The patient referred her difficulties to exhaustion caused by attendance on an invalid sister.

Electric examination revealed a marked tenderness over the transverse colon, which varied at different times.

The patient was treated by general faradization, at first cautiously, but soon as she proved able to bear it, with greater freedom, by intervals, for three months, the applications being made every other day. Improvement began early, and its march was continuous and mostly uniform. The discharges were gradually reduced in frequency, with relief of the accompanying pain, though two slight relapses occurred from imprudence at the table. The excessive pain in the back was relieved temporarily with each application. From week to week her strength improved, and at the close of the treatment she could walk two miles with pleasure. The increase in size and hardness of the muscles of the upper and lower limbs was palpable. Occasional attacks of looseness of the bowels annoyed her even then, but they were not accompanied by the severe pain, and were quite readily checked before they had time to impair nutrition or reduce the system.

A letter received from the patient in September, 1869, reported that in the main she had retained the improvement derived from the treatment.

In this case very strong and quite protracted applications were given, and with

considerable thoroughness. Only the faradic current was employed, since it seemed to meet all the indications. The temporary effects of general faradization—relief of pain, with a feeling of warmth and exhilaration—were strikingly observed after each application.

That the opposite symptoms—diarrhoea and constipation—are treated successfully by electricity need surprise no one who thoroughly comprehends the fact that electrical treatment improves nutrition and so may be used to combat any diseases that depend on depraved nutrition, whatever the symptoms by which the depraved nutrition manifests itself.

*Jaundice with debility of six months' standing—Rapid recovery under general faradization.*

CASE CXVII.—Mr. B., aged 28, had suffered at intervals from jaundice associated with excessive physical prostration for nearly six months.

His bowels were obstinately constipated, and had been so during all this period of bodily derangement. He had been physicked at various times, and most thoroughly by calomel podophyllin and other cathartics, and had been constantly under the influence of tonic remedies. These efforts had resulted only in temporary relief, and at the time he applied to us for treatment the patient's appearance was typical of an aggravated case of jaundice.

We submitted him on alternate days to general faradization with rapid and decided effect. The constipation was first relieved, and then followed an increase of appetite; at the same time his skin became clearer, and he increased both in strength and weight.

The result was complete recovery within a month.

(For Gastralgia see chapter on Neuralgia.)

*Regurgitation and Vomiting.*—For those cases of vomiting that are of an obviously nervous character, galvanization of the sympathetic and pneumogastric, or strong faradization through the stomach, is sometimes of important service. Successful results have been obtained by Pepper and Bricheteau. The latter treated with success three cases of vomiting of pregnancy. His method of application was to place the electrodes on the epigastrium at the commencement, middle, and close of the meal.

It is well in such cases, especially if they are obstinate, to try a variety of methods: galvanization of the sympathetic and vagus, and of the spine, faradization through the stomach with a strong stable current, and general faradization.

Dr. F. D. Lente, of Cold Spring, informs us that he has met with excellent success in the treatment of vomiting by faradization. In some cases the effects are immediate.

*Flatulence.*—Flatulence is a symptom of disorder of the digestive organs that very readily yields to electrical treatment. It demands the same treatment as dyspepsia and constipation. Those very frequent cases that depend on spinal irritation and congestion, and on hysteria, need central galvanization or general faradization; cases that depend on an attack of acute indigestion may be advantageously treated by internal applications, one pole being applied to the rectum by the rectal electrode, and the other to the spine or abdomen.

Flatulence was a symptom in very many of our cases of dyspepsia, hysteria, and spinal irritation, and almost uniformly it temporarily or permanently yielded.

*Sea-sickness.*—In October, 1869, Mr. Le Coniat, a French surgeon, presented a method of treating sea-sickness, before the New York Medical Association. Subsequently a detailed account of the method was published by Dr. Dwinelle,\* who had experienced the good effects of the treatment on his own person in a passage across the Atlantic.

His method was to first apply a quantity of solution of atropine—one grain to the ounce—to the epigastrium, then to apply a flat disk, connected with a faradic apparatus, over the pyloric extremity of the stomach, while a moistened sponge connected with the positive pole was passed over the surface, from the cardiac to the pyloric orifice.

Vigorous contractions of the muscles appeared during the applications, which were followed by agreeable repose.

Le Coniat claims to cure by this method ninety per cent. of his cases.

The statements made by Coniat and Dwinelle lose much of their scientific as well as of their practical value, from the fact that the atropine was combined with the faradization.

There is little doubt that the passage of the electric currents through the body facilitates the absorption of liquids, placed beneath the electrodes; moreover, it is well known that the skin is capable of absorbing liquids without the aid of the electric currents. The quenching of thirst by bathing is a very familiar illustration.

Then again, atropine is a remedy so powerful that  $\frac{1}{100}$  or even  $\frac{1}{300}$  of a grain is sufficient to powerfully affect the nervous system, when administered hypodermically. Furthermore, it is a remedy for sea-sickness and sick-headache, as has been shown by experiments of ourselves and others who have employed hypodermic injections of this remedy combined with morphine. A dose containing  $\frac{1}{100}$  of a grain of atropine and  $\frac{1}{4}$  of a grain of morphine is sufficient in certain cases to relieve the

\* New York Medical Journal, 1869, p. 390.

nausea and vomiting, and produce sleep—the same effects that are produced by the operation of Le Coniat.

From all these considerations, taken in connection with the further consideration that sea-sickness is probably not a disease of the stomach alone, but of the central nervous system, of which the nausea and vomiting are frequent but by no means necessary symptoms, we are strongly inclined to the belief that the results obtained by Le Coniat's procedure could have been obtained with much less difficulty by hypodermic injections of atropine.

The true way to settle the question experimentally would be to treat a large number of patients by all three different methods—some by the procedure of Le Coniat, others by the same method without the atropine, and others by hypodermic injections of atropine.

Electricity must be proved to have some very potent influence over sea-sickness, in order to persuade patients and physicians to attempt its use on shipboard. A surgeon in the United States Navy reports to us that he has had good results in the treatment of sea-sickness by faradization.



## CHAPTER XXVII.

### DISEASES OF WOMEN.

THE diseases of female sexual organs for which electricity has been proved to be of service are the symptoms of *amenorrhœa*, *dysmenorrhœa*, *menorrhagia*, and *leucorrhœa*, although some important results have been obtained in *irritation* and *inflammation* of the *ovaries*, *chronic metritis*, *enlargements*, *displacements*, and *atrophy of the uterus*.

*Amenorrhœa*, *dysmenorrhœa*, *menorrhagia*, and *leucorrhœa*.—These symptoms of disease are of course most amenable to electrization when they are not dependent on any severe or incurable pathological condition, but are merely indications of functional derangement. The inconsistency and uncertainty of the results of the treatment of these symptoms by electricity is entirely explicable to all who are conversant with uterine pathology; cases that are indiscriminately treated by any method must, of course, frequently result in a manner very disappointing. While this is true of all the so-called functional diseases of all parts of the body, it is especially so with regard to the diseases of women.

*Treatment of Diseases of the Uterus*.—Local, central, and general treatment may be employed. The local treatment may be either external or internal.

*External Method*.—Externally, the uterus and its appendages may be electrized by placing one pole with firm pressure over the hypogastric region, and the other over the lumbar region of the spine.

This method is sometimes as effective as internal applications, and, in virgins at least, should always be tried at first. In this method benefit is derived partly from the effect of the current on the lower part of the spinal cord and the abdominal ganglia of the sympathetic.

*Internal Method*.—Electric currents may be localized in the female organs of generation in a variety of ways. One pole may be applied to the os by means of an insulated electrode with a metallic bulb (Fig. 109), while the other, with a broad electrode, is applied to the back, or on the hypogastric region, or over one of the ovaries. Instead of a metallic bulb the uterine electrode may be composed of branches to

clasp the cervix. A much stronger current can be borne at the cervix than would be supposed.

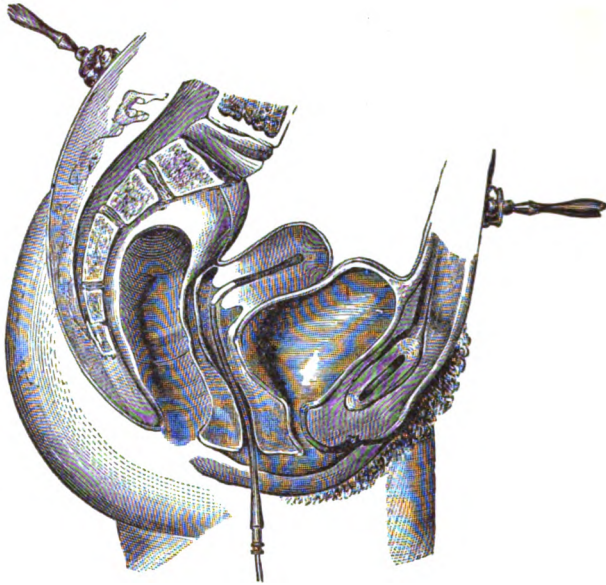

FIG. 108.

**FARADIZATION OF THE UTERUS.**—One of the poles is connected with a bifurcated electrode, one branch of which is placed on the lumbar, and the other on the hypogastric region. The other pole is applied in the cervix (or at the os) by an insulated uterine electrode. (The normal position of the uterus is after Wieland and Dubrisay.)

A method of faradizing the uterus is represented in the accompanying cut (Fig. 108).

For intra-uterine faradization we have devised an *intra-uterine electrode* which is represented in the cut. The basis of the instrument is similar to Sims's sound. This is insulated with varnish up to within three inches of the extremity; the handle is of hard rubber, and is provided with a hole and screw for fastening the connecting wire of the apparatus, and a button connected with a spring, by means of which the connection of the current can be made or broken at pleasure. The manifest advantages of the interrupter, which is similar to that of the universal electrode holder (Fig. 110), is that it dispenses with the necessity of waiting until the instrument is *in situ* before connecting it with the apparatus, and that it makes it convenient to give rapid

interruptions and to instantaneously suspend the treatment when required.

When properly curved, this electrode may be used for the larynx.

Fig. 111 represents a double intra-uterine electrode which allows one pole to act on the uterine canal and the other on the os externum.

Fig. 112 represents the *double uterine electrode* of Duchenne.\*



FIG. 109.  
Uterine Electrode (Kidder).



FIG. 110.  
Beard's Intra-Uterine Electrode (Tiemann & Co.).

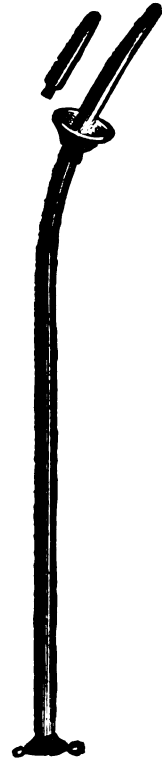

FIG. 112.  
Double Intra-Uterine Electrode (Galvano-Faradic Mfg. Co.).

This is composed of two plates, connected with flexible wires, which pass through a sound, but are insulated from each other.

On pushing in the wires slightly at the point where the connection with the apparatus is made, the poles separate as in Fig. 112. On again

\* De l'Electrisation Localisée, p. 89.

drawing them in, they close as in Fig. 113. The instrument, which is the same in principle as the *double vesical electrode*, is introduced while closed, as in Fig. 113, and opened so as to clasp the neck of the uterus. One of the insulated wires is connected with the positive and the other with the negative electrode. By this means the current is very closely localized in the neck of the uterus.

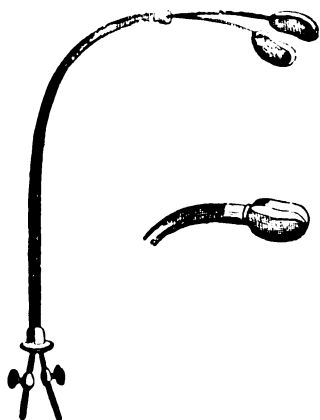

FIG. 112.

FIG. 113.

Duchenne's Double Uterine Electrode.

Concerning these internal applications of electricity to the uterus, it may be remarked:—

*First*—That in those cases where local treatment is indicated, applications to the *cervix* or in the *uterus* are frequently much more efficacious than external applications, even with the strongest currents. For this reason it is necessary, even with virgins, to insist on internal treatment, especially after external treatment has failed. The uterine electrode (Fig. 109) can usually be introduced into the vagina as readily as the finger. The intra-uterine electrode cannot well be introduced without the aid of a speculum.

The other pole may be applied to the back or abdomen by means of a flat metallic surface or plate covered with moistened sponge.

*Secondly*—*Internal electrization is not so painful as external.* Powerful currents can be borne at the cervix and in the uterus for a long time without inconvenience. Patients usually complain more of the pain beneath the electrode which is applied on the back or abdomen, even when the negative, which is the stronger and more painful, is applied internally.

Tripier,\* who has carefully studied the subject of localized faradization of the uterus, is accustomed to place one pole in the bladder by means of a vesical insulated electrode, or in the rectum by a rectal electrode.

In some cases he connects one of the poles with a bifurcated electrode, a branch of which is placed on each iliac region, while the negative pole is connected with an insulated rectal electrode in the rectum.

*Fourthly*—*Either current may be used.* The galvanic as well as the faradic current may be localized in the uterus, and sometimes it is much more effective. The danger that the chemical action of the galvanic

\* Annales de l'Electro-Thérapie, 1863, p. 205 et seq.

current will injure the lining membrane of the uterus is but slight, provided too strong currents are not used, or the pole is not allowed to rest a long time without breaking the circuit.

*In all these methods of application either direction of the current may be used.* (See p. 244.) In the treatment of uterine congestion and engorgement, the positive pole is slightly preferable to the negative pole, for the reason that it has a more powerful contracting influence on involuntary muscular fibres.

The vagina may be treated by a metallic vaginal electrode (Fig. 114), with which either the positive or negative pole may be connected. This is useful in vaginal *leucorrhœa* and *prolapsus*.

For these local applications either the galvanic or faradic currents may be used; but the faradic is usually preferable, because in the majority of cases for which electricity is applied to the female sexual organs, *mechanical* more than chemical effects are indicated. Especially is this the case in amenorrhœa. Furthermore, the currents may be stable or labile, uniform or increasing, according to the indications. Local applications to the uterus, whether external or internal, may be continued for from five to fifteen minutes. Several methods may be tried at each sitting.

*General and Central Treatment.*—But very many, perhaps the majority of cases of functional disease of these organs, require *general* as well as localized electrization. There is no department in which so many mistakes have been made by too exclusively local treatment as in that of gynæcology. *No case of functional disturbance of the uterus should be abandoned by the electro-therapeutist until he has faithfully tried general as well as external and internal localized electrization.* To treat symptoms of central or constitutional disturbance by merely local electrization is illogical in theory and unsatisfactory in practice. All the organs of generation in woman as well as in man can be affected by galvanization or even faradization along the spine. A strong evidence of the beneficial results of general faradization in these cases is the fact that patients undergoing treatment frequently remark that their menses are in some way affected. In some cases they are brought on before their time, in others much increased in quantity. So frequently does this happen that we prefer on the whole to suspend the treatment during the menstrual periods in those cases where no therapeutic effect is desired on the sexual organs.



FIG. 114.

Vaginal  
Electrode  
(Kidder.)

The *time* of making the applications is not unimportant. It is an advantage, in amenorrhœa at least, to concentrate as many applications as possible during the few days that precede the appearance of the menses. And yet the advantage of this is hardly as great as has been supposed. The great thing in all but recent and temporary cases is to remove the anæmia or chlorosis, or nervous exhaustion with which the menstrual disorder is associated, and of which it is a prominent factor. Another suggestive consideration is that the menstrual flow may be brought on or increased through *reflex action* by localized electrization of other and distant portions of the body, as the hands, feet, chest, etc.

*Static Electricity* (Franklinization) has been used for amenorrhœa, and with varying results. The very successful results of Dr. Golding Bird, in Guy's Hospital, have been indefinitely quoted, but have not been yet repeated to an extent sufficient to show that this form of electricity is superior to galvanization or faradization in the treatment of this affection. Others, however, as Holsbeck, Bitterlin, Taylor, Hervey, and Graves, have reported cures by this method.\*

*Prognosis in the Symptoms of Amenorrhœa, etc.*—Whatever method is used, *time* is required to insure results. While it is true that a single application, especially internal, may bring on the menses,—may even cause the blood to appear during the sitting,—yet in the majority of instances treatment must be more or less protracted in order to insure permanent relief. The very general impression that the object of electrization of the functionally diseased uterus is merely to *stimulate* the organ to its duty, is a great mistake. Electrization cures these diseases as much by its permanently tonic effects on the system, as by its temporarily stimulating effects on the organs themselves.

In nervous dysmenorrhœa the prognosis is more uniformly good than in amenorrhœa. In amenorrhœa the results, though often brilliant, are quite capricious, some cases yielding at once, others only after long treatment, and others not at all. In these remarks on prognosis it is assumed that no severe pathological state is the cause of the symptoms.

*Amenorrhœa associated with Anæmia—Recovery under general faradisation.*

CASE CXVIII.—Miss —, aged 20, was suffering from a condition of excessive debility and anæmia. She was hysterical to the last degree, and it was with the greatest difficulty that she could be persuaded to submit to electrization. These symptoms had annoyed her for about six months, during which time the menstrual flow had decreased in quantity and had become irregular until, some two months

\* Meyer, op. cit., p. 451.

before we saw her, it had altogether ceased. She was at once submitted to general faradization, and, although an exceedingly mild current was used, excessive faintness was produced, which lasted nearly twenty minutes. Subsequent applications were borne much more kindly, although the strength of the current was decidedly increased. Her menses returned after the eighth application, and during the treatment, which was continued for six weeks, the color returned to her cheeks, her step became firm and strong, her hysterical condition was entirely corrected, and at the very least it may be said that she was approximately restored to her usual health.

*Amenorrhœa of four years' standing, associated with slight anasarca and marked obesity—Menses restored and other symptoms relieved by general and localised external faradisation.*

CASE CXIX.—Miss H., 25 years old, was directed to us by Dr. T. Cock, of New York.

For four years the patient had menstruated sometimes three times, sometimes but twice a year. She had increased enormously in size, her weight being 180 pounds, and there was some effusion of the legs and feet, as manifested by the indentations remaining after pressure with the finger. The patient was very plethoric, and suffered much from fulness and oppression about the head. It is proper to remark that Dr. Cock, before submitting the case to electrization at our hands, had for some time faithfully made use of the internal remedies that seemed most suited to it. The patient was annoyed by cold feet and hands and by sudden flushes of heat. As in our experience general faradization has been more successful in equalizing the circulation than any other form of electrization, we determined to employ this method. In this as in the former case, extreme susceptibility to the current was manifested, but depending more on an excited mental condition than on any real sensitiveness of the nervous system.

The patient was under treatment from March 20, 1871, to May 25, 1871, and received twenty applications. A part of the time external localized faradization was employed. After the fifth séance the courses appeared and lasted two days. At the proper time during the course of treatment they reappeared and lasted some four days. The patient presented herself a few months after the cessation of the séances, and reported that not only the menstrual function continued to act regularly, but that she remained permanently better in every respect. The tendency to flushes of heat disappeared after the first menstruation, her extremities became warmer, and after the second menstruation she was entirely relieved of the watery effusion in the legs and feet.

An interesting but not altogether unusual result of the treatment was a marked decrease in flesh. During the administration of the first ten applications she lost some twenty pounds, and after the séances were discontinued she submitted to the Banting system, and was rewarded by a still further decrease in weight.

*Amenorrhœa of a year's standing, associated with vertigo and debility—Recovery under general faradization.*

CASE CXX.—Miss E. S., a school-girl aged 18, was suffering from suppression that had existed a year. The resulting symptoms were periodical attacks of distressing vertigo, and a condition of nervous exhaustion that unfitted her for the slightest mental or phys-

ical exertion. The faradic current was alone used, and, as in the two preceding cases, the applications were partly general. The menses reappeared after the twelfth séance, resulting in approximate relief of the vertigo and a decided increase of nervous strength. At the present time, two years since the function was restored, she continues regular.

*Amenorrhœa associated with hysteria—Spasmodic contractions of the muscles controlling deglutition—Recovery follows two applications of internal faradization after failure of general faradization.*

CASE CXXI.—Mrs. H., aged 35, a patient of Dr. C. P. Tucker, of New York, had for several years suffered excessively from a form of nervous prostration, partly hysterical in character, and which seemed in a measure to depend on an almost complete deafness which occurred suddenly after a season of excitement while she was yet an invalid from confinement. General faradization had, during the early part of 1870, very materially lessened these symptoms, and she had remained permanently better. In March, 1871, her menses ceased, resulting in a return, although in a less degree, of her old nervous symptoms. In October she began to be afflicted with vertigo and spasmodic contractions of the muscles controlling deglutition, which latter symptom progressively increased in severity until at times the patient could with difficulty take sufficient nourishment to satisfy hunger. We employed general faradization on two or three occasions, but, becoming satisfied that it was impossible to obtain any immediate result by this method, we resorted to internal faradization, using a cup-shaped metallic electrode, and thus localized around the os a powerful current of negative electricity. On the following day we repeated the operation, and in a few hours after the patient was rewarded by a flow somewhat scanty, and of a darker color than normal. It was attended also by considerable pain in the uterus and excessive itching all along the course of the vagina. The distressing spasmodic symptoms about the throat ceased immediately and completely, and have not yet shown any evidence of returning. General applications were continued every other day for a month, markedly relieving her nervous condition. At the next menstruation the flow was quite normal, and to the present date the patient continues regular.

*Amenorrhœa existing two and a half years—A copious flow follows twelve internal applications of the faradic current.*

CASE CXXII.—Miss E., aged 23, suffered from cold hands and feet, and a feeling of great fulness about the head, with vertigo, which symptoms depended, doubtless, on long-continued absence of the menses.

Aside from the above-mentioned symptoms, her general health and strength were unimpaired. As general electrization and galvanization localized externally gave no evidence of being of service, with the consent, and in accordance with the desire, of both the patient and her mother, we applied the current directly to the os by means of an exceedingly small ball-shaped electrode. Four such applications repeated at intervals of three days resulted in a copious flow, lasting forty eight hours. Greatly to my surprise, the associated symptoms were not relieved to any very great extent, and as the patient ceased her visits before the time for the second return of the catamenia, we were unfortunately not able to judge concerning the ultimate effects of the treatment.



*Amenorrhœa existing five months—Recovery under peripheral galvanization (external) after failure of faradisation.*

CASE CXXIII.—Mrs. S., a widow, aged 30. The patient suddenly ceased menstruating five months previously, and, accompanying the cessation, there was an annoying sense of fulness about the head with vertigo. When she applied for treatment, she stated that these abnormal symptoms had continued without abatement, and had rather increased in severity. A number of internal applications of the faradic current having been given without appreciable result, we localized as nearly as possible a galvanic current from twelve small-sized zinc-carbon cells through both ovaries and the uterus itself.

The catamenia returned twelve hours after the second application, which was given the day following the first. Just before the next menstrual period, the application was repeated, and was followed by the usual flow. The menses appeared the third time, preceded by no application of electricity. As to further results, we are uninformed.

*Amenorrhœa by intervals for several years—Relief of suppression by intra-uterine faradization with a powerful current after failure of external applications to the os by the uterine electrode.*

CASE CXXIV.—Miss S., aged 23, was sent to us by Dr. Fordyce Barker, July 6, 1870. During all her menstrual life she had been more or less irregular.

At various times she had been relieved by faradization of some kind, and had found by experience that it was necessary to use internal applications. Her general condition was not of the best, and suppression always brought general nervous derangement. We treated her at first by the uterine electrode (connected with the negative pole) against the os, and the positive either on the abdomen or lumbar region.

This treatment, repeated four times, brought on some appearance of blood, but not the free menstrual flow. One application, with the same strength of current, with the intra-uterine electrode for about the same time (ten minutes), brought on a profuse flow on the day following.

In regard to the foregoing cases, it is not to be understood that we present them as in any way typical of the results to be expected in every instance, even under the most judicious and correct methods of electrical treatment. The failures are sufficiently frequent, as every one who has had much experience in this direction will readily testify.

From among many unpublished cases, we desire to transcribe the following for the reason that it presents points of interest that are seldom found.

*A remarkable case of membranous dysmenorrhœa—Interesting results of electrization.*

CASE CXXV.—Mrs. —, aged 30, was sent to us for electrical treatment by Drs. John T. Metcalfe and T. G. Thomas. The patient was large and well nourished and presented every appearance of one in vigorous health; yet there had been in the past a very considerable derangement of her nervous equilibrium. There was

usually only slight pain preceding the onset of menstruation, increasing a little as it made its appearance. In about forty-eight hours the distress became very great, and continued without abatement for several days up to the cessation of the catamenia. Careful examination by Dr. Thomas revealed no mechanical constriction, and it was suggested that the probable cause was a tonic spasmodic contraction of the os uteri, resulting from reflex irritability. This condition of affairs had been almost constant for seven years, notwithstanding varied methods of treatment, and the propriety of incising the cervix had been seriously considered.

We will briefly describe the method of treatment substantially followed out, and then refer to the results.

We alternate the use of the faradic and galvanic currents, administering four applications a week. External treatment was alone employed, because of the disinclination of the patient to submit to internal applications. The faradic current was used by the method of general faradization—each seance being ended by a purely local application.

In using the galvanic current, the first half of a seance of eight minutes was devoted to galvanization of the whole length of the spine by the labile method, the operation being concluded by a local stabile application. Beginning at each seance with a current from ten ordinary zinc-carbon elements the number was gradually increased to twenty-four, and then as gradually decreased. Treatment was begun on May 23, 1878. On June 3d the menses appeared, and, although by no means painless, far less distress was experienced than usual. The courses ceasing, treatment was continued up to June 29th. Their second appearance was attended by absolutely no pain worthy of mention.

The patient now left the city for the season, and in due course the menses appeared for the third time since the beginning of treatment, and unattended with any sense of discomfort. Attending their fourth appearance, however, there was very decided pain, and on September 11th, on her return from the country, the electricity was resumed. After a few applications of the galvanic current, pains, supposed to be premonitory of menstruation, were felt, and so increased that Dr. Metcalfe was called in, and found that the patient was suffering from a miscarriage.

Having recovered from this mishap, electricity was again attempted, and has been followed by a gradual improvement to the present time of writing. Since the expulsion of the embryo there has been more or less discharge of membrane at each period. This has somewhat complicated the case, and although it is still under observation, a complete recovery seems assured.

Connected with this case two important and interesting questions arise :

1st. Was the electrical treatment in any way efficacious in rendering conception possible? When it is considered that in seven years pregnancy had not occurred, while conception took place soon after the galvanic treatment—which had been so effective in relieving the pain and its probable causation, viz., spasmodic contraction of the os uteri—it is not difficult to believe that its agency was very great.

The second question relates to the possibility of this miscarriage being in any way due to the treatment. In the first place, it is well

known to every electro-therapeutist (although the contrary opinion is quite prevalent) that it is exceedingly difficult, and, *as a rule*, impossible, to cause an abortion by any ordinary external application of electricity—external or internal. In this statement, intra-uterine applications are, of course, not included, nor those susceptible cases with a tendency to abort upon the reception of any strong or sudden impression of mind or body. We have treated women in all stages of pregnancy for various nervous difficulties, and have never yet seen harm result. To produce any mechanical or reflex effects sufficient to detach the fœtal connection, necessitates a degree of current strength not ordinarily required in therapeutics. Again, the severe illness of a near relative had taxed our patient to an extent sufficient in itself to account for a result that would have been gladly avoided.

*A case of dysmenorrhœa due to spasm of os uteri—Recovery.*

CASE CXXXVI.—Mrs. D—, aged 33, the mother of three children, consulted us December 23, 1878, for excessive dysmenorrhœa, from which she had suffered for over five years. At the same time, the flow was very much greater than normal, resulting in constant anæmia, and an exhausted condition, from which she barely recovered before a recurrence of the menses. The patient had, for years, been the victim of uterine displacement, which she had failed to have permanently rectified, and to it she attributed her sufferings. Upon examination, we found a simple ante-flexion, associated with a very great degree of tenderness of the vaginal walls, and especially of the os itself. So tender were these parts during the week preceding menstruation, that very slight internal pressure caused intolerable pain. The acute distress from which she periodically suffered, usually began about thirty-six hours before the appearance of the menses, reaching its height as the flow became manifest. From this time, the pain gradually decreased in severity, and during the last two days of sickness was very slight.

Having in mind the previous case, where the dysmenorrhœa was supposed to be due to spasmodic contraction of the cervix, we were led to make a digital examination about twenty-four hours before menstruation, and while the patient was suffering pain of the most distressing character. On touching the os tinæ with the index finger, and sweeping it around on every side, the constriction and relaxation of muscular fibres were distinctly appreciable, being evidenced by the alternating hard and soft feel of the uterine neck. Hoping that some immediate relief might be afforded, we attempted the following treatment :

Placing the patient on her back, we introduced several small sponges, somewhat after the manner suggested to us in another case by Dr. T. G. Thomas. The sponges, as fine and soft as possible, were carefully packed around the cervix, pressing up against the body of the uterus, and completely covering the os. Against these was gently, but firmly, pressed a flat metallic electrode, covered with wet chamois skin, and this again was connected with the anode. Connected with the cathode, was an ordinary sponge electrode, which was firmly held on the abdomen above the pubes. Intercalating a rheostat, and beginning with the least possible current strength, it

was gradually increased, until a slight pricking sensation was felt under the external electrode. The action of the anode, on the contrary, was accompanied by no pain, but its effects were evident; for, from the moment the circuit was made the rest from pain, which had before been excessive and constant, was complete. After an application of ten minutes, the current strength was gradually decreased to its minimum, and discontinued. The remission of pain continued for ten hours, when some distress was again experienced, which increased, and on the appearance of the flow became quite severe. At the cessation of the menses, general faradization was alternated with external applications of the galvanic current to the spinal cord and abdomen. As the next period approached, pain began, as usual, about thirty-six hours before hand, and although much less severe, there was not, as before, anything like a complete remission. The amount of blood lost was, however, decidedly less.

During the second month the external application of both currents was continued, and on each of the three days preceding menstruation, internal applications were given according to the method first attempted. The flow was established and continued throughout without the slightest suspicion of pain.

During the past month the patient has not been subjected to any treatment, and at this date (March 24th) she has just completed her fourth menstruation since we first saw her. Not only has it been entirely painless, but the flow was also normal.

*Menorrhagia of four years' duration due to fungoid degeneration—Rapid recovery under intra-uterine applications.*

CASE CXXVII.—Mrs. B., aged 46, consulted us in consequence of severe hemorrhage to which she was periodically subjected. Five years prior she observed some slight increase in the menstrual flow. It became increasingly abundant until in the course of a year the loss of blood at each menstrual epoch was frightful. For the first day or two only was the flow thus alarmingly copious, but its immediate effects were to render her completely colorless and almost pulseless. The flow would now rapidly become less, but for two or three weeks there was a very slight although constant discharge of bright arterial blood. The courses did not appear with normal regularity, an interval of six weeks to two months ordinarily occurring. It is quite evident that if menstruation had occurred every four weeks the patient could hardly have survived for so long a time her repeated depletions; and, as it was, she was just enabled, by the aid of a good appetite and vigorous digestion, to regain a measure of strength and color before the recurrence of her trouble. We began treatment in the decline of one of these hemorrhages, and for the relief of the persistent insomnia resulting from her anæmic condition and the pain in her legs, general faradization was administered on alternate days. It aided very greatly in inducing sleep and relieving pain, and markedly hastened returning strength.

Shortly after these tentative applications were begun, we met at the house of the patient Dr. W. G. Alling, of New Haven, Conn., under whose care she had been a short time before, and from whom she had received continued and judicious treatment, both constitutional and local, but without decided relief. Dr. Alling's examinations had found the uterus to be three and one-half inches in depth and slightly retroverted. When the probe was carried into the cavity at the first examination, slight hemorrhage followed its withdrawal, and a small fungoid mass came away. Further examination revealed considerable fungoid degeneration of the mucous membrane. We proposed alternating the general treatment with intra-vaginal and mild intra-uterine ap-

plications. This method of procedure was repeated up to the day of menstruation—the patient in the meanwhile having regained, with far more than ordinary rapidity, her color and strength. The flow was considerably more profuse than normal, but could not be compared in severity with those that had previously occurred. In ten days the flow ceased, and treatment was continued until the return of the catamenia, when a still greater improvement was evident. For three months this treatment was kept up, when the patient left the city for the summer, with the feeling that her recovery was an assured, if not an accomplished fact. Four years have since elapsed, but there has never been a recurrence of these hemorrhages, and, moreover, the patient has been ever since, and is still, in the enjoyment of robust health.

That the pathological state on which the symptoms of uterine diseases depend have not been sufficiently considered is very evident from a study of the history of the electrotherapeutics of these diseases. There is need of accurate diagnosis, and especially of careful measurement, before, during, and after electrical treatment in order to know just how much it accomplishes. These measurements should be made by experts in gynæcology. The future will show that very much can be done for congestion, atrophy, and engorgement of the womb by careful localized electrization.

*Atrophy of the uterus—Scanty menstruation—Sterility—Increase in the size of the organ and in the amount of the menstrual flow under internal faradization and central galvanization and general faradization.*

CASE CXXVIII.—Mrs. P., a young married lady, was referred to us January 17, 1872, by Dr. Fordyce Barker, for the symptom of sterility. According to Dr. Barker's diagnosis there was atrophy of the uterus, and he was in the hope that electrization might, by improving the nutrition of the uterus, perhaps remove the sterility. It was supposed also that there might be atrophy of all the generative organs, since the menstruation was defective, though regular, and the patient was withal quite anæmic. We treated the patient for six weeks by internal faradization of the uterus, with our intra-uterine electrode, through the speculum; external faradization over the back, and the region of the ovaries; general faradization and central galvanization occasionally. The patient came every other day. Internally she took iron and strychnine.

At the first menses after treatment the patient remarked an increase of quantity, and the courses were on her one day longer than usual. By the 1st of March, after six weeks' treatment, Dr. Barker found on examination that the uterus had increased in length one-quarter of an inch. The patient after an interval was again treated, but without any local improvement.

The modification of nutrition caused by electricity may have two opposite effects; it may cause increase or it may cause diminution in the size of a part or organ. Where the part is abnormally large it causes it to grow smaller; where it is abnormally small or atrophied, as in the above case, it causes it to grow larger. In these opposite results there

is nothing inconsistent ; they are readily explained by the change in nutrition caused by the current.

*Congestion, Enlargements, Displacements, and Atrophy of the Uterus.*—Tripier, Beauvain, Seiler, Fano, Beau, and ourselves have treated engorgements and flexions, prolapsus and atrophy of the uterus by electricity. Both the galvanic and faradic currents are employed.

The occasional results obtained in prolapsus uteri are to be explained partly by the chemical and mechanical effects of the current on the structure of the uterus, and partly by its tonic effects on the ligaments and vaginal walls.

*Treatment.*—In the treatment of the various displacements of the uterus, the application must, of course, be varied with the morbid condition. Special rules cannot be given in any detail ; each case must be studied by itself.

According to Tripier,\* *chronic metritis* and enlargement of the uterus, is best treated by applying the uterine electrode against the os, and connecting the other pole (bifurcated) with an insulated rectal electrode in the rectum and a sponge electrode over the abdomen.

*Prolapsus uteri* the same author treats by applying the uterine electrode against the os and connecting the other pole (bifurcated) with two sponge electrodes, one on each groin.

For *anteversion and ante flexion* he introduces the negative pole into the rectum, where it can act more powerfully on the posterior part of the uterus, and the positive in the vagina.

For *retroversion and retro flexion* he applies the positive pole in the bladder or over the abdomen, while the negative is applied to the os, by the uterine electrode, an air pessary having first been put into the rectum to elevate the fundus.

By properly insulating the electrode, the current—faradic or galvanic—can be localized in any restricted portion of the uterine canal.

The treatment may be regarded as an important adjuvant in all rebellious cases of engorgement and atrophy of the uterus or of its appendages, and of uterine displacement, and especially of those that are associated with general debility. The contracting influence of the electrical currents over involuntary muscle is a strong physiological argument in favor of the use of this remedy in uterine engorgement (see chapter on Involuntary Muscles in Electro-Physiology).

Tripier † details thirty cases of various phases and complications of uterine disease treated by localized faradization.

\* Loc. cit., p. 38 et seq.

† Annales de l'Electro-Thérapie, p. 202 et seq. 1863.

Of *anteflexion and anteversion*, four cases recovered, two were improved, and in one case no result was obtained.

Of *retroversion and retroflexion*, one case recovered, one was improved, and in one case there was no result.

Of *engorgement*, two cases recovered.

Tripier further *observed very marked effects on the general system, and severe symptoms of hysteria, neuralgia, and nervousness were greatly ameliorated.* If general faradization and central galvanization had been employed, these constitutional effects would have been much more marked.

*Prolapsus uteri—Leucorrhœa and menorrhagia—Loss of tone in vaginal walls—Recovery under faradization of uterus and general faradization.*

CASE CXXIX.—Miss T., an unmarried lady, aged 30, applied for treatment for falling of the womb of the second degree, from which she has suffered for nearly six months. Previous to the first symptoms of prolapsus, persistent leucorrhœa had annoyed her for some time, and had continued up to the day she came to us. She complained also of some menorrhagia. These conditions, however, were evidently associated with no organic uterine disease; but her general health was quite feeble. If it were a case for electricity at all, it was plain that she needed its tonic influence. We commenced, therefore, with mild general applications, increasing the strength of the current at each visit as she was able to bear. At each sitting, also, the electrode was applied for a few minutes against the os and the vagina. The beneficial results of this course of treatment were soon observable. Her appetite, which had been capricious, became more rational, and her strength increased with marked rapidity. The vaginal walls seemed to gain tone day by day, until after the sixth application the uterus was restored to its normal position.

*Irritation and Congestion of the Ovaries.*—Irritation and neuralgia of the ovaries accompanying hysteria are treated electrically with advantage. Congestion of the ovaries is also similarly treated with excellent result—at least for the relief of the symptoms.

*Intra-Uterine Galvanic Pessaries.*—The attention of the profession was called to the use of galvanic intra-uterine pessaries by Sir J. Y. Simpson. The instrument which he employed was composed of a piece of zinc and a piece of copper fastened together into a shape and size suitable for entrance into the uterine cavity.

As thus constructed the instrument was stiff and unyielding, and was not adapted for the various states of uterine flexion. This form of pessary Prof. T. G. Thomas\* has greatly modified by substituting for the single pieces alternate beads of zinc and copper, which are arranged

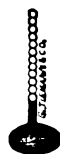

FIG. 115.  
Intra-Uterine Galvanic Pessary.

\* A Practical Treatise on the Diseases of Women. Second edition, p. 500.

on flexible wire inserted in a rubber bulb (Fig. 115). This instrument we will still further improve by *insulating* the wire on which the beads of zinc and copper are strung, except at the extremities, where it makes metallic connection at one end with the zinc, and at the other with the copper bead, thus forming a miniature voltaic pile, with a completed circuit.

When this contrivance is closely embraced by the lining membrane of the uterus, and thoroughly moistened by the uterine fluids, a feeble current is unquestionably generated.

When, therefore, such a galvanic pessary is *in situ* it is probable that the very feeble current, as it passes through the metallic beads, may traverse, to a limited extent, the folds of the lining membrane of the uterus, which presses between them.

The question whether the very slight current thus produced, combined with the necessary mechanical effect of the metals in such case, is capable of important therapeutic results, can only be answered by extended experience and discriminating observation.\*

Dr. Thomas assures us that in amenorrhœa positive therapeutical results have been obtained by the use of this pessary ; but is unable to say whether the results are due to the mechanical effect of the metals or to the action of the current.

Dr. Peaslee also has seen favorable results from the use of the same pessary.

The question whether the therapeutical effects are due to the pressure of the foreign body or to the action of the current might be settled by substituting glass beads for the metals.

Dr. Murray, quoted by Althaus,† has used Simpson's intra-uterine galvanic pessary with success in cases of sub-involution of the uterus, where the os is open, the lips thickened, and the whole organ flabby with excess of menstruation and disagreeable discharge. In one marked case a fortnight's use of this instrument reduced a flabby uterus "nearly to its normal and healthy condition."

An important practical difficulty in using these pessaries is that they will not always remain in position. To meet this difficulty springs have been attached to the handle which fall against the walls of the vagina, and thus keep the pessary from slipping out.

\* The white coagula that are observed after this application of this pessary are caused by the chemical action of the current on the intra-uterine fluids.

† Op. cit., p. 631.



## CHAPTER XXVIII.

### DISEASES OF CHILDREN.

**THE** diseases of children in which electricity has been found of service are the following:—

Chorea,	Marasmus and General Debility,
Whooping-Cough,	Incontinence of Urine,
Cholera Infantum,	Vomiting,
Laryngismus Stridulus,*	Infantile Paralysis.

*Treatment.*—Chorea has been successfully treated by a variety of methods of electrization—by frictional electricity, peripheral faradization,† and galvanization of the spine,‡ and in our hands general faradization and central galvanization. Successful results have been gained by all these methods. We have found general faradization and central galvanization alone so successful in cases of general chorea, that we have but rarely had occasion to experiment with other methods.

Our success with general faradization in chorea is probably to be accounted for partly by the muscular exercise that is derived from this method of treatment, as well as by the tonic action of the current on the nervous system. Choreic patients do not usually bear strong central galvanization or protracted sittings; the milder influence of the faradic current is preferable to the galvanic, unless the latter is used with considerable caution. Benedikt claims to have been uniformly successful in more than twenty cases of chorea by galvanization of the spine. He used, however, but a small number of elements, and the length of the sittings was not more than one and a half minutes. Other observers have not been so successful with this method. Meyer reports unsatisfactory results with galvanization of the spine in two or three cases. § It is probable that the success of Benedikt with galvanization of the spine was due to the very great caution which he exercised in regard to the strength of the current and the length of the sittings, as

\* This affection is considered under Diseases of the Larynx.

† Duchenne and Becquerel.

‡ Benedikt.

§ Op. cit., p. 364.

he himself declares that the symptoms were aggravated if the number of elements were much increased. For hemi-chorea Benedikt recommends galvanization of the head. We prefer for all cases of chorea general faradization, occasionally varied by central galvanization, with very mild currents, and believe that this method of treatment faithfully used will do all that can be done for this disease through electricity.

*Prognosis.*—In regard to the prognosis of chorea under electrical treatment there has been considerable skepticism, even among those who are friendly to electro-therapeutics. This skepticism has been due to the fact that the majority of cases of chorea recover spontaneously in time, and because their improvement under electricity is, in some cases, quite slow.

Aside from the well-known fact that many cases recover spontaneously in the course of a few weeks or months, direct and positive results of treatment can be appreciated in this disease more uniformly than in any other spastic condition. Cases of failure after protracted treatment by electricity are exceptional. The worst cases, when recent, sometimes seem to yield better than those which are comparatively mild.

Partial chorea, affecting the eyelid, the muscles of the neck, or a single limb, or group of muscles, is more obstinate than a much worse form of general chorea. The explanation of this inconsistency is that patients affected with partial chorea are apt to delay weeks, months, and years before taking treatment. Recent cases we have found to yield almost uniformly. All long-standing choreic cases need to be treated perseveringly—from one to several months being usually necessary to complete a cure. In some cases no apparent improvement takes place at the outset of electrical treatment, and the friends of the patient become discouraged; but if the treatment be continued, a permanent cure may be obtained. Symptomatic chorea—dependent on cerebral or cerebellar disease—offers an unfavorable prognosis.

*General chorea, with inability of the patient to walk, feed himself, or distinctly speak—Recovery under central galvanization, after the failure of general faradization and medication.*

CASE CXXX.—Master S., a little boy about ten years old, came to us through Dr. J. O. Farrington.

The patient had for some time suffered from general chorea of a decided character, but during the last few weeks it had so increased in severity that he was unable to walk, or even feed himself. All his extremities as well as the face were in constant motion; his utterance was indistinct, and in weight he had decreased very much. There was no hereditary tendency of this character in the family, and the only cause to which the symptoms could plausibly be attributed was a fall from a horse, which severely jarred him, some weeks before the disease manifested itself.

The treatment was varied. Fowler's solution and certain other remedies, which we do not now recall, had been faithfully tried, but without benefit. We began with mild general faradization, but, as the results did not accord with our expectations, we abandoned it and essayed very gentle central galvanization.

During the first week of this treatment no appreciable benefit seemed to be derived, except an improvement in sleep.

Soon after this, however, the effect observed was decided. His appetite became better, resulting naturally in increased weight; co-ordination of movement rapidly became possible, the utterance distinct, and in a few weeks recovery was complete.

Treatment was discontinued in February, 1871, and to this date there has been no evidence of a return of the disease.

*Chorea of ten months' standing, of the left side and right arm, in a girl of eleven—  
Recovery in ten weeks under central galvanization.*

CASE CXXXI.—M. R., a little girl, aged eleven, was directed to us by Dr. H. H. Gregory, of Harlem. Some ten months before, the mother first observed slight convulsive twitchings of the left hand, which gradually increased in severity until in a few weeks the member was quite useless. In two or three months the left leg became choreic, and soon after the disorder extended to the right arm. It was one of those cases which obstinately resist ordinary internal medication, and was hence considered a fair opportunity to test the virtues of central galvanization. The treatment was given every other day, but for three weeks no apparent impression was made upon the disease.

During the fourth week the symptoms somewhat abated, and from this time forth the improvement was uninterrupted, until, in ten weeks from the beginning of the treatment, recovery was perfect.

*Choreic disturbance of the head of five months' duration—Recovery under less than twelve applications of general faradization.*

CASE CXXXII.—Minnie V., aged 8 years, had been affected for five months with severe and almost constant nervous twitchings of the head. They were evidently choreic in character, occurred without the consciousness of the child, and during sleep were entirely wanting. The patient was somewhat depressed in health and decidedly anæmic, and we therefore submitted her to general faradization. Under the influence of less than a dozen applications she gained in appetite and strength. The choreic disturbance became decidedly less marked, and after the cessation of the treatment, for the purpose of allowing the secondary effects to be manifested, it was not more than ten days before recovery was complete.

*Chorea of a year's duration—Improvement during treatment, and rapid recovery after its cessation.*

CASE CXXXIII.—A little boy of a delicate organization was sent to us by Dr. Geo. Peters. The child had been affected with general choreic movements of a decided though not severe character for a little more than a year. The mechanical effects of the faradic current seeming to disagree with the patient, we submitted him to mild séances of central galvanization. Some fifteen applications were administered during the month which resulted in some improvement. At this stage the treatment was necessarily interrupted, but the improvement continued, and in a few weeks the recovery was quite complete.

In not a few cases of chorea the beneficial effects of electrical treatment became manifest—as in the above—after cessation of the applications.

*Severe chorea in a girl seven years of age—Less than usual sensitiveness on the head—Recovery under ten general faradisations.*

CASE CXXXIV.—L. J., a girl seven years of age, was brought for treatment by general electrization in September, 1868. She was pale and slender, but quite tall for her age. For eighteen months her growth had been remarkably rapid, and to this fact the mother was inclined to attribute the disease. The parents first noticed some twitching of the left-hand in the fall of 1866, but did not at the time give it particular attention. The choreic symptoms rapidly increased to such an extent, however, that they became alarmed, and applied for medical treatment. But in spite of persistent internal medication, the want of power to co-ordinate her movements grew more marked, and the symptoms extended to her limbs and organs of speech. At the time that the patient came under our notice the choreic movements were quite violent. The left side was considerably more affected than the right, and her articulation was so indistinct that it was impossible for a stranger to understand what she said. We found no difficulty in inducing the child to submit to the treatment, but the involuntary agitation of the legs was so great that it was found necessary to hold the feet upon the plate to which the negative pole was attached.

The current was very sensitively felt over the stomach, but not over any other portion of the body. It may be remarked, however, that over the head could be borne without discomfort a current much more intense than is the case in the normal condition.

The first and second applications resulted in no appreciable change in her symptoms; but at the fourth visit, about ten days after the first, a perceptible improvement was noticed. As is usually the case when a favorable result follows any method of treatment, the diminution of the choreic movement was *first manifested in the lower limbs*. The progress towards recovery was very rapid.

At the fifth visit she could retain her feet upon the plate by her own unaided efforts, while the application was being made. This improvement had also extended to the arms and face, and the tenth application, administered about a month after the first, dissipated every choreic symptom. There was one peculiar and well-marked feature, which we observed in this as well as in several other cases. We refer to the intensity of the current used when applications were made to the head. As the disease advanced toward recovery, such applications became more and more painful, so that it was necessary to gradually decrease their power.

*Chorea of face and arms in a lad twelve years of age, dependent on mental influences—Recovery under localized faradization.*

CASE CXXXV.—In December, 1866, a lady brought to us a little boy, aged 12 years, to be treated for symptoms that were somewhat anomalous, yet not of a character sufficiently marked to enable us to say positively that St. Vitus's dance proper existed. While in perfect repose, and even when engaged in play, study, or conversation, if there was nothing to excite or alarm, he exhibited nothing unusual in his movements. If, however, he failed in his recitations, was scolded by his parents, or if he became

excited in his play, or was abashed by the notice of a stranger, some peculiar symptoms became immediately manifest. The muscles of the face became convulsed, and at times the twitching was quite violent, so that his appearance was grotesque in the extreme. Rapid contractions of the muscles of the arm also occurred. These were most noticeable in the biceps and flexors of the hands and fingers.

The child was to all appearance perfectly healthy, and was of a lively and genial disposition.

This disorder of the nervous function had existed some four or five months, so that considerable uneasiness was excited in the minds of the friends of the patient. As he lived a considerable distance from the city, applications were given only occasionally, as his attendant found it convenient to bring him. During the course of a month the boy visited us some five or six times, and as he was suffering from no debility, we judged it to be sufficient to make the applications only to the parts affected, and not to extend them over the whole surface of the body. The result of this irregular treatment was successful, since all the abnormal movements to which he had been so readily liable on exposure to any excitement became less and less marked. At the end of the month he left us cured.

*An aggravated case of chorea resists the action of the galvanic, but yields to general electrization with the faradic current—Relapses, and again recovers under the same treatment.*

CASE CXXXVI.—A little patient, aged 10 years, under the professional care of Dr. J. O. Farrington, presented the severest symptoms of chorea.

Prof. George T. Elliott was called in consultation May 18, 1868, and by these gentlemen electrical treatment was advised.

Some two months previous to the consultation certain abnormal movements—such as starting suddenly to his feet, throwing out a hand or a foot, etc.—were observed by the teacher of the boy. Two weeks subsequently, the patient was seized with well-marked choreic symptoms of the right side of the body, and in two days the disturbance extended to the opposite side. So constant and violent were the movements of his arms and legs that it was impossible to keep him on a bed or sofa. It was necessary to place him on the carpet, surrounded by inflated rubber bags. Intelligence seemed to be perfect, but the power of speech was lost and the sufferer made known his wants by impatient cries and ill-directed motions.

Sleep was impossible without the nightly administration of an opiate. Contrary to our judgment, but by suggestion, we commenced treatment by the use of a mild galvanic current directed especially to the base of the brain and the spinal tract; but this method served only to aggravate the child's condition. We then resorted to the faradic current by the method of general electrization, but so violent were the involuntary movements in the limbs and body of the patient, that it was with difficulty that he could be held in a sitting posture and his feet kept on the copper plate to which the negative pole was attached. The applications were *general*—every portion of the body, from the head to the feet, being influenced on each occasion.

Improvement was manifest from the very first. He was at once enabled to sleep soundly, although his opiate was reduced one-third, and after the fourth application it was dispensed with altogether. In the course of three weeks, during which time fifteen applications were given, the case was so far improved that the patient was able

In not a few cases of chorea the beneficial effects of electrical treatment became manifest—as in the above—after cessation of the applications.

*Severe chorea in a girl seven years of age—Less than usual sensitiveness on the head—Recovery under ten general faradisations.*

CASE CXXXIV.—L. J., a girl seven years of age, was brought for treatment by general electrization in September, 1868. She was pale and slender, but quite tall for her age. For eighteen months her growth had been remarkably rapid, and to this fact the mother was inclined to attribute the disease. The parents first noticed some twitching of the left hand in the fall of 1866, but did not at the time give it particular attention. The choreic symptoms rapidly increased to such an extent, however, that they became alarmed, and applied for medical treatment. But in spite of persistent internal medication, the want of power to co-ordinate her movements grew more marked, and the symptoms extended to her limbs and organs of speech. At the time that the patient came under our notice the choreic movements were quite violent. The left side was considerably more affected than the right, and her articulation was so indistinct that it was impossible for a stranger to understand what she said. We found no difficulty in inducing the child to submit to the treatment, but the involuntary agitation of the legs was so great that it was found necessary to hold the feet upon the plate to which the negative pole was attached.

The current was very sensitively felt over the stomach, but not over any other portion of the body. It may be remarked, however, that over the head could be borne without discomfort a current much more intense than is the case in the normal condition.

The first and second applications resulted in no appreciable change in her symptoms; but at the fourth visit, about ten days after the first, a perceptible improvement was noticed. As is usually the case when a favorable result follows any method of treatment, the diminution of the choreic movement was *first manifested in the lower limbs*. The progress towards recovery was very rapid.

At the fifth visit she could retain her feet upon the plate by her own unaided efforts, while the application was being made. This improvement had also extended to the arms and face, and the tenth application, administered about a month after the first, dissipated every choreic symptom. There was one peculiar and well-marked feature, which we observed in this as well as in several other cases. We refer to the intensity of the current used when applications were made to the head. As the disease advanced toward recovery, such applications became more and more painful, so that it was necessary to gradually decrease their power.

*Chorea of face and arms in a lad twelve years of age, dependent on mental influences—Recovery under localized faradization.*

CASE CXXXV.—In December, 1866, a lady brought to us a little boy, aged 12 years, to be treated for symptoms that were somewhat anomalous, yet not of a character sufficiently marked to enable us to say positively that St. Vitus's dance proper existed. While in perfect repose, and even when engaged in play, study, or conversation, if there was nothing to excite or alarm, he exhibited nothing unusual in his movements. If, however, he failed in his recitations, was scolded by his parents, or if he became

excited in his play, or was abashed by the notice of a stranger, some peculiar symptoms became immediately manifest. The muscles of the face became convulsed, and at times the twitching was quite violent, so that his appearance was grotesque in the extreme. Rapid contractions of the muscles of the arm also occurred. These were most noticeable in the biceps and flexors of the hands and fingers.

The child was to all appearance perfectly healthy, and was of a lively and genial disposition.

This disorder of the nervous function had existed some four or five months, so that considerable uneasiness was excited in the minds of the friends of the patient. As he lived a considerable distance from the city, applications were given only occasionally, as his attendant found it convenient to bring him. During the course of a month the boy visited us some five or six times, and as he was suffering from no debility, we judged it to be sufficient to make the applications only to the parts affected, and not to extend them over the whole surface of the body. The result of this irregular treatment was successful, since all the abnormal movements to which he had been so readily liable on exposure to any excitement became less and less marked. At the end of the month he left us cured.

*An aggravated case of chorea resists the action of the galvanic, but yields to general electrization with the faradic current—Relapses, and again recovers under the same treatment.*

CASE CXXXVI.—A little patient, aged 10 years, under the professional care of Dr. J. O. Farrington, presented the severest symptoms of chorea.

Prof. George T. Elliott was called in consultation May 18, 1868, and by these gentlemen electrical treatment was advised.

Some two months previous to the consultation certain abnormal movements—such as starting suddenly to his feet, throwing out a hand or a foot, etc.—were observed by the teacher of the boy. Two weeks subsequently, the patient was seized with well-marked choreic symptoms of the right side of the body, and in two days the disturbance extended to the opposite side. So constant and violent were the movements of his arms and legs that it was impossible to keep him on a bed or sofa. It was necessary to place him on the carpet, surrounded by inflated rubber bags. Intelligence seemed to be perfect, but the power of speech was lost and the sufferer made known his wants by impatient cries and ill-directed motions.

Sleep was impossible without the nightly administration of an opiate. Contrary to our judgment, but by suggestion, we commenced treatment by the use of a mild galvanic current directed especially to the base of the brain and the spinal tract; but this method served only to aggravate the child's condition. We then resorted to the faradic current by the method of general electrization, but so violent were the involuntary movements in the limbs and body of the patient, that it was with difficulty that he could be held in a sitting posture and his feet kept on the copper plate to which the negative pole was attached. The applications were *general*—every portion of the body, from the head to the feet, being influenced on each occasion.

Improvement was manifest from the very first. He was at once enabled to sleep soundly, although his opiate was reduced one-third, and after the fourth application it was dispensed with altogether. In the course of three weeks, during which time fifteen applications were given, the case was so far improved that the patient was able

to utter distinctly words and sentences. The choreic symptoms were so much diminished that the boy could readily sit quiet and alone, and during an application was able to command the movements of his body and feet. Improvement continued during the administration of a few more applications, when the child was taken to the sea-shore, where in two weeks he quite recovered. After having enjoyed excellent health for a year and a half, the boy suffered from a second attack. He was immediately subjected to the influence of electrization, and recovered even more rapidly than before.

*Marasmus and General Debility.*—In the treatment of marasmus and general debility of children, Dr. Beard has recently made a series of experiments at the Sheltering Arms Institution in Brooklyn, which is under the medical charge of Drs. Jerome Walker and Frank Rockwell. In addition to this hospital experience, Dr. Rockwell has, in private practice more especially, had very many opportunities of testing the efficacy of the various forms of electricity in the diseases under consideration. In these investigations a number of marasmic cases and of cases of debility of various kinds, some of a most serious character, were treated by general faradization, and with most pleasing results. The remarkable improvement in nutrition that the young of animals may derive from general faradization has already been described (see chapter on Nutrition, in *Electro-Physiology*).

Two important facts were brought out and confirmed in these experiments :—

1. That very young children—under one year—could bear as large doses of general faradization as adults.
2. That the recognized tonic effects of general faradization—improvement in sleep, appetite, and in rapidity and vigor of growth—are appreciated by infants even more rapidly than by adults.

Cases that were fast failing were restored, and in one or two instances life was apparently saved by the treatment.

*Marasmus in a child aged four—Recovery under general faradization after failure of the accepted methods of treatment.*

CASE CXXXVII.—F. C., a little boy aged 4, had been prostrated for some time with diarrheal symptoms with fever. These symptoms became modified under treatment ; but the child continued excessively weak, with no appetite, with paroxysms of feverishness, sleeplessness, profuse night-sweats, and *progressive emaciation*. No form of medication seemed of much service ; and as the condition of the patient had assumed a chronic character and clearly pointed to disease of the mesenteric glands, electricity was advised by both Drs. H. H. Gregory, the attending, and the late Geo. T. Elliot, the consulting physician.

We submitted the little patient to general faradization carefully but thoroughly applied. In one respect its effects were immediately and decidedly evidenced.



The sleep was bettered and the profuse perspiration very markedly checked. For six weeks this treatment was repeated every night, and while there was no rapid progress towards health, yet from the beginning of treatment the improvement was gradual and uninterrupted until the recovery was complete.

*Whooping-Cough.*—In the institution mentioned on the preceding page, and in private practice, sixteen cases of whooping-cough in various stages of the disease have been treated, mainly by central galvanization. The result was improvement in every case. The paroxysms were diminished in frequency and violence, and in some instances the length of the distressing stage of the disease was shortened.

In cases complicated with debility there was improvement in general nutrition. In one case where great debility, resulting from congenital syphilis existed, the improvement in general nutrition was most striking; and in that case general faradization was mainly used. In most of the cases treated, the usual medication in wide variety, including quinine, had been tried. All medication was stopped shortly after the electrical treatment was adopted.

*Incontinence of Urine.*—This very distressing infirmity will sometimes yield to local or central galvanization, but the good results that are obtained by these methods of treatment are not always permanent.

In conjunction, however, with other tonic remedies, it is undoubtedly a valuable aid in the treatment of this disease.

In cases where there is an almost absolute want of control over the bladder, the local application of the faradic current is strongly indicated, and will frequently alleviate the symptoms.

The following case is illustrative of the good effects that may occasionally follow the use of electricity:

*Incontinence of urine since birth in a child aged six—Recovery in six months under local faradization.*

CASE CXXXVIII.—Willie —, a little boy, aged six, had been annoyed, more or less, by this want of control over the bladder since his birth. He invariably wet his bed at night, and it was not unusual for him to meet with accidents by day. He was a fine healthy boy, and therefore he was submitted to simple localized faradization. The treatment was not kept up very regularly, but once or twice a week, as he happened to visit the office. In about a month, his mother observed a very decided improvement. The improvement slowly continued, and in the course of six months the patient seemed to have gained ordinary control over this function.

*Vomiting and Cholera Infantum.*—Both vomiting in children and cholera infantum are treated with advantage by bromide of potassium and by the tonic influence of sea, mountain, and country air. It would therefore be just to suppose that these affections might be successfully

treated by electricity. Dr. Lente, of Cold Spring, informs us that he has had excellent results in the treatment of vomiting in children by faradization. Dr. O'Reilley, of Louisville, Ky., reports good results from faradization in cholera infantum.

*Infantile Paralysis.*—Paralysis in infants, though often of a reflex character, is so frequently dependent on some morbid condition of the spine, that it might properly be included under *spinal paralysis*. Like paraplegia in adults, it depends on a variety of diseased states of the spinal cord and its membranes. There is, probably, no one pathological lesion that is pathognomonic of this disease.\*

The symptoms of the disease are *paralysis of motion, with loss of electro-muscular contractility, some anæsthesia, great diminution of temperature, and muscular atrophy*.

In some cases the muscular atrophy is accompanied by fatty degeneration.

Duchenne, with the aid of the microscope, has investigated the condition of the muscles in muscular atrophy. For this purpose a trocar



FIG. 116—Duchenne's Trocar.



FIG. 117—Noeggerath's Trocar.

is necessary. Duchenne's trocar, Fig. 116, is introduced into the muscle open. When *in situ*, a piece of sharp steel is pushed, by means of a button, against the barb of the trocar. A piece of muscle is thus caught, which, on the withdrawal of the trocar, can be examined.

*Microscopic Examination of Muscles.*—Noeggerath's instrument, Fig. 129, is introduced as a simple trocar, and when *in situ*, the wire contained in it, being pushed forward, causes the prongs or clasps on its extremity to emerge a little separated. When the wire is pulled out the prongs come together, bringing with them a piece of the flesh.

\* For a valuable résumé of the present state of our knowledge of the *Pathogeny of Infantile Paralysis*, see the paper on that subject by Dr. Mary Jacobi in the *Am. Journal of Obstetrics*, May, 1874.

We present the cuts of Duchenne, with condensed explanations.

Normal fibre.

—First degree.—

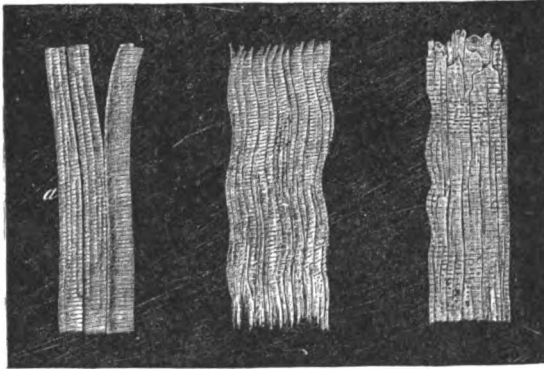

FIG. 118.

FIG. 119.

FIG. 120.

Fig. 118 “represents the normal fibres, with the transverse striæ.”

Figs. 119, 120.—“The transverse striæ are less distinct; they are frequently broken; the longitudinal fibres are more and more marked.”

Second degree.

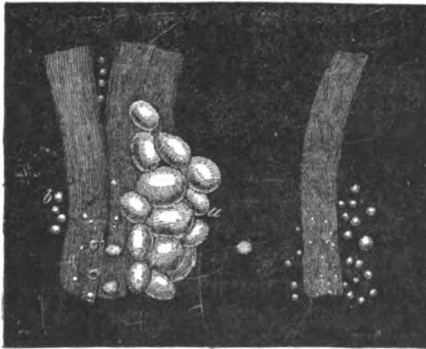

FIG. 121.

FIG. 122.

Fig. 121.—“The muscular fascia is composed entirely of longitudinal fibres, the transverse striæ having completely disappeared.”

“By the side of the muscular fibre adipose tissue is observed, composed of cells that are either (a) round or longitudinal; there are little drops (b) of fat deposited in the muscular fibre.”

Fig. 122.—“The muscular fibres have still preserved their contractility, and are undulating.”

## Third degree.

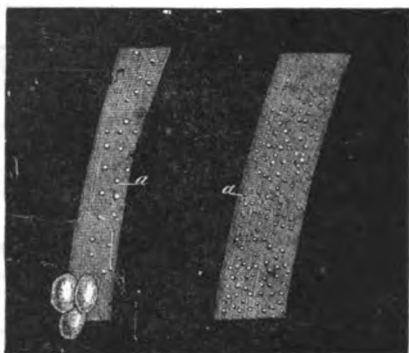

FIG. 123.

FIG. 124.

FIGS 123, 124.—“The longitudinal fibres have become less distinct. The molecules of fat are more and more abundant—again cover the figure almost entirely.”

## Fourth degree.

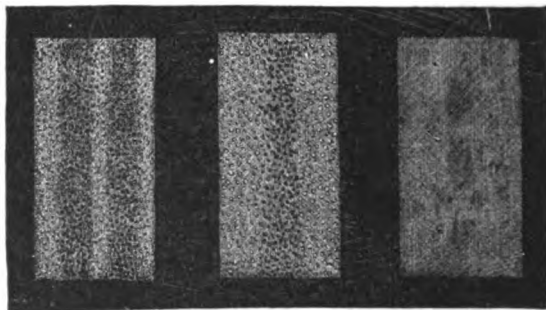

FIG. 125.

FIG. 126.

FIG. 127.

FIG. 125.—“The longitudinal fibres have disappeared. We see only fatty molecules very close together and little distinct, especially towards the axis of the fascia.”

FIG. 126.—“The fat becomes more abundant and difficult; the muscular fascia is more transparent.”

FIG. 127.—“Distinct molecules of fat are no longer perceptible; the fascia is composed of a shapeless mass.

“Each degree of fatty transformation corresponds to a degree of decoloration of muscular fibre.”

*Electro-Diagnosis.*—In infantile paralysis there is diminution or utter loss of electro-muscular contractility. In patients so young the condition of the electro-muscular sensibility cannot of course be ascertained

The tactile sensibility is in some cases much diminished; in other cases it does not appear to be affected.

A slight degree of anæsthesia cannot be ascertained in very young patients. An important feature of infantile paralysis is that the muscles exhibit contractility under galvanization when they are not at all affected by faradization. In this disease especially both currents are necessary in the diagnosis as well as in the treatment, and careful regard must be given to the "motor points."

In making an examination of the condition of the muscles of infants it should be remembered that, on account of their flabby character and the relatively large proportion of adipose tissue by which they are surrounded, they do not respond as readily nor as perceptibly to electrization as the muscles of adults.

*Treatment.*—Galvanization of the affected limbs is the method of electrization that is principally indicated in infantile paralysis. In those cases that fail to respond to the faradic current, the galvanic is indispensable. When the muscles have regained their contractility under the faradic current, faradization may be used either alone or alternately with galvanization.

Children will bear as powerful currents and as protracted localized applications, without apparent injury, as adults (see p. 550). No stronger currents should be used, however, than are just sufficient to produce full muscular contractions. *The most frequent mistake is to overdo the treatment—to use too strong currents, and too long applications, and thus weaken rather than strengthen the muscles.*

Galvanization of the spine is also indicated, and in connection with the peripheral treatment should not be neglected.

In infantile paralysis the general health is not necessarily impaired. Those cases that are accompanied with general weakness should be treated by general as well as localized faradization and central galvanization. Treatment by electrization is greatly aided by passive movements systematically and skilfully used, shampooing, frictions, and the application of dry heat and hot water to the affected limbs. (See remarks on Accessory Treatment under Hemiplegia.)

*Prognosis.*—The prognosis must depend on the cause, the probable nature of the lesion, the length of time that the disease has existed, and the condition of the muscles, especially as ascertained by electric and microscopic examination. If fatty degeneration is much advanced the prognosis is less favorable than when no degeneration exists.

Cases of a reflex or functional character may recover speedily without special treatment. Cases of organic character, which constitute

the majority, and which have gone on to atrophy, recover only slowly and under faithful, persistent treatment. It is rarely indeed that parents or guardians have the patience or the means to persevere and obtain the full benefit of which electrization is capable.

Frequently the improvement rapidly advances to a certain grade and then halts, or advances so imperceptibly as to discourage the parent.

*Paralysis of left arm ; atrophy of deltoid—No response at first to faradization—Improvement, but not recovery, under galvanization.*

CASE CXXXIX.—A boy aged 14 months, was suddenly taken with complete paralysis of the left arm after exposure to cold. He came under our observation about a week after the seizure. We found it impossible to produce the slightest contractions of the muscles with the faradic current. After two applications we resorted to the galvanic current.

Immediate contraction of all the paralyzed muscles followed its use, and the natural power was restored somewhat, so that the child was enabled to slowly close and open the hand. After another similar application, the faradic current was as efficacious in producing marked contractions as the galvanic.

When treatment had been continued about a month the child could use the hand and forearm perfectly well. The upper arm was considerably improved, so far as power of movement was concerned ; but the deltoid muscle had atrophied, and no subsequent treatment sufficed to greatly improve its condition.

*Paralysis of left arm, with atrophy of deltoid, caused by exposure to cold—No response at first to faradization—Improvement under galvanization.*

CASE CXL.—A short time before we saw the child he had been exposed (with bare arms and shoulders), while riding in the horse-cars, to cold draughts of wind. A few hours subsequently the mother first noticed that the child used the right arm altogether, and upon further examination she discovered that the left arm was perfectly powerless. Previous to the attack the little patient had been suffering considerably from the irritative process of teething, which had somewhat reduced him in health and flesh. The deltoid was atrophied. No intensity of the faradic current which we felt justified in applying to the affected arm produced the slightest effect ; but when a galvanic current of moderate power was made use of, the muscles of the paralyzed limb responded almost as readily as those of the healthy side. The improvement under the use of the galvanic current was for a time quite marked. He very soon regained full power over the hand and forearm, but was unable for a long while to move the upper arm, and when treatment was discontinued after some twenty applications had been given, it was impossible for him to raise the arm readily from the side. Notwithstanding the approximation to a perfect cure, the faradic current would produce only feeble contractions, while under the influence of the galvanic current the electro-muscular contractility was vigorous.

*Paralysis of right leg following diarrhœa—Rapid recovery under general faradization.*

CASE CXLI.—A girl, aged 14 months, was brought to us in September, 1867, to be treated for an attack of paralysis that occurred six weeks before. During the sum-

mer she had suffered from a diarrhoea, which had considerably reduced her in strength and flesh, and just a week before the leg became paralyzed she experienced a severe attack of cholera infantum. The mother of the child first observed some lameness of the right leg, that followed shortly after a fall from a chair. In two days the leg was without the slightest power of motion. The limb was cold. The improvement following electrization was in this instance unusually rapid. Two applications with the faradic current resulted in some progress; but after the third visit, when the galvanic current was used, the improvement was very marked. The muscles below the knee contracted vigorously for the first time under its influence, and in the course of three weeks, under the alternating use of the two currents, a perfect cure was effected.

*Paralysis of six months' standing—Entire loss of reaction to both currents—Approximate recovery.*

CASE CXLII.—Master C. E., aged four, was sent to us by Dr. S. H. McIlroy, of New York.

In September, 1877, the patient suffered from a severe attack of chills and fever, followed by convulsive seizures. One week subsequently the right leg was found to be completely paralyzed, the other limbs, with the exception of the left arm, being also affected, but in a less degree. In March, 1878, six months later, the case came under our care. The leg was apparently without life, quite cold, and atrophied to the last degree, while the electro-muscular contractility was completely abolished, and probably had been for some time. After a month's treatment by general faradization and localized galvanization, the general condition had somewhat improved, but there was not the slightest evidence of returning galvano-muscular contractility. In two weeks more, however, contractions, almost imperceptible, were observed. These increased very slowly, and it was six months before the muscles responded in the least degree to faradization. At the present time, after a year of the most persistent endeavor, the contractions are considerable, the limb has increased much in size, its circulation is good, and the child can, with the aid of a chair, move about quite readily. We conceive it to be self-evident that if this patient had not been treated with unusual persistency, or if active measures had been delayed much longer, a condition of life-long helplessness would have followed.

In consideration of the *absolute and long-continued paralysis, and loss of electric response to either current*, the above results have impressed us deeply, and should teach that even desperate cases of infantile paralysis should not be hastily abandoned to their fate.





## CHAPTER XXIX.

### DISEASES OF THE GENITO-URINARY ORGANS.

THE medical diseases of the male genital organs, for which electricity is chiefly indicated, are *spermatorrhœa*, *seminal emissions*, *impotence*, *incontinence of urine*, and *paralysis of the bladder*.

As it has been doubted whether the resources of the electrotherapeutics are capable of affording any decided and lasting benefit in these diseases, we here record not only as the result of our own experience, but from a knowledge of the experience of others, that no case in which there have been reasonable grounds for hope can be said to have been fairly treated, until the proper application of electricity has been attempted.

It should be remarked that of spermatorrhœa, seminal emissions, and impotence, the latter, taking the cases as we find them, yields the most uniformly and readily to electrical treatment. These three conditions are, however, very frequently associated, and the symptoms of each may be so intermingled as to render it difficult to decide which presents the most prominent indications.

*Spermatorrhœa*.—There can be no question that *true spermatorrhœa* is much less frequent than is generally believed. It consists of an involuntary discharge of semen without erection, and as there are several secretory glands besides the testicles, the secretion from which lubricates the urethral canal, and may even appear externally in a healthy condition of the parts, the activity of charlatans has had a fair field in which to excite alarm among the credulous.

*Seminal emissions* consists in an involuntary discharge of seminal fluid with erection, and demands treatment only when it becomes excessive, and is associated with, is dependent on, or is the cause of constitutional disturbance.

*Treatment*.—In regard to the treatment of spermatorrhœa and seminal emissions, it is hardly necessary to say that no one method of electrization will answer in all cases. The applications may be localized externally or internally, and in addition we frequently use with

advantage general faradization and central galvanization. There is one method of procedure concerning the ill effects of which we have positive convictions. We refer to strong galvanization of the ejaculatory ducts, or the parts in their immediate vicinity, by means of the insulated catheter electrode.

It is true that if employed with great caution, and with a current of very feeble power, no harm may result. Currents of considerable electrolytic power even may frequently be borne without any after ill effects; but it is equally true that these same applications, whether weak or strong, have in numbers of instances been followed by profound and lasting irritation.

Deaths have been known to result from the effects of the *porte caustique*. From the history of one of our cases, it seemed sufficiently clear that this treatment had laid the foundation of an obstinate stricture and in another case of complete destruction of the virile power, it was evident that the symptoms were in a measure due to a most severe and ill-advised cauterization of the ejaculatory ducts.

Electrolytic action is of course more completely under control, and although its action is different from that of the caustic, it is yet occasionally followed by substantially the same results, and we hesitate to make use of it in the irritable conditions that we are considering.

In lieu of this procedure, however, and in addition to the external methods of treatment, we are highly in favor of the direct application of the faradic current to the urethra, and on the same principles, and to meet the same indications, that the occasional introduction of the ordinary catheter is attempted. Mechanical pressure alone tends to unload the congested capillaries, and to very decidedly lessen the sensibility of the urethral nerves, and when combined with the vibratory action of the faradic current, we are convinced that its good effects are markedly increased.

*Impotence*.—The mildest and most frequent form of impotence manifests itself by a premature ejaculation of semen, with no special diminution of sexual desire, but with some impairment of the power of erection. A somewhat more persistent condition is shown by an appreciable diminution or capriciousness of the sexual appetite, with a marked decrease of the power of erection, and again there is not unfrequently an entire absence of sexual desire and power of erection. Another form of impotence may be termed *psychical*. The unfortunate subjects of this condition, ignorant of what the normal sexual appetite should be, often-times suppose that in their case it is deficient. Depressed and distracted

b, self-brooding, they sometimes fulfil their own dark forebodings, and fail in their preliminary attempts to accomplish the sexual act through the very intensity of their desire.

We shall not attempt to enter into any consideration of the causation of these symptoms, further than to say that the vast majority of cases of this character are brought on by the same general causes, masturbation, or suddenly breaking off the habit of masturbation, excessive sexual indulgence, prolonged continence, or by any influence that debilitates the system.

Not only in its incipient but in its more advanced stages, impotence not unfrequently is the result of organic disease of the nerve-centres, and its treatment by electricity is of importance only so far as it serves as an illustration of the extraordinary stimulating or tonic influence of the remedy. We have had patients suffering from incurable chronic hemiplegia, progressive muscular atrophy, locomotor ataxia, etc., where there has been, under local and general electrization, a most extraordinary increase in the desire and capacity for sexual intercourse.

*Electro-Diagnosis.*—*Anæsthesia of one-half, usually the left, of the penis*, is a condition not unfrequently observed in diseases of these parts. This may be detected by an electric examination or by the æsthesiometer. This peculiarity, which was first pointed out by Schulz, we have observed in a number of instances. With anæsthesia there may be coldness and blueness of the sexual organs.

Occasionally the anæsthesia is quite profound, and as a rule the sexual weakness is in proportion to the degree of the anæsthesia.

The numbness in these cases is more than an accidental association; it would indeed appear as if it were, to a certain extent, a cause; for by the application of the ordinary electric brush to the parts in the same way that we treat any case of local anæsthesia, the numbness is often removed, and the integrity of the sexual function restored.

*Hyperæsthesia* of the urethra is a condition that is sometimes observed, especially in patients otherwise nervous and irritable.

In the worst stages there may be atrophy of the testicles and the penis, and a diminution of temperature that is at once perceptible to the hand.

*Treatment.*—In the consideration of the various degrees of impaired sexual power, the question at once arises, What are the indications, and how are these indications to be fulfilled? In the milder forms of impotence, where there is simply premature ejaculation of semen, with some diminution of the power of erection, as well in the more advanced

stages, where the desire is capricious and the power of erection pretty well destroyed, it is evident that there must be a degree of paralysis at the root of the disorder, dependent on structural changes in the nerve-centres, or else this impaired power or tone in the muscles and erectile tissue may be of a purely local character. In the latter case, the indications are clearly the same as in other forms of local paralysis, and by faradization of the ischio-cavernosus and bulbo-cavernosus muscles much may be accomplished. In recent cases of impotence, where there is considerable power remaining, as well as in a more advanced stage, where the power is approximately lost, we not unfrequently find that the seminal secretion is markedly reduced, not only in quantity but quality; and, reasoning from analogy, it would seem that in such cases there were undoubted indications for the use of electricity.

The galvanic current especially has the power of exciting to increased activity the secretory function of various glands, and not seldom accelerates physiological mucous discharges. The salivary and lachrymal glands, as well as the liver, are susceptible to stimulation by electrization, and it is undoubtedly true that the lacteal secretion has been augmented by passing the current through the breasts of nursing women. (See chapter on Nutrition in Electro-Physiology.)

It is highly probable, then, that a deficiency in the secretion of semen when it is dependent on local paralysis or exhaustion of the nerves controlling this function, and not on pathological changes of a structural character, may be successfully remedied by galvanizing the spermatic nerves and testicles. We cannot, however, in all cases, depend on local treatment alone. Not only may impotence be associated with, but it may result wholly from disorders of a general character. The excessive use of sedative narcotic remedies, sedentary habits, and general malnutrition from any cause, lead to the condition under consideration, and demand the general constitutional tonic influence of general faradization.

The vesiculæ seminales and the testicles may be affected, and in some patients very powerfully and sensibly, when one of the poles is applied to the lower part of the spine, and the other to some point on the thigh or against the perinæum. A very good way to affect the male reproductive organs is to apply one pole firmly against the perinæum, and the other upon the testicles.

Faradization of the genital organs should not usually be protracted longer than five to ten minutes; galvanization from two to eight minutes. The faradic current would appear to be preferable. Impotence,

like seminal emissions, may sometimes be treated by connecting the steel sound introduced into the urethra with one of the poles of the faradic current, thus combining the toning effect of pressure with the toning effect of electricity on the relaxed parts.

*Aspermatism.*—Impotence, as before remarked, may manifest itself by many symptoms, and in various degrees; but there is one phase of it that is, we believe, not very common. It consists in an inability to ejaculate semen while the power of erection remains vigorous, and to this condition the term, aspermatism, was first proposed by Roubaud in 1855.

Dr. Wm. H. Van Buren, in an article published in the *New York Medical Journal* for November, 1868, suggested that the difficulty in ejaculating the semen was caused by an exaggerated spasmodic contraction of the muscular fibres of the walls of the ejaculatory ducts, leading to their occlusion under extreme excitement. On this theory it would seem that the indications called for galvanization of the ejaculatory ducts; but in two cases that have come under our observation, and that might fairly be placed under the head of this affection, the treatment failed to afford relief.

*Spermatorrhœa associated with profound mental and physical depression—Rapid recovery under general and localized faradization and central galvanization.*

CASE CXLIII.—Mr. T—, a youth aged 17, came under our care April 23d, 1873, for the relief of spermatorrhœa associated with profound mental and physical depression. The patient was of a highly nervous organization, and attributed his symptoms mainly to the vice of masturbation, which he had practised for a number of years. The muscles were in a flabby condition; there was marked anæmia, and his strength hardly permitted him to walk half a dozen blocks without the onset of a paroxysm of cardiac palpitation with utter exhaustion. The mental faculties were weakened, and at the same time his feelings were in such a condition of hypochondriacal depression that he would allow no hope of recovery to enter his thought. Emissions of semen occurred regularly two or three times a week. The patient was immediately submitted to general faradization with alternations of central galvanization and localized faradization. At the end of a month's treatment it was found that there had been but three seminal emissions, and during the last two weeks none at all. He had become decidedly hopeful, and could exercise both mind and body to a far greater extent than for six months before. The treatment was discontinued, and the patient left the city for his home. As is the usual course known under simi-

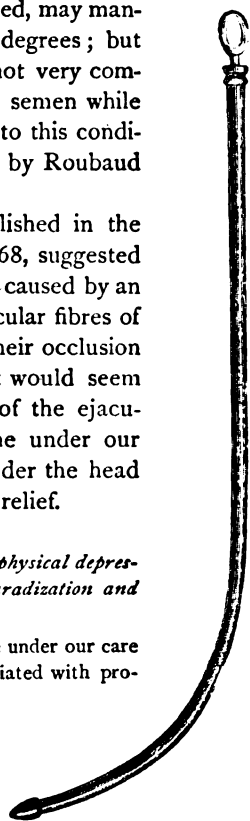

FIG. 128.

Insulated Catheter Electrode

lar conditions, the improvement continued uninterruptedly, and before the close of the summer a perfect recovery was complete.

*Spermatorrhœa associated with extreme nervous exhaustion of three years' standing—Improvement under general faradization and central galvanization.*

CASE CXLIV.—G. H. W., a young man, aged twenty-five years, came to us September 19th, 1871, complaining of a persistent spermatorrhœa, associated with great physical and mental depression. Three years before, he first observed a decided weakness of the eyesight, together with occasional nocturnal emissions of semen. It should be stated that these symptoms immediately followed a severe attack of inflammation of the bowels, with enlargements of the mesenteric glands. All his life he had indulged in masturbation to a considerable extent. His nervous system had been so completely upset that for three years he had been unable to study or to work, and as medication and the influences of travel and change had failed to benefit him, he began to despair of recovery, and became tenfold more despondent, and was so reduced physically that he was unable to walk more than two or three short blocks without a sense of utter exhaustion and a soreness and "drawing down" in the abdomen that was absolutely painful. Seminal emissions occurred almost every night, and added immensely to his misery, both mental and physical. As an evidence of the excessively sensitive condition of the central nervous system, it may be stated that a faradic current of moderate strength applied to the sacrum and lumbar region produced by reflex action a decided tingling sensation in several remote parts, and especially on the crown of the head. The patient was submitted to general faradization, and under the influence of a dozen applications improved considerably in strength of mind and body. Subsequently many similar applications accomplished nothing more for him. Galvanization of the brain, sympathetic, and spinal cord was then resorted to. A new impetus seemed to be immediately imparted. The emissions became less frequent, and finally occurred so seldom as to occasion little remark. The power of continuous thought returned, and at the end of another month, he left us apparently recovered.

*Failure of the sexual power and spermatorrhœa associated with hypochondriasis—Recovery under central galvanization and localized faradization.*

CASE CXLV.—Mr. — came to us by the advice of Dr. John Byrne. For several years he had been affected with an excessive irritability of the genital organs, in consequence of which he had become both physically and mentally depressed. Involuntary ejaculations of semen were frequent, and occurred generally during sleep at night, while the ability to perform satisfactorily the act of coition seemed almost inert.

The patient was treated by central galvanization and by faradization localized directly through the genital apparatus.

The beneficial results of the treatment were soon most decidedly manifested. The involuntary emissions ceased in the course of a month almost entirely, and the sexual power returned in full force. As a natural result, the mental balance was restored and the patient left us quite hopeful and happy.

*Congenital impotence, with the sexual instinct unimpaired—No improvement.*

CASE CXLVI.—A very interesting case of congenital impotence fell under our observation in February, 1872.

The patient was a young man aged 30, and although the sexual instinct was fully developed, and a strong feeling of sexual desire had been manifested from his earliest manhood, yet he had never at any time been able by artificial means to excite any orgasm, or the slightest ejaculation of semen.

Actual intercourse had never been attempted.

He was subject to occasional nocturnal emissions, that were accompanied, however, by no pleasurable sensations. Structurally the parts seemed to be in every way perfect, and the fault undoubtedly lay in some original imperfect condition of the nervous supply.

No benefit was derived from treatment.

*Almost complete impotence in a patient aged 45—Perfect recovery under localized faradization and galvanization of the spine and sympathetic.*

CASE CXLVII.—Mr. X., aged about 45, was directed to us by Dr. James Anderson, in the spring of 1872. The patient was a stout, vigorous man, and the father of several children, but for some years he had observed a gradual but decided decrease of sexual power, and at the date of his application for treatment he asserted that he was almost completely impotent. We submitted him on alternate days to localized faradization and galvanization of the lower portion of the cord, and occasionally extended the galvanization to the neck in order to bring more or less completely under the influence of the current the sympathetic system. This method was faithfully followed out for some six weeks. Week by week the patient observed increasing sexual capacity, and at the close of the treatment, when he departed for Europe, he claimed to possess perfect sexual vigor.

He has suffered to this date, 1874, no relapse.

*Diminution of power of erection in a married man in the prime of life—Cephalalgia and debility—Recovery under general faradization.*

CASE CXLVIII.—Mr. —, a merchant in the prime of life, and to all appearances enjoying excellent health, consulted us for inability to perform satisfactorily the act of coition. This inability did not involve an absence of sexual desire, but simply a want of power to obtain and retain an erection. This gentleman had a family of several children, and since his marriage, many years before, had led, according to his statement, a correct and regular life. He attributed this premature decline to early excessive indulgence and abuse of the generative function. His outward appearance belied his general condition, for he suffered much from headache, and oftentimes, on rising in the morning, from considerable enervation.

General electrization was decided on and given, together with local applications. He continued treatment for three weeks, receiving an application every other day. The result was entirely satisfactory. His general condition was so much improved, and the vigor of his sexual organs was so much increased, that he was enabled to complete the marital act as satisfactorily as in his youth.

*Impotence of twenty years' standing caused by local paralysis—Numbness and coldness of the parts—Deficient power of erection—Slight seminal secretion—No improvement under galvanization and faradization.*

CASE CXLIX.—Mr. —, aged 44, was sent by Dr. Jerome Smith to be treated for impotence of nearly twenty years' standing. When but 17 years old he contracted

gonorrhœa, and at the age of 25 was attacked by syphilis. At that time he led a very dissipated life, and no sooner was an attack of this disease apparently cured than he forthwith subjected himself to another. During the last attack the solid caustic had been introduced into the urethra. This cauterization produced excessive inflammation and pain, and was followed by complete impotence, associated with a feeling of numbness and coldness in the penis. He had tested nearly all remedies, and at one time, by the advice of Dr. Brown-Séquard, he had used hot and cold douches, but all without avail. When he came to us the penis was quite cold, and much below the natural size. Erection was occasionally possible, but he was never able to accomplish the marital act. The testes were of an almost natural size, and when the penis was artificially excited, a small amount of semen would appear. The penis was apparently paralyzed, and the impotence was manifestly due to that cause more than to the want of seminal secretion. The patient was a stout, hardy, vigorous man, of a full habit, and quite a free liver; and neither in his countenance nor in his general bearing betrayed the slightest effects or even consciousness of his affliction.

Four applications of the faradic current were given, with the effect of temporarily increasing the warmth of the penis, and nothing more. The galvanic current was then tried. It increased the circulation in the penis, and consequently heightened the temperature more than the faradic current, but no permanent benefit resulted. Our patient then discontinued the treatment, owing to the pressure of his business engagements. He would have persevered, however, if we had felt warranted in holding out reasonable chances of a successful result from a long course of electrization.

*Premature discharge and deficient secretion of semen, caused by excessive sexual indulgence—Recovery under external and internal galvanization and faradization combined with medical treatment.*

CASE CL.—Mr. —, aged 27, formerly a gymnast, and latterly a printer, consulted us in May, 1870, for sexual weakness brought on by abuse of the organs. The discharge was premature, and with less excitement than usual, and there was a manifest deficiency of secretion. The patient was exceedingly muscular, and his general health was almost perfect. For that reason only local treatment was employed. The organs were faradized in the various methods twice a week, and once a week internal galvanization was employed, the metallic extremity of the catheter electrode being directed as near as possible to the orifices of the ejaculatory ducts. At the same time the patient was directed to take a mixture of bromide of potassium and wine of ergot. Under this combined treatment the recovery was complete in twenty-five applications.

*During the latter part of the treatment the patient observed, during sexual intercourse, a very great increase in the quantity of semen discharged.*

*Diseases of the Bladder.*—The diseases of the bladder for which electrization is chiefly employed are *incontinence of urine* and *paralysis*.

Incontinence of urine depends on an irritable condition of the neck of the bladder. While it largely sympathizes with other diseases and the general health, being frequently associated with hysteria and spinal



irritation, it is yet oftentimes a purely local affection. There are various grades of the disease, from simple irritability that makes it necessary to pass the water with unusual frequency, to utter inability to sleep through the night without unconsciously "wetting the bed." The former condition exists mostly in adults—especially in the hysterical and the aged; the latter is peculiar to the period of childhood. It is probable that the pathological condition in children who nightly void their urine in bed, is not necessarily worse than that in adults who only complain of being obliged to pass the water with abnormal frequency. The unpleasant results in children are due to their profound sleep or deficient self-control. That the pathological condition in children is not always of an important character is proved by the fact that it sometimes yields to purely moral influences.

In the treatment of incontinence of urine, both external and internal applications may be used. In the majority of cases the internal applications by means of the catheter electrode (p. 567) are not required. It is needless to say that in young children the introduction of the catheter electrode is attended with difficulty. The treatment we prefer is faradization with strong currents through the neck of the bladder. In males one pole may be placed over the symphysis pubis, and the other at the perinæum; in females one pole may be applied over the symphysis pubis and the other at the lower part of the sacrum. Cases associated with hysteria, or dependent on spinal disease, need central and general electrization.

*Prognosis.*—The prognosis of young and recent cases is usually good. Long-standing cases also yield, but need correspondingly longer treatment, and are liable to relapse. Cases complicated with constitutional or central disease, which are, of course, mostly found in adults, have either a favorable or unfavorable prognosis, according to the nature of the malady with which they are complicated.

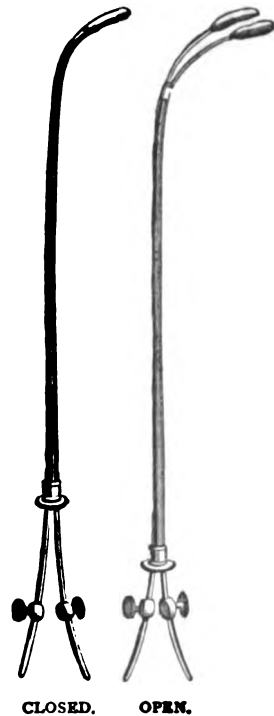

FIGS. 129, 130.  
Double Vesical Excitor or Electrode (Duchenne).

*Paresis\* and Paralysis.*—Paresis and paralysis of the bladder so frequently depend on incurable diseases of the spine, that the prognosis is, as a rule, unfavorable as regards a complete cure. Relief and improvement, even in very bad cases, may be gained by faithful treatment, but entire recoveries are exceptional.

The *treatment* should be external and internal, with both the galvanic and faradic currents, combined with central galvanization.

*External* applications may be made, placing one pole, the negative, over the symphysis pubis, and the other on the back, or at the nape of the neck, and passing very strong faradic currents with interruptions.

*Internal* applications may be made either with the insulated catheter electrode, or with Duchenne's double vesical electrode (Fig. 129).

The catheter electrode may be connected with the negative pole while the positive is at the hypogastric region or back. By means of the double exciter of Duchenne the current can be more exclusively localized in the muscles of the bladder than by any other method.

*Gonorrhœa.*—It would not be unreasonable to suppose that gonorrhœa in its subacute stage might be treated by electrization with at least as satisfactory results as subacute inflammations of the mucous membrane.

We have had opportunity to test faradization in three cases of gonorrhœa while the inflammation was in quite acute stages.

*Gonorrhœa—Temporary increase of secretion under faradization—Recovery.*

**CASE CLI.**—A gentleman requested us to try on him electrical treatment for an attack of gonorrhœa that he had recently contracted. We consented to do so, with the understanding that the treatment should be considered as experimental, inasmuch as we had treated but one case of gonorrhœa by electricity.

We employed local external faradization through the penis, without regard to the direction of the current. After four applications he represented that he was cured. In this, as in another case, there was some temporary increase of the urethral secretion after the first two applications.

These cases may be taken for what they are worth; they are the only cases of the kind in which we have ever attempted electrical treatment.

*Chronic urethritis (gleet)* we have treated by mild galvanization with the catheter electrode and sounds, and with encouraging results. Electricity thus used acts well as an adjuvant to the other treatment, just as in catarrh of the nose, granular lids, chronic inflammation of the middle ear, and analogous conditions.

\* From *pareisis*, exhaustion.

*Syphilis.*—The severe pains of secondary syphilis are to a certain extent relievable by general and localized faradization, as we have demonstrated in a few instances; concerning the permanency of their effects we have as yet no positive evidence.

(For the treatment of syphilitic ulcers, see *Ulcers.*)

*Buboës* may be discussed by external faradization, and have been so treated by Hassenstein.\* Chovstek has used galvanization.

*Orchitis.*—The electric treatment of orchitis has been particularly studied by Drs. Jules Chéron and Moreau-Wolf.†

They give the results of the treatment in nine successful cases. Their method of treatment was to direct a galvanic current from ten to twenty-four cells of Remak, through the tumor, from two to eight minutes. Sometimes the positive pole was placed on the most painful point of the swelling, and the negative on the spermatic cord. The authors regard the ascending current (up the cord) more effective than the descending.

Most of their cases were cured by a few (from four to ten) applications.

The great advantage which the authors claim for this method of treatment in orchitis is, that the patient is *not obliged to suspend his daily duties, since absolute repose is not necessary.*

*Chronic orchitis of six months' standing in a syphilitic patient—Approximate recovery under external galvanization and faradization.*

CASE CLII.—Mr. W., aged 28, consulted us in October, 1870, for an enlargement of the left testicle that had troubled him for six months. It was about twice the size of the right testicle. There was no pain, but a constant sense of weight. The patient was suffering from secondary syphilis, and had, in times past, repeatedly experienced attacks of gonorrhœa. Stable galvanization with a current that was comfortably borne was employed for ten minutes, the positive pole being applied over the testicle at different points, and the negative pole over the spermatic cord. The patient stated that the testicle felt less disagreeable. In two days there was an apparent diminution in size. Three more similar applications and one faradization produced an almost complete recovery.

*Enlargement of the Prostate.*—The electrical treatment of hypertrophy of the prostate has been studied by Tripier,‡ who has demonstrated that the effect of faradization of this organ when enlarged is to cause resolution. The rationale of the treatment is substantially the same as for analogous conditions of the uterus. The subject is one

\* Chemisch-Electrische Heilwerke, Leipzig, 1853.

† Du Traitement de l'Orchite, par l'application des courants continus constants, Paris, 1869.

‡ Manuel d'Électrothérapie, p. 567.

that deserves investigation. Either the galvanic or the faradic current may be employed. One pole may be applied internally by means of an insulated catheter electrode or sound, and the other in the rectum against the prostate, by means of a rectal electrode. We have treated one case of enlarged prostate by internal and external faradization. The patient, a medical gentleman about sixty years of age, was seen and examined by Dr. Gouley, who confirmed the diagnosis of enlarged prostate. We treated him a number of times by external faradization—one pole on the symphysis pubis and the other on the perinæum—and by internal faradization, one pole in the rectum—insulated except at the point where it came near the prostate—and the connection made in the prostatic portion of the urethra, by a flexible sound, passed through a gum elastic catheter, according to the suggestion of Dr. Gouley. Applied in this way the electrodes were very near to each other and in sensitive localities, and only *very feeble currents could be borne*, and sometimes slight hemorrhage followed the treatment in spite of all the caution that was exercised. It was found impossible to use sufficiently strong currents by this method to produce any effect, and again we returned to partly external faradization. This treatment, which seemed to aggravate a cystitis that existed, was abandoned.

Dr. Mittendorf, of this city, informs us that he has obtained decided results in enlargement of the prostate, in two cases. He used external faradization—one pole over the symphysis pubis and the other at the perinæum.

*Diseases of the Rectum.*—Electrization has been used for *prolapsus ani*, *paralysis of the sphincter*, and *hemorrhoids*.

The current can be very well localized in the rectum by means of a rectal electrode (see p. 531), which may or may not be partly insulated. The rectum is but little sensitive, and will bear strong currents. The rectum may also be treated by a double rectal exciter, analogous to that which is used in the bladder. When a single electrode is used, one of the poles should be placed on the spine.

*Prognosis.*—Paralyses of the sphincter that depend on local disease, like paralysis of the bladder depending on the same cause, rarely offer a perfectly favorable prognosis.

In *prolapsus ani* Benedikt \* claims a few mostly good results. We have treated one long-standing case without benefit.

*Hemorrhoids.*—Piles, external and internal, may be treated by both currents applied internally. Relief of itching, pain, and permanent improvement in the tone of the parts are derived from this treatment.

\* Op. cit., p. 482.

## CHAPTER XXX.

### DISEASES OF THE LARYNX

THE disease of the larynx, for which electrization has been almost exclusively used, is *aphonia*, a condition which arises from many morbid states.

*Anæmia and Inflammation.*—External electrization of the throat is of service as an adjunct in the treatment of inflamed and irritable conditions of the larynx, but only in rare cases has it been thus employed. We have found that faradization of the neck, for from two to five minutes, has an appreciable and agreeable effect in diminishing the irritation produced by cauterization, and when continued exerts a tonic influence on the organ. In cases of diseases of the larynx, connected with hysteria or anæmia, the local treatment is materially aided by general faradization.

Subacute and chronic inflammations of the pharynx are also treated with some success in the same way, and on the same principles.

*Method of External Electrization.*—The larynx may be electrized externally by various positions of the electrodes. One pole may be placed at the back of the neck and the other just above the manubrium sterni, or the poles may be pressed against the larynx by the inner border of the sterno-cleido-mastoid muscle, or one of the poles may be in the hand of the patient. These methods are best adapted for the purposes of producing a sedative or tonic effect on the inflamed and irritated membranes. We have frequently used this treatment, for about five minutes after the application to the larynx of irritating caustics, with satisfactory results. There is no question that the faradic current, employed perseveringly by these methods, and in cases of anæmia and general debility, by general electrization, will alone accomplish something in anæmia, subacute inflammations, and nervous debility of the larynx.

*Aphonia.*—There are few local disorders that yield more uniformly or readily to any method of treatment than aphonia to electrization. In order, however, to form a correct idea of its value in these cases, or to

intelligently communicate the results of electrical treatment, it is necessary to have not only a knowledge of the general nature of the disease but to appreciate, so far as possible, the exact pathological condition of each individual case. Above all, it is necessary to decide whether the symptom is of an organic or of the so-called functional character. Mackenzie, who has had an extended experience in nervous affections of the larynx, and their treatment by electrization and otherwise, adopts the following nomenclature of the paralyzes of the muscles acting on the vocal cords : \*

1. Bilateral paralysis of the adductors.
2. Unilateral paralysis of the adductors.
3. Bilateral paralysis of the abductors.
4. Unilateral paralysis of an abductor.
5. Paralysis of the tensors.
6. Paralysis of the laxors.

The *first* of the above-mentioned pathological conditions of aphonia is supposed to depend most frequently upon hysteria and debility, and readily yields to treatment. In these cases, however, which are too frequently but the local manifestation of a constitutional disorder, it has been our custom to rely on general as well as localized electrization.

Central difficulty is rarely a cause of bilateral paralysis of the adductors, but it is not uncommon in certain stages of phthisis. In 37 cases of phthisis, examined by Mackenzie, in which the voice was affected, he found that in 26 there was thickening or congestion of the mucous membrane of the larynx, while in 11 the affection was purely functional. Aphonia, then, coexisting with pulmonary tuberculosis, may often be readily relieved by local treatment alone.

Hysteria and debility are not so frequently the cause of unilateral paralysis of the adductors as of the first-named condition. This second cause of aphonia, however, may be due not only to phthisis, but to toxæmic poisoning, to syphilis, to cold, to muscular strain, and even to cerebral disease. We would naturally infer that this form of aphonia would be more persistent than the first-named.

Clinical experience has confirmed this inference.

Bilateral paralysis of the abductors of the vocal cords has, unfortunately, for its causation, in the majority of cases, some central difficulty.

The prognosis is of course most serious, but fortunately this condition is very rarely met with. Unilateral paralysis of an abductor, although depending on the same general cause as the bilateral form, yet, more frequently than the last-named, it is excited by some peripheral irritation, as pressure on the pneumogastric nerve, or upon one recurrent nerve, by an aneurism of the arch of the aorta. The prognosis in these cases is also unfavorable.

Paralysis of the tensors and laxors (both the bilateral and unilateral form) are supposed to result, in the majority of cases, from a too prolonged or violent use of the voice. Both are said to be quite amenable to treatment.

\* On the Laryngoscope, etc., p. 183. Also Hoarseness, Loss of Voice, and Stridulous Breathing, in Relation to Nervo-Muscular Affections of the Larynx. 1868.

Spasm of the muscles controlling the vocal cords is an additional cause of aphonia.

*Treatment.*—Mackenzie's method is to make the application directly to the cords by means of laryngeal electrodes (p. 632) devised by him. He uses the faradic current.

The direct application of electricity to the vocal cords is undoubtedly more efficacious in restoring loss of voice than simple external application. This latter method is, however, underrated when it is said that it "*seldom* restores the voice when it has been lost any length of time." Several cases that we have treated at various times illustrate very decidedly the beneficial results that may follow external applications, even in cases where the disorder has persisted several months. We are the more gratified to be able to make this statement from the fact that the external is much more readily performed by the operator than the internal application, and is far more agreeable to the patient. It is far better at first, in all ordinary cases, to make use of the external method; and if it does not succeed, it is time enough to resort to the direct application. The instrument of Mackenzie is thus described in his own words:

"It consists of two parts, viz., the necklet, which the patient wears, and to which one chain of the battery is attached, and the laryngeal electrode itself, which is connected with the other conductor. The electrode is so constructed (see cut) that the current does not pass beyond a certain point until the pole is seen, in the laryngeal mirror, to be upon the vocal cords, when the operator touches a little spring in the handle, and the current immediately passes through the laryngeal muscles. The necklet should be worn rather low, so that it covers the sides of the cricoid cartilage, and the space between it and the thyroid. In this way the lateral adductors of the cords (crico-arytenoidei laterales) can be most easily reached; and the arytenoideus proprius, or central adductor, may be electrified by placing the pole on the posterior surface of the arytenoid cartilages.

"I generally keep the pole in the larynx for three or four seconds each time it is introduced, and pass a succession of short, rapid shocks through the larynx; and at each sitting I apply the pole to the interior of the larynx three or four times."

Mackenzie is of the opinion that the effects are of a *reflex* as well as direct character.

Meyer\* reports successful results in the treatment especially of hysterical aphonia by the electric moxa, applied to the larynx.

\* Op. cit., p. 436 et seq.

Some of his cases were cured by a single application ; in others a course of treatment was required. Tobold speaks favorably of the

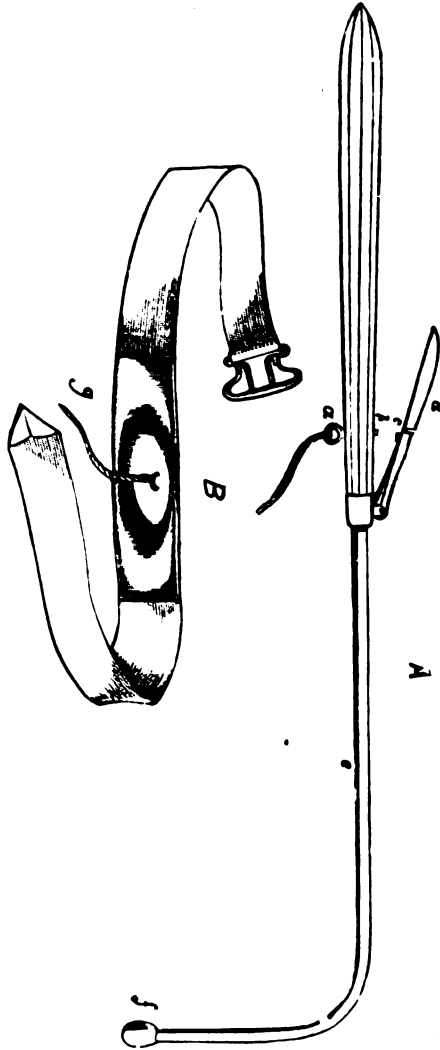

FIG. 131.

Laryngeal Electrode and Necklet.

*A* represents the electrode (No. 1). The instrument is connected with the electric apparatus by the connecting wire at *a*. When the insulated handle is pressed upon, the circuit is closed by the junction of *c* and *b*, and the current passes to the metallic point *f*. The wire *c* and the handle of the electrode are insulated. *B* is the necklet.

Mackenzie has also devised another form (No. 2) of electrode, in which the two poles are united in the same instrument, after the manner of Duchenne's *double vertical electrode*.

electric moxa in hysterical aphonia. It should be borne in mind that in hysterical aphonia any form of irritation, external or internal, elec-



trical or otherwise, may cause instantaneous cure. Some of the most brilliant achievements of mesmerizers and of those who practise laying on of hands and other flummeries, have been made in hysterical aphonia.

*Kind of Current to be Employed.*—For electrization of the larynx, externally and internally, both currents have been used with success.

#### IRRITATION OF THE MUSCLES OF THE LARYNX.\*

*Crico-thyroid.*—This muscle may be caused to contract by applying pointed electrodes by the conoidal ligament. The effect of the contraction is to cause the annular and thyroid cartilages to approach each other.

*Arytenoid Transverse*, at the posterior surface of the arytenoid cartilages. The effect of the contraction of the muscles is to cause the cartilages to approach each other.

*Crico-arytenoid and Thyro-arytenoid muscles*, in the sinus pyriformis, between the posterior border of the thyroid cartilages and the plate or surface of the cricoid cartilages.

*Crico-arytenoid Posterior* (dilator of the glottis), downward and backward from the sinus pyriformis.

*Crico-arytenoid lateralis*, in the sinus pyriformis on the exterior border of the surface of the annular cartilage. Contraction of these muscles produces rotation of the cartilages of the larynx, with movement of the vocal cord toward the median line.

*Thyro-arytenoid*, beneath the anterior superior border of the crico-arytenoideus lateralis. Contraction of this muscle brings the cartilages of the larynx forward and downward, and narrows the glottis.

*Thyro-epiglottic and ary-epiglottic muscles*, at the border of the epiglottis.

*Prognosis in Aphonia.*—The prognosis in aphonia depends entirely on the pathology. In *functional* (bilateral paralysis of the adductors) aphonia the prognosis is more favorable than in almost any other disease that is known to science. The majority of cases will recover, whether external or internal applications are used, although Mackenzie contends that the recovery is much surer and speedier than when only internal applications are used. He says, out of more than *two hundred* such cases he has succeeded in all except four. In some of these cases the aphonia was of six, seven, and even eight years' standing.

\* The subject of direct electrization of the laryngeal muscles has been studied by Ziemssen. *Elektricität in der Medicin*, 1866.

In *unilateral paralysis of the adductors* the prognosis is good when the origin is local, and bad when it is central.

In bilateral paralysis of the abductors and *unilateral paralysis of the abductor* the prognosis is unfavorable.

In *paralysis of the tensors of the vocal cord* the prognosis is usually favorable.

In *paralysis of the laxors of the vocal cord* the prognosis is on the whole favorable, but much time is required.

*Aphonia of four months' standing, caused by exposure to cold—Recovery after three external faradizations.*

CASE CLIII.—Miss F., a robust young lady of 18, consulted us in October, 1868, for a persistent and an almost complete aphonia, from which she had been suffering without any relief for four months.

She stated that on the evening of the attack she was enjoying a sail with a party of young friends on one of our rivers. She had for some time previously complained of slight irritation of throat, but it caused but little annoyance. The evening was somewhat damp, and the patient carelessly uncovered her head during the whole time the party remained in the boat. While singing, and endeavoring to strike a very high note, she felt as if something in her throat had "relaxed or suddenly given way." For one week she remained so completely aphonic that she could not utter an intelligent word. In the course of another week, however, she could speak at times so as to be understood, but only with considerable difficulty, and not above a *very* feeble whisper. At this point all improvement ceased, and no form of medication, or external or internal application, seemed to be of any benefit whatever. Laryngoscopic examination revealed the following condition of the parts affected: On attempting to speak the right vocal cord remained almost if not quite motionless, while its fellow approached the median line. It was evident from the feeble and imperfect working of the left cord, that it also was considerably involved and doubtless had been completely paralyzed. The surrounding tissues were considerably congested.

The negative electrode was placed upon the spine, between the shoulder-blades, and, using our fingers as electrodes, we passed a steady current through the neck for about ten minutes. At the conclusion of the séance, the patient could speak in quite a loud whisper, and a second examination with the laryngoscope revealed the fact that the right vocal chord perceptibly approached the median line during the act of phonation. The voice of the patient gained strength rapidly, until, in four days, and after receiving but two similar applications, she was able to speak as loud and sing as vigorously as ever.

*Aphonia following diphtheria—Rapid recovery under direct faradization of the muscles of the glottis.*

CASE CLIV.—Miss G., aged 22, and suffering from functional aphonia subsequent to a slight diphtheritic attack, consulted us in the spring of '71. Her inability to speak above a whisper had existed some two weeks.

Examination with the laryngoscope revealed bilateral paralysis of the muscles, clos-

ing the glottis, with a slightly congested condition of the surrounding tissues. The patient was anæmic, and excessively nervous, and in the treatment we alternated general faradization with direct faradization of the muscles of the glottis.

The tonic effects of these applications were soon manifest, not only in the laryngeal muscles, but upon the system generally as well.

She gained rapidly in nervous vigor, and within two weeks her strength of voice entirely returned.

Dr. F. I. Knight,\* of Boston, has reported a case of complete paralysis of one recurrent laryngeal nerve, and partial paralysis of the other, that was benefited by the galvanic current locally applied.

The following case we transcribe from Mackenzie's work :

*Dysphonia of a year's duration, from paralysis of the laxors of the right vocal cord cured by electricity.*

"Madam C—, aged 34, a professional singer, consulted me in May, 1865, on account of a difficulty she had experienced during the last year in forming her lower notes. Her voice in the ordinary way extended from *d* above the line to *a* below. A year ago she first experienced slight difficulty in forming the lower *a*, and in January she could not reach beyond *b*. During the last two months she had not been able to sing at all, even in private. She broke down directly she attempted even a few notes. She attributed the loss of power to a strain, as she first noticed the difficulty after the performance of a long and trying cantata, which had been twice encored. At the time she had experienced 'a stinging sensation, extending from the right side of the throat up towards the ear.'

"She had been constantly under treatment since her voice first became affected. The only thing which had seemed to do her good was a solution of caustic applied to the throat with a piece of sponge at the end of a whalebone rod. But though this treatment always gave temporary relief, there was no permanent improvement. On making a laryngoscopic examination, the parallelism between the vocal cords was seen to be lost, the right cord curving away in the centre from the median line.

"The treatment (direct electrization of the right vocal cord) was long and tedious in this case. At the end of six weeks there did not appear to be any improvement, and I should have given it up had not the patient most earnestly begged of me to continue a little longer. I was glad that I did so, for a fortnight later the patient perceived a marked improvement in the voice. In order to test the voice I used to allow the patient to sing a few notes once a week, but at no other time. At the end of three months the voice was decidedly improved, and the following autumn the voice was so completely restored that the lady was able to accept an engagement in Madrid."

*Spasmus Glottidis (Laryngismus Stridulus—Spasm of the Glottis.)*—In this affection, which is acknowledged to be of a nervous character, electrical treatment is indicated on the same principles on which it is indicated in *torticollis*, *writer's cramp*, and *facial spasm*.

The disease is caused by any influences that depress the system.

\* See Archives of Electrology and Neurology, May, 1874.

In children it may arise by reflex action from the irritation of teething or of worms ; in adults it is often an accompaniment of hysteria, and arises from diseases of the sexual organs.

*Treatment.*—General faradization and galvanization of the sympathetic, and external galvanization and faradization of the larynx by any of the methods previously described.

Tobold reports success with peripheral and central galvanization in this disease. A strong maiden, 23 years of age, who was attacked regularly every night with severe spasms of the larynx, was entirely cured in four weeks by galvanization.

*Nervous Cough.*—Electrical treatment is sometimes excellent for nervous coughs of various kinds. External faradization or galvanization or central galvanization are indicated.

The following unique case may as well be inserted here :

*Spasmodic cough, unique in character, and of unusual persistency and severity—  
Recovery under central galvanization.*

CASE CLV.—Miss H., aged 16, was transferred to our care by the family physician, Dr. H. H. Gregory. The case is an example of an unusually susceptible nervous organization, and is a good illustration of the readiness with which many so-called nervous symptoms change their seat and character. The distinct and positive features that stand so boldly relieved in the progress of this particular case, may serve to explain the more subtle and less marked changes of symptoms that so often occur in certain nervous diatheses, only to perplex and to set at naught the resources of therapeutics. The patient was a lively, impressible girl, prone to physical indiscretions, and careless of consequences. She had suffered for a number of years from frequent and unusually severe attacks of sick-headache, but as soon as the paroxysm had passed away, she regained her usual strength and buoyancy. The sudden and unexpected death of a sister, naturally enough, stirred up her emotional nature to its depths, and together with an imprudent exposure of her person to cold and dampness, seemed to be the exciting cause of a most remarkable, persistent, and distressing cough, which, slight at first, reached its height in severity in the month of March, 1872. Amid the numberless efforts that were made by both internal medication and inhalations, but one remedy seemed to be of the slightest service. For a time the paroxysms seemed to abate somewhat under the influence of chloral, although no permanent benefit was derived from its use. When, during the latter part of July, we first saw the case, through the kindness of Dr. Gregory, the following was the prominent characteristic of her paroxysmal attacks: Every one will instantly recognize the peculiar harsh or grating sound which is so often elicited by the downward thrust of a saw that is improperly handled or insufficiently oiled. The cough of our patient exactly simulated this sound, and, when it first fell upon our ears, we supposed that some one was sawing in the adjoining room.

During a paroxysm, the expiratory efforts were just one a second in frequency, and from a dozen to sixty in number.

The violence of the attack would rack her terribly, and, when prolonged, was fol-

lowed by considerable exhaustion. The paroxysms themselves occurred so often, some twenty or twenty-five times during the twenty-four hours, that she was necessarily obliged to give up all attendance at places of public resort, and confine herself mostly at home.

On account of our absence from the city most of the month of August, the patient was not fairly submitted to our treatment until September. We then submitted her to a thorough laryngoscopic examination, and found nothing abnormal, with the exception of a slight tendency to congestion of the local chords. To dissipate any doubt in regard to the existence of pulmonary disease, the patient was thoroughly examined by Dr. Austin Flint, who pronounced the lungs to be in a healthy condition, and agreed as to the essentially nervous origin of the symptoms.

In the treatment of the case by central galvanization we were gratified to observe, after the first few tentative applications, an appreciable improvement in the character of the cough. Instead of that harsh and painful sound, resulting, as we believed, from the exceedingly tense condition of the vocal chords, the cough assumed a softer or looser character, and was much less disturbing; this we conceived depended on the decreased local spasmodic action. Freed from wearisome details, the subsequent history of the case is included in the simple statement that the patient improved from time to time, until, after two months of treatment, and the administration of some thirty-five applications, the recovery was perfect.

Two years have now elapsed since recovery, but the patient remains well.

In the case of a young girl sent to us by Dr. Leaming, there was a nervous cough that perfectly resembled the barking of a dog. Laryngoscopic examination revealed nothing to account for the strange symptom. Electrical treatment accomplished nothing.

*Hyperæsthesia of the Larynx.*—Cases of this disease have been reported by Gerhardt and Hanfield Jones. They may be either constant or intermittent. The following case is quite remarkable:

*Hyperæsthesia of larynx with nervous aphonia of one year's standing—No visible lesion, but slight tuberculous deposit on lung—Great pain from talking—No Relief under central and local galvanization.*

CASE CLVI.—Miss B—, a young lady from Chicago, was referred to us by Dr. Johnson, of that city, December 16, 1871.

The patient was of a delicate, thoroughly American type, but no more nervous than thousands of our countrywomen.

For one year she had suffered from absolute aphonia. The laryngoscopic examination of Dr. Johnson, her physician in Chicago, and of others, indicated no local lesion that could well account for her symptoms, although a slight tuberculous deposit of a passive and stationary character was detected by Dr. Clark in one lung. All the accompanying symptoms pointed to a nervous origin of her disease. The hyperæsthesia was very remarkable. The patient said the pain from whispering was so great that, "when I try to whisper I suffer terribly, become dizzy, and have pain in my ear." "I often feel," she continued, "as if every word I whispered grated on the vocal cords, and to laugh would *make the cords ache.*" Almost continually there was pain in the throat, and on this account her nights were wakeful.

The evidence was pretty clear that the nerves supplying the larynx were in a condition of great hyperæsthesia, producing a condition analogous to vaginismus.

In Chicago Dr. Johnson had used electrical treatment, with a view to excite the action of the cord, without benefit. Stable galvanization was used, mainly with the view of calming the irritability and reducing the hyperæsthesia, but without success. In about a month the patient went South for the winter, and we have not seen her since that time.

One amongst other interesting points in this case is the clinical proof afforded of the nervous connection of the vocal cords with the meatus auditorius and membrana tympani. The anatomical explanation of the phenomenon recorded here is to be found in the *direct* communication existing between the auricular nerves (first described by Arnold) and the sensitive fibres which enter so largely into the composition of the main trunk of the pneumogastriæ.

*Anæsthesia of the Larynx.*—This is an affection but rarely observed. It would be most likely to occur from injury of the pneumogastric nerves of their laryngeal branches.

It is rational to suppose that anæsthesia of the larynx might be successfully treated by electrization in its various forms, on the same principles that this morbid condition is treated in other parts of the body.

## CHAPTER XXXI.

### DISEASES OF THE EYE.

FOR two reasons the diseases of the eye are not quite as amenable to electrization as corresponding or analogous diseases in some other parts of the body.

*First.* The anatomical position of the eye is such that the current cannot be directly localized in some of its parts; and *secondly*, the application of a very strong current is sometimes contra-indicated by the sensitiveness of the conjunctiva, and the possible injury that may be done to the brain.

For these reasons paresis and paralysis of the muscles of the eye—the conditions of the organ that are most frequently treated by electricity—cannot be as successfully subjected to electro-diagnosis or therapeutics as the same conditions of many other muscles, although therapeutic results in many instances of a decided character are obtained from electrization of the paretic or paralyzed muscles.

The principal diseases of the eye for which electricity has been employed with more or less success are:

*Paralysis of the Muscles,*  
*Asthenopia,*  
*Retinal Hyperæsthesia,*  
*Amaurosis and Amblyopia,*  
*Spasm of the Lid,*

*Ptosis,*  
*Opacities of the Cornea,*  
*Photophobia,*  
*Myosis and Mydriasis,*  
*and Neuro-retinitis.*

*Electrization of the Eye.*—The electric current affects the eye both directly and through reflex action from the fifth pair, and also through the sympathetic. As has been stated, the anatomical position of the eye within its bony cavity makes it impossible to reach all its parts as directly as could be desired; while the exceeding delicacy of its structure makes it at least very difficult to make the applications immediately to the conjunctiva.

The eye may be electrized in a general way, in asthenopia, for example, by pressing one large positive electrode over the closed eye, and the other at the occiput or by the side of the head above the cheek-bone; or one of the electrodes may be held in the hand. When it is desired to produce chemical changes in the eye this stable method of

application may be used for some time. Placing the positive pole on the forehead or in the auriculo-maxillary fossa, the *superior oblique* may be excited with the negative pole on the upper and inner part of the orbit; the *inferior oblique* and *rectus internus* near the inner angle of the eye on the side of the nose; the *rectus externus* at the outer angle of the eye; the *rectus superior* at the upper part, and the *rectus inferior* at the lower part of the eyeball. Galvanization of the eye with interrupted currents to affect the muscles should usually be short, but stable or labile faradization with large electrodes may sometimes be made for a much longer time—three to ten minutes.

*Paresis (exhaustion)* or *paralysis* of the muscles of the eye may arise from cerebral lesions, or may be of a peripheral character. Locomotor ataxia is frequently preceded or accompanied by disorders of the muscles of the eye.

For the purpose of affecting the *muscles* of the eye the galvanic current is usually superior to the faradic. A small number of cells, from ten to fifteen, are usually sufficient. Galvanization of the sympathetic should also be tried in those cases that are supposed to be of cerebral origin. Short treatments, from one-quarter of a minute to one or two minutes, are preferable to longer applications. In these conditions protracted séances not unfrequently do injury.

Here, as elsewhere, the sensitiveness of the patient and the results in each case are perhaps the best guide. And yet it is always well to be cautious in the first application. In diseases of the eye, as of other parts of the body, we meet with exceptional cases that will bear and be benefited by very protracted applications of mild galvanic currents.

The unfortunate accident that happened to Duchenne—total destruction of the sight of a patient immediately after galvanization—did much for a time to retard the electro-therapeutics of the eye. The accident, however, has never been repeated, although the electro-therapeutists of the present day galvanize the eye and the brain with great freedom.

Localized *faradization* has been somewhat successful in the treatment of paralysis of the muscles of the eye in the hands of Meyer,\* Soelberg Wells,† and Althaus.‡ Althaus has succeeded with the faradic current after failure with the galvanic. The current reverser electrode is very convenient for the treatment of paralysis of the muscles of the eye.

*Prognosis in Paralysis of the Muscles of the Eye.*—The prognosis of

\* Op. cit. p. 378. † Diseases of the Eye, 1869, p. 568. ‡ Op. cit., p. 495.



paralysis of the eye that depends on cerebral lesions is usually unfavorable. Cases that arise in the early stages of disease of the brain or spinal cord, as locomotor ataxia, and early syphilitic cases, offer a good prognosis, though they are disposed to relapse.

Peripheral cases, when taken in the early stages, have a very favorable prognosis, but not so with cases that are long standing.

Benedikt, speaking of the prognosis in cases of paralysis of the eye, declares that of eight cases, from various causes, that were sent to him by Wecker, of Paris, in seven there was immediate improvement.\* The same writer states that when the absolute excursive capacity of the pupil is little altered, but double vision is present in a great part of the visual field, the prognosis is unfavorable.

In some cases improvement follows early, after one or two sittings, or during the midst of the sitting; in other cases not until ten or fifteen.

The tendency with patients and physicians is to abandon treatment in paralysis of muscles of the eye, without giving it a fair trial. They certainly demand as long treatment as analogous affections in other parts of the body.

*Paresis of the left internal rectus muscle—Immediate improvement under localized faradization.*

CASE CLVII.—Mr. M. B., with paresis of the left internal rectus muscle, was sent to us by Dr. C. R. Agnew for electrical treatment. The first symptoms of the difficulty dated some months back, just after his return from the West, where he had been subjected to unusual fatigue. A powerful current (faradic), localized as nearly as possible in the affected muscle, very markedly relieved the heaviness of the eyelid, and immediately improved the sight.

For over a month the patient had been able to read only imperfectly and with difficulty, while an hour previous to the electrical treatment it was found, on trial, at Dr. Agnew's office, that he was utterly unable to decipher newspaper print.

Immediately after one application the patient could read the fine print of the *Herald* with ease, and in a day or so a note from Dr. Agnew informed us that the vision of the patient had increased from one-tenth to one-half, and that the internal rectus had gained seventy, tested by prisms.

*Paralysis of the abducens of both eyes—Double vision ten months' standing—Possible syphilitic origin—Recovery under localized galvanization and iodide of potassium—Relapse.*

CASE CLVIII.—Mr. R., aged 46, was referred to us, May 1, 1874, by Dr. Rushmore. Patient complained of double vision—health otherwise good. Dr. R.'s diagnosis was, paralysis of abducens on both sides, and as the patient had suffered from syphilis sixteen years before, iodide of potassium was given.

\* Op. cit., p. 292.

For three months this treatment was kept up with but little improvement. We began treatment by localized galvanization, using strong interrupted currents—one pole at the external angle of the eye, and the other on the temple, or at the back of the neck and continued this treatment twice a week for one month without any improvement. About June 1 improvement began, and by June 22 the recovery was emphatic, so far as double vision was concerned; dimness of vision remained.

The patient continued the iodide of potassium at the same time with the electrical treatment, and it is clearly impossible to differentiate with certainty the effects of the two remedies; but inasmuch as the iodide of potassium had been used before, and very faithfully, without effect, it is exceedingly probable, to say the least, that the recovery was largely due to the electrical treatment. The patient subsequently relapsed.

The following are some of Benedikt's \* cases :—

“Burggraf, Johann, aged 23 (Arlt's clinique, April 22d, 1864), had been suddenly seized with double vision fourteen days previously. Paralysis of the right abducens, preceded by violent pains in the head for eight days. Recovery through local treatment in six sittings.

“Meyer, Antonia, aged 55, laborer (Arlt's clinique, Sept. 18, 1866), had suffered for three days from double vision, paresis of the right abducens. The excursion was deficient by one line. There was double vision in the larger half of the visual field. After nine sittings the excursion was normal. Double vision in the extreme portion of the visual field. Entire recovery after twenty sittings.

“Mako, Barbara, aged 24 (Arlt's clinique, Jan. 29, 1863), suffered for six weeks from complete paralysis of all the branches of the oculo-motorius. After three weeks the paralysis was removed, and the patient, although he had yet some double vision, left the hospital.

“*Isolated Mydriasis.*—Rentier, aged 40, suffered from mydriasis and paralysis of accommodation on the left side. After two local treatments the mydriasis diminished. It relapsed after a coitus, but was finally entirely healed in twelve sittings, and remained healed for several years.”

*Asthenopia.*—Asthenopia may depend on an absolute or relative deficiency of energy in the muscle of accommodation; or of the internal recti. It is accompanied by hyperæsthesia of the retina and ciliary nerves.† Of these two forms, the accommodative and muscular, the accommodative is the more frequent. The marked effects in improving the tone of exhausted muscles in other parts of the body, produced by electrization, would lead us to suppose that asthenopia might be benefited by passing either the faradic or galvanic current through the eye.

In quite a number of cases of weakness of eye with hyperæsthesia, that have not been accurately recorded, we have obtained positive and rapid results. For those very numerous cases of eyes that ache

\* Op. cit., p. 297 et seq.

† Stellwag, Treatise on the Diseases of the Eye, translated by Drs. Hackley and Roosa, p. 622.

severely if used even for a little time before breakfast, or at twilight, or in reading fine print, or doing fine needlework, or from exposure to glaring light; that perhaps are annoyed by *musca volitantes* and by neuralgic pains in or near the eye, and yet in which ophthalmoscopic examination reveals no lesion—for such cases mild labile faradization for five or ten minutes through the eye with the positive pole, either with a moistened sponge or the hand of the operator, while the negative is at the back of the neck or in the hand of the patient, is certainly a most agreeable and efficacious remedy. Stable galvanization is also useful in the same condition. Cases of this kind that are associated with general feebleness, with hysteria and dyspepsia, are sometimes much benefited by general faradization even when the eye receives no local treatment whatever. The *tired, aching eye* is both temporarily rested and relieved after each sitting, and permanently strengthened by continued treatment. In such cases electrization does for the eye what it does for the stomach, or larynx, when they are in a condition of fatigue.

*We believe that electro-therapeutics promises more for asthenopia, with hyperæsthesia of the retina, than for any other disease of the eye.*

From the known effects of electrization on neuralgic and muscular weakness of other parts of the body, it would certainly appear that asthenopia, even in its severe phases, might also be successfully treated by the same agent. The subject is worthy of the earnest attention of ophthalmologists.

*Asthenopia of two years' standing—Rapid improvement under localized faradization.*

CASE CLIX.—Mr. L., a student, aged 25, was referred to us by Dr. Loring. The patient had for two years been afflicted with exceeding weakness of sight, and for a long time was unable to read more than a minute or two without discomfort. Time and rest had afforded slight relief, so that he now found it possible to read by daylight some eight or ten minutes; by gaslight he could not read at all. A mild séance of localized faradization was essayed, with the result of markedly increasing the strength of vision. Similar applications were repeated some dozen times, with the most happy effect, and when last seen the patient was able to read an hour without serious discomfort.

A second case, sent soon after by Dr. Loring, received equal benefit.

*A case similar to the above—Improves more readily under galvanization than faradization.*

CASE CLX.—A case similar in its symptoms to the above, and of as long standing, that was sent to us by Dr. Roosa, was submitted to localized faradization, with some benefit. Localized galvanization, however, with an exceedingly feeble

current, proved of greater service, and after a month of treatment the patient was able to read ordinary print for over an hour continuously, without experiencing any discomfort.

*Asthenopia of an aggravated character and of two years' standing—Complete recovery under twelve applications of localized faradization.*

CASE CLXI.—The most satisfactory result that we have to record in the treatment of asthenopia was in the case of a lady aged 60. For two years she had observed a constantly decreasing strength of vision, associated with a local irritability, that precluded any attempt at continuous use of the eyes. Finally, so weak did the organs become that she found it utterly impossible to read or sew, or in any way concentrate her sight for a moment without suffering pain and obscuration of vision. She was treated wholly by localized faradization—the tips of the fingers alone being used as electrodes.

But about twelve applications were given, with the result of complete and permanent recovery. During the three years that have elapsed since this treatment the eyesight has remained perfectly strong.

*Amblyopia and Amaurosis.*—Amblyopia is now understood to be a disorder of vision dependent on disturbance of the circulation, while amaurosis is to be regarded as a symptom of atrophy of the optic nerve.

For some of these conditions electrization may be tried with advantage.

A strong encouragement for a faithful trial of electricity in these cases is that various degrees of impairment of vision, from complete blindness through the lower grades, have been sometimes most successfully treated by physicians and charlatans, with diverse methods of application. De Saussure cured a case of amaurosis by statical electricity. Lesueur, Magendie, and Person, successfully used faradization in the same cases.

What is now needed is a careful and persevering trial of galvanization and faradization in cases of amblyopia and amaurosis, after accurate ophthalmoscopic examination.

*Spasm of the Lid (Blepharospasm).*—For spasm of the *levator palpebræ* and *orbicularis palpebrarum*, faradization or galvanization is indicated for the same reason that it is indicated in torticollis, facial spasm, and spasm of the glottis.

The method of application is the same as that prescribed for asthenopia.

*Prognosis.*—Recent and mild cases recover rapidly. Long-standing cases are sometimes very obstinate, but even these are frequently relieved for a limited time after each sitting.

*Slight spasmodic twitchings of the lid—Recovery under faradization.*

CASE CLXII.—A lady had been troubled with an affection of the left eye that required surgical treatment; was taken with slight but disagreeable twitchings of the lid of the other eye. The twitching was so slight that it could be seen by an observer only with difficulty.

Under faradization with a mild current, the negative pole being held in the hand of the patient, and the positive being applied by gentle passes over the lid, recovery took place in a short time.

*Spasm of the orbicularis palpebrarum of long standing—Some temporary but no permanent benefit from faradization and galvanization.*

CASE CLXIII.—Rev. Mr. B. was referred to us by Dr. C. R. Agnew with severe spasms of the orbicularis palpebrarum of the right side; the general health of the patient was otherwise good. Faradization and galvanization, faithfully used for a number of sittings, in the manner described in the case preceding, were only of temporary benefit.

*Opacities of the Cornea.*—The electric currents have been employed with more or less success for opacities of the cornea for many years. Cases have been reported by Isiglio, Quadri, Willebrand, Türck, and Graefe. Recently this method has been but little employed.

The galvanic current would be more indicated than the faradic. External or internal applications may be used.

In a case of opacity of the cornea, resulting from *herpes ophthalmicus*, sent to us by Dr. Prout, there was a very decided clearing up under a protracted use of the negative pole of the galvanic current applied to the closed lid, and a part of the time directly to the conjunctiva, which had been rendered anæsthetic by the herpes.

*Opacities of the Vitreous Humor—Keratitis.*—Le Fort and Carnus report interesting and remarkable results in the treatment of opacities of the vitreous humor by the galvanic current. The applications were made with one pole over the closed eyelid, and the other in the auriculo-maxillary fossa, to affect at the same time the nutrition of the eye through the sympathetic. In some of the cases the opacity was associated with or resulted from keratitis.

*Photophobia.*—Photophobia is a symptom of so many different pathological conditions, that the cases of cure or relief obtained in it by the electric currents are of comparatively little value. It very frequently depends on the diseases of the conjunctiva and cornea. Hewson reports the cure by galvanization of thirty-two cases of photophobia dependent on scrofulous inflammation of the cornea in children. From one to three applications were sufficient.

The positive pole was applied to the face and the negative to the supra-orbital foramen.

*Ptosis.*—This affection, which consists in paralysis of the elevator of the upper lid, is to be treated like spasm of the lid, but with a stronger current.

*Ptosis following herpes—Rapid recovery under galvanization.*

CASE CLXIV.—A lady patient was referred to us, who had suffered long and severely from herpes of the head and face. This was followed by acute neuralgic pains that were most persistent and resisted all attempts at alleviation.

The galvanic current was here applied, and so successfully as in a short time to dissipate in good measure the neuralgia. The eyelid of the right side, however, was left drooping, a condition which had been present some weeks. Three applications of the faradic current to the affected part, of a strength as great as could be well borne, were repeated on several occasions and readily resulted in a complete restoration of the lost muscular power.

*Mydriasis and Myosis.*—In these conditions the electric treatment is sometimes of value, although in many cases they depend on some central difficulty that in its very nature is incurable.

The treatment consists in local galvanization and galvanization of the sympathetic.

*Neuro-retinitis.*—On the theory that neuro-retinitis may depend on some morbid condition of the sympathetic, which in its turn may be connected with various cerebral affections,\* it has been treated by galvanization of the sympathetic, and of the brain.

Indeed, from our experiments in galvanization of the sympathetic (see p. 125), it would appear that in neuro-retinitis, and, indeed, in all affections where we wish to affect the vascular condition of the retina, galvanization of the sympathetic would very properly be indicated in connection with other remedies directed to the disease. The subject is certainly worthy of investigation.

*Strabismus.*—In strabismus, dependent on merely transitory causes, faradization or galvanization may be of service; but the results yet reported are not of great importance.

That temporary relief of strabismus may be derived from faradization we demonstrated in several instances. The method of application is the same as that for paralysis of the muscles.

From among many failures in the treatment of strabismus that we find recorded in our case books, we briefly note the two following as illustrative of the benefit that occasionally accrues through electrization.

\* Benedikt, op. cit., pp. 252, 253, 254.

CASE CLXV.—A little girl, aged 8, had for two years been afflicted with strabismus divergent.

The faradic current was as nearly as possible localized in the faulty muscles, and at the same time the body of the eye was submitted to gentle treatment.

Improvement became manifest after a few applications, and in the course of two months ended in recovery.

CASE CLXVI.—In the case of a babe of 18 months, who had shown symptoms similar to the above, some three weeks previously, it required but a single application of the faradic current to dissipate the trouble.

*Cataract.*—The literature relating to the use of galvanism in the treatment of cataract is very considerable, but, at the same time, both the opinions and statements are very conflicting. Crussel, of St. Petersburg, claimed to have had successes. His method was to introduce into the lens a needle connected with the negative pole, while the positive was applied to the tongue. In this way the cataract was subjected to the three factors of mechanical disintegration by the needle, to the chemical influence of the negative pole, and “probably, also, to the macerating action of the aqueous humor penetrating the lens through the puncture made in the capsule by the needle.” Bergmann, Newmann, Mildner, Benedict, Strauch, and others, on the contrary, claim that the results are not sufficiently favorable to counterbalance the dangerous inflammation that is liable to follow.\* Rosenthal used external applications, and claimed to have cured two out of three patients whom he thus treated. Two cases of cures have been reported lately by Neftel. The cases were subsequently examined by Drs. Agnew and Knapp, who failed to find evidence of any improvement that could be attributed to electricity.

Among other diseases of the eye in which electricity may be tried experimentally, with the hope of greater or less success, are *anæsthesia optica* and *nystagmus*.

\* For the literature of the subject consult Canstatt's “Jahresbericht” for 1841-45, also Schmidt's Jahrbücher for 1841-42, quoted from Evetzky's article “On the Nature of Cataract,” etc., N. Y. Med. Journal, July, 1880, to which we are indebted.

## CHAPTER XXXII.

### DISEASES OF THE EAR.

THE diseases of the ear are less amenable to treatment by electricity than analogous diseases in most other parts of the body. By its anatomical position the internal ear is even more inaccessible than the eye; and even the parts which can be brought more directly under the influence of electrization, as the middle ear, the *membrana tympani*, and external auditory canal, can bear only feeble currents. Hence it is that there is no branch of electro-therapeutics where there has been such general disappointment both among aurists and electro-therapeutists as in diseases of the ear.

The morbid conditions of the ear for which electrization has been found of some service are subacute and chronic *inflammation of the drum and middle ear*, *nervous deafness*, and *tinnitus aurium*.

Experiments on the ear were made quite early in the history of electro-therapeutics.

Brenner\* gives the following bibliography of this department in the early part of the present century:—

AUGUSTIN—*Versuch einer Geschichte der galvanischen Elektrizität und ihrer medicinischen Anwendung*, Berlin, 1801 (this work contains a quantitative distinction in the working of both poles on the nerves of hearing); also, *Von Galvanismus und dessen Anwendung*, 1801, by the same author.—MERZDORFF—(*Behandlung des Ohrensausens durch den Galvanischen Strom*,) bei GRAPENGIESSER, 1801, pp. 131 and 132.—FLIES—(*Galvano-therapeutische Versuche*,) Ebendas., 1801, pp. 241, 252.—STELLWAG—*Ueber Galvanismus*, Hamburg, 1802 (this work contains cures of deafness).—STRUWE—*System der Medicinischen Elektrizität mit Rücksicht auf den Galvanismus*, 1802.—WOLKE—*Nachricht von den zu Jever durch die Galvani-Voltaische Gehörgebekunst beglückten Taubstummen*, etc. Osnabrück, 1802.—MARTENS' *Therapeutische Anwendung des Galvanismus*. 1803.

It was natural that attempts to cure diseases of the ear should be made thus early in the history of electro-therapeutics, because at that time there was scarcely any other method of treatment.

\* Untersuchungen und Beobachtungen auf dem Gebiete der Electrotherapie, 1 Band, 1 Abth., 1868, p. 40.



There are two general methods of electrizing the ear—*internal* and *external*.

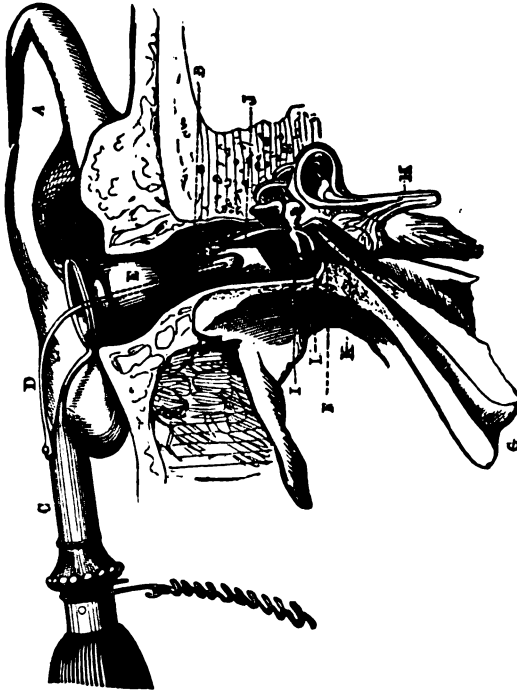

FIG. 132.

*Internal method of electrization of the ear* (Duchenne). A, auricle; B, external auditory canal; C, handle of electrode; D, flexible wire; E, rubber speculum; F, ossicula in middle ear; G, mouth of tube; H, auditory nerve in inner ear; I, inferior half membrana tympani; J, external muscle of hammer; K, internal muscle of hammer.

The flexible wire can be pressed in toward the drum and then allowed to spring back. The external auditory canal is very sensitive, and only mild currents, or currents quickly interrupted, will be borne. The other electrode may be placed in the hand of the opposite side, or at the mouth of the Eustachian tube, by means of a metallic-pointed insulated catheter. It is an advantage before making the application to partly fill, or at least to moisten, the ear with warm salt water, since thereby the conduction is much increased. The water should be warm, because cold water is not well borne in the ear.

*External Method.*—The best external method of electrizing the ear is to *press the electrode firmly on the tragus*, the other electrode being held as before, in the hand of the opposite side. The ear should be filled with warm salt water, although this is not necessary.

We have used this method for several years with both the faradic and galvanic currents, and prefer it for all cases *except when it is desired to act directly on the inflamed surfaces of the drum, or middle ear*. It is far less painful and more satisfactory than the internal method. It may be used on the most sensitive children, who would rebel against the internal method, however skilfully performed.

The sitting should not usually be more than five or ten minutes, and in some cases much shorter applications should be used, especially when the galvanic current is used.

The electro-physiology of the ear has already been described in the section on Electro-Physiology.

*Electro-Diagnosis.*—The electro-diagnosis of diseases of the ear has been specially studied by Brenner.

The leading idea of this observer\* is *that the reaction of the auditory nerve to the galvanic current is variously changed by pathological conditions*.

The normal formula has already been given. (See Electro-Physiology, p. 132).

The difficulties in the practical application of this method of electro-diagnosis are very great. The normal formula can be obtained only in a certain proportion of cases, and then oftentimes by painful currents. Even when we obtain apparent deviations from the normal formula, we are not always sure just what such deviation indicates, either in special pathology or in therapeutics.

*Changes in the Reaction of the Auditory Nerve in Pathological Cases.*—In pathological cases the normal formula may undergo various changes.

These changes in the reactions that appear in diseases of the ear may be embraced under the following heads: †

1. *Hyperæsthesia of the nerve*, so that it reacts to a milder current than normal, or reacts longer or more powerfully. This may be either

\* Zur Elektrophysiologie und Elektropathologie des Nervus acusticus. Petersburg Med. Zeitschr., Bd. 4, p. 286. 1863. Also, Weitere Mittheilungen zur Elektrotratrik. Petersburger Med. Zeitschr., Bd. 5, p. 35, 1863. And more recently in his published work, Untersuchungen und Beobachtungen auf dem Gebiete der Elektrotherapie. Leipzig, 1868 and 1869.

† Brenner, op. cit., Band i., p. 181 et seq.

simple or complicated with qualitative change in the formula, or with paradoxical formula in the ear not experimented on, or with morbid subjective sensations of hearing.

2. *Change in the formula of reaction without hyperæsthesia.* These changes are either in inversion of the normal formula, or deviations of various kinds.

3. *Torpor of the nerve (anæsthesia)*, so that it does not react, or only to a stronger current than normal.

*Illustrative Pathological Cases.*—Brenner gives the following illustration of hyperæsthesia in a case of chronic catarrh of the middle ear, on both sides, with difficulty of hearing, much *tinnitus*.

The reaction was as follows :

XX 90 Ka.S.K'.  
 Ka.D.K. ∞  
 Ka.O.—  
 A.S.—  
 A.D.—  
 A.O.k.>

In another case, where there was great difficulty of hearing, with tinnitus, that had existed for three years, and demonstrable anatomical changes, but in which a central disease was suspected, the reaction was as follows :\*

XX 50 Ka.S.K'.  
 Ka.D.K. ∞  
 Ka.O.—  
 A.S.—  
 A.D.—  
 A.O.k.>

Other cases, illustrative of changes of various kinds, we give below :—

<p><i>Qualitative change.</i>—A laborer, 30 years old; intelligent; deafness and tinnitus on both sides from childhood; drum cloudy and thickened.</p> <p>X 100 Ka.S.K'.          Ka.D.K. ∞          Ka.O.—Rattling.          A.S. "          A.D. " ∞          A.O.K.&gt;</p>	<p><i>Hyperæsthesia with inversion of the normal formula.</i>†—A lady of 60; absolute deafness in left ear; drum depressed, thickened and opaque.</p> <p>6 El. Ka.—          Ka.D.—          Ka.O.Pf. &gt;          An.S.Pf.          An.D.Pf. ∞          An.O.—</p>	<p>Hyperæsthesia with paradoxical sensations in ear not treated.‡</p> <p>Ear treated. Ear not treated.</p> <p>XX 100 Ka.S.K'.          Ka.D.K. ∞          Ka.O.— K.&gt;          A.S. K'.          A.D. k.&gt;          A.O.K'.&gt; —</p>
--	--	---

\* Op. cit., pp. 90, 191.

† Erb in Archiv Ophth. and Otol., vol. I, No. 1, p. 272.

‡ Brenner, op. cit., Band i., p. 205.

*Illustrative and typical case of inversion of the normal formula.\**—An officer, 26 years old; from his childhood completely deaf in left ear; no tinnitus; no demonstrable change in drum; only a pale color; right ear normal.

Electric examination of right (healthy) ear gives this <i>normal</i> formula.	Electric examination of left (diseased) ear gives the <i>inverted</i> formula.
IX Ka.S.K'.	IX Ka.S. —
Ka.D.k. >	Ka.D. —
Ka.O. —	Ka.O.K.
A.S. —	A.S.K'.
A.D. —	A.D.K. >
A.O.k.	A.O. —

*Modification of the normal formula without hyperaesthesia.*—A woman, 45 years; old difficulty of hearing in both ears; no tinnitus; some dulness of the drums.

RIGHT EAR:—

XX 500 Ka.S.—“Chirping.”

Ka.D. “short

Ka.O.

A.S. —Roaring.

A.D. “short.

A.O. —Indefinite sounds.

Left ear gave same formula, except that Ka.O. gave a short and slight roaring.

The above case of the officer Brenner regards as of a special nature. The patient was examined by a number of aurists, and the inversion of the normal formula in the diseased ear was decided.

The following experiments were made by one of the authors of this work on himself. The right ear, on which the experiment was made, has for twenty-five years been affected with chronic inflammation of the middle ear. The drum is cloudy, the tube pervious, and the hearing distant; at times he had been troubled with tinnitus, but not at the time of the experiment. The objective examination of the ear was made by Dr. D. B. St. John Roosa. The experiments are given in detail, because they illustrate a number of the peculiarities in regard to the galvanic reaction of diseased ears, and the difficulties and complications that attend the investigation.

The *internal* method was used:

10 Stöhrer's El. Ka.S.—No reaction.

Ka.D.—Some rumbling, made evidently by pressure of electrode. †

Ka.O.

An.S.—No reaction.

An.D.—“ “

An.O.—“ “

12 El. Ka.S.—No reaction.

Ka.D.—“ “

Ka.O.—“ “

An.S.—“ “

An.D.—“ “

An.O.—“ “

Feeble flashes of light were observed. The rumbling of a distant carriage for a moment was mistaken for the cathode closing reaction.

\* Brenner, l. c., p. 219.

† In order to prevent deception on this point, the finger was pressed on the tragus, and found to produce the same apparent sensation of rumbling. The apparatus

16 El., Ka S.—No reaction.

Ka. D.—Hissing in the other ear; (paradoxical reaction).

Ka. O.—Same for a moment.

An. S.—Hissing.

An. D.—Same. >

An. O.—No reaction, but hissing in other ear.

Stronger flashes of light; dizziness; subjective sounds in ears for some minutes after treatment.

20 El. Ka. S.—Slight roaring.

Ka. O. >

Ka. O.—No reaction.

An. S.—Loud hissing (seething).

An. D.—Same. >

An. O.—No reaction.

Considerable pain in ear; much stronger flashes and dizziness; metallic taste; burning in wrist of the hand holding cathode.

The rheostate was now brought into use.

24 El. K. S.—Low rumbling and hissing in other ear; very great pain; perspiration on forehead, and muscular contractions.

Ka. D.—Same. ∞

Rheostate—100—Same roaring.

200— “ “

300—Less “

400— “ “

500— “ “ less pain.

Rheostate—600—Same roaring.

700— “ “

800— “ “

900— “ “ still pain.

1,000—Much less roaring, and hissing in other ear much less.

Ka. O.—No reaction.

The anode reaction with the resistances of the rheostate was as follows:

An. S.—Very loud hissing.

An. D. ∞ and flow of saliva.

Rheostate—100—Very loud hissing.

200— “ “ “

300— “ “ “

400—Loud “

500— “ “

600—Less “

700— “ “

800— “ “

900— “ “

1,000—Much less “

Concerning the above case it may be remarked :

1. The deviation from the normal formula was unmistakable. The anode reaction was very decided, there was no possibility of a mistake. The chief difficulty was with the cathode. A low rumbling or roaring was all the reaction that could be obtained with Ka. S. or Ka. D. and that only when many elements were used.

2. The accompanying phenomena—dizziness, pain, contractions of the facial muscles, metallic taste, flow of saliva, perspiration on forehead, burning and contraction of the muscles of the hand holding the electrode—were present, but did not interfere with the observation of the reaction of the nerve. It is just, however, to remark that this in-

used in this experiment had no current reverser, consequently it was necessary to continually move the electrode to and from the tragus.

dividual has been accustomed for many years to experiment on himself with electricity, and therefore would be little liable to be annoyed or distracted by their incidental phenomena ; yet even he was deceived momentarily by the rumbling of a distant wagon. Constriction of the throat, of which some complain, was not experienced.

The following pathological case is of double interest, since benefit to the hearing seemed to result immediately after the galvanic examination.

CASE CLXVII.—G. K. B., aged 18, had from his early boyhood suffered from chronic ulceration of the membrana tympani with discharge. In the left ear the drum had disappeared. The watch could be heard only on pressure. There was no tinnitus. The Eustachian tube was pervious.

Three years before the right ear had been similarly affected, and had entirely recovered under the influence of treatment, so that the discharge ceased and the hearing was normal. At that time Dr. St. John Roosa saw the case in consultation and confirmed the diagnosis.

August, 1870. The patient again consulted us for his right ear, which we found in the condition described, and which was similar to that in which we had found it three years before. At this time we decided to test the galvanic reaction, which we were able to do without difficulty, by the external method.

The result was as follows:

8 El :	Ka.S.	Some rumbling.
	Ka.D.	“ “
	Ka.O.	No sensation.
	An.S.	Rumbling.
	An.D.	“
	An.O.	No sensation.

With ten and twelve elements there was the same, but louder, and with eighteen elements a sound like the ringing of a large bell, reaction. When sixteen elements were used, the patient experienced a sensation of hissing with An.S. and An.D.

After various changes of the current, a less number of elements brought a decided reaction. In order to see whether the patient deceived himself, or whether the sounds were produced by the agitation of the water in the ear, we applied the electrode to the tragus, when disconnected from the battery.

Immediately after the sitting the patient said that he could hear conversation better. The week following the same experiment produced the same result. During the interval magnesia had been blown into the ear in considerable quantities, so as to interfere somewhat with the hearing power ; for that reason it was impossible to determine whether the improvement was permanent.

Dizziness in this patient was very marked and lasted by terms for several days.

*General Therapeutical Results of Electrical Treatment of Diseases of the Ear.*—In the United States, cures of deafness, without regard to the pathology on which the symptom of deafness depends, have oc-

asionally been accomplished by uneducated empirics, who have treated all forms of disease of the ear, from inspissated cerumen to disease of the auditory nerve, by some unscientific and uniform method of faradization.

Duchenne reports one case by faradization of hysterical deafness of many months' standing; one caused by quinine; one consecutive to an eruptive fever; one following measles; one of twenty years' standing. Several cases of nervous deaf-muteism were also improved.

The conclusions to which he arrived are as follows: \*

1. "That nervous hysterical deafness is generally caused by electrical excitation of the *chorda tympani* and movements of the chain of little bones."

2. "That cases of nervous deafness consecutive to eruptive and continued fevers have been cured by the same treatment, even though they have been of long standing, and, from the fact of their resistance to ordinary remedies, have appeared to be incurable."

3. "That probably the therapeutical action of the process of faradization is chiefly due to the undulations of the labyrinthine liquid produced by the movements of the chain of little bones, and consequently of the *fenestra ovali*."

4. "That electric exploration of the ear furnishes no pathognomonic sign which permits the prognosis of incurability of the deafness."

*Subacute and Chronic Inflammation of the Middle Ear.*—As far as we can judge from our own observations, old cases of chronic inflammation of the middle ear, where the hearing power is so much impaired that a watch can be heard only on pressure, offer an unfavorable prognosis.

The best results are obtained in those cases that are just passing from the subacute to the chronic stage. We are inclined to the belief that these results, when they do occur, are brought about by the *mechanical action of the faradic current, on the adhesions within the middle ear.* In some even long-standing cases of chronic inflammation of the middle ear temporary improvement of hearing immediately follows faradization or galvanization.

*Tinnitus Aurium.*—The very frequent and very distressing symptom, *tinnitus aurium*, and which accompanies so many of the morbid processes in the auditory apparatus, is not relieved by electrical treatment as uni-

\* Treatise on Diseases of the Ear. Translated and edited by Dr. B. St. John Roosa. Second American edition, 1869, pp. 1,013, 1,030.

formly as *à priori* reasons would lead us to expect. The capriciousness and uncertainty of the results in such cases are partly to be explained by the fact that *tinnitus aurium* is a symptom of such diverse and sometimes undiscoverable pathological conditions. Local galvanization by the external method, or galvanization of the sympathetic, sometimes avail for the temporary relief of this affection, and in some cases a more or less permanent cure is obtained.

Galvanization of the cervical sympathetic affects the ear just as it affects the retina, through modification of the circulation in the brain. Dr. Rumbold, of St. Louis, reports two cases of *tinnitus aurium*, in which local galvanization was of great service.\*

With reference to the therapeutical value of the galvanic current, especially in the treatment of diseases of the ear, Brenner † and Hagen ‡ substantially agree to the following propositions :

1. The galvanic current is indicated not only for those cases where no morbid changes can be diagnosticated, but also in all cases, however complicated, in which the abnormal reaction to the current shows that the nerve participates in the disease.

2. The galvanic treatment may aid in the absorption of morbid deposits.

From our survey of the literature of the subject, and from our own comparative observations, we are justified in these two conclusions :

*First.* The galvanic current is on the whole of greater service, and is of greater promise in the electro-therapeutics of the ear than the faradic.

*Second.* The results obtained in the electric examinations are not uniform or always reliable guides to the special method of treatment that it is best to adopt.

Reasoning *à priori*, it would be inferred that the reaction of *hyperæsthesia* would call for treatment by the *anode*, and the reaction of *torpor* (anæsthesia) for treatment by the *cathode*; but experience shows that there is no uniformity to this law.

Moos, § in the remarkable case to be hereafter cited, found that the cathode at one time exercised a temporarily beneficial influence on the subjective symptoms, which usually disappeared only under the anode.

Erb || also, in case of "*simple hyperæsthesia* of the right auditory

\* Archives of Electrology and Neurology, May, 1874.

† Op. cit., Band i., p. 262.

‡ Praktische Beiträge zur Ohrenheilkunde, Leipzig, 1866, p. 29.

§ Archives Ophthal. and Otol., vol. i., No. 2, p. 488.

|| Archives Ophthal. and Otol., vol. i., No. 1, p. 28.



nerve," with "*inversion of the normal formula,*" found that the tinnitus was quieted by the closing of the cathode (Ka.S.) and not by the closing of the anode, as would have been expected.

Still further, it is not demonstrated that in many of the cases of hyperæsthesia that were successfully treated by the anode, or of torpor (anæsthesia) that were successfully treated by the cathode, the results might have been equally or more successful if the poles had been reversed. The conclusion is, therefore, that while the general law laid down on page 281, that *the positive pole is on the whole the more calming and the negative the more irritating,* applies to the auditory nerve as to other parts of the body, yet it is always liable to many real or apparent exceptions, and in the present state of our knowledge the rule can never be made an absolute or uniform guide in the electro-therapeutics of the ear.

Brenner \* details eleven cases of diseases of the ear treated by the galvanic current.

In one case of thickening of the drum, the current caused absorption.

In one case of hyperæsthesia, with tinnitus aurium and anatomical changes in the middle ear, the tinnitus was rapidly cured.

In one case of hyperæsthesia, after the use of quinine there was recovery.

In one case of hyperæsthesia, with tinnitus aurium and catarrh of the middle ear, the tinnitus was cured.

In one case of obstinate subjective symptoms of various kinds there was improvement under great difficulties of application.

In one case of noises in the head and ears, of ten years' standing, with important anatomical changes in the ear, there was improvement.

Of deafness, two cases were improved, one was much improved, and one was cured. The case which recovered was one of facial paralysis, with anomalous reaction of the auditory nerves.

In all the cases there were anatomical changes.

In some cases the treatment was quite persistent.

*Hysterical Deafness.*—When deafness depends on simple hysteria the results of electrical treatment may be very brilliant.

Dr. Moos, of Heidelberg, has published a case of recovery from deafness under the influence of the galvanic current, which is the most remarkable of any which have been scientifically reported.

\* Op. cit. Band i., 2 Abth., p. 233 et seq. Brenner also mentions the fact that he failed in seventeen cases of tinnitus. Loc. cit., p. 235.

CASE CLXVIII.—The patient, a lady of nineteen, after an attack of acute articular rheumatism (Feb. 9, 1869), was taken with symptoms of *acute intercranial disease of an hysterical character*. She became completely deaf for noises, musical notes, and speech, and for several weeks it became necessary to communicate with the patient by writing. This deafness was preceded by *abnormal sensitiveness of the ear, and distressing acuteness of hearing*. Two weeks afterwards, the ninth week of her sickness, the sensitiveness had diminished, and her deafness was absolute. In the eleventh and twelfth weeks of the disease, she began to suffer from *hysteria or epileptic attacks*, lasting from a half to one and a half hours, from one to three times a day. These attacks were accompanied by loss of consciousness, tetanus, clonic cramps, and pains in the back and abdomen. There was also *unilateral hyperæsthesia* of the scalp and face.

These symptoms were variously treated by the galvanic current. The patient was treated with the galvanic current; at first daily, from May 10th to July 27th.

At first there was, as has been stated, a feeble reaction to the current. This was followed, in a few days, by *simple hyperæsthesia*, combined with a *paradoxical reaction* in the ear not treated, and lastly *hyperæsthesia with qualitative change*. When the cure was complete the normal formula of Brenner appeared.

On the eleventh day of the treatment the patient heard her own voice in the left ear, *immediately after the galvanic treatment*. Noises in the ear appeared which were treated by the anode. On the 18th and 24th of June, conductivity of the 'ones was noticed for the first time. July 12th, two months from the beginning of the treatment, the patient could hear the watch on the right side 10 feet, on the left 9 feet. The treatment now caused dizziness, which made it necessary to give longer intervals during the séances, and it was found necessary to use very weak currents. The patient was now sent to Black Forest, where in six weeks she fully recovered.

On the 29th of April, Dr. Moos, an experienced aurist, who had once before examined the patient, came to the conclusion that there was *perfect paralysis of both auditory nerves*. The *electric examination*, made on the 9th and 10th of May, gave the following result:—

RIGHT EAR. 10 El. 900 cR\* K.S. —Lively whirring sound.  
 K.D. —Same gradually disappearing.  
 K.O. —No result.  
 An.S.— “ “  
 An.D.— “ “  
 An.O.— “ “

LEFT EAR. 10 El. 400 cR K.S. —Scratching of a violin.  
 K.D. —The same, lasting a short time.  
 K.O. —None.  
 An.S.— “  
 An.D.— “  
 An.O.— “

The ears were differently affected. On the right side there was “paralysis of the auditory nerve, paralysis of the sense of touch, as well as paralysis of the trophic nerve, decubitus of the right concha.” On the left side there was “paralysis of the nerve of hearing, long-continued hyperæsthesia of the nerves of touch.”

\* Resistances of the rheostate.

Concerning this case we may remark :—

1. It was unquestionably a case of *hysteria*, of which the rheumatic affection was the exciting cause. Very likely some of the cures of deafness obtained, now and then, by electrization, are of a similar character.

2. Although the element of time should not be ignored, yet the recovery was mainly due to the electrical treatment. This is proved by the *immediateness and rapidity* of the results.

3. The case establishes, so far as a single case can, the substantial correctness of the main propositions of Brenner.

4. It is not demonstrated that the *exclusive* use of either pole was necessary to obtain the result, and it is entirely probable that the faradic current might have been of more or less service.

*Deafness following Cerebro-Spinal Fever.*—Our own experiments in the electrical treatment of deafness, following cerebro-spinal fever, have been entirely unsatisfactory.

Moos\* relates a case of cerebro-spinal meningitis that was followed by complete deafness, that gradually improved so that he could hear one or two feet. The patient was troubled with tinnitus aurium and also with headache and vertigo. With the right ear he heard nothing; with the left ear could hear the voice two feet. Temporarily the anode produced a diminution of the subjective noises. After twenty-two sittings the hearing power was raised to eighteen paces; the noises and giddiness were much diminished.

*Chronic Suppuration of the Middle Ear.*—We have experimented somewhat in the treatment of chronic suppuration of the middle ear by the local use of the galvanic current. The experiments were made both in private practice and at the Brooklyn Eye and Ear Hospital in connection with Drs. Matthewson, Newton, and Prout. The theory on which the experiments were based was that ulcerous conditions in the ear might be treated electrically just like similar conditions in other parts. Ulcers on the mucous membrane do not yield as readily to electrical treatment as ulcers on the surface of the body, and do not bear electricity as well; they are, however, somewhat susceptible of electrical treatment, as is shown by experiments in chronic urethritis and granular lids.

The method of treatment adopted in these experiments was to insert an electrode with a long narrow extremity, covered with a little cotton, into the auditory canal, through a rubber speculum; the canal being filled with tepid water. The electrode is usually connected with the *negative*

\* Archives of Ophthalmology and Otology, vol. ii., No. 1., p. 332.

pole of the galvanic current, though sometimes with the positive pole. The circuit is completed by the hand of the patient holding a sponge-electrode or resting on a stationary electrode. Only very weak currents and very short applications are borne, and it is almost indispensable to have some kind of rheostate, so that the current may be gradually shut on or off.

Under this treatment the character of the discharge changes, and in some cases the recovery was certainly more rapid and satisfactory than it would have been without it.\*

\* Vide Dr. Roosa, *Treatise on Diseases of the Ear*, p. 377.

## CHAPTER XXXIII.

### MIDWIFERY.

THE use of electricity in midwifery was first recommended by Bertholon and Herder (1803). Kilian afterwards used "galvanic obstetrical forceps," made of two metals.\* Faradic currents were first used for bringing on labor-pains by Hœniger, Zyly, and Jacoby, of Neustadt, in 1844. Since that time the same agent has been used for this purpose by Frank, Dempsey, Barnes, Mackenzie, Tyler Smith, Radford, and others.

The indication for the use of the current in midwifery is declared to be an adynamic condition of the uterus, when other conditions are favorable for or necessitate immediate delivery. Dempsey records a case where, after ergot in large doses had failed, faradization for forty minutes produced uterine contractions that resulted in the delivery of the child.

Frank reports a case of miscarriage, from a fall, in which faradization produced contractions of the uterus, and stopped the very profuse hemorrhage. Mackenzie succeeded in stopping the hemorrhage in two cases of placenta prævia. In one case the current was applied for six, and in the other for three hours.†

These observers claim that electricity acts more quickly, more uniformly, and with less injurious effects than ergot.‡

Both M. De Saint Germain and Tripier are highly in favor of faradization in the last stages of delivery. When the labor has fairly begun, the pains coming on at intervals of about a quarter of an hour, Tripier faradizes the lumbar region.

Uterine contractions soon follow and occur more frequently, while the dilatation of the neck takes place rapidly. In cases of confinement M. Tripier always faradizes the lumbar region by means of two electrodes, and sometimes he applies one pole directly to the uterus. According

\* Meyer, *op. cit.*, p. 452.

† Quoted by Meyer, *op. cit.*, p. 452.

‡ Simpson and Scanzoni, on the other hand, deny the utility of electricity in midwifery.

to his account the placenta is expelled immediately after the fœtus, and although it was evident that the child felt the current, not the slightest injury has ever been inflicted.\* During the last two or three years there has been a revival of interest in the use of faradization in midwifery. Quite a number of observers in different countries have reported good results.

Dr. A. Murray, of this city, informs us that he has treated eighty-two cases of *inertia uteri*, in second stage of labor, by external faradization, and always with good results.

He states that it acts much more speedily than ergot. His method is to place one pole on the sacrum and the other over the abdomen. The applications are continued for from eight to ten minutes.

*Post-Partum Hemorrhage.*—Faradization has also been used with good effect in post-partum hemorrhage. It rapidly produces contraction of the uterus, and thus may save the life of a patient.

It is to be applied the same way as before delivery.

Some obstetricians always have a faradic apparatus on hand, in case of parturition.

*Diseases of the Mammary Gland—Deficient Lacteal Secretion.*—Secretion of milk may be increased by electrization. Two methods of faradization have been proposed, one by means of moist electrodes on the gland, the other by dry electrodes, with a view to excite the secretion of the gland by reflex action.

Successful cases have been reported by Aubert and Becquerel.† Aubert cured one of his cases by dry, the other by moist electrodes. In the first case the patient had no milk three weeks after parturition. After a delay of seven months the treatment was applied. The third application brought on a milk-fever; after the fifth, milk appeared. In the other case the mother was attacked by pneumonia 11½ months after confinement. As a consequence the lacteal secretion ceased. Four faradizations with moist electrodes filled the breasts.

In Becquerel's case recovery was obtained by three applications. Similar results have been obtained by other observers.

Dr. Skinner, of Liverpool (quoted by Althaus), reports a case of a lady who, while nursing her fifth child, suffered complete suppression of the lacteal secretion, which the Doctor attributed to the tincture of iron she was taking. He applied the current (probably the faradic, which, on account of its greater mechanical effects, would be more indicated in such cases) to the left breast. The patient felt a rush of milk to the breast, and in a few hours a full supply appeared.

\* Journal de Médecine.

† Quoted by Meyer, op. cit., pp. 451 and 452.

The right breast had not been used for some time, on account of a previous abscess. As a new experiment, the Doctor made two applications of five minutes each to this breast, and brought on as much milk as in the other.

*Permanent increase in the lacteal secretion under general and localised faradization.*

CASE CLXIX.—Mrs. —, who was nursing her second child, submitted to faradization for the relief of nervous prostration and insomnia

The flow of milk was scanty; quite insufficient for the proper nourishment of the child. Under the influence of general faradization the patient soon stated that she *thought* her milk was somewhat more abundant, and in subsequent séances we invariably ended by localizing the current in both breasts. These attempts resulted in such a decided increase in the amount of milk secreted, that the infant found sufficient nourishment from the breast without resorting to artificial food.

It is worthy of comment, that the left breast, which was almost dry at the beginning of treatment, finally secreted more abundantly than the right.

Dr. A. Murray informs us that he has tried faradization as a galactagogue in thirty-seven cases. He found it efficacious in about two-thirds of the cases.

*Sore Nipples.*—Sore nipples, like ulcers and fistulæ in general, may be treated electrically by either current, but the galvanic is preferable.

Different forms of galvanic nipple-shields have been devised. These act like the electric disks, and other body batteries.

Dr. A. Murray, of this city, has devised a galvanic nipple-shield, which he finds very valuable. It is composed of silver and zinc. It is of the shape of a percussion cap, and the size of a small thimble. This shield is kept *in situ* by strips of adhesive plaster. The milk trickling down the breast may offer sufficient moisture to excite galvanic action; or a small piece of moistened lint may be interposed between the nipple and the shield. Dr. Murray claims that when this shield is worn for several hours, the excoriations rapidly heal.

He also uses this shield as a prophylactic, and for this purpose recommends it to be worn two or three hours daily for two weeks or so before confinement.

Rohland, of this city, has devised a galvanic nipple-shield of a different construction.

*Extra-Uterine Pregnancy.*—In the first case of extra-uterine pregnancy which it was the fortune of Dr. Rockwell to treat, he was asked by Dr. T. G. Thomas, one of the consulting physicians, whether it was possible to readily destroy the life of the fœtus by the electric current. He replied that it could undoubtedly be done, but the important question, it seemed to him, was whether it could be accomplished without



FIG. 133.

Murray's Galvanic Nipple-shield.

injury to the mother. This question was answered in the affirmative by the results that followed. The case was one of tubo-interstitial pregnancy, at the third month, and terminated favorably by the expulsion of the foetus and placenta through the uterus. The history of this interesting and remarkable case was carefully written out by the attending physician, Dr. Charles McBurney, and published in the *New York Medical Journal*, vol. xxii., No. 3. At the same time Dr. Thomas took full notes of the case also, and as they fully substantiate the diagnosis as first made by Dr. McBurney, and which was questioned by some journals after the appearance of his article, we are glad, with Dr. Thomas' permission, to give them as follows :

*Case of tubo-interstitial pregnancy terminating favorably by expulsion of fetus and placenta through the uterus.*

CASE CLXX.—On the second of January, 1878, I was requested by Dr. Charles McBurney to see with him Mrs. A—, a primipara, aged 21 years, who had been married on the 11th of October, 1877, and had been all her life in perfect health. She had menstruated for the last time in October, from the 1st to the 5th, and at the time of her marriage had been well for six days. Subsequent to marriage she had not menstruated, but at irregular periods, for one, two, or three days, she had had slight sanguineous discharges. In the latter part of October the gastric symptoms of pregnancy had developed themselves, and as time passed on the mammary symptoms added themselves to these. Within a month before I saw her Mrs. A.'s friends as well as her physician began to notice that she looked badly, and this fact, together with the symptoms which I have mentioned, induced Dr. McBurney to advise that a thorough physical investigation should be made.

Upon examining by touch he discovered to the left of the uterus a cyst which filled the iliac fossa and pressed the uterus over to the right side of the pelvis. It was under these circumstances that he requested me to see Mrs. A. with him. Upon passing the left index finger up the vagina I discovered an elastic and sensitive cyst to the left of the pelvis, filling the iliac fossa of that side completely. Placing the palm of the right hand over the abdomen externally and practicing enjoined manipulation, a distinct rounded mass could be felt, which was quite sensitive to pressure and which yielded very clearly the sensation of fluctuation. This was very closely connected with the uterus, which could be distinctly mapped out lying along side of and in immediate contact with it. The uterus was smaller than this mass, and although increased in size, was not so large as it should have been at or near the third month of utero-gestation. Conjoined manipulation being practised with one finger in the rectum, under the extra-uterine mass, the points which I have detailed could be made out with still greater certainty, and I even thought that I got the evidence of ballottement, though of this I was not certain.

I arrived very positively at the diagnosis of extra-uterine pregnancy, as Dr. McBurney had done, and at my suggestion Dr. T. A. Emmet was requested to examine our patient later in the day.

It was agreed that Dr. Emmet should see her alone, and that no intimation should be made to him of the opinion at which we had arrived. He did so, and at once and



very positively agreed with us in diagnosis. The abdominal walls of our patient were very thin, and she was so perfectly manageable and so desirous of aiding us to the extent of her power in arriving at a correct conclusion, that the shape of the uterus and of the mass which existed in contact with it could be mapped out with the most complete certainty. The only possible error, it seemed to me, which could affect the diagnosis was this: there might exist a bi-cornate uterus and the left horn might be the habitat of the foetus. To clear up this doubt and to make the size and position of the uterus still more certain, I met Drs. Emmet and McBurney on the next day and exposing the cervix uteri with a Sims' speculum cautiously passed the uterine sound. It was deflected decidedly to the right and passed in for a distance of between three and four inches. I turned it to the left and endeavored very gently and cautiously to penetrate the mass in the left iliac fossa, but it was impossible to do so. Drs. Emmet and McBurney then used the sound so as to satisfy themselves thoroughly as to the depth and position of the uterus and its relation to the cyst on the left of it.

The impression left upon our minds upon these points is best represented by the following sketch,



FIG. 134.

The extra-uterine mass was very slightly movable, and it differed from cases of tubal pregnancy, which I have had the opportunity of examining, in the fact that it seemed to be more intimately connected with the uterus itself. Dr. Emmet thought that by conjoined manipulation he succeeded in getting ballottement. I was doubtful whether I got it, and I was inclined to attribute the obscurity as to this point and the dense and rather nodular feel of the lower portion of the mass to the fact that the placenta intervened between the finger and the foetus.

Upon one point connected with the use of the sound I am entirely positive, and upon this I desire especially to fix attention. I used the instrument so as certainly to have broken the foetal envelopes and allowed the escape of the liquor amnii had the gestation been uterine. The uterus was certainly empty.

The condition of affairs was now fully explained to the relatives of the patient, who left the conduct of the case unreservedly to our discretion.

The prognosis of this case was at this period by no means so grave as it sometimes is in cases of a somewhat similar character, where, as, for example, in one published by myself about three years ago, abundant evidences exist that rupture is imminent. In some cases it is certain, and in all it is highly probable, that rupture generally

occurs in the Fallopian tube in tubal pregnancy from contraction of this distended muscular canal, the walls of which are composed of tissue identical in nature with that which forms the uterus. The tube develops and grows as the uterus does in normal pregnancy in an effort to meet the requirements of the growing foetal mass. Arrived at a certain period of distention, the tube, acting as a vicarious uterus, endeavors to rid itself of its contents, and after greater or less effort, being resisted by the constricted extremities which separate it from the uterus, on the one hand, and the peritoneal cavity on the other, ruptures in its attempts to accomplish the result. That a blow, fall, or effort of the abdominal muscles, or that mere hydrostatic pressure exerted by the accumulation of liquor amnii could and sometimes does cause rupture of the foetal nest no one can doubt, but we have evidence of the fact that the tube does contract with great energy under the stimulus of distention in those clonic, intermittent, cramp-like, and agonizing efforts which often precede the fatal issue in these unfortunate cases. In the case of my own just referred to, intermittent pains over the tumor were so severe that for several weeks before removal of the foetus by vaginal section the patient had to be kept almost constantly under the profound influence of opium administered by the hypodermic syringe. That these "cramps," as the patient styled them, were really due to contraction of the tube was readily ascertained by conjoined manipulation practised during the existence of one of them, when the mass could be felt contracting, condensing, and hardening itself.

The question of treatment now came under consideration in the consultation, and three plans were fully canvassed; first, that of leaving the case to nature and awaiting events; second, the resort to removal of the foetus by elyototomy; and, third, the destruction of the life of the foetus by passing through the extra-uterine mass a strong electric current. After some discussion the last plan was agreed upon, no one advocating the first. My voice was strongly in favor of destroying the life of the embryo and leaving it intact in its envelopes, in the hope that it might become to a certain extent absorbed and then encysted. In the case already alluded to, in which I removed the foetus by elyototomy, the urgency was so great from distention and contraction of the tube that I did not venture to resort to any means which involved delay or might excite muscular spasm. In that, too, the vaginal exposure of the foetal ball was much more superficial and easily attainable than in this, in which, as I have said, I had reason to fear that the placenta intervened between the foetal body and the vaginal wall.

On January 3d, at 2 p.m., Dr. Rockwell met Drs. Emmet, McBurney, and myself, bringing with him a galvanic battery of thirty-six-cell power, and we proceeded to pass the interrupted current through the mass for the destruction of foetal life.

The battery being ready, I passed through the rectum a sponge electrode mounted upon an insulated handle, and placed it just under the foetal ball. Then placing a broad, flat sponge electrode over the abdominal face of the mass, I pressed it down with the palm of the right hand, the patient lying upon the back, and a gentle current was passed. The patient becoming soon accustomed to this, Dr. Rockwell gradually increased it, and stopped the application at the end of five minutes.

On the next morning (January 4th), at 9½ A.M., the current was again passed with a force of twenty-three cells for three and a half minutes, and an appointment made for half past nine the next morning.

After the first current slight painful contractions were excited in the foetal envelope and some tenderness was developed in all the abdominal muscles, but neither pulse

nor temperature were affected. After the second, decided and very painful contractions were excited, so that opium had to be freely used to quiet suffering. The pulse gradually rose to 112 to the minute, and the temperature to  $101\frac{1}{4}^{\circ}$ . The whole abdomen was tender to pressure, but none of the symptoms were of such character or magnitude as to create apprehensions of inflammatory trouble. A discharge of blood from the uterus now established itself, and continued to the end of the case.

On the evening of this day it was felt that the death of the foetus was in all probability accomplished.

On the next day (January 5th), at 9 A.M., I met Drs. Emmet and McBurney. We found things in accordance with the report of yesterday, and determined to await events with this preparation for the worst that could befall—everything was fully prepared in an adjoining room for the immediate performance of gastrotomy if symptoms of rupture and extension of the foetus into the peritoneal cavity showed themselves. The contractions of the tube were so strong and often repeated that we could not divert ourselves of the fear that before they could be quieted by opiates and time, a solution of continuity might occur at the point of maximum distention.

Palpation being carefully made at this time, the uterus could be distinctly felt non-contractile and quiescent in its normal position, while along side of it the larger foetal shell could be distinctly distinguished, at times as round and apparently as hard as a billiard-ball.

At 11 A.M. on this same day (January 5th) I received a note from Dr. McBurney, who now remained with the patient day and night, summoning me in haste, and saying that things had suddenly and most decidedly changed. The tumor in the left iliac fossa had greatly diminished in size, while the uterus had suddenly become greatly distended and blood was pouring away from it freely. I met him in half an hour afterward, when I discovered that this uterine tumor had likewise disappeared simultaneously with the expulsion of a foetus and a placenta of perfect character. At the time that the tumor of the iliac fossa had disappeared, the patient herself noticed the alteration in the relation of itself and the uterus, which has been mentioned above, and was struck by the sudden transference of the seat of pain. When this occurred Dr. McBurney, supposing that the uterus was distended by blood, made a vaginal examination and was surprised to find a distinct sac, like a bag of water, protruding from the os uteri externum. Anxious to be certain if this were the case, he passed a speculum and discovered that it was so. He then punctured the sac, which he found very strong and resisting, and the foetus and placenta were soon expelled.

The hemorrhage now ceased, as did likewise all pain and discomfort, and the patient did well. On the next day (January 6th) I found her feeling very well both mentally and physically. Throughout the course of the case it appeared that she had fully understood its nature and its dangers, and had calmly nerved herself to bear with fortitude whatever fate might be in store for her. A year or two before this a woman had died from this cause in a country town in which she was spending the summer holidays, and village gossips had made her familiar with the difficulty. On this visit I examined carefully the uterus and late foetal nest. The former could be distinctly mapped out and was found to be very slightly sensitive to pressure. The latter could be felt with almost equal distinctness, though now insignificant in bulk in comparison with its size of twenty-four hours ago, and to the touch it was exquis-

itely sensitive. The uterus, now no longer pressed into right latero-version by an obtruding mass upon its left, had resumed its normal position in the pelvis. Fig. 135 will convey an idea of the impression left upon my mind by this examination.

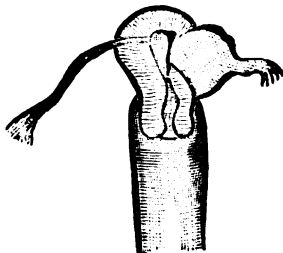

FIG. 135.

From this time the patient progressed without any noteworthy occurrence to complete recovery.

The termination of this form of extra-uterine pregnancy, by expulsion of the foetus and placenta through the uterus (which is under these circumstances brought into action merely as a prolongation of the vagina), is by no means unknown.

The first attempt was made with seventeen ordinary zinc-carbon cells freshly charged. Frequent interruptions were made (about 120 to the minute), and excluding short intervals of rest the patient was under the influence of the current about three minutes. The muscles of the abdomen and limbs were somewhat violently contracted, and some pain was caused, but the patient was perfectly comfortable upon the cessation of treatment. The second application was begun with eighteen cells, and this number was gradually increased to twenty-three.

The second case upon which Dr. Rockwell operated was in the practice of Dr. C. E. Billington, the accuracy of whose diagnosis was again confirmed by Dr. Thomas. The result in this case was entirely successful.

The third case he treated for Dr. Bache Emmet, who had in consultation both Dr. T. Addis Emmet and Dr. T. G. Thomas. Dr. Emmet's account of the case, with its favorable termination, may be found in the *New York Medical Journal*.

In the fourth case he operated for Dr. Everett Herrick, the diagnosis being doubly confirmed by Drs. Thomas and Emmet. In this case

again the fœtus was effectually destroyed, followed by the prompt recovery of the mother.

At the last meeting of the American Gynecological Society at Boston, Dr. T. G. Thomas read an exhaustive paper upon the subject, giving the histories of some twenty cases of extra-uterine pregnancy that had fallen under his observation, together with an account of most of the cases to which allusion has been made, and in which electricity was so successfully used. In addition to these Dr. Rockwell has more recently seen and operated upon three other cases of like character that have never been reported, and which, if possible, even more strongly confirm the incalculable value of the treatment in these dangerous but somewhat rare abnormalities of pregnancy.

The fifth case, which he saw with Dr. N. S. Westcott, was of a most interesting and unusual character, from the fact that with a normal uterine pregnancy was associated what we have every reason to believe was a tubal or extra-uterine pregnancy. Dr. Westcott had previously called Dr. Thomas in consultation, and it was at his suggestion that electricity was used. The patient, a lady, aged about thirty, last menstruated August 6, 1882. Subsequently she complained of more or less discomfort and pain, with tenderness in the region of both ovaries, but especially marked on the left side. On September 18th an internal examination was made, and by conjoined manipulation a small tumor was discovered, about the size of a pullet's egg. It was situated some two inches to the left of the median line, nearly on a level with the brim of the pelvis, and could be moved from Douglas' cul-de-sac toward the margin of the ribs. The tumor gradually increased until it was larger than a billiard-ball. There seemed to be no reasonable doubt as to its character, and on October 24th, the treatment by electricity was attempted.

The constant current was used, with one pole introduced to the mass through the vagina, and the other over the tumor externally and with rapid interruptions. The maximum of current strength employed was eighteen cells, or, to speak more accurately, as different apparatus vary much in electro-motive force, a power of twenty-four volts.

This operation was repeated on October 25th, 28th, and 30th, causing the tumor not only to perceptibly decrease in size, but to change its seat by an inch or so as well. Since the last treatment it has gradually grown smaller, until at the present date it can barely be detected. At the same time there is now developing in the uterus a six months' fœtus.

The sixth case occurred in the person of a young unmarried woman,

residing outside the city limits, and by special request, and for sufficient reasons, the name of the attending physician will not be mentioned. From him the following history was obtained: Two weeks previously he first saw the case professionally, and found that she was suffering much pain in the right side, together with irregular discharges of blood. The patient had confessed to the possibility of pregnancy, and examination elicited many of the objective and subjective signs of this condition. Nausea occurred every morning, and changes had taken place in the areola. Digital examination revealed the fact that the os uteri was little, if any, changed from its normal condition. By pressure over the right side it was possible to feel a certain hardness not present on the other side, but by conjoined manipulation, with one finger in the vagina, a distinct rounded mass could be felt.

Examination per rectum revealed its presence even more distinctly. If pregnancy existed—and of this there seemed to be no reasonable doubt—it had advanced nearly to the fourth month, and as the tumor was large, much larger than in the case just related, there was evidently no time to lose. Dr. Rockwell had brought with him a suitable apparatus, and immediately operated by introducing one pole into the rectum, and placing the other externally. On account of the great distention of the Fallopian tube, and the danger of rupture, he felt the necessity of exercising the utmost care, and consequently made use of the interruptions, with a current strength of but twelve cells, or about sixteen volts. The current would then be quickly increased without interruption and allowed for a moment to pass in a continuous stream. The treatment was concluded by a second application on the following day. Visiting the patient some two weeks subsequently, he found that the tumor had decreased in size at least one-half, and at this time, after the lapse of several months, it may be said, so far as any external evidence of it is concerned, to have entirely disappeared.

The last case is as follows: On December 14, 1882, Dr. Rockwell was informed by Dr. H. Marion Sims, that Mrs. A—, a patient of his, was suffering from extra-uterine pregnancy, and was by him requested to undertake the destruction of the fœtus by electricity.

Although married a number of years, she had never before been pregnant. Dr. Sims, on first discovering the possibilities of this condition, called in consultation Dr. T. Addis Emmet, who positively confirmed the diagnosis. The pregnancy had advanced to the third month, and the tumor, which was about the size of a child's fist, was movable and could be distinctly felt both from without and within.

The size of the enlargement was such that the operation was urged immediately. For fear that the cyst might be in danger of rupture through uncontrollable movements of the patient, Dr. Emmet advised the administration of an anæsthetic.

Ether having been given by Dr. M. H. Nash, Dr. Sims placed the uterine electrode, and shocks from a galvanic current of but sixteen volts in strength were passed through the fœtal mass.

The mildness of the treatment was necessitated because of the unusual nerve-irritability, and the violence of the muscular contractions.

Although it was probable that the destruction of the fœtal life had been effected at the first séance, the operation was repeated on the 18th, 24th, and 27th of December, for the purpose, first, of absolute certainty, and second, to accelerate the absorptive process. The contour and seat of the tumor were not only changed after the first application, but it rapidly decreased in size. The patient experienced no unpleasant effects, and within a short time was able to start for Europe.

In the treatment of extra-uterine pregnancy, it is an important point to be decided, as to the best form of electricity to be used. Not only has galvanism and electro-magnetism been successfully employed, but it is said that the common magneto-electric battery has also proved sufficient; but from both a physical and physiological point of view, and as well through the teachings of experience, we cannot, for our part, doubt that galvanism is preferable to the other forms. It is more certain in its effects. It has a greater power of overcoming resistance, and consequently its influence is felt deeper than the other forms. Four important effects attend the passage of the electric current through the living body, and all these undoubtedly enter as factors, either in destroying the life of the fœtus or in the subsequent process of absorption.

These effects may be designated as mechanical, physical, chemical, and physiological.

The mechanical effects of the interrupted galvanic current are equal to those of the faradic current, while the physical effects, manifested by heat, and the modification of endosmose and exosmose are in the main the results of galvanic action.

By the passage of the galvanic current, the endosmotic phenomena may be both stimulated and reversed. The faradic current from the secondary coil produces no such effect. The current from the inner coil produces these effects, but in a much less degree. Chemical or electrolytic effects, again, are almost wholly the result of galvanic ac-

tion, and it should be remembered that the electrolysis of organic substances starts a process that continues long after the current ceases to flow. The physiological effects of electricity are those which take place by virtue of the vital properties of the body, and, unlike the other effects, are only observed in living substances. Physiological effects are manifested on the circulation, on secretion and excretion, but only as absorption is effected does it interest us here, and it is quite evident that the absorptive powers of the secondary current are quite limited.

In any case of tubal pregnancy, and especially in those advanced conditions where the tube is greatly distended, and there is danger of spontaneous rupture, the possibility of hastening this catastrophe in the attempt to destroy the life of the foetus should never be lost sight of. The tubes themselves are but slightly supplied with muscular fibre, and the danger would more especially arise from the powerful compression that is liable to be exerted by the abdominal muscles, and the effort should be so to diffuse the current proceeding from the external pole as to produce the least mechanical effect possible. In regard to the diagnosis of extra-uterine pregnancy, it must be confessed that it is not always an easy matter, and in the cases just related the question may arise as to its accuracy. The eminence of the gentlemen associated in the cases should perhaps be a sufficiently strong argument for the correctness of the diagnosis, but conclusive evidence lies also in the effects of the treatment itself. The results of the electrolysis are well known, but in no other form of tumor, cystic or otherwise, is it possible for the galvanic current, used as described, to produce similarly prompt and effective results. In regard to the effects of electricity on normal pregnancy, suggested by the case of double pregnancy that we have related, a word may be said. It is a mistake to suppose that abortions are readily produced by electricity. Without the electrode is introduced directly into the uterus, which would of course be sufficient without the passage of any current, the strongest treatment that it is prudent to give may prove insufficient. Of this we have had evidence in several justifiable attempts to bring on a miscarriage. In the case just alluded to the current was strong, applied by shocks, and in close proximity to the uterus, affecting it not only reflexly, but in some measure directly, yet the normal pregnancy was in no ways disturbed; and, so far as concerns general applications for the production of constitutional tonic effects, we have in many instances administered them with impunity through the whole course of gestation, and with the most



happy results. The question may be asked, What becomes of the foetal mass, after its destruction by the electricity? The probability is that it first becomes encysted and then gradually absorbed. At all events, in all of the foregoing cases, the enlargement entirely disappeared within a comparatively short time, and was not the cause of the slightest discomfort.

## . CHAPTER XXXIV.

### ARTIFICIAL RESPIRATION BY ELECTRIZATION IN CASES OF APPARENT DEATH FROM DROWNING, OR SUFFOCATION THROUGH POISONOUS GASES, OR IN ASPHYXIA OF NEW-BORN INFANTS.

THE process of exciting artificial respiration by faradization\* is as follows :

1. *Let an assistant put the head, shoulders, and arms of the patient in a fixed position, while another stands ready to assist the expiratory movements by pressure.*

2. *Graduate the current to a strength sufficient to produce vigorous contractions of the muscles of the ball of the thumb, and then press the sponge electrodes (which should be of large size and well moistened) firmly over the phrenic nerves at the outer borders of the sterno-cleido-mastoid muscles and at the lower end of the scaleni muscles.*

3. *Interrupt the current (either by removing one of the electrodes, or by an interrupter), about three times a minute, while the assistant presses firmly on the abdomen, pausing occasionally to observe the effect.*

4. *If after a number of interruptions no inspiratory movements appear, increase the strength of the current.*

In some cases it is sufficient to put one electrode over the phrenic nerve and the other in the seventh intercostal space.

Large electrodes are used so as to affect the other muscles which have a share in inspiration (scalenus-anticus and sterno-cleido-mastoid) simultaneously with the phrenic nerve. The object of holding the arms and shoulders in a fixed position is to prevent the interference which may arise from the contractions of the muscles of the arms, and at the same time to obtain the co-operation of the serratus and pectoral muscles.

Prof. Ziemssen, who first proposed this method of producing artificial respiration, advises the trial of the galvanic current in those cases

\* The faradic current is usually employed for this purpose, although the interrupted galvanic current might answer the purpose.

where the irritability is lost to the faradic. The same writer presents a number of successful results in cases of poisoning by carbonic acid gas with this method of treatment from his own and other experience.\*

In *opium poisoning* artificial respiration by faradization may be tried either alone or in connection with other methods. Dr. Iram has reported a case of opium poisoning, which recovered on the application of one pole to the neck and the other to the perinæum, after tannin, coffee, and tartar emetic had been unsuccessfully employed for several hours.

Those who attempt to produce artificial respiration in emergencies are frequently unfamiliar with the *motor point* (see p. 287) of the phrenic, and therefore apply the pole in the neck indiscriminately. A medical acquaintance informs us that an attempt of this kind which he made in a case of opium poisoning proved *instantaneously fatal to the patient*. Under ordinary methods the patient was recovering, but in order to expedite the progress, faradization was tried. One pole was placed on the ribs, and the other somewhere in the neck, in order to find the phrenic nerve. Immediately the patient *ceased to breathe*, and no further treatment availed to resuscitate her.

This case, so far as we know, is unprecedented. It is explicable only on the theory that the shock of the sudden closure of the current near the nervous centre destroyed the waning life by concussion.

This unique and unfortunate case should not deter any physician from resorting to the electric method of artificial respiration in all cases where it is indicated, any more than the equally unique case of blindness produced by the galvanic current (recorded by Duchenne) should deter us from galvanizing the eyes and face.

Meyer records a successful result in a case of threatened death from exhaustion after diphtheria.†

Friedberg‡ succeeded in restoring a child of four years, asphyxiate by chloroform, by this method, combined with compression of the diaphragm.§

Many failures have been made in the attempt to produce artificial respiration by faradization, because the operators were ignorant of the true method of application, or were not sufficiently persevering.

Dr. Beard has twice failed to resuscitate dogs that were narcotized by

\* Die Electricität in der Medicin, 1866, p. 174 et seq.

† Op. cit., p. 431.

‡ Quoted by Meyer, op. cit., pp. 431, 432.

§ Irritation of the phrenic nerve might be readily combined with Howard's method of artificial respiration.

chloroform, although the applications were begun in less than a minute after the heart ceased to pulsate.

He failed also in a case of opium poisoning in an infant six weeks old.

Some remarkable results have been reported where life was saved by faradization around the neck and chest, kept up by intervals for many hours.

Dr. Allan McLane Hamilton, from a number of interesting experiments undertaken to test the utility of electricity in asphyxia, concludes as follows :—

1st. That it is useless to expect good results if five minutes have elapsed since life appeared extinct.

2d. That the current should be applied faithfully and *steadily*, one pole being placed on the ensiform cartilage, the other on the base of the skull or over the tracks of the great nerves of the neck.

3d. That the faradic and interrupted galvanic currents are the best.

4th. That the current should be applied some time after respiratory movements have become regular.\*

*Resuscitation of New-born Children.*—Successful experiments in the resuscitation of new-born children have been made by Schulz and Pernice. The latter succeeded in three out of five cases. In one of his cases the child was born to all appearance dead. Restoration was accomplished in half or three-quarters of an hour by the alternate use of the warm bath and faradization of the phrenic nerve.

Legros and Onimus † have experimented on animals—rats, dogs—with a view to bringing on resuscitation during syncope from loss of blood. They used the galvanic current, placing the negative pole in the mouth and the positive in the bowels.

Dr. Rockwell has treated several cases of suspended respiration. A new-born babe was to all appearances dead ; faradization of the phrenic nerve resulted in decided manifestations of life for a few moments only. In the case of a lady who was in a state of asphyxia—from a subcutaneous injection of morphine—faradization of the phrenic nerve excited respiratory movements which were repeated some twelve or fifteen times after the current ceased to pass. He did not succeed in saving the patient.

\* Electricity as a Means of Resuscitation. *American Practitioner*, Oct., 1872.

† *Gaz. des Hôp.*, No. 53.

## CHAPTER XXXV.

### DISEASES OF THE HEART AND LUNGS

*Palpitation of the Heart.*—That galvanization of the sympathetic and general electrization have a positively accelerating or sedative effect on the action of the heart, we have demonstrated by a large number of experiments. (See Electro-Physiology.) This effect is produced by the action of the current on the sympathetic or the pneumogastric in the neck, or in general electrization it may also result, secondarily, from the influence that the system at large receives from the application.

Cases of functional disturbance of the heart, associated with dyspepsia and hysteria and anæmia, we have found to yield to general faradization in a large variety of instances, even when no special attention was directed to the sympathetic or the pneumogastric

Fliess experimented with the galvanic current in twenty-four cases, nineteen of which were functional, and five of an organic character.

All the cases were more or less relieved, even those dependent on structural lesion, while the majority of the functional cases were permanently cured.

His method of treatment was the daily application to the pneumogastric in the neck of mild, descending, galvanic currents, for one or two minutes. Temporary abatement of the symptoms followed each application.

The treatment of functional palpitation of the heart is certainly worthy of more attention than it has thus far received from electrotherapeutists.

*Palpitation of the heart associated with dyspepsia—Unusual susceptibility to the current—Great improvement under general faradization.*

CASE CLXXI.—Mr. B., of New Jersey, applied to us March 1st, 1867, with the symptoms of weakness of the stomach and liver, and also of functional derangement of the heart. He was tall, somewhat spare, but of fair muscular development. His occupation was that of a farmer, but for some time before he visited us he had been unable to make any protracted exertion. He had tested various kinds of internal medicines, and with unsatisfactory results.

During the first application he was momentarily overcome by a feeling of faintness, but at once rallied, and went away feeling stronger and brighter. He continued to visit us two or three times a week, for nearly two months. The improvement was slow, but very positive, with occasional temporary relapses. The cardiac symptoms gradually diminished, and his strength increased to such an extent that he was able to resume in part his daily avocation.

When he left us his digestive functions were well performed, and he had made arrangements to enter upon an active and pleasant out-door employment.

*Angina Pectoris.*—The treatment of angina pectoris has ever been unsatisfactory. The cases that have fallen under our observation were mostly of a chronic character, and turned to electro-therapeutics as a last resort. As illustrative of the best result that we have been able to obtain in the treatment of this remarkable disorder, the following case is presented :

*Angina pectoris—Probably of an idiopathic character—Recovery unacr general faradization.*

CASE CLXXII.—The patient was a stout, vigorous man, aged 48, and for eighteen months he had been the victim of violent, sharp, shooting pains, under the sternum, in the left shoulder and arm. Frequently the neck would suffer, and occasionally the left leg. Physical exploration gave no evidence of organic disease; and as it was impossible to find any external exciting cause, we attributed the symptoms to idiopathic causes. When he moved more rapidly than usual, or over-exerted himself in any way, he was liable to be seized with a violent sense of constriction in the chest, which caused him to feel as if about to die. In a moment the radiating pains described above would follow, and compel him to stop perfectly still. His appetite and digestion were but little, if any, impaired; yet, from the first, the frequency and severity of the attacks had gradually increased. As a rule, a paroxysm occurred every day, and frequently several times during the twenty-four hours. Occasionally, however, a week would pass without an attack.

We made use of general faradization when he was entirely free from any uneasiness. Three days elapsed before he again came to us, but during this interval the malady had not manifested itself.

Before administering the second application, the patient purposely brought on a paroxysm by violently swinging his arms and bending his body. In the midst of the pain the positive pole was suddenly applied over the nipple, and a very intense current sent through the body. With the rapidity of the passage of the electricity itself, the pain left him, and after the séance had closed, he found it impossible, by any effort he could make, to bring on another attack. At the next visit, three days subsequently, he was able, by very violent efforts, to bring on a paroxysm, but of far less severity than before. Similar treatment, by localized faradization, immediately relieved him. A few more applications were given, but during his visits to us he never succeeded in exciting another attack, that we might have the pleasure of subduing it. For several months after he was discharged as cured, he had no return of the angina.

*Angina pectoris—Decided relief under central galvanization—Relapse.*

CASE CLXXIII.—Mr. H. M., aged 35, referred to us by Dr. Leaming, had for twenty years been a sufferer from cardiac palpitations, with some of the symptoms of angina pectoris. The cardiac palpitation seemed to have a relation to the condition of the stomach, being associated with and apparently dependent on attacks of indigestion, attended with regurgitation and pyrosis. It was one of those cases where it was difficult to determine precisely in what organ, or nerve, or nerve plexus, the symptoms took their origin. The patient was not remarkably intelligent, but so far as could be gleaned from his history, the attacks involved both the heart and the stomach, for it was certain that anything that excited indigestion often ushered in paroxysms of great severity. Organic disease of the heart had been suspected, but Dr. Leaming, a skilful and practised auscultator, decided that there was no such lesion. Medicine had accomplished but little for the patient, and we decided to use central galvanization. The first application was mild and brief, but it caused much dizziness, and for the moment alarmed and worried the patient. In a few days, however, he began to improve in his symptoms, and began also to bear the current better. For about two months the patient persevered in taking the treatment, and with most decided improvement.

While the cure was not perfect, yet all his symptoms were so alleviated, that life became, in a measure, enjoyable, instead of a heavy and constant burden. Subsequently he relapsed.

We may have, as illustrated by the following case, a retrocession of the rheumatic or gouty diathesis to the heart, and, according to some writers, to the lungs also, producing an incurable organic lesion that may result in this neurosis. A metastasis to the stomach, of either of the two diseases just mentioned, may give rise also, according to others, to symptoms of cardiac neuralgia.

*Angina pectoris following repeated attacks of gout—Aggravated temporarily by strong galvanization—Relieved by mild general faradization.*

CASE CLXXIV.—Mr. B., aged 52, was referred to us by the late Professor Geo. T. Elliott. The patient was a stout, plethoric man, somewhat advanced in years beyond the middle period of life. He was perhaps what might be called a "high liver," and for years he had indulged in wines freely, although not to great excess.

He had on two or more occasions suffered quite severely from attacks of gout of the great toe, and very soon after recovery from the last attack, he began to experience slight symptoms of his present difficulty. The pain generally commenced in the chest, behind and a little to the left side of the sternum, and extended to the shoulder and down the leg.

Occasionally, the symptoms would first manifest themselves in the leg, and then extend to the heart.

The paroxysms were never severe, so long as a quiet posture was maintained, but the exertion of ascending one or two flights of stairs, or walking a few blocks, almost invariably excited much pain, accompanied with a very distressing shortness of breath. The patient remarked, as a singular fact, that while such slight efforts readily caused

cardiac distress, it was possible for him to exercise quite violently with light dumb-bells, and yet suffer from none of the evil effects that might from analogy be expected to follow. The first two applications, given in November, 1867, were followed by no special results.

Treatment with a powerful faradic current, on a third occasion, considerably aggravated the symptoms. The fourth application, given with a milder current, worked an immediate change for the better.

The pain was immediately dissipated, and for two days, until we saw him again, he was far better than he had been for months. He walked a long distance without being at all oppressed in breathing, and at night he was quite comfortable, although heretofore his symptoms were, as a rule, much aggravated at this time. On the left side of the neck, the application excited pain that proceeded toward the chest. On the right side, no such effect was noticed. Without detailing farther the incidents connected with this case, we will simply say that treatment by both currents, together with persistent medication, accomplished merely occasional and temporary amelioration of his distressing symptoms. It is true that physical exploration gave no evidence of organic lesion, but in consideration of the undoubted gouty diathesis, together with the persistent character of the symptoms, there could be no hesitation in declaring the existence of some irreparable structural disease. It is impossible to account for the temporary but marked amelioration that on different occasions followed the applications, without we refer it to the mild anæsthetic effect of the faradic current.

*Diseases of the Lungs.*—For diseases of the lungs electrization has accomplished less than in any other department. The recognized gravity of phthisis, together with the *a priori* improbability that it could be directly cured by any known methods of using electricity—these two causes have deterred electro-therapeutists from making even experimental applications to diseased lungs. One author—Bastings,\* of Brussels—however, has reported most astounding results from faradization of the muscles of the chest. If we accept in good faith the statements of this author, even the second stages of phthisis may be cured by this method, which seems to affect the lungs not directly, but indirectly, through the muscular development which it causes, and the greater amount of oxygen which it enables the lungs to breathe.

The amazing statements which the author advances, concerning the cure of consumption, are entitled to more consideration than they would otherwise receive, from the fact that the fundamental idea on which his treatment is based, namely, that faradization of the muscles—electro-muscular gymnastics—markedly increases their size and strength, and also improves the general nutrition, is eminently sound and thoroughly demonstrable, as we have shown during all our investigations in electro-therapeutics.

\* *Die Lungenschwindsucht und ihre Heilung durch Electricität.* Translated from the French by Dr. Silbermann. Erlangen, 1866.



Vaust \* has experimented with the method of Bastings—electro-muscular gymnastics—in growing children, who were not affected with any special diathesis, but who “*presented the appearance of debility, languor, and lack of force so frequently found among the poorer classes.*”

The results were “wonderful.” Not only were the muscles of the chest greatly increased in size after a number of applications, but their “breathing was deeper, their appetites better, and they were more cheerful and lively.”

After six months’ treatment the increase was still more marked in some of the cases. According to our experience, the growth of the muscles under faradization is at first quite rapid, but subsequently much slower, and in a few months becomes stationary.

Bastings has used these electro-muscular gymnastics in consumption, not with a view to directly affect the tuberculous deposit at all, but, by strengthening the muscles of the chest, to so improve the respiratory power that more air can be inspired, and so benefit result to the healthy portion of the lung, and indirectly, through better oxygenation of the blood, to a certain extent on the diseased portion and on the whole system.

The method and principles of treatment in all his cases was substantially similar—electro-muscular gymnastics: about half a minute was given to each muscle, and about five minutes to each sitting. *Prolonged treatment was found to be injurious.*

The general statements of the author were confirmed by Dr. Bougard, † who affirms that the patients remain cured for one, two, or three years.

Dr. Crocq also speaks favorably of the method of Bastings, although in the treatment under his own direction of the very severe cases of consumption in the St. John Hospital he obtained no positive results.

Although the beneficial effects of muscular exercise in consumption have long been conceded, yet, in the present state of the professional mind on the subject, the statements of Bastings will need more numerous indorsements before they are accepted.

We would suggest a method of treating pulmonary tuberculosis, which, so far as we know, has not been used, but which is surely worthy of a trial. This method would consist in external galvanization of the diseased portion of the lung with a mild stable current. The electric current might thus act on the diseased lung, as it acts on inflamed and ulcerated surfaces elsewhere.

\* *Medicinisches Journal*, vol. 38, Juni 1864, p. 599. Sitzung der Gesellschaft für Medicin und Naturwissenschaften zu Brüssel, vom 2. Mai 1864. This paper is presented in the work of Bastings, above quoted, p. 119 et seq.

† *Op. cit.*, p. 147. *Loc. cit.*, p. 142 et seq.

## CHAPTER XXXVI.

### EXOPHTHALMIC GOITRE.

EXOPHTHALMIC goitre is so comparatively infrequent, and its pathology so imperfectly understood, that its therapeutics have necessarily been more or less uncertain. When, therefore, the use of electricity is suggested, the question that first arises in the minds of those who have but little practical experience in methods of electrical treatment, relates to the kind of current and the details of its application. In regard to the current, every physiological consideration and all experience points to galvanism as pre-eminently indicated, and yet we must bear testimony to the fact that the faradic current is not in every case useless. The applications, however, must not be *local* but *general*, after the method of general faradization, and in a certain proportion of cases where there is anæmia, with marked nervous irritability and physical weakness, benefit will certainly follow, provided always that the operator will take sufficient trouble to appreciate the various steps of the process and make his applications practically efficient.

In the use of the galvanic current upon which we are mainly to rely, we have obtained good results by placing the cathode over the cilio-spinal centre above the seventh cervical vertebra, and the anode in the auriculo-maxillary fossa, gradually drawing the latter (after a few moments of stable treatment) along the inner border of the sternocleido-mastoid muscle to its lower extremity. The second step in this process consists in removing the anode to the position occupied by the cathode, and placing the latter over the solar plexus, using for a minute or so longer a greatly increased strength of current.

In one case, failing after considerable effort to accomplish more than a very moderate degree of amelioration of the symptoms, we made use of currents that were rapidly increased and diminished every few seconds, as described in Case 181, with very great benefit.

Subsequently to this we came across a case originally published by Dr. Ancona, in the *Giornale Veneto di scienze mediche*, which had escaped our notice, where an obstinate and severe case of Graves' disease had been cured by this method of current interruption. The cure was accomplished only after the administration of one hundred appli-

cations. Exophthalmic goitre is undoubtedly of centric origin, and in many cases structural changes of the sympathetic must underlie all the observed symptoms. On the other hand, the rapid recoveries that have been known to follow the administration of certain methods of treatment, render it in the highest degree probable that the symptoms may depend as well on functional causes alone. Its onset and course have been so frequently and fully described that it seems entirely unnecessary to attempt any detailed description of its numerous symptoms other than what will be found in the accompanying cases. One fact, however, in our own experience, that will be noted as the cases are given, strikes us as worthy of a moment's attention, and that is, the frequency of the disease in its incomplete form. By this is meant the cases where the exophthalmus, the thyroid enlargement, or the cardiac symptoms were either absent or but slightly developed.

In three cases the eyes were very little, if at all, affected, while the cardiac palpitation and thyroid swelling were very decided. In one case the pulse was but 88, while the other two symptoms were distinctly present. In every case, however, that has fallen under our observation, the thyroid was large and pulsating; and yet Trousseau and others report cases which they regard as true examples of Graves' disease, where there was little, if any, evidence of glandular enlargement.

*Exophthalmic goitre of one year's standing—Increased temperature—Recovery follows fifteen applications of galvanism.*

CASE CLXXV.—The patient, John L—, was a pale, slim man, aged 29, and by occupation a compositor. The three cardinal symptoms of the disease, viz.: exophthalmus, swelling of the thyroid gland, and palpitation, were present in a marked degree, and in addition there was a want of harmony between the movements of the upper eyelid and eyeball, a phenomenon first observed by Von Graefe, and by him regarded as pathognomonic.

The history and antecedents of the case are as follows: The mother, now deceased, suffered from epileptic seizures from the earliest remembrance of our patient, while an older sister was the victim of frequent and severe attacks of hysteria. The father had been intemperate, and died of delirium tremens. It would thus seem that we had in this history ground for a belief in the importance of the relation of hereditary influences to these conditions.

The health of the patient up to his twenty-fifth year had been uniformly good, and the only evidence of a neurotic predisposition was an occasional and unexplainable tendency to insomnia for a year or so previous to the first symptoms of his disease. We first saw the man July 6, 1879.

During the summer of 1878 he observed a slight swelling of the thyroid; very soon after, considerable palpitation; and later still, protrusion of the eyeballs. It is to be

noted in passing that the order of the onset of the symptoms is unusual, the thyroid enlargement usually being second in order of development instead of first.

On our first examination we found the gland enlarged to about the size of the fist of a child of ten years, the pulse beating in frequency, 125 to the minute, while the protrusion of the globe of the eye was as great as in any case we have seen. By subsequent examination we found that the pulse ranged from 110 to 130. On three different occasions, where the axillary thermometer was used, it marked 100°, 101°, 100.4°. The appetite of the patient was poor, his secretions disordered, and his general strength impaired. After some preliminary medication of a corrective nature, we gave the ordinary prescription of quinine and iron, and at the same time began the applications of the galvanic current.

The force and rapidity of the heart-beats were greatly modified; and accompanying, or rather following, by a week or ten days, this subsidence of the violent palpitation, there was a very noticeable decrease of the exophthalmus. A decrease in the size of the thyroid was not observed until some days after, and disappeared with much less rapidity than the other symptoms. In order to hasten the cure, we very carefully performed electrolysis on two occasions, and with evident benefit.

At the date of writing, August 20, 1879, after having received fifteen applications, the patient has, so far as relates to the palpitation and exophthalmus, entirely recovered.

The goitre has decreased in size fully two-thirds, and is quite hard and firm, a change which is to be attributed, in all probability, to a hyperplasia of the glandular tissue taking the place of the dilated vessels.

We place the following case on record, not only because of the benefit accruing from treatment, but as illustrative also of two rare symptoms in connection with Graves' disease, viz.: 1st. Dilatation of the pupils. 2d. Swelling and pulsation in the region of the solar plexus. We are not, indeed, aware that any case of Graves' disease, in which this last symptom may have possibly been observed, has ever before been published.

Accepting the theory of a disturbance of the sympathetic as a cause of this affection, it is not remarkable that its lower, as well as its upper ganglia, should be the seat of the disease, sufficient to cause a dilatation of the vessels branching from the cœliac axis, analogous to that observed in the arteries of the thyroid gland. In consideration of the rarity of this symptom, therefore, it is interesting to recall the fact, that in eight autopsies where changes were observed in the sympathetic and its ganglia, they were confined to the cervical portion, the thoracic and abdominal sympathetic being entirely healthy.

In this case there must necessarily have been marked disturbance of the lower ganglia, but the complete and permanent disappearance of the gastric swelling would seem to preclude the probability of the existence of any lesion.

In the very few cases of exophthalmic goitre in which dilatation of the pupils has been observed, the cause is supposed to be due to a "paralysis of the pupillary branch of the oculo-motor nerve, consequent on neuro-paralytic dilatation of the vessels. The isolated paralysis of this branch (the other fibres of the motor oculi remaining unaffected) is referred by Stellwag to the fact that the branches destined for the pupil do not join the other oculo-motor fibres until after the latter have crossed the crura cerebri, and that they have been proved to originate from several centres of various function."

*Exophthalmic goitre, with bilateral perspiration, enlarged pupils, etc.—Rapid and decided relief, but not a perfect recovery.*

CASE CLXXVI.—Mrs. G—, aged about 40, came to us for the relief of an exophthalmic goitre, May 3, 1876. The eyes were much protruded, the thyroid prominent, and the cardiac palpitation violent. The average frequency of the pulse was about 115, but on various occasions we found that it was beating at the rate of 140 to the minute. The patient was annoyed by profuse bilateral perspiration, *the pupils were enlarged*, and vertigo was a frequent symptom. The appetite was generally good, but she complained of much nausea.

She referred to one other symptom, which, if related to the disease as an effect, as it would seem, was quite new to us. Subsequent to the development of the three cardinal symptoms, which occurred in the following order—palpitation, thyroid enlargement, exophthalmus, a swelling appeared near the pit of the stomach, which in size and vigor of pulsation was more marked than the goitre. We may remark that Dr. S. S. Purple, of New York, had attended the patient in several confinements, and was cognizant of the disease in question.

Dr. Purple informed us that she had suffered much from malarial poison, to which, together with the effects of a labor of some severity shortly previous, might possibly be attributed the symptoms in question. The first signs of the disease were manifest some three years before she came under our observation.

We administered to this patient seventeen applications, ten of which were with the galvanic current, locally applied, while seven were with the faradic current, and were more general in their nature. Amelioration followed very quickly, and at this date (1880) the only symptoms of the disease is a very slight swelling of the thyroid, and, in a modified form, a tendency to occasional cardiac palpitations.

*Exophthalmic goitre associated with spinal irritation—Approximate recovery follows galvanization and general faradization.*

CASE CLXXVII.—Mrs. E—, aged 31, married, and the mother of two children, was seen with Dr. I. B. Read. She first observed an appreciable increase in the rapidity of the heart's action in the fall of 1878. About the same time, or soon after, as she was standing before the mirror, her attention was called to an increased fulness about the neck, and, upon passing her hand over the part, she became aware of what she termed a beating sensation and a softer feeling. These symptoms increased somewhat rapidly, until they assumed the condition presented when the case came to us in October, 1879. At this time the heart was beating at the rate of 120 to 125

per minute, and on exercise or under excitement it went up to 150 per minute. The thyroid enlargement was marked, though not enormous, while the eyes were quite protuberant and bloodshot.

Around the neck, over the thyroid gland, the measurement was fifteen inches. The patient was chlorotic, hysterical, and nervous to the last degree, and it was with the greatest difficulty that she could be induced to submit to the necessary examination and treatment. The spine was exceedingly sensitive to pressure all along its course, and especially between the scapulae, where firm pressure invariably caused nausea; and on the occasion of her second visit, while running our fingers down the back, and lingering for a moment with a somewhat increased pressure over the more sensitive portion, she immediately but quietly rejected her breakfast, which had been taken an hour before.

It is to be remarked that these evidences of spinal irritation and extreme nervousness became manifest only after the appearance of symptoms indicating exophthalmic goitre. The only cause which seemed to bear any relation to the onset of the disease was the one that has been so frequently observed, viz., childbirth. A short time previously she had suffered from a long and tedious confinement, but her recovery had been apparently quite satisfactory. We submitted her to the usual methods of galvanization of the sympathetic and central galvanization, and with some benefit. The heart's action became somewhat more regular and less frequent, the goitre decreased a little in size, and the spine became less sensitive.

Improvement, however, ceased at this point, and the case remaining stationary for nearly a month we attempted general faradization.

We have on several occasions pointed out the fact that general faradization is often most effective in lowering a pulse that is rapid, as a resultant of nervous excitement, and increasing its *strength* as well, when it is both rapid and weak through nervous exhaustion. This effect upon the pulse, as experience shows, and as electro-physiology teaches, is most frequently observed in exophthalmic goitre after the use of the galvanic current.

In this case, however, after galvanization had ceased to be effective, general faradization was followed by a still greater diminution in the frequency of the pulse, by decrease in the thyroid, and lessened sensibility along the spine. After twenty-five applications of general faradization, administered in the course of two months, the measurement of the neck had decreased by two inches, leaving a very slight but hard enlargement in place of the larger and softer tumor that was present at the beginning of treatment. The frequency of the pulse decreased to about 85 per minute, and was not particularly susceptible to sudden fluctuations under excitement or exertion, while she had gained immensely in nervous strength and self-control.

*Exophthalmic goitre of two years' standing.—Treatment results in but slight benefit.*

CASE CLXXVIII.—Miss M—, aged 22, was seen with Dr. E. B. Belden, Oct. 18, 1879. Menstruation began at the age of seventeen, but was scanty and irregular for two years, after which for awhile it appeared normally. At the age of twenty, menstruation again became irregular, and attended also with cramps and considerable pain. At this time appeared the first evidences of exophthalmic goitre, and when we saw her two years subsequently, the three cardinal symptoms of the disease were

quite pronounced, although moderate in degree compared to the foregoing. The pulse averaged about 88 per minute. The eyes were slightly protuberant, while the neck measurement over the enlarged gland was fifteen inches. Opportunity was afforded of seeing this patient but a comparatively short time, but in the few applications that were given, the circumference of the neck over the gland was reduced to fourteen and one-quarter inches.

The pulse, however, became markedly modified, decreasing to the normal standard, 72 per minute.

As we are recording this case, the patient again calls at our office. It is now five months since the treatment was discontinued, and the pulse is found to be 72, the same as recorded at that time. The neck measures fourteen and a half inches, showing a slight increase during the interval, although smaller by one-half of an inch than it was previous to submitting to treatment.

An interesting, though not remarkable fact, connected with the case, is its relation to the menstrual function. At the age of twenty, when menstruation became irregular and scanty, the disease began to manifest itself. Two years subsequently the diminution in the goitre and decrease in the frequency of the pulse were simultaneous with a more regular and altogether better performance of menstruation. After the cessation of the treatment she remained better until a short time before this last visit to which we have just alluded, when there was a retention of the menses, followed by some increase in the size of the thyroid, and an accelerated action of the heart. Through the administration of medicine, menstruation was established in about a week, resulting in a modification of the symptoms that had been excited.

*Exophthalmic goitre.—Pulse exceedingly rapid.—Eyes slightly protuberant.—Very little, if any, benefit follows treatment.*

CASE CLXXIX.—Mrs. C— was seen with Dr. Frank Wilmuth, of Orange, N. J., Nov. 17, 1879. The enlargement of the thyroid was considerable, but the eyes were not at all affected. The pulse was rapid, beating ordinarily at 125 per minute, but reaching 160 when under excitement.

When asleep, it was but 95. The patient was the mother of two children, and although her last labor, four years since, was somewhat severe, it could hardly have entered as a factor in the causation of the disease, since the first evidences of cardiac disturbance appeared three years subsequently. The symptoms were coincident with exhaustion, following hard work at house cleaning. The patient submitted to considerable treatment, but her residence was at such a distance that the visits were necessarily rather infrequent. It is by no means clear to our mind, that the necessity of riding so far, both before and after each visit, did not interfere somewhat with the efficacy of the treatment. At all events, no impression was made upon the disease, other than some slight diminution in the rapidity of the pulse.

*Exophthalmic goitre in a lady aged thirty-four.—Interesting modification of the pulse-beats by galvanization.*

CASE CLXXX.—Miss —, aged 34, came to us from Dr. James Collard, of Westfield, Mass., with a goitre of considerable size, but with very slight protuberance of the eyes. Pulse, 112. Menstruation was normal, but the patient was extremely nervous and depressed. Her mother has an enormous goitre, which has been

developing for thirty years. Both brother and sister died of hasty consumption, and five years ago the patient herself had a slight hemorrhage. The pulse was found to intermit some eight times a minute.

We saw the patient but three weeks when she was compelled to leave the city, although it is proposed to continue the treatment elsewhere.

Under the short treatment that she received, the pulse lost its intermittent character and became entirely regular. At the same time the patient was rendered much less nervous.

Aside from this but little was accomplished. The case is, however, especially worthy of record, because of the very interesting temporary results that followed various applications.

On counting the pulse *during* the first galvanic application, no intermission was detected. A few moments after the removal of the electrodes, it intermitted as usual, eight beats to the minute. The same results followed a second application, with the exception that after the removal of the electrodes the pulse began to intermit but three or four times a minute, and after the fourth application it became permanently rhythmical. At one time during the treatment the pulse fell to 67 and so remained for some time.

*Exophthalmic goitre of five years' duration—Recovery under currents of galvanism, alternately increased and diminished.*

CASE CLXXXI.—Miss C. H.—, aged 29, came to us September, 1879, with an especially interesting and instructive history, since it illustrates how varying may be the manifestations of a nervous diathesis.

During childhood she had suffered long and severely from St. Vitus' dance, which did not entirely disappear till menstruation was established at the age of fourteen. From the first this function was performed irregularly and painfully until the age of eighteen, when it suddenly ceased, and for several years she was afflicted with periodical hysterical seizures, together with a more or less constant jerking of the head, with a hesitancy of utterance and an occasional partial loss of consciousness that simulated attacks of hystero-epilepsy. At the age of twenty-one menstruation again appeared, but irregularly, and at the same time her general health somewhat improved. In time her courses came on more regularly and less painfully, but at the age of twenty-four, after an attack of malarial fever, menstruation failed to reappear.

It was at this time that she began to be annoyed by an excessive palpitation of the heart following exertion, and very soon her attention was called to a decided enlargement of the thyroid. This enlargement gradually increased, and when we saw her, about a year subsequently, it was very large, soft, and pulsating. The measurement around the neck over the tumor was sixteen and one-quarter inches.

The pulse beat at the rate of 110 per minute—while the exophthalmus was very great.

After the patient had been subjected for a short time to the usual external treatment by the galvanic current, but without any special reference in its direction to the menstrual function, the courses appeared slightly for a day and then ceased. On examining the pulse, however, it was found that it had decreased in frequency to somewhat less than 100.

The same method was repeated for some three weeks longer, when we had the



pleasure of showing the case to Dr. P. B. Porter. At this time the pulse was about 90, and the tumor had decreased but about an inch. The exophthalmus had been only slightly influenced.

Deciding to change the method of treatment, we placed one electrode (the anode) directly behind the angle of the lower jaw, pressing back the sterno-cleido muscles, and the other on the back of the neck, a little to one side of the sixth cervical vertebra. Instead, now, of treating by means of an even continuous current, we brought into the circuit a simple water rheostat, and by this means, somewhat rapidly but without shock, increased and decreased the strength of the current through a seance of not more than two or three minutes' duration. The results of this method of treatment were soon manifested in a further reduction of the pulse, and a gradual diminution in the severity of the other symptoms, until after some twenty-five of these applications, recovery seemed complete. The pulse was 75; the eyes resumed their natural position and appearance, while the neck—although somewhat fuller than normal—measured but thirteen and three quarter inches, a decrease of two and a half inches.

While it is quite evident that in this disease the sympathetic is at fault, it is open to question whether the dilatation of vessels, which are such important factors in causing the thyroid enlargement and exophthalmus, is of a passive nature, due to paralysis of the sympathetic, or of an active nature, due, on the contrary, to an irritation of the dilator fibres which run in the sympathetic.\* Accepting either theory, we find ample ground upon which to base indications for the use of the galvanic current. In case we accept the irritant theory, the very powerful sedative effects which may be obtained from the remedy is a sufficient explanation of the *rationale* of its use; while the fact that both physiological investigation and clinical experience has shown that electricity is the remedy *par excellence* for most forms of paralysis, quite clearly points to its use in cases where there is actual paresis of the nerve itself. In addition to the hyperæmia of vessels as a cause of exophthalmus, there may be also accumulations of fat in the cellular tissues of the orbit, which is probably the main cause in certain cases why the protrusion of the eyes still remain prominent after a decided amelioration of every other symptom.

\* The suggestion that the arterial dilatation is due to irritation of the dilator fibres is offered by Benedict, based upon the experiments of Bernard, Schiff, Ludwig, and Loven.

## CHAPTER XXXVII.

### SEQUELÆ OF ACUTE DISEASES (DIPHTHERIA—CEREBRO-SPINAL MENINGITIS—TYPHO-MALARIAL FEVER).

THE sequelæ of several acute inflammatory diseases, and especially of diphtheria and cerebro-spinal meningitis, are of well known severity and persistency. It is generally understood also that electricity in some form may perhaps be indicted in such conditions, particularly in diphtheria, and its use, which is occasionally attempted, has been followed by more or less benefit. We are quite sure, however, that the profession at large, in city as well as country, has a very inadequate idea of the vast benefit accruing from the use of this remedy in these cases. Frequent inquiries in regard to experience in this direction, and the lack of published clinical reports, would seem to justify this opinion, and suggest the propriety of detailing a few of the more unique and interesting histories that we have collected.

*Diphtheria.*—Our first experience in the treatment of the sequelæ of diphtheria by electricity dates back some ten years, when we were called by Dr. James Anderson to see an obstinate case of paralysis of the vocal chords and the laryngeal muscles.

The symptoms yielded readily to treatment, and to the present time we have treated twenty-four cases of diphtheritic paralysis, and with the exception of two, which discontinued treatment almost as soon as begun, the results in each were too striking to permit of any doubt as to the efficacy of the remedy.

Of the twenty-two remaining cases, many of which were of great persistency and severity, nine were sent to us at different times through the kindness of Drs. Markœ, McLean, Farrington, and the late Drs. Peaslee and Gregory.

Of the remaining thirteen, a few had been treated electrically, but, as a rule, with little regularity or intelligence, while several others first had their attention called to electricity as a remedy for their condition by laymen, and so fell into our hands. One of the most interesting and instructive cases that we have seen occurred in the person of a practicing physician of this city, who had also been under the observation of Professor Loomis, Dr. A. N. Brockway, and several others

The doctor has kindly written out the details of his own case, substantially as here given.

*Cardiac difficulty, with partial paralysis of three months' standing, following diphtheria.—Rapid recovery under general faradization.*

CASE CLXXXII. —Three weeks after the disappearance of the diphtheritic patches, paralysis of the pharyngeal and laryngeal muscles began to show itself, accompanied by absolute loss of sensibility of the velum pendulum palati. In consequence, the effort of swallowing was exceedingly difficult, and regurgitation through the nares was unavoidable in the act of drinking. The voice was altered, becoming weak and coarser in tone. Musical notes were impossible.

At the same time, and, indeed, from the tenth day of the acute attack, cardiac difficulty, was indicated by a very feeble, soft, slow pulse, averaging sixty per minute.

On one occasion, three weeks after the soreness of the throat had entirely disappeared, and immediately following special exertion, the pulse quickly rose to 160, and as suddenly fell to 32 per minute, resulting in an attack of angina pectoris which persisted for nearly three hours. This sudden fluctuation of the pulse was most alarming, and caused apprehension of immediate dissolution. For over an hour the pulse remained at 32, when it gradually increased until it reached 58, where it remained.

Four weeks after convalescence from the patches, ciliary paralysis appeared, so that painful fatigue was experienced in reading, etc. Vision corrected by +38 glasses spherical; at the same time the fingers became anæsthetic, with tingling, and inability to pick up small objects, or to button clothing, etc.

The partial paralysis extended to the arms, and finally the legs were similarly affected, becoming heavy, cold, and painful to the touch. Marked inaction of the bowels continued throughout the case; micturition was not interfered with, but there was great numbness and increased sensibility of the external organs. For three months these symptoms persisted without abatement, and were invariably increased by the slightest exercise.

The first two or three weeks of general faradization failed to produce any marked change, simply giving for a few hours a very agreeable sense of rest.

This was attributed entirely to the fact that the patient exerted himself too much to receive the treatment, as he was compelled to ride several miles to our office.

As soon as the apparatus was transferred to his own house and the treatment administered there, improvement began immediately, and progressed with great rapidity, so that by the sixteenth week of the sequelæ of the disease, all paralysis, except, perhaps, the cardiac, had disappeared. Vision became entirely normal before the anæsthesia and paralysis of the limbs had disappeared. Disagreeable twitchings of the muscles of the thorax and abdomen persisted for several months, and slight cardiac feebleness remained for some fifteen months. The prospect that the patient could again engage in labor within any reasonable period had been considered exceedingly unfavorable. A very few weeks of treatment by general faradization, rendered him easily equal to the details of an active practice.

Dr. Dahlerup describes a case of cardiac paralysis occurring in a lad who was recovering from a diphtheritic attack.

The action of the heart became very rapid, but irregular and weak. Dyspnœa was present, together with cyanosis and orthopnœa, but the area of cardiac dulness was not increased.\* Some improvement followed the administration of stimulants combined with digitalis, but at the end of a week the patient collapsed and died. Although the case was said to be one of *progressive* diphtheritic paralysis of the heart, it is not difficult to believe that the prompt and proper use of electricity might possibly have saved life.

*Cerebro-Spinal Meningitis.*—The symptoms that follow an attack of cerebro-spinal meningitis, differ very widely both in character and gravity. We may have first, incurable organic changes resulting on the one hand in total blindness and entire loss of hearing, and on the other, in a condition well illustrated by the following case which we saw for Dr. Roosa some years since.

*Probable organic changes following cerebro-spinal meningitis.—No benefit.*

CASE CLXXXIII.—In 1865 the patient was attacked by acute cerebro-spinal meningitis. After convalescence he gradually regained a fair degree of physical vigor, but was left with a permanent impairment of certain phases of innervation. In conversation and in action he was perfectly rational, and his sleep was undisturbed, but during his waking hours there was ever present a sense of vacancy; “*vast and formless*” ideas troubled him; there was to him an unreality in all his surroundings. He described a vibrating shock which would at intervals seem to pass through him, leaving an impression that seemed like “*eternity.*”

The left pupil was dilated and insusceptible to light or other irritation. This patient received benefit from no form of treatment. Time has failed to do anything for him; to-day he is much the same as he was fifteen years ago.

The pathological changes in cases such as the above cannot of course be positively stated, but it is probable that they are analogous to what have been observed in certain cases of chronic basilar meningitis, viz., cicatricial changes, together with induration of the connective tissue.

Another train of symptoms following cerebro-spinal meningitis, more frequent and, fortunately, far more amenable to treatment, has occasionally fallen under our observation. The symptoms in all were quite uniform in character, and we present the following as a type of the rest.

*Aggravated symptoms persisting for two and one-half years after an attack of cerebro-spinal meningitis.—Recovery under central galvanization.*

CASE CLXXXIV.—On May 20, 1872, Mrs A—, aged 42, was prostrated by

\* British Medical Journal, September 27, 1879.

an attack of cerebro-spinal meningitis. It might be interesting to detail its acute course, but for our purpose it will suffice to say that the case was exceptional in its duration and severity. For six months she was confined to her bed, suffering from almost every conceivable symptom associated with this disease. She was at first under homœopathic treatment, but subsequently came under the care of Dr. A. S. Heath, of this city, who attended her up to the time our advice was sought, April 10, 1875. Two years and a half had elapsed since the more acute stage of the disease had subsided, during which time she had submitted to various forms of treatment that were apparently wise and judicious, without the least improvement, and until the ordinary methods seemed exhausted. She was able to be about her house and occasionally went out, but she suffered without cessation from severe pain, which, beginning in the eyes, was most pronounced over the back of the head and neck, and extended to the lower cervical vertebræ. The painful muscular stiffness of the neck, from which she had suffered so terribly during the acute attack nearly three years previously, had never left her and was a constant cause of distress. No posture was endurable except when the head was thrown back, while, during occasional paroxysms of more than ordinary severity, these muscular contractions would become convulsive. These symptoms, together with others, and especially with a chronic irritation of the intestinal tract from the mouth to the anus, incapacitated the patient for all enjoyment and the ordinary duties of her station. For the symptoms more directly due to the meningitis, we submitted the patient to central galvanization; as a general tonic, and for the relief of her digestive difficulties due to intestinal irritation we employed general faradization. Up to June 25, 1875, a period of ten weeks, fifty applications were administered. Under this treatment alone the patient steadily improved, and when she left the city for the summer months she was, to a great extent, relieved of the most distressing symptoms. Upon her return treatment was resumed until complete recovery. We say complete recovery. This statement should perhaps be modified. At this date she feels an occasional aching, and a slight drawing sensation at the back of the head after much fatigue, but in general she has all along enjoyed a fair degree of health.

In this connection we may be permitted to call attention to the fact, that sudden blows and shocks may in certain cases result in obstinate circulatory derangements of the cerebro-spinal tract, associated with symptoms analogous to those following cerebro-spinal meningitis.

The above statement was very strikingly illustrated in the person of a lady sent to us a few years since by Dr. J. Ellis Blake.

CASE CLXXXV.—Some five years before she had fallen upon the sacrum—the immediate effects of which were severe pain, nausea, and slight motor paralysis of the extremities. Recovery seemed complete in a few weeks, but shortly after, on taking a severe cold, the same symptoms returned, and then, with the exception of some slight traces, gradually disappeared. Two years before we saw her she fell again, striking on the hip with such force as to cause an aggravation of all the symptoms before experienced, together with a peculiar perversion of vision. All *dark* objects appeared *red*, and it was some time before sight became natural in this respect. For a time she suffered from excessive hyperæsthesia, which, on subsiding, was followed

by cephalalgia. The pain was specially localized over the mastoid processes, back of the head and neck, with frequent extension along the entire length of the spinal cord.

The patient carried her head at all times slightly thrown back, and in attempting to throw it forward complained, as do patients suffering from the sequelæ of cerebro-spinal meningitis.

She suffered much from insomnia, and was capable of but little exertion. From June 11 to August 1, 1877, the patient was subjected to central galvanization, receiving in this time thirty-seven applications, which to a great degree dissipated the more prominent symptoms from which she had suffered for years. In the spring of 1879 she complained of marked evidences of a return of the old symptoms. The same method of treatment was employed as before, resulting, in less than three weeks, in complete relief.

*Typho-Malarial Fever.*—When we come to consider the sequelæ of either typhoid or malarial fevers, we shall not, as a rule, find the same gravity or diversity of symptoms that often confront us subsequent to the acute stages of diphtheria and cerebro-spinal meningitis.

Convalescence is, however, occasionally very tedious, and we have recorded not a few such cases where the tonic effects of general faradization, in hastening returning strength, were most distinctly marked. The symptoms that followed the subsidence of the fever, in the case here given, were not only serious and obstinate in character, but so entirely unique, that they seem to us to be well worthy of record.

CASE CLXXXVI.—Mr. S—, aged 23, was taken ill in June, 1879, by an acute attack of dysentery, followed by typho-malarial fever. In six weeks the fever passed away, leaving the patient quite helpless. With returning strength he was able to leave his bed and go into the country, in the hope that there the convalescence would be more rapid. He gained very little in power over the movements of the limbs and body, and when we saw him the following September, through the kindness of his physician, Dr. J. O. Farrington, of Harlem, the phenomena present were both unique and grave.

It may, perhaps, convey a fair idea of the general appearance, to say that the whole body was thoroughly stiff. The legs from the hips down, could be moved only with difficulty. The arms could be raised from the sides but a little way. The head and neck were almost motionless upon the shoulders. The right shoulder could be moved slightly up and down; the left not at all. Deglutition was so much impaired that solid food could not be taken with comfort or safety.

There was much wasting of the muscular tissue, but this was most apparent in the right thigh, which had decreased several inches in circumference, and in the posterior portion of the neck on either side, where the trapezius muscles immediately below their occipital origin had atrophied to an alarming extent. It was found, on submitting the patient to an electrical examination, that the farado-muscular contractility of every superficial muscle, with the exception of the abdominal, was very greatly impaired. The right trapezius contracted slightly to a powerful current, but the left trapezius failed to react to any stimulus. The sterno-cleido-mastoid muscles, when

are normally so susceptible, contracted only under the influence of a very powerful current. There were no sensory or other symptoms present especially suggestive of serious central disease, but a strength of current ordinarily unendurable could be applied to the back of the neck without producing any sensation whatever. Localized faradization or galvanization in a case such as this, where almost every muscle was involved, would have been manifestly impracticable.

The case called for an impression more general and powerful than can possibly be obtained from mere localization of currents. General faradization was therefore attempted, and with results that confirm the abundant testimony that has already been given of its remarkable efficacy.

The affected muscles developed with astonishing rapidity. Deglutition improved immediately, and soon became natural. After a few applications, returning sensibility and contractility to the influence of the current became manifest. Improvement rapidly went on until all atrophy having disappeared, and the head, neck, and limbs becoming quite flexible, the patient was able to resume an active and laborious mercantile position.

Although the differential indications for the use of the two currents in the sequelæ of the diseases under consideration have been made more or less apparent in the preceding illustrative cases, it may be well to concisely formulate them as follows :

1st. For the relief of the various paralytic symptoms that follow diphtheria, whether cardiac or of the voluntary muscles, the faradic current is almost always, if not invariably indicated.

2d. The galvanic current here is not only less effective than the faradic, but is frequently useless, and occasionally harmful.

3d. While localized faradization may prove sufficient in cases where the symptoms are mild and restricted in extent, general faradization should be used where the paralysis is more general and constitutional symptoms are manifest.

4th. In the treatment of the sequelæ of cerebro-spinal meningitis the galvanic current, and generally by the method of central galvanization, is indicated.

5th. For these and analogous symptoms relating to the central nervous system, the *true* constant current, or, in other words, of so-called low tension and increased quantity, are preferable to the ordinary continuous current of higher tension.

*Sequelæ of Sunstroke.*—During seasons of protracted and excessive heat, such as have been notably experienced during the past few summers, a very large number of persons, especially in our cities, are more or less injured, either by the general depressing influence of the continued high temperature, or by some special exposure, without being, in the ordinary sense of the word, *sunstruck*. Those whose nervous system

has been exhausted or disordered by the excessive use of stimulants and narcotics, by debilitating diseases, and especially by overlabor or excitement of the brain, are most liable to be thus affected.

Injuries thus produced may be manifested by every variety of nervous disorder—spinal irritation, insomnia, neurasthenia, neuralgia, epilepsy, nervous dyspepsia, hysteria, paralysis, and, not unlikely, positive insanity.

The majority of such cases never know the exciting cause of their symptoms until, perhaps, it is indicated to them by the physician who inquires into them. In a number of cases that have been under our care for the above symptoms the solar heat was a prominent if not a principal cause.

The symptoms may appear and reappear for months and years after the original attack. There is little doubt that there are through society thousands of such cases of various grades, many of whom have never suspected the nature of their malady. The solar origin of the symptoms which we have mentioned may be suspected not only when, as is very frequently the case, they can be traced to some definite exposure, but also when they are observed to be peculiar to the summer, remitting wholly or partially in winter, or to be especially aggravated by exposure to the sun, and to be experienced only during the daytime.

Our best results with electricity have been obtained in these cases by a combination of the two methods of electrization, general faradization and central galvanization, varied in some cases by galvanization of the pneumogastric and cervical sympathetic. Excepting those cases which, by some peculiarity of temperament, or as a peculiar result of the disease, cannot bear electricity, the electrical treatment works admirably, whether used alone or in connection with internal medication. Arsenic we give in the form of granules,  $\frac{1}{10}$  of a grain each, before meals. We use also zinc in the form of oxide or phosphide, and fat in the form of cod-liver oil emulsion.

*Partial paralysis—Physical and mental depression—The sequelæ of sunstroke—Rapid recovery under general faradization and central galvanization.*

CASE CLXXXVII.—Mr. W., aged 55, consulted us in the autumn of 1872. The patient was connected with one of the prominent firms for the manufacturing of safes in this city; and while in a western city, endeavoring to negotiate certain sales, he was suddenly overtaken with faintness, profound vertigo, and almost complete unconsciousness. This attack occurred on an oppressive July day, some four months prior to his visit to us, and ever since he had been in an exceedingly nervous, excitable condition. Any considerable exercise in walking was invariably followed by unusual fatigue, and he was not only incapacitated from engaging in any business enterprise,



but an attempt to read even the morning paper resulted in mental disquietude and real exhaustion. There was a decided loss of power in both lower extremities, associated with a considerable degree of anæsthesia. We submitted him, on several different occasions, and at intervals of a day, to general faradization, with the effect of improving greatly his motor power and of dissipating all numbness. After a time central galvanization was alternated with the above treatment, and in the course of six weeks the patient had so far improved in his other symptoms as to be fully able to again engage actively in business.

In the following case the peculiar susceptibility to stimuli caused by sunstroke was strikingly illustrated:

CASE CLXXXVIII.—Mr. W., a gentleman about 35 years of age, was referred to us, October 16, 1872, by Dr. A. B. Ball. While ascending a mountain during his summer vacation, he was overcome by the excessive heat. He was not unconscious, and after a short rest he resumed his walk. The thermometer at the time was about 90°.

The attack left him with a feeling of sensitiveness in the head, which, instead of diminishing, had increased until the time that he called upon us. During several weeks, at intervals of a few days, he had several attacks of loss of motor power.

A prominent feature of his case was his exceeding susceptibility to stimuli. A teaspoonful of wine or a whiff of a cigar caused him to feel wretchedly.

We found him on trial similarly sensitive to electricity. Mild faradization or galvanization caused a heightening of the evil symptoms, and the electrical treatment was abandoned. Subsequently the patient was rapidly benefited by a short trip to the seaside. The first breath of the ocean air seemed to act on him with the force of a specific.

## CHAPTER XXXVIII.

### MISCELLANEOUS MEDICAL DISEASES.

*Intermittent Fever.*—According to Tripier\* the electric bath and statical electricity have been used in certain cases of intermittent fever, both in England and Sweden, and occasionally with satisfactory results. The efficacy of the preparation of quinine in malarial disease has, however, destroyed most of the interest that might otherwise have attached to electricity in its therapeutic relation to fevers.

In certain *chronic* conditions of intermittent fever, where quinine and other internal medication have proved unavailing as a means of permanent relief, we have seen undoubted benefit arise from *general* faradization. It undoubtedly acts in this case like any other stimulating tonic without any special influence on the malarial poison.

*Intermittent fever—Temporary relief from quinine—Recovery under general faradization.*

CASE CLXXXVIIIa.—Rev. Mr. L. applied to us for treatment in October, 1867. His general appearance presented all the marked characteristics of malarial influence, while he complained of obstinate constipation, loss of appetite, and a considerable degree of insomnia. One year previously he was prostrated by an attack of chills and fever, but soon recovered his usual health under the influence of quinine. In the following July he suffered another and more severe attack of the tertian, which soon changed into the quotidian type of the disease. During the first ten days of his illness he took 100 grs. of quinine, but with little apparent benefit. Still further treatment by quinine interrupted the severity and regularity of the paroxysms, but by no means effected a cure. For some time before he fell under our observation (Oct. 14, 1867), he suffered every few days from what is commonly termed "dumb ague." We immediately resorted to the most thorough form of treatment by general electrization with the faradic current. He was remarkably susceptible to its influence, and over the region of the stomach and liver especially only a very slight current could be borne.

This treatment was repeated every other day for two weeks. His bowels soon became regular, his appetite improved, and after the third application the attack ceased altogether. For several months, at least, after the cessation of treatment he continued free from any indications of returning symptoms. Subsequently he passed from under our observation.

\* Manuel d'Electrothérapie, etc., 1861, p. 581.

A second and third case, in which the symptoms were less severe, but fully as persistent, yielded promptly and completely to the same method of treatment.

*Intermittent fever associated with anæsthesia, insomnia, and great debility—Approximate recovery in two weeks by general faradisation.*

CASE CLXXXVIII<sup>b</sup>.—Miss C. S., aged 23, was placed under our care by Dr. Geo. Steinert, of Harlem.

The patient had all her life been somewhat feeble in health, but at this time, and for a month previously, she had suffered from a very decided impairment in her general condition.

Every afternoon at 4 o'clock she experienced a very decided sense of chilliness, followed by a fever which lasted until 5 o'clock the following morning. The hands were at all hours exceedingly tremulous, and at night especially her fingers became quite anæsthetic. Her strength was so far exhausted that she could walk but a few blocks without great fatigue. Notwithstanding these unfavorable symptoms her bowels continued regular and her appetite good.

She suffered much, however, from insomnia, and was rarely able to sleep before 2 A. M.

A single general application of the faradic current resulted in marked relief of the condition of trembling and numbness. Her sleep rapidly improved; the periodical chill and fever became less and less marked, and soon disappeared; her strength decidedly increased, and seven applications given during two weeks resulted in an approximate recovery.

*Disease of the Supra-renal Capsules (Addison's Disease).*—Our knowledge of the pathology of Addison's Disease is very incomplete. In a large proportion of cases the bronzing of the skin and the peculiar cachectic condition of the affection are preceded by organic lesion of the supra-renal capsules.

Cases are not wanting, however, in which *post-mortem* examinations have revealed no anatomical lesion of the capsules, notwithstanding the previous existence of the most marked and severe characteristics of Addison's disease.

Dr. Wilkes states, "That after some years' attention to the subject, I repeat, with much confidence, that the disease of the capsules in *Morbus Addisonii* is uniform and peculiar. In all the examples which we have now in our museum, amounting to thirty-three, the disease is of the same nature in all." †

Of one hundred and ninety-six cases reported by Dr. Greenhow, the

\* Guy's Hospital Reports. Vol. xi., 1865. Quoted from Aitken's Practice of Medicine. Vol. ii., p. 113.

supra renal capsules were found to have undergone the characteristic morbid change in one hundred and twenty-seven.\*

In consideration, therefore, of these facts, it is extremely probable that certain organic changes in the capsule of the kidney, and the peculiar symptoms of the disease under consideration, are directly related to each other as cause and effect. If the affection be recognized before the bronzing of the skin has taken place, it may possibly be arrested.

Unfortunately, however, it is, as a rule, impossible to diagnose the disease before the discoloration of the skin commences, when it is generally acknowledged to be incurable.

In regard to this bronzed discoloration of the skin, microscopical examinations by Dalton and others, have demonstrated that it is due to pigmentary granules in the rete mucosum, similar to those in the skin of the negro.

We give the following details of the remarkable effects of electricity in a case of Addison's disease exactly as they appeared in the first edition of this work. After the patient had approximately recovered his strength, he was presented before the New York Medical and Library Association, by Dr. Rockwell, as an illustration, not as a *cure*, of a case of disease of the supra-renal capsules, but as one of the very best illustrations of the extraordinary tonic powers of general faradization.

Most of those present acknowledged the amelioration of the man's symptoms to be the result of the treatment, but doubted whether there was or had been disease of the capsules. For two years afterwards the patient lived and enjoyed during the time all the vigor that had resulted from the use of electricity. Suddenly, and without apparent cause, his strength failed him, and within twenty-four hours he died. A post-mortem was obtained which substantiated the original diagnosis. The capsule of one kidney had entirely disappeared, leaving in its stead some calcareous remains. The other capsule was situated on the internal border of the kidney a little below its normal seat, and was composed of a cheesy-like substance—characteristic of the disease.

The specimen was presented by Dr. Rockwell before the members of the New York Pathological Society.

*Disease of the supra-renal capsules—Dark skin—Deficient secretions—Paralysis of the left arm—Loss of sexual power—Very great improvement under general faradization—Slight further improvement under galvanization of the sympathetic.*

CASE CLXXXIX.—The patient, a man aged 45, was referred to us by Dr. H. H. Gregory, of Harlem, and the diagnosis of disease of the supra-renal capsules was confirmed by Prof. Austin Flint.

\* Clymer in Aitken's Practice of Medicine. Vol. ii., p. 110.

Until November, 1867, the patient enjoyed perfect health.

About this time he began to observe slight symptoms of exhaustion. Soon his appetite failed him. He became anæmic, and suffered from excessive fatigue after the slightest exertion.

He was confined to his bed during the month of January, when he first observed some slight discoloration of his face and hands.

During the succeeding months, until August, 1868, his general health seemed to improve somewhat, so that he was enabled to engage in moderate labor. At this time he suddenly relapsed into a state of utter exhaustion. His skin became several shades darker, and his general appearance was that of an ordinary mulatto.

His bowels became distressingly constipated. Sleep was fitful and unrefreshing. His mouth and throat were excessively dry and parched; indeed, the function of the secretory organs generally was markedly impaired.

The skin was shrivelled and dry. The finger-nails were brittle, breaking on the application of a very slight force. The left arm was stiff and almost powerless. It could not be bent beyond a right angle, nor lifted more than a few inches from the side. Lastly, the sexual power and desire were entirely lost.

All of these symptoms persisted, with but slight variation, notwithstanding an uninterrupted tonic treatment, until June, 1869, when the case fell under our observation. As the most prominent and distressing symptom of which the patient complained was the excessive debility that unfitted him for the slightest exertion, the results of treatment by general electrization illustrate more forcibly than in most other instances its remarkable constitutional tonic power. A general application of the faradic current revealed not only a profound anæsthetic condition of the whole body, but also an unusual general impairment of the electro-muscular contractility. By placing the negative electrode at the pit of the stomach, and the positive on the neck, a little above the seventh cervical vertebra, distressing nausea was invariably produced.

The patient began to amend from the first day of treatment, and, after having received thirty general applications of the faradic current, his condition at that date may be thus summed up:

- 1st. He had long been completely cured of his constipation.
- 2d. Sleep was perfectly sound and refreshing.
- 3d. The dry and parched condition of his mouth and throat was entirely relieved, and all the secretions of the body had increased in quantity and quality.
- 4th. His finger-nails were restored to their usual elasticity.
- 5th. He had approximately recovered the use of his arm. This improvement was manifest after the third application.
- 6th. The sexual organs had been very decidedly strengthened.
- 7th. Above all, his strength and power of endurance had progressed with the above changes. At first he was barely able to crawl a single block; he could afterwards walk a couple of miles without suffering unpleasant fatigue, and could readily engage in any light labor.
- 8th. In regard to the bronzing of the skin, the change was not, as yet, very marked. The discoloration seemed to be a shade lighter, and had sensibly receded on the sides of the fingers and hands.

We have referred to the nausea excited by the electric current. In

view of certain theories that have been advanced concerning Addison's disease, this fact is of considerable interest.

The semi-lunar ganglion and solar plexus, and also the pneumogastric and phrenic nerves, supply nervous filaments to the capsules.

In consideration of this fact, Dr. Habershon and others are of the "opinion that the more fully the disease is known the more completely will it be traced to the sympathetic nerve." The unusual action of even a mild current on that nerve, in producing nausea, tends to strengthen this conclusion.

This annoying symptom rapidly became less marked as the patient gained strength under the influence of electrization, and a most powerful current could soon be applied without causing inconvenience.

The patient was subsequently treated by galvanization of the sympathetic, with some further, though not marked, improvement.

Very little scientific attention has been given to the electrotherapeutics of diseases of the kidneys, although the organs are sufficiently accessible to electrization. Most of the recognized chronic diseases of the kidneys are of so grave a character that they have offered but little encouragement for electrical experimentation.

It is impossible to pass an electric current through the body in the region of the kidneys without directly affecting these organs, as is clear from what is known of the conductivity of the tissues, and also from clinical observation. In many instances patients have called our attention to the fact that after general faradization the secretion of urine was much increased.

*Complete suppression of urine for six days, following an attack of gravel—Three applications of general faradization is followed by a copious flow, amounting in eighteen hours to over twelve quarts.*

CASE CXC.—Mr. S., aged about 50, and weighing some 280 lbs., had for several years suffered more or less from gravel. In these paroxysmal attacks the urine would often become completely suppressed, but by a warm bath and warm drink the functional activity of the kidney invariably returned in a short time. On one occasion, however, after an attack of unusual severity, these ordinary remedies completely failed to re-establish the excretion of urine. Dr. H. H. Gregory was immediately called, and, in conjunction with Dr. W. H. Draper, vainly endeavored by every means at command to relieve the suffering patient. At the end of the sixth day but about thirty drops of a thick and bloody fluid had been passed, and Dr. Gregory requested us to use electricity. The patient was at this time completely prostrated and very drowsy, but no odor of urea could be detected in the breath. We decided to submit the patient to general faradization, and on Saturday evening, the sixth day of the suppression, made a preliminary attempt. There was so much adipose tissue to overcome, and the skin of the patient was so exceedingly sensitive, that it was very difficult to carry out the

proposed treatment effectually. On Sunday morning a second application, with an increased strength of current, was given, and again on Sunday evening at 10 o'clock the treatment was essayed a third time. Two hours subsequently the patient felt a desire to urinate and succeeded in passing an ounce. In a few minutes the desire to urinate returned, when almost without cessation he passed an ordinary sized chamber full, and up to six o'clock the same day twelve quarts were voided. From this time forth the kidneys continued active, and the patient recovered.

An instructive feature in this unique and interesting case lies in the fact that, notwithstanding a complete suppression for 168 hours, the symptoms of uræmic poison were by no means so decided as might be expected. This amelioration can without doubt be fairly attributed to the skilful management of the attending physician, especially in the matter of hot-air baths, by which the excretory function of the skin was kept in a constant state of activity.

In relation to the credit due to electricity for the successful issue of this desperate case, whether the symptoms were self-limited, or whether the treatment by the hot-air baths and internal medication would alone and in good time have brought about the desired result, it is impossible positively to decide. On the principle of *post hoc et*, etc., it would certainly seem as if faradization should be regarded as the important therapeutic factor employed, especially as its power to increase the urinary secretion, both in the healthy and diseased condition of the kidney, is clearly taught by experience.

*Diabetes.*—The supposed relation of this symptom to the disease of the brain suggests the propriety of treating it by *galvanization of the sympathetic and of the brain and spinal cord.*

Dr. Wm. Dickinson,\* who has made post-mortem examinations of the brain and spinal cord of five diabetic patients, found the following peculiar morbid changes, which were nearly similar in all:—

1. Dilatation of the arteries. This was the earliest symptom.
2. Degeneration of the nervous matter.
3. Cavities produced large enough to be seen without the microscope, and which contained products of nervous decay.
4. These contents become absorbed.

These changes were found near the arteries and throughout the spinal cord and encephalon, but especially in the medulla oblongata and pons varolii.†

\* Medical Times and Gazette, March 19, 1870.

† The relation which has been established by Calvi between diabetes and pruritus of the vulva, which is a nervous affection, would seem also to speak for the nervous character of the former disease. (See Damon's Neuroses of the Skin, 1868, p. 25.)

These investigations were confirmed by a most distinguished author in nervous pathology, Dr. Lockhart Clarke.

Besides these pathological observations, there are two general considerations which might be adduced in favor of the theory that diabetes is essentially a nervous disease.

In the first place, it appears, in some instances at least, to be brought on by excessive mental excitement or worry. That it may be produced by concussion of the brain is, we believe, conceded. That there is a relation between diabetes and the base of the brain has for some time been more than suspected.

Secondly, the results of some of the therapeutical measures would seem at least to indicate that this disease may be favorably influenced through remedies that affect the nervous system. Prof. Austin Flint\* has recently published reports of two or three cases of diabetes that were decidedly benefited by bromide of potassium.

Experience is the best and only test of the strength of these facts and considerations. The experiment of central galvanization—including the brain, spinal cord, and sympathetic—is surely worthy of a faithful trial, especially in the early stages of this affection. This treatment would be none the less indicated if, as some suppose, the pathological changes found in the brain and spinal cord of diabetic patients are merely the *result* of the disease.

Experimentally faradization of the liver might also be tried.

Semmola † has found both temporary and permanent results from faradization and galvanization of the pneumogastric. In some cases both the quantity of urine and of sugar were diminished. It may be remarked that it would be difficult to galvanize the pneumogastric without also affecting the sympathetic.

It is yet too early to offer positive opinions in regard to the electrotherapeutics of this disease, but the following cases are suggestive of what may possibly be accomplished in the future.

*Diabetes Mellitus of traumatic origin in an aged patient—Rapid relief of all the symptoms, and apparent arrest of the disease under central galvanization—Subsequent attack of hemiplegia.*

CASE CXCI.—J. D., a farmer, aged 76, was referred to us January 30, 1873, by Dr. J. H. Raymond. The patient had always been active, laborious, and well, until two years previous, when he fell ten feet in a barn, struck and hit on his side. That same night came pain in the nipple, and a very profuse flow of urine. At one time he passed as high as two quarts and three pints daily. It was ascertained that the

\* American Practitioner, Jan., 1870.

† Quoted by Althaus, *op. cit.*, p. 582.



urine contained sugar, and by medical advice he had adopted Camplin's diet, and under Dr. Raymond had taken carbonate of soda with advantage.

The symptoms at the time the patient came to us were as follows:—There was headache, bad taste in the mouth; the urine had a specific gravity of 1024, and he was obliged to rise in the night to pass water; about two quarts were passed daily; there was considerable muscular debility, so that a short walk was fatiguing.

On the theory that the disease was in the spinal cord, or at least in some part of the central nervous system, we began to use central galvanization, with immediate results. After the first application he began to be stronger, and after a week it was no longer needful for him to rise at night to pass water. The specific gravity of the urine soon went down to 1019, at which point sugar could still be detected. The diet of the patient, and his general manner of life, were the same as before. Sugar was never entirely expelled from the urine, but in strength the patient so much improved that he could walk several miles daily. The headaches were felt no more, and the bad taste was much mitigated. He returned to his home and to his occupation, and was able to work more or less for six months, when he was taken with hemiplegia.

Dr. Bunker informs us that he has similarly treated a case of diabetes, and has from time to time examined the urine and estimated the quantity of urea. He has confirmed the experience above recorded; and besides, has shown what we did not attempt, that the quantity of urea diminished very markedly under the treatment.

In the following much severer case the apparent results of treatment were less decided:—

*Diabetes mellitus, two and a half years' standing, apparently caused by a fall, complicated with various nervous symptoms—Temporary benefit from central galvanization.*

CASE CXCI.—Mrs. L., a married lady, under middle age, was sent to us March 4, 1873. Two and a half years before she had a severe fall, which produced a concussion of the spine, and laid her up for a week. In a few months came on excessive thirst, constipation, and sugar in the urine. She had been through various forms of treatment, and confined herself to bran-bread, and was then drinking Bethesda water, which seemed to do her good. Her condition was as follows: Specific gravity of urine, 1049; six gallons passed daily part of the time, and when she paid no regard to her diet. Considerable facial neuralgia, great thirst, a feeling of aching and stiffness in legs, with pains resembling growing pains; insomnia, partly owing to the fact that she was obliged to get up several times during the night to pass water; and tenderness of dorsal and lumbar vertebræ. Treatment by central galvanization faithfully used brought down the specific gravity of the urine to 1040, but never lower than that, enabled her to pass the entire night without rising to make water, and relieved many of her general nervous symptoms, and this was all it accomplished.

*Cirrhosis of the Liver.*—The pains that accompany this disease may be relieved by various electrical applications, and it is possible that the disease might be arrested, in some cases at least, provided the treat-

ment was began early and faithfully carried out. We have known one case to be somewhat benefited in this way.

*Dropsical Effusions.*—Dropsical effusions are susceptible of treatment by the electric currents, even when they depend on incurable diseases of the heart, liver, or kidneys. Galvanization and faradization may both be tried with strong currents.

In œdema of the lower limbs we have found both galvanization and faradization temporarily and sometimes permanently efficacious.

*General dropsy the result of valvular heart disease*—Powerful faradic currents, localized, greatly increase the secretory action of the kidneys, and dissipate the dropsical effusion.

CASE CXCI.—December 13, 1870, we were called to see, with Dr. Samuel T. Hubbard, a lady aged about thirty-five years, who was suffering from general dropsy. The abdomen was enormously distended, and the lower limbs were double their normal size. The patient was a frail, delicate woman, and for years had suffered from valvular disease of the heart resulting from articular rheumatism.

The kidneys were almost entirely inactive, so that she voided not more than a teaspoonful of urine at a time, and the aggregate quantity secreted during twenty-four hours was but a trifle. All that we could hope to accomplish was to whip up the secretory process, and for this purpose a faradic current of great intensity was directed through both kidneys and the lower limbs. The current was to the patient hardly appreciable, notwithstanding the great strength of current used, and yet the flow of urine was so increased that during the next twenty-four hours a greater amount was voided than she was accustomed to pass when in her ordinary health. The applications were repeated fifteen times (the increased amount of urine secreted being kept up) until the water had disappeared from the abdomen and legs. This was only one of several previous attacks, and her strength was so much reduced by continued suffering that she gradually sank and died. Electrization evidently prolonged life, and by relieving the pressure on the lungs, much alleviated the distress.

*Bright's Disease.*—Theoretically, local galvanization through the region of the kidneys and central galvanization ought to be of service in the early stages of Bright's disease. The nutrition of the kidneys might thus be improved directly and indirectly.

We have not yet experimented as much in this direction as we could wish.

Dr. H. J. Pratt, of Denver, Colorado, reports a case of Bright's disease where the galvanic current applied over the dropsical abdomen and general faradization resulted in relief of the dropsy, and in a diminution of the amount of albumen and of the hyaline casts.

*Rhinitis (Catarrh).*—Subacute and chronic inflammations of mucous membranes are susceptible of electrical treatment—may, indeed, be permanently as well as temporarily relieved by it, though but rarely does it work an entire cure unless aided by other measures.

Aside from any chemical effect of the current, its mechanical action alone would be sufficient to theoretically account for the relief it gives to inflamed mucous membranes. Stellwag, speaking of irritants in general in the treatment of external inflammations of the eye, uses the following language : "The irritation which they set up in the sensory nerves being carried over to the vaso-motor nerves, may cause a contraction of the calibre of the vessels when they are in a condition of relaxation. This is done by the excitation and invigoration of the atonic muscular fibres. The resolution of the inflammation is favored by the lessening or removal of the congestion, which is one of the causes of the unfavorable course." \*

The theory is fully plausible that electricity operates to a less degree in the same way, for its primary effect is to increase the amount of blood in the mucous membrane to which it is applied, and experience shows that this hyperæmic condition thus created soon passes away. †

The same explanation will apply to the action of electricity on all the mucous membranes—the eye, the ear, the pharynx, larynx, and urethra. Certainly the ultimate result of electrization is to give tone to the mucous membranes as to other tissues of the body. (For methods of treatment of rhinitis, see *Anosmia*.)

*Catarrh of eight years' standing—Complete and permanent recovery under local galvanization.*

CASE CXCV.—Mr. N., aged 28, was referred to us by Dr. D. B. St. John Roosa. For eight years the patient had been afflicted with nasal catarrh, of a most persistent and annoying type. We expressed doubt as to the efficacy of the electrical treatment in her case, and stated that if it was undertaken it would be necessary to be most persevering in order to test its efficacy.

The patient was willing and anxious to try this or any other method that offered the slightest chance of relief, and for nearly four months she submitted to the proposed treatment. From four to six ordinary sized zinc-carbon cells were used, and the treatment was both external and internal. About sixty applications were given, and the result was a complete recovery.

Over four years have now elapsed since this case was first published, but the patient has never felt a symptom of a return of the difficulty.

*Anosmia, or Loss of Sense of Smell.*—A very frequent result of long-continued rhinitis is partial or complete anosmia. The acute form that

\* Diseases of the Eye. Translated by Drs. Hackley and Roosa, p. 26.

† Golubew has shown that the capillaries of the nictitating membrane of the frog contract transversely under the influence of powerful electrical shocks. (Billroth's Surgical Pathology. Translated by Dr. C. E. Hackley, p. 53.)

appears in the early stages of severe cold usually passes away without treatment on the subsidence of the inflammation. In some cases anosmia is supposed to, and probably does, result from careless and too prolonged use of over-irritating injections. There are various grades of the disease, from simple and scarcely perceptible obtuseness of the smell to absolute inability to detect any odor whatever. Kerosene, coffee, illuminating gas, make no more impression than substances of a negative character.

Anosmia may also result from central as well as peripheral lesion.

The *treatment* of anosmia may be both external and internal. The external treatment is the same as that recommended for rhinitis, except that the current should be much stronger; the internal treatment consists in the direct application of a metallic electrode to the mucous membrane of the nasal passages. We have used for this purpose an insulated electrode, with a metallic bulbous extremity that can be run some distance up the inferior meatus. An insulated Eustachian catheter, containing a wire with a bulbous extremity, serves very well the purpose, or a common silver catheter, uninsulated, may be used; or, indeed, any flexible metallic electrode of proper size.



FIG. 136.  
Nasal Electrode.

*Anosmia existing six years—Improvement under treatment by local faradization.*

CASE CXCIV.—Mr. H. I., a medical student, aged 30, was referred to us by Dr. Roosa, May, 1869. Some six years previously the patient had fallen from a horse and sustained severe bruises about the head and face. From that time he had been unable to distinguish any odor with the exception of that of fresh-ground coffee and kerosene oil.

A powerful application of the faradic current was made on either side of the bridge of the nose, near the eyes, enabling him in the course of a few hours to smell faintly certain strong perfumes.

On the following morning, however, he was surprised to find himself able to smell tobacco smoke, camphor, etc.

His sense of smell remained thus acute until three or four in the afternoon, when it suddenly disappeared.

A second application was followed by the beneficial result of the first, and with only a partial relapse, while the third and fourth séances rendered him sensible to most of the ordinary odors.

*Anosmia associated with loss of the sense of taste—Recovery under localized galvanization.*

CASE CXCVI.—Mrs. H., sent to us by Dr. A. N. Brockway, aged 45, was suffering from a severe and chronic nasal catarrh, and associated with this disease was a complete loss of the senses of taste and smell.

It was alike to the patient whether she ate the most delicate morsel or the driest crust, or whether she inhaled the perfume of the rose or the most disagreeable of odors. This condition has existed for several years, but under the influence of the galvanic current, applied both to the mucous membrane of the nasal passages and externally, the senses of taste and smell gradually returned to their normal acuteness.

*Toothache (Odontalgia).*—The pathological conditions that give rise to toothache are so various, and the anatomical difficulties in the way to direct localization of the current in the affected nerve are so great, that no uniform results from electrical treatment cannot be expected.

The familiar cause of toothache is exposure to cold. Although the nerves connected with decayed teeth are more liable to be affected after such exposure, yet the nerves of any or of all the teeth, even when they are perfectly sound, may also become hyperæsthetic and cause exceeding distress, either from exposure to cold, or from anæmia or nervous exhaustion.\*

The applications may be *external* or *internal*, either with the faradic or galvanic currents. The galvanic is preferable, since by it we can better put the irritable nerve in a condition of anelectrotonos (see p. 281). Externally a moistened sponge electrode connected with the positive pole may be applied for a few minutes over the seat of the pain, while the other is held in the hand of the patient.

The application may be made internally by means of a small insulated electrode, with a metallic extremity. (The nasal or laryngeal electrode will serve the purpose.)

In both the external and internal applications it is well to begin with a mild current, and gradually increase it up to the point where the patient can conveniently bear it.

*Ozone and Ozonized Oxygen.*—When sparks of electricity pass between two metallic plates, a peculiar odorous principle is developed, which has been termed *ozone* (from  $\omicron\zeta\omega$ , to smell). This odor is observed during experiments with apparatus for statical electricity, while the electricity is passing from a point, when a discharge from a strong battery is sent through a number of sheets of paper, and also after an object has been struck by lightning. As long ago as 1785, Von Marum observed that electrified oxygen gave forth an odor much like that which is observed after a lightning stroke. This odor was usually described as “sulphurous.” Mr. Schönbein, who, in 1840, first called formal attention to ozone, first discovered that it appears at the positive pole in the electrolyzation of water.

\* Frommhold gives an interesting chapter on *Odontalgia Rheumatica*. See his *Electrotherapie mit besonderer Rücksicht auf Nerven-Krankheiten*, 1865, p. 404.

The observer also found that this peculiar odoriferous principle can be preserved in glass vessels for a very long time. The odor may be prevented from appearing by raising the temperature of the liquid to a boiling point, and it may be at once neutralized by the addition of quite small quantities of pulverized charcoal, tin, zinc, iron, lead, antimony, bismuth, or arsenic, by a little mercury, or by introducing into the substance red-hot platinum or gold. It is produced by the slow oxidation of phosphorus. It is disengaged from solutions of a number of the salts, and from diluted nitric, phosphoric, and sulphuric acids.

Mr. Gann concluded, from his experiments, that this odor may be evolved from all metals, provided they are so treated as not to become oxidized or to combine with other metals.\*

*Tests.*—The test for ozone proposed by Schönbein was a paper moistened with a solution of iodide of potassium and starch. The ozone sets free the iodine and gives the starch a deep-blue color.

*General Properties.*—Ozone is active, intensified oxygen. Like oxygen, it has a powerful oxidizing action. It is about half as heavy as oxygen, and, at a temperature of 290° (Cent.), is changed back into ordinary oxygen. It is only soluble in oil of turpentine.

Ozone exists in the atmosphere in greater or less quantity, which is believed to vary with the atmospheric conditions, and to exert a definite and powerful influence on the health, although precise and satisfactory demonstration of the nature and extent of the laws of this influence is yet wanting.

According to the experiments of Prof. Schönbein, Messrs. Martiguer, Marignac, De la Rive, Becquerel, Frémy, and others, it would appear that ozone is only a peculiar form of oxygen produced by electricity—a change analogous to that which the solar rays bring forth in chlorine—and that its presence in certain quantities is essential to health. According to Dr. Boeckel, Prof. Schönbein, and Dr. Billiard, the presence of cholera or malaria is attended by the absence of ozone.† It is possible that ozone has more or less share in the variations of the physical conditions that have been ascribed to changes in the conditions of atmospheric electricity. Ozone is found to be especially abundant in the atmosphere after a thunder-storm. It is also supposed to be produced by decay and the growth of plants. It destroys the impurities of the air miasms by producing oxidation. It has been estimated that “a

\* Lectures on Electricity by Henry M. Noad, London, 1844, p. 232.

† On the Influence of Variations of Electric Tension as the remote Cause of Epidemic and other Diseases. By Wm. Craig, 1864, p. 424. See also Cornelius Fox on Ozone and Antozone, for a résumé of what is known of this subject.

volume of air containing  $\frac{1}{8000}$  of ozone will purify 540 volumes of putrid air." In the arts ozone has been utilized for bleaching and disinfecting.

*Physiological and Therapeutical Effects of Ozone.*—The physiological effects of ozone have been studied both on man and on animals. It is believed that the bracing and inspiring effect of a clear, crisp, and sparkling morning, is due in part to the great amount of ozone in the atmosphere.\* When it is held in combination with oxygen or common air, it acts much like oxygen, but more powerfully. It affects the pulse, the respiration, and the circulation, in various ways, according to the quantity taken, and the temperament of the individual. In this respect, it behaves like electricity. It has been thought that ozone is formed in the body from the contact of oxygen gas with the blood, and there are those who believe that it is absorbed with the oxygen in the air, and is carried into the blood, where it takes part in the process of oxidation.

There is a possibility, if not indeed a probability, that electricity, in its passage through the body, generates ozone in very minute quantities, through the electrolytic and other changes that it produces, and the theory, that the beneficial effects of electrization are in part due to the ozone thus generated, has some plausibility. But on all these subjects very little is known. Experiments made in the laboratory with ozone, artificially prepared, are highly suggestive. Catarrhal symptoms and attacks, much resembling epidemic influenza, are produced by long breathing air laden with ozone. It is stated that it would be difficult to distinguish between the symptoms of influenza and the symptoms of an over-dose of ozone. Experiments on animals have shown that irritation of the mucous lining of the throat and nostrils, with febrile symptoms and congestion of the lungs, may be quickly excited by breathing air containing a large percentage of ozone. If animals are, for a long time, subjected to ozone, they perish. In their susceptibility to it, however, they vary widely. A rabbit, breathing air mingled with  $\frac{1}{8000}$  of its weight in ozone, has died in two hours. Mice, breathing air about  $\frac{1}{8000}$  of ozone, have died immediately. Rats are more susceptible than guinea-pigs, and guinea-pigs are more susceptible than rabbits. Pigeons are quite tolerant of ozone, and frogs are proof against it, provided they have abundance of water. Birds are specially tolerant of this agent, as might naturally be inferred, since, in the higher strata of the air, where they fly, ozone is more abundant than near the earth.

A convenient apparatus for the inhalation of ozonized oxygen is that

\* Dr. Baldwin (Am. Jour. Med. Sciences, Oct., 1874) gives observations that oppose this theory.

of Siemen's, which consists of a glass tube lined with tin-foil leaves that are connected with the current from a powerful helix, and slightly separated from each other, so that in passing from one to the other the current is interrupted with sparks. Through this tube the oxygen passes from an iron receiver, and ozone is developed by the action of the current at its interruptions. By this apparatus fifteen per cent. of the oxygen may be converted into ozone. A glass apartment may be constructed on the same principle, in which the patient may sit for a long time and slowly breathe in a natural manner the diffused ozonized oxygen.

Dr. C. Lender,\* of Berlin, has successfully experimented with the inhalation of ozonized oxygen in the treatment of wounds, and has found that in malaria and various conditions associated with impure blood and depraved nutrition, its corrective and tonic effects are very decided. In this country the therapeutic effects of ozone have been studied by Dr. Sass, and with encouraging results.

*Antozonc.*—This, like ozone, is an active condition of oxygen, and is produced in the same way and at the same time. The fact that such a condition as *Antozone* might exist was suspected by Schönbein in 1858, and its properties have since been studied by Meissner, in 1863 and 1869.

*Hay Fever*—(*Summer Catarrh*—*Rose Cold*—*Autumnal Catarrh*.—We have recently made extensive researches in this strange disease, and have shown that the nervous system has more to do with it than has been supposed. We have treated two cases of the disease during the attack by external galvanization. In one case considerable and in the other case very decided relief was obtained. Dr. W. F. Hutchinson, of Providence, has succeeded not only in relieving, but in breaking up an attack by central galvanization.

As a prophylactic a prolonged course of general faradization or central galvanization is recommended.

*Acute Diseases*—*Fevers*—*Convalescence*.—General faradization and central galvanization might be used in acute diseases much more than they have been. When quinine, iron, etc., are used, these methods of electrization should be used both for their sedative and their tonic effects. That the pulse and temperature, when abnormally high, can be

\* Das unreine Blut und seine Reinigung durch negativ-electrischen Sauerstoff (Ozon). Also, Sauerstoff und Ozonsauerstoff, nebst ihrer Anwendung bei Verwundeten nach einem im Berliner Inhalatorium gehaltenen Vortrage. Compare also Dr. A. H. Smith's excellent paper on Oxygen Gas as a Remedy in Disease. New York, 1870.



reduced by general faradization and central galvanization we have abundantly established by many observations, and the greater tonic effects of these methods of using electricity are now conceded everywhere.

The introduction of these methods to the treatment of acute and sub-acute diseases offers a great field for enterprising general practitioners.

Dr. Glax treated thirty cases of typhoid fever by galvanization of the cervical sympathetic, and succeeded in reducing the temperature and diminishing the fever.

In *convalescence* from any acute disease, general faradization and central galvanization are a great assistance, and have been considerably used for that purpose by ourselves and other observers.

*Obesity*.—Obesity has been treated by powerful faradization, with a view to produce absorption of the adipose tissue, and, it is claimed, with some success. The applications are directed through the abdomen.

*Chronic Alcoholism*.—Without attempting to consider the many symptoms associated with alcoholic poisoning, or attempting to define the possible pathological changes that may appear in the membranes of the brain and spinal cord, we would here simply call attention to a certain impairment of motor power in the lower extremities. This loss of power simulates paraplegia, but as a rule is only partial or incomplete.

It is, however, sufficiently distinctive to deserve the term of "alcoholic paralysis," and is indicative of a condition more rooted and severe than the familiar general muscular and nervous debility that afflicts the habitual drinker. While in many cases of alcoholic paraplegia it is evident that certain pathological peculiarities must exist, such as chronic meningitis of the cord, on the one hand, and, on the other, thickening of the membranes of the brain and spinal cord, together with a wasting of their substance, it is in other cases as certainly evident that no such structural change is present. On no other supposition can we account for the rapidly and permanently beneficial effects that so frequently follow the use of electrization in cases of alcoholic paraplegia.



# **ELECTRO-SURGERY.**



## CHAPTER I.

*Electro-surgery is that branch of electro-therapeutics which includes the electrical treatment of the diseases commonly known as surgical.*

Besides the four medical applications of electricity,—localized faradization, localized galvanization, general faradization, and central galvanization—all of which may be used for surgical diseases, it includes *galvano-cautery* and *electrolysis*, both of which may be regarded as peculiar to this department.

*History of Electro-Surgery.*—The history of surgical electricity, though to a considerable degree interwoven with the history of electro-therapeutics in general, is yet sufficiently distinct to entitle it to special consideration.

Electro-surgery was born in one of the darkest eras of electro-therapeutics, the decade just preceding the great discovery of induction by Faraday, in 1831. The distrust and neglect with which at this period especially electro-therapeutics was regarded by men of science was due partly to the reaction that inevitably followed the extravagant hopes that had been raised on the discovery and popularization of the voltaic pile at the beginning of the century; partly to the inconstancy and unreliability of the pile itself, partly to the almost absolute ignorance of the profession concerning the indications for, the effects of, or the methods of using electricity; and partly also to the fact that it was confounded with mesmerism, which, after creating absurd and wide-spread excitement, had fallen into deserved and permanent neglect.

It was in the middle of this era, in the year 1825,\* when the cause of electro-therapeutics seemed hopelessly lost, that Sarlandiere † called renewed attention to this despised agent by proposing the employment of *electro-puncture*, in order to bring the current more directly to bear on the deeper tissues. The first experiments were made with statical electricity.

The subject was afterwards studied by Magendie, who used electro-

\* Two years previously (1823) Prévost and Dumas had attempted, with some success, the dissolution of calculi of the bladder in animals; and many years before some surgical diseases had been treated electrically, but the subject was not systematically studied until 1825.

† *Mémoires sur l'électro-puncture*, Paris, 1825.

puncture with the galvanic current (galvano-puncture) in the treatment of various diseases. At first electro-puncture was used medically more than surgically. The treatment of aneurisms by this method was of a later date.

The idea of causing coagulation of the blood by galvano-puncture was originally suggested by Scudamore, and in 1831 Guérard, Pravaz, and Leroy d'Etiolles proposed the treatment of aneurism by this method, which was first practised by B. Phillips, about the year 1832,\* and afterwards studied by Liston.

In 1839 Schuster successfully employed electro-puncture for the treatment of hydrocele and other serous effusions, and in 1843 he reported his successes to the French Academy.

In 1839, and the following year also, Crussel, whose name is so prominent a figure in the history of electro-surgery, began his investigations on electrolysis.† His experiments excited little interest in the profession.

In 1843, also, Steinheil and Heider suggested the theory that the nerves of teeth might be killed by placing a platinum wire, heated by the passage of a galvanic current, in the cavity, and in 1845 Heider first successfully employed this method. He used for this purpose one very large element of Grove. The operation took but a few seconds.

In 1846, Crussel, whose name, as we have seen, is also to be remembered as the founder of electrolytic treatment, successfully removed by the heated platinum wire a "large fungus hæmatodes, situated in the frontal and ocular region."

In the same year Petréquin, of Lyons, obtained successful results in the treatment of aneurisms by galvano-puncture. The year 1846 may therefore be regarded as one of special significance in the history of electro-surgery. About this time also, the same treatment was used by Burci, of Italy.

In 1847 Bertani and Milani first treated varicose veins by galvano-puncture. In the same year Crussel published his method of treating ulcers by availing himself of the electrolytic powers of the galvanic cur-

\* Erichsen's Surgery, p. 513.

† Frommhold, *Electrotherapie mit besonderer Rücksicht auf Nerven-Krankheiten*, Pest, 1865, p. 104.

The first experiments with electrolysis were made much earlier than this; since, according to Brenner, Mongiardini and Lando had used a needle-shaped electrode, connected with the negative pole (probably of a voltaic pile, which was then just coming into notice), for the treatment of gangrene. *Dell' applicazione del Galvanismo alla medicina*, Genova, 1803.

rent. This author observed that when two metallic plates are connected with the poles of a galvanic apparatus, and applied to the body, very different effects were produced at the two poles—the positive acting like an acid, and making harder the tissue; the negative like an alkali, and causing an increase of fluid. On the strength of this observation, Crussel treated ulcers and cancers by a flow connected with the positive pole of the apparatus, while the negative was in the hand of the patient. The result of this treatment was to cause a scab to form, which fell off, leaving the sore smaller and more healthful in appearance. Repeated treatment of this kind wrought cures.

In the same and the following year, Crussel formally called the attention of the profession to “the electrolytic method of cure.” \* For the treatment of strictures another method was subsequently investigated by Willebrand, Wells, Ciniselli, and has recently been revised by Scouteten, Mallez, Tripier, and others. In 1850 Marshall suggested and successfully employed the galvano-cautery in the treatment of fistulæ.

In 1852 Baumgarten and Wertheimer, with the co-operation of Malgaigne, successfully operated on an aggravated case of varicose veins in the arm.

In 1852, also, Ciniselli,† who still cultivates with distinguished success the department of electrolysis, first established by experiment that *the alkalies appear at the negative, and the acids at the positive pole*. His method of demonstration was to lay a piece of flesh across the edges of two vessels filled with distilled water, and alternately connecting each of the vessels with a pole. The acids were found in the vessel containing the positive pole, and the alkalies in the vessel containing the negative. The piece of flesh was shrunken and burned.‡

In 1853 Ellis first used the heated platinum wire for cauterization of the cervix in inflammations and ulcerations. In this same year Hall successfully treated a case of ununited fracture by galvano-puncture.

A great and important impulse was given to galvano-cautery by Middeldorpf, who, in 1854, published his celebrated work on the subject. ||

\* Die Electrolytische Heilmethode. Neue Med.-Chir. Zeitung, 1847, No. 7. Med. Zeitung Russlands, 1847 and 1848. Quoted by Meyer, op. cit., p. 474.

† Dell' azione chimica, dell' electricita, Cremona, 1852.

‡ Brenner, Untersuchungen und Beobachtungen auf dem Gebiete der Elektrotherapie, Bd. ii., p. 265.

|| The Galvano-Causic, Breslau, 1854.

In 1855 Demarquay removed a swelling of the submaxillary gland by galvano-puncture. In the same year, Vergnès and Poey published their experiments on the removal of poisonous metals from the body by the electro-chemical bath.

In 1856 Boulu caused resolution of tumors in a number of cases by magneto-electricity, applied by means of metallic disks. Two cases of swelling of the parotid gland were in this way entirely cured. In the same year Meding extracted mercury from a patient who had long suffered from mercurial poisoning, by means of the electro-chemical bath.

In 1858 and 1859 Zsigmondi published the result of his successful experience with galvano-cautery after the system of Middeldorff. In 1859, also, Delstanche, Lehmann, Burdel, and Thevisen reported successes in the treatment of hydrocele by *farado-puncture*.

In 1861 Braun and Von Gruenewald introduced the galvano-cautery into gynæcology, where it has since been employed for the removal of polypi, excision of the cervix, and so forth.

Both in the extent and the variety of his operations in this department Middeldorff far surpassed all his predecessors. He devised a powerful, though somewhat bulky apparatus, as well as various burners and loops for operating on different parts and organs of the body.

In 1867 Althaus\* revived the attention of surgeons to the surgical powers of electricity, by reports of successful experiments in the treatment of nævi and tumors of various kinds by electrolyzation.

During the past five years extensive researches have been made in nearly all the prominent departments of Electro-Surgery by the authors of the present treatise.† The results of the researches are recorded in this section. Experiments made in those departments of Electro-Physiology bearing on Electro-Surgery have already been recorded in the section on Electro-Physiology. During the same period the various departments of Electro-Surgery have been studied by Althaus, Von Bruns, Byrne, Groh, Neftel, Duncan, Newman, Voltolini, Caldwell, Prince, ourselves † and others.

*Surgical compared with Medical Electricity.*—In comparing this history of *surgical* with that of *medical* electricity, we observe a number of interesting points both of similarity and of contrast. Surgical is much younger than medical electricity, dating, as we have seen, from 1825. In neither department has the progress been uniform or consistent.

\* Tumors and other Surgical Diseases. 1867.

† Clinical Researches in Electro-Surgery. By A. D. Rockwell, A. M., M. D., and George M. Beard, A. M., M. D. William Wood & Co. 1873.



Eras of extravagant expectation have been followed by eras of indifference, although with surgical electricity the contrast has been much less marked than with medical. The interest that was aroused by the introduction of electro-puncture in 1825, of electrolysis and galvano-cautery in 1846-47, was followed by a reaction of neglect that allowed the whole subject to sink into nearly absolute forgetfulness. The progress of surgical even more than of medical electricity has been impeded by want of convenient and reliable apparatus, and by this difficulty is explained the fact that so few workers have entered this most promising field. While the number of experimenters in medical electricity, both in the profession and out of it, and in various countries, is very large, including very many of the ablest writers of modern medical literature, the practice of distinctly surgical electricity has been confined to a few, and the authors by whom it has been really advanced could be counted on one's fingers.

Surgical, unlike medical electricity, has been studied and pursued mainly by men of science, and the progress that has been made in it has been much more frequently the direct result of scientific observation and experiment. Those physicians who have made eras in medical electricity have done so by improving, developing, systematizing, and introducing to the profession methods of treatment which either by charlatans or others had been substantially known and practised before them. Sarlandiere, Stenheil, Heider, and Crussel, on the contrary, first suggested and employed as well as introduced to the profession electro-puncture, galvano-cautery, and electrolysis.

Another important distinction is this, that nearly all the surgical diseases for which electricity is employed have been treated with more or less success by other methods, while in many of the medical diseases in which electrization has been most successful it has been the chief, and in some the only dependence.

Finally, it should not be forgotten that the surgical successes achieved by electricity have been of great service to electro-therapeutics in general. A surgical operation appeals to the eye and to mechanical skill, while medicine appeals more to the higher and rarer qualities of reason and imagination. Many who fail to comprehend a complex medical fact or principle may be fascinated and carried to enthusiasm by whatever strikes the senses. Hence we find that the suggestion of electro-puncture in 1825 revived an interest in electricity that its purely medical applications failed to sustain, and from that time to the present the fortunate operations of galvano-cautery and electrolysis have aroused the attention of many who had no faith in



and no comprehension of the remarkable powers of electricity over nutrition.

*Temperament of the Patient less important in Surgical than in Medical Electricity.*—In medical electricity, as we have seen, the results of treatment largely depend on the temperament. Some can bear almost any amount of electrical treatment, others can bear but a little, and others still can bear none at all (see p. 254). We have seen in the chapter on Hysteria and allied Affections that symptoms for which electricity is peculiarly adapted, and over which its greatest victories are obtained, sometimes refuse to yield and are indeed aggravated when any form of electricity is used by any mode of application, for the reason that the *temperament* of the patient contra-indicates electricity. Temperaments that will not bear electricity at all or but little are quite frequently found, especially among the better classes. In surgical diseases that are treated by distinctively surgical applications of electricity the temperament need not usually be taken into account. Electro-surgical operations are of a thermal or chemical character, and are not dependent for their success on the idiosyncrasy of the patient. We have seen, furthermore, that the electro-susceptibility of patients may appear either in the form of *farado-susceptibility* or *galvano-susceptibility*—some who can bear and be benefited by the faradic current, cannot bear the galvanic, and *vice versa*. In electro-surgical operations the possibility of these special idiosyncrasies need not be considered. It is true that patients behave very differently after electro-surgical operations, that some suffer from irritative fever and others do not, and these differences of effect may very likely be due to differences of electro-susceptibility, but such differences are not usually of sufficiently serious importance to require consideration.

## CHAPTER II.

### ELECTROLYSIS—ITS NATURE AND GENERAL METHODS.

THE definition and derivation of electrolysis, as well as its general laws and phenomena, have already been given (see Electro-Physics, Chapter IV.). Its physiological relations have also been presented in considerable detail (see Electro-Physiology, p. 91). It remains for us here to speak only of electrolysis in its surgical relations, and to describe the rules and methods of the various operations in which it has been found of service. Electrolysis in surgery is, however, so closely dependent on electrolysis in physics and physiology, that no one can intelligently utilize and explain it in operative procedures who does not also understand its physical and physiological relations.

The term electrolysis is a general one, and signifies decomposition by electricity. As such it applies to the electrical decomposition of inorganic as well as organic substances, and of animal tissues, whether in health or in disease, living or dead. Practically, however, the term is now pretty well restricted, in electro-therapeutical language, to the electrical decomposition of morbid growths, or to parts affected by chronic inflammation, by means of some form of needle electrodes, and although more or less electrolytic action takes place in all applications of the galvanic current externally or internally, yet the term, when applied to any electrical operation, is understood to imply that electrolytic action was the leading effect sought for, and that it was obtained by needles, or at least by some form of metallic electrode more or less pointed at the extremity.

On the other hand, when electrodes with very large surface are used, with a view to chemical effect, and the transfer of fluids with absorption, the process is called *catalysis*. Catalysis depends in part, at least, on electrolysis, and the distinction between the terms, which has been observed by electro-therapeutists is practical rather than scientific.

*Theory of Electrolysis of Morbid Living Tissue.*—For electrolysis, living as compared with dead tissue has the twofold advantage that its solutions are warmer and therefore better conductors, and that it is capable of the processes of absorption.

When needles connected with the poles of a galvanic battery are inserted into a tumor, a threefold action is produced.

1. *Decomposition of its fluid Constituents.*—Hydrogen and alkalies, soda, potassa, etc., go to the negative, and oxygen and acids to the positive. The special character of these electrolytic phenomena will depend on the character of the tumor, and the rapidity of the action will be proportioned to the relative amount of its fluid constituents. As the body is mostly composed of water holding salts of potash, soda, etc., in solution, it is a good electrolyte, and in most of the conditions of disease undergoes rapid decomposition. Scirrhous and fibroids, when hard and firm, require considerable strength of current, and are electrolyzed with comparative slowness. Erectile tumors, which are almost entirely of fluid composition, can be electrolyzed very rapidly. Although electrolytic action takes place at both poles when inserted in tumors, as when inserted in inorganic substances, yet this action on the whole appears to be the more vigorous and more effective for causing absorption and disintegration at the negative pole, and in practice this pole is usually found to be the more efficacious, although successful results are obtained by the positive pole or by both combined. Epithelioma, being largely composed of water, also decompose rapidly.

Reasoning from what we know of the electrolysis of inorganic substances, it is proper to assume that in the electrolysis of a malignant tumor, for example, the many chemical substances of which it is composed undergo manifold combinations and recombinations, the precise nature of which cannot well be fully divined, and the practical effect of which in causing discussion of the tumor can only be determined by extended clinical experience.

2. *Absorption.*—Absorption may be hastened both by the chemical changes that take place, and also by the mechanically irritating effect of the needles and the transference of the anions and cations. This absorption takes place both during and after the treatment. In some cases it is not at all observed during the operation, but goes on slowly for weeks following. Stimulation of absorption is especially marked when electricity acts on hydrocele and cystic tumors.

3. *Disintegration and Atrophy.*—As a result of the decomposition and absorption, and associated with them, the tissues become dried, separated, shrivelled, and the tumor decreases in bulk and may entirely disappear. All these processes, or rather the effects of these processes, may be distinctly observed during the electrolysis of any small wen, mole, nævus, or wart, both during and after the operation. Shortly after the needle is inserted, the growth will be seen to change in color;

the skin soon begins to shrivel and contract, like an apple when it is baking. The next day the growth will be still smaller, and perhaps nearly or entirely obliterated.

*Apparatus for Electrolysis.*—Electrolytic action is chiefly obtained by the *galvanic current*, although there is little question that the faradic current (both the electro-magnetic and magneto-electric) has more or less electrolytic power, and the magneto-electric current has been used in electro-plating.

The magneto-electric rotary machine, as constructed by Saxton or Stöhrer, is capable of producing electrolysis.\* It has, however, for this purpose, in therapeutics at least, no advantage, and decided disadvantages as compared with the galvanic current.

*It has been shown that for the purposes of galvano-cautery quantity with moderate tension was required, and that this was obtained by a few large elements; for the purposes of electrolysis tension with moderate or fair quantity is required, such as is obtained by a considerable number of elements of medium size (see chapter on Ohm's Law in Electro-Physics, p. 66).*

Any of the galvanic batteries described in the chapter on apparatus, can be used for electrolysis. The zinc-carbon batteries are the best for the purposes of electrolysis, but with the cabinet battery and with most of the combinations and modifications of Daniell's cells, the electrolytic action is comparatively feeble, and only answers for trifling operations. Deficiency in electrolytic power in a battery may to a certain extent be compensated by protracted applications.

*Methods of Testing the Electrolytic Batteries.*—Batteries may be approximately tested with a view to ascertaining their comparative advantages for electrolytic operation, by the amount of deflection they cause to the needle of the galvanometer of known construction (p. 40); by the rapidity and amount of decomposition which they cause in simple compounds, such as acidulated water, iodide of potassium, or common salt, and by their capacity for heating platinum wire (p. 71).

An approximate test for the qualities that are needed in electrolytic operations is found in the decomposition of iodide of potassium. The rapidity with which this yields to the current of a battery, and the amount of iodine evolved in a given time, very fairly indicates the capacity of that battery for electrolytic purposes.†

\* See Frommhold's *Electrotherapie mit besonderer Rücksicht auf Nerven-Krankheiten*. Pest, 1865, p. 104.

† In experimenting with galvanic batteries care must be taken to avoid frequent or long-continued connection of the *metallic* portions of the electrodes, since, on account

*Needles.*—For producing electrolysis in tissues beneath the skin fine needles of gold or gilded steel are used. The advantage of the gold is that it resists oxidation better than any other metal. Gold or gilded needles can, however, be used only with the negative pole, since with the positive they would be acted on. The conductors may be composed of two, four, six, eight, or more needles. The needles may be insulated with hard rubber, or collodion, or shellac, for about one-third of their length, so that when introduced into a tumor the skin may not be acted on and inflammation excited. Insulation, however, is only necessary in those cases where, as in subcutaneous nævi, it is desirable that the skin should not be affected by the current.

The shape of the point is of considerable importance. Round needles are introduced with difficulty. The bayonet-pointed needles are preferable. The common glover's needle, as sold in the fancy stores, we have found to be easier of introduction than any other form.

Althaus has employed a *conductor*, a modification of which is represented in the following cut :

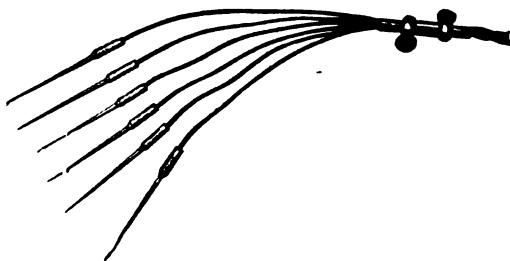

FIG. 137.  
Conductor for Electrolysis.

This consists of a conducting wire, composed of a number of small wires twisted, with a number of branches, each one of which is so arranged that it can be attached to a needle after it has been introduced into the part to be treated.

The advantages of this arrangement are that one needle or more can be used, and that the number can at pleasure be increased or diminished during the operation, and that the needles can be intro-

of the feeble resistance thus offered—metals being far better conductors than the human body—powerful action takes place in the cells (as is shown by the active evolution of gases, attended with a boiling or hissing sound), which, if allowed to continue, *eats holes in and rapidly consumes the zinc.*

duced in any direction. In the conductor which we have constructed, and which is represented in the cut (Fig. 137), the needles are united to the conducting wires by being inserted in miniature cups or cavities at the end of the wires.

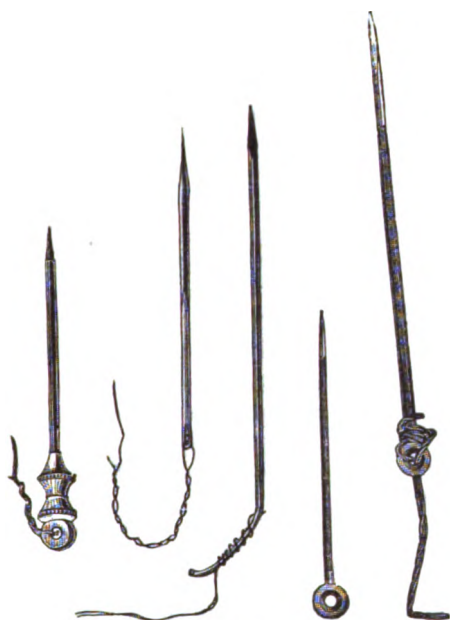

FIG. 138.

Bayonet-pointed Needles for Electrolysis,  
insulated and non-insulated (Kidder).



FIG. 139.

Rockwell's Long Needle  
for Electrolysis of Uterus  
through the Vagina or the  
Walls of the Abdomen.

*Flexible Copper Wire for Connecting the Needles in Electrolytic Operations.*—These needles are attached to connecting wires by fine flexible copper wire. Wire of this kind, it may be remarked, is a most convenient and almost necessary adjunct to an electrolytic case, and to the operating-room of the electro-therapeutist. It is useful for many

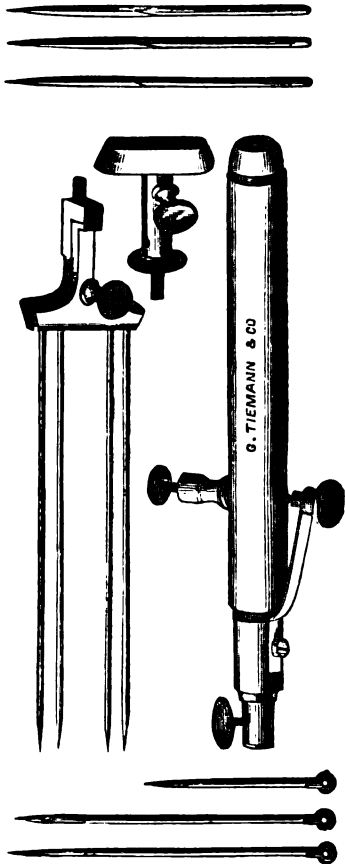

FIG. 140.  
Needles for Electrolysis, with Rockwell's Needle-Holders.

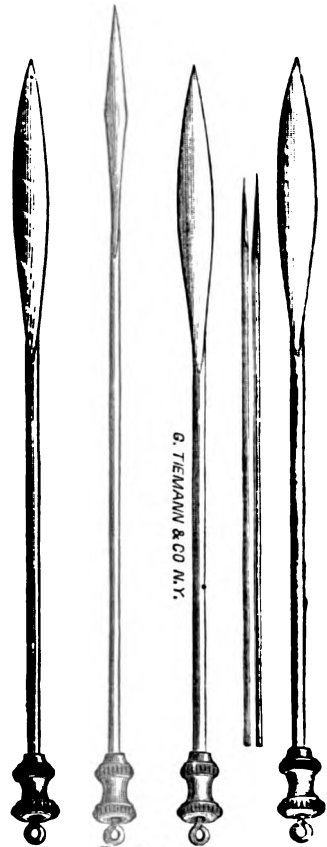

FIG. 141.  
Beard's Long Cutting Needles for Electrolysis of the Base.  
(Tiemann and Galvano-Faradic Mfg. Co.)

purposes of connection, and when thumb-screws are out of order or broken off it very well supplies their place.

Dr. Murray, of this city, has employed needles insulated at both ends, leaving an uninsulated portion in the middle. He uses these needles in the treatment of hydrocele and cystic tumors. They are



introduced so that the insulated portion is on the skin, and the uninsulated portion within the tumor.

*Method of Introducing the Needles.*—The skin in some parts of the body is quite tough, and needles go in with much greater difficulty than one might suppose. The method of introducing a hypodermic syringe is the best method of introducing needles for electrolysis. The skin may be pinched up and kept tense with the left hand, while the right pushes in the needles the required depth. If it is impossible or merely difficult to push the needles in as far as is needed, it is better to let on the current, and allow a little electrolytic action to take place around the needle. This will loosen it at the negative pole (though at the positive it will have the opposite effect, and bind it close and firm). The negative needle thus loosened can easily be pushed further in.

The pain attendant on the introduction of the needles is, of course, best combated by full anæsthesia or by ether spray; but there are many cases where anæsthetics are hardly required, where ether spray cannot be conveniently used, and where it is desirable to diminish in some way the pain. A mixture of ether and carbolic acid in equal parts, first suggested to us by Dr. Sterling, has a positively benumbing effect on the part to which it is applied. The mixture can be localized to a very small spot, and the benumbing effect begins to be felt in less than five minutes, and lasts for fifteen or twenty minutes, varying with the amount used. It turns the skin a little white. The disadvantage in its use is that it sometimes makes a slight sore afterward.

The benumbing influence of the faradic current may be utilized for this purpose (see Electro-Anæsthesia).

*Electrolyzing the Base.*—During the past three years we have been treating malignant tumors of various kinds by a method of electrolysis which Dr. Beard has termed *working up the base*, or *electrolysis of the base*.

The ordinary method of electrolysis does not suffice for malignant tumors. It will relieve the pain, but relief of pain can be obtained by simple external galvanization without any needles. It will cause a certain reduction in size, but this reduction is almost always limited, rarely exceeding ten or twenty-five per cent. In some cases, not the slightest perceptible reduction is caused, even by the most persevering use of electrolysis. When powerful currents are used, there must, of course, result more or less destruction of tissue near the point where the needles are inserted, and by successive operations the entire growth may be broken down, or may slough away after the operations are dis-

continued, and it is possible to extend the operations far into the base and surrounding tissues. Some of our first cases were treated in this way ; but it is to the last degree awkward, tedious, and involves a great waste of time and force.

*Method of Operating by Electrolysis of the Base.*—The patient must first be fully etherized. The method of operating on a *small* tumor is to first insert the needle connected with the positive pole underneath the tumor and near the border. A similar needle connected with the negative pole is inserted also underneath the tumor, and, if possible, at some distance below the base of the growth, so that the point emerges on the opposite side. The current is now gradually let on, and the strength increased until the electrolysis becomes active, as will be indicated by the yellowish foam that appears at the negative pole, gradually loosening the needle. As the action increases, the negative pole may be slowly worked from side to side, with a slight cutting motion, so as to undermine the tumor. The positive meanwhile remains *in situ* ; it becomes firmly adherent through oxidation, and need not be removed until the close of the operation.

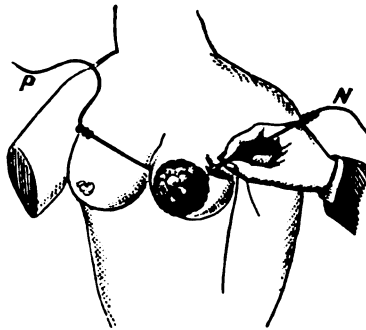

FIG. 142.

Electrolysis of the base in a case of scirrhus of the breast Large and long negative needle manipulated by the operator in the healthy tissue, some distance from the border of the tumor. Connection made by ordinary positive needle inserted near the base of the tumor.

After the tumor falls off, through the undermining of its base, the base itself can be worked up in all directions with the needles, or with the harrow electrode that we have devised for this purpose. After the removal of the growth, it is well to change the position of the poles in working up the base, so that all parts of the surface may get the benefit of the action peculiar to both poles.

If the tumor is a large one, as an extensive epithelioma, or scirrhus, it is better to have it first removed by the knife. The base can then be worked up in the manner just described.

The cavity after the operation has a charred appearance and alarms the patient and his friends unless they are forewarned.

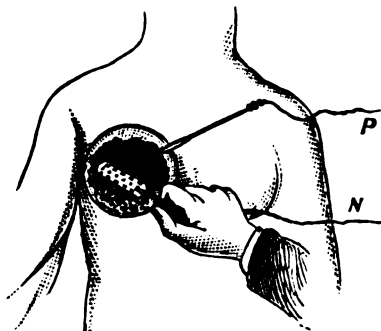

FIG. 143.

Electrolysis of the base of a scirrhus of the breast after removal of the tumor by the knife. Harrow electrode connected with the negative pole and long cutting needle with the positive pole.

The time required in an operation of this kind ranges between ten minutes to a half or three-quarters of an hour. Some swelling and œdema in the surrounding tissues follow the operation, but little or no pain, although the charred appearance of the cavity that has been thoroughly electrolyzed is sometimes quite formidable.

*Instruments Required.*—For this method of working up the base Dr. Beard has devised needles, or electrodes, that are quite different from those employed in the ordinary method of electrolysis. The needles are long, spear-shaped, double-edged, and tolerably sharp, so that a slight cutting action may be combined with the purely electrolytic action. These needles are not insulated, except in that portion that is grasped by the hand in operating. In nearly all of these operations we have used the zinc-carbon batteries of sixteen or thirty-two cells, and usually those of the Galvano-Faradic Manufacturing Company; and when a good deal of work is to be done in a short time, as in important electrolytic operations, no batteries are better than these. The various modifications of Daniell cells, which are so excellent in central galvanization, are not well adapted for powerful electrolysis.

*Theory of the Method.*—The most recent pathological investigations seem to point pretty clearly to the view that cancer, whatever the dia-

thesis may be, is a local disease, and affects the adjacent parts and the general system by actual transfer of the cancer-cells.\*

If we accept these views we must also accept the view that *cancer, whatever constitutional treatment we adopt, should be treated locally, and by some method of local treatment that acts not only on the body of the tumor, but also and especially on the surrounding tissue, and that the earlier such treatment is used the better the prognosis.*

When we remove the tumor and close up the wound, we leave the areola mostly untouched, and shut up the cancer cells in a soil best of all adapted to nourish them. Hence we need not wonder that the disease recurs either immediately in or near the place of removal, or that the cells wander to some distant part where another tumor appears after months or years.

The morbid or semi-morbid tissues that surround malignant tumors have been treated in various ways by caustics, in substance, by caustic needles, and by the actual and galvano-cautery. So far as we can learn from the experience of surgeons who have faithfully tried any one or all of these methods, the results are more satisfactory than the results of ordinary treatment by the knife or ligature.

The theoretical arguments that electrolysis of the base would produce more radical results than the use of caustics are based necessarily on our ideas of the nature of the electric force and of the process of electrolysis. When electrodes connected with the two poles of a galvanic battery are inserted into the animal tissue, the vibrations of the electric force not only pass between the electrodes, but extend to a considerable distance in all directions from them, and much further than the direct effect of caustics would reach.

*Advantages of the Method.*—1. Less liability to recurrence of malignant tumors.

We have kept close watch of a majority of the cases that have been treated in this way during the past three years. In the list of cases are found several epithelioma of the lips and face, and one case of malignant cystic of the neck. But one of the cases of epithelioma of the lips and face has yet recurred; although the time that has elapsed since the treatment varies all the way between three years and four months. The case of malignant cystic has not yet recurred. It is yet too early

\* See "A Lecture on the Structure of Cancerous Tumors, and the Mode in which Adjacent Parts are invaded," by Dr. Woodward, Assistant Surgeon, U.S.A. The Toner Lectures of the Smithsonian Institute, Washington, November, 1873. See also the recent and admirable discussion on the subject by Drs. De Morgan, Hutchison, Paget, and others, in the *Lancet* for March and April, 1874.

to arrange any statistics on this subject, for, as every surgeon knows, some cases of epithelioma are permanently cured by the knife, and their prognosis under ordinary surgical treatment is better than that of scirrhus of the breast, or indeed scirrhus anywhere.

Some hopeless cases—notably a case of scirrhus of the rectum, and epithelioma of the vagina—we have treated by this method in order to palliate the symptoms and prolong life, and with the most interesting and remarkable results. Indeed, we have been as much encouraged by the palliative effects obtained in these hopeless forms of malignant disease as by the apparently radical cures of milder cases.

It follows, from the theoretical considerations above given, and experience confirms this view, that the results of this method of working up the base will depend entirely on the *thoroughness with which the operation is performed*. If the base be but half electrolyzed, if patches of morbid tissue be allowed to remain, then there will be a recurrence, in all probability, just as after other modes of operating.

2. Less hemorrhage than other methods of operating. The reason for this has already been explained—electrolysis coagulates the blood, constricts the tissues, and slightly cauterizes them. Ordinary parenchymatous hemorrhage is thus controlled in the most satisfactory manner, so that if a strong current is used, neither sponges nor styptics are required.

3. Less liability to shock. We form this judgment from protracted operations made on patients in various stages of debility, and in the extremes of life, infancy and old age. We have not yet seen any effect at all suggestive of shock, after very long sittings under strong currents, even where sensitive localities were operated on. The electric current would indeed appear to be one of the very best *antidotes* to shock, and for a long time it has been known and used as a means of resuscitation.

4. It is followed by a more satisfactory healing than other operations. This fact has been observed markedly in several severe and hopeless cases, and has attracted the attention of all the surgeons who have seen the cases.

5. There is reason for the belief that the future will show that septi-cæmia and pyæmia are less likely to follow electrolysis than other surgical operations. It is more than probable that electrolyzation, like cauterization, constricts the absorbents so that they cannot absorb pus.

6. To all these facts must be added the consideration that many patients dread the knife—without reason it may be, and without coun-

mon-sense ; but patients are not expected to exercise reason or common-sense—and such persons are willing to submit to electricity, however employed.

The advantages of working up the base by electrolysis, as compared with working up the base by caustic, the actual cautery, or the galvanocautery, are worthy of study.

*Disadvantages of the Method.*—1. It requires apparatus more or less bulky, and they require more or less experience in their management.

2. Electrolytic operations frequently require more time than operations with the knife or ligature, and in some cases the operation must be repeated.

If electrolysis produced shock, this element of time might, perhaps, be a serious one ; but, inasmuch as it appears to act as an antidote to shock, and as the stimulus of the current allows us to prolong anæsthesia with safety, and, as in many of the cases where electrolysis is used, treatment by knife or ligature is contraîndicated, this objection need not deter us from resorting to it.

3. The irritative fever that follows powerful and prolonged electrolytic operations is sometimes severe. The parts around the tumor operated on become more or less swollen, but are not usually painful, and this swelling also soon subsides.

It is proper to state that the ordinary method of electrolysis, if thoroughly used and repeated a sufficient number of times, may run into this method of working up the base, and in epithelioma, at least, may accomplish good results. The body of the tumor may be gradually broken and destroyed ; and then, in successive operations, the needles may be made to work up the base and surrounding tissue. Groh,\* of Vienna, has used this method with success in quite a number of cases of epithelioma, as well as of sarcomatous growths. We have used the same method in epithelioma, and with success. The method has, however, the sufficiently serious objection that it first wastes the time and strength of the patient on unnecessary treatment of the tumor, and is only successful in proportion as it falls back on the method of working up the base and surrounding tissue.

\* *Die Electrolysis in der Chirurgie*, Vienna, 1871. Groh has also treated sarcomatous growths by very prolonged electrolysis, with mild currents. This method seems to have greater inconveniences, without any compensating advantages.

## CHAPTER III.

### GALVANO-CAUTERY.

*Galvano-Cautery.*—*Galvano-cautery is cauterization by a resisting wire heated by the galvanic current.* It is very often confounded with electrolysis, but as we have seen electrolysis is the decomposition of a compound substance by means of electricity. A slight cauterizing action may indeed accompany electrolytic operations, but it is incidental merely, and is not a part of the electrolysis, nor the end desired.

It is a law of electricity that when it passes through a resisting wire it raises its temperature in proportion to the resistance of the wire and the quantity of the electricity (see *Electo-Physics*, p. 80). *The wire thus heated is capable of producing cauterizing effects.* Platinum offers a greater resistance to the passage of the electric current than any other metal except mercury and lead, and is therefore used in galvano-cautery. It will be seen at once that the electricity is not applied to the body, as in the various forms of electrization, *but only the wire heated by the passage of the current.*

*Advantage of Galvano-Cautery over the Actual Cautery.*—The one great advantage of the galvano-cautery over the actual cautery is, of course, the fact that the heat in the wire connected with the battery can be controlled at will. It can be let off and on, increased or diminished at pleasure and instantaneously. With the actual cautery such control is manifestly impossible.

Heat is heat, however obtained; and the heat of a platinum wire through which a current is passing has probably no advantage as such over the heat of a poker that has been thrust into the coals. The advantage lies simply in the fact that in the one case the heat is under the complete control of the operator during a long operation if necessary; in the other case it is not under such control.

*Apparatus for Galvano-Cautery.*—Galvano-cautery operations require batteries composed of a few large cells. Rarely are more than eight cells used, and the best batteries can be turned into one or two

cells. The batteries employed in electrolysis or in ordinary galvanization are not available for galvano-cautery—*vice versa*, galvano-cautery batteries are of but little use in electrolytic operations or in ordinary galvanization. The explanation is to be found in the chapter on Ohm's Law (see Electro-Physics, pp. 77-95).

There has been great practical difficulty in obtaining galvano-cautery batteries that would be at once sufficiently powerful and conveniently portable. The original battery of Middeldorff was extremely heavy and in every way inconvenient, though, like all combinations of Grove's cells, it was very powerful.

During the past decade, and notably during the past five years, the progress in the direction of portability and convenience of galvano-

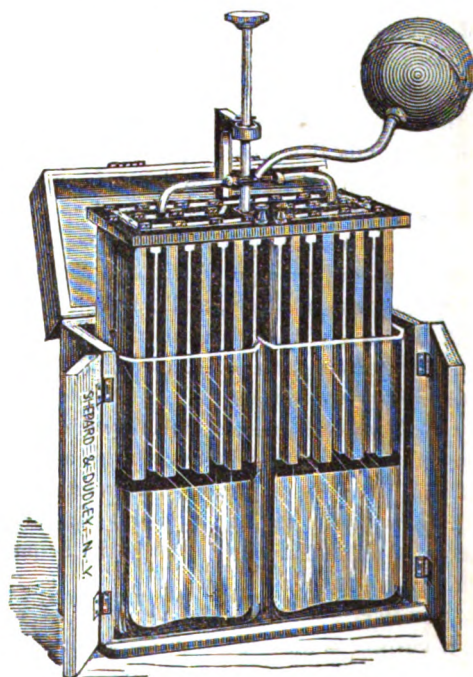

FIG. 144.

Byrne's Multiple Element Battery (Shepard & Dudley).

cautery batteries has been rapid and decided. In this department no one has labored harder or more successfully than Dr. John Byrne, of Brooklyn, N. Y. After long and tedious experimenting, he has com-



pleted a galvano-cautery battery that is as portable and easy to manage as any galvanic battery for electrolysis or ordinary galvanization.

Batteries that are non-portable, or at least not easily so, are also made by all the companies that manufacture electrical instruments. Some of them that we shall describe are most excellent. Those who make a large use of galvano-cautery will probably require two kinds of batteries—portable and stationary—just as they require portable and stationary faradic and galvanic apparatus.

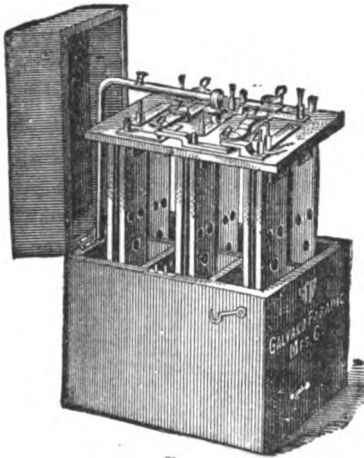

FIG. 145.

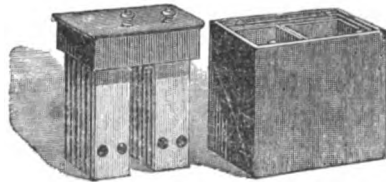

FIG. 146.

Fig. 145 represents the Piffard galvano-cautery battery, and is not only reasonably compact, but exceedingly efficient. The box contains six cells of vulcanite and a platform of hard rubber, to which are fastened the zinc and platinum plates. On the top of the platform are seven conducting posts, six connecting screws, and a handle (used in connection with the long arm) for holding the elements when not in use and by which they are lowered into, or taken from the cells. For the purpose of agitating the fluid and increasing the cautery power, there are pivots on each side of the platform, by means of which the elements are readily moved with a rocking motion. The box enclosing the cells is 9 inches long,  $6\frac{1}{2}$  inches wide, and 10 inches high.

One of the most successful attempts to combine a suitable degree of strength with compactness and lightness has, perhaps, been made by Kidder in the battery represented by Fig. 146. It is composed of but two hard rubber cells, with elements of zinc and carbon—each cell measuring  $3\frac{1}{2}$  inches in length,  $2\frac{1}{2}$  inches in width, and will retain a number 19 platinum wire at a white heat for more than a quarter of an

hour. The elements are made to move on small wheels horizontally, in their relation to the fluid in the cells. This is a great improvement on the old method of blowing with an air-bulb for the purpose of producing agitation of the fluid, and consequent increase of current strength, and seems to us to more thoroughly displace the battery fluid than any other method. For very prolonged operations this little battery is hardly sufficient, and should be replaced by the larger form, consisting of four cells.

*Byrne's Multiple Element Galvano-Cautery Battery.*—Byrne's combination of zinc-carbon elements is the most compact and portable battery for galvano-cautery purposes yet constructed, and for its size has greater heating power than any other. This battery, in its latest modification, consists of zinc-carbon cells, in a case six inches long, nine inches high, and five inches wide. The plates of each cell are split up into a number of smaller plates, all of which are contained in one jar of fluid, and are connected at the top. By this arrangement more surface both of the zinc and of the carbon is exposed to the fluid than when the plates are not so subdivided. Besides this arrangement gives

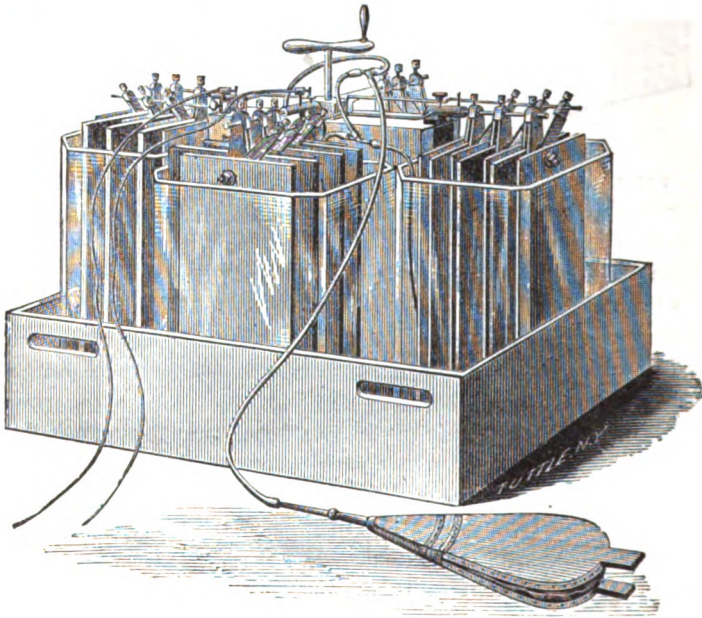

FIG. 147.

Zinc-Carbon Galvano-Cautery Battery (Galvano-Faradic Mfg. Co.).

many corners and angles on which the exciting fluid acts with greater vigor than on smooth surfaces.

The plates are very near to each other, from  $\frac{1}{16}$  to  $\frac{1}{8}$  of an inch, so that the internal resistance of the battery is comparatively small.

The arrangement is such that one or two cells can be used as may be required. The heating power of this small, light battery, is quite remarkable, and is indeed sufficient when well nurtured for a very large number of electro-surgical operations.

Dr. Byrne\* says that he has found by experiment that greater heat may be obtained from 120 inches of surface in the multiple element form (three inches by five) than from 378 inches of surface with ele-

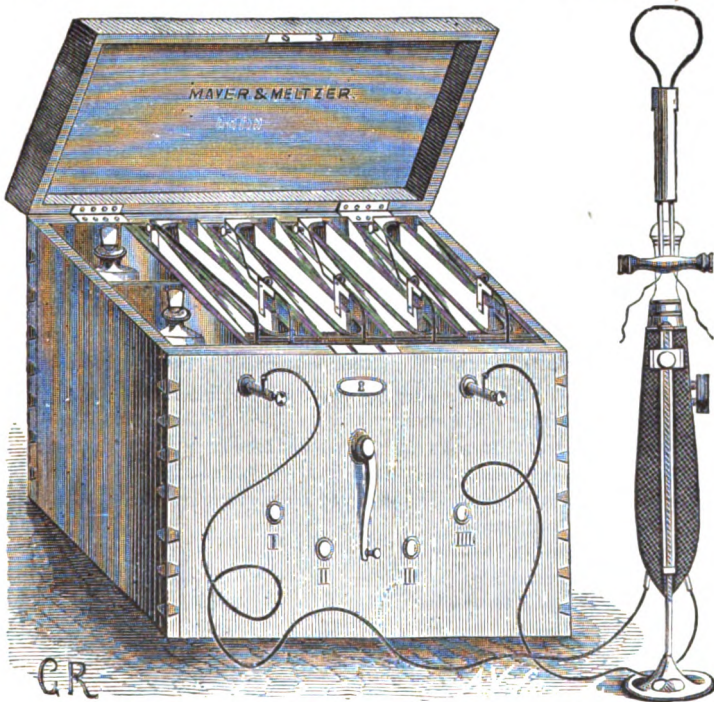

FIG. 148.

Galvano-Cautery Battery with handle and wire-loop (Mayer & Meltzer, London).

ments four times the size. While the battery made of large elements would bring five inches of platinum wire to a red heat, the multiple element battery would raise the same wire to a burning white heat.

\* *Electro-Cautery in Uterine Surgery*, p. 67.



FIG. 149.

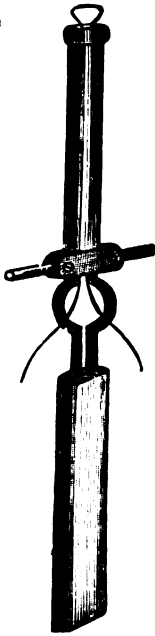

FIG. 150.

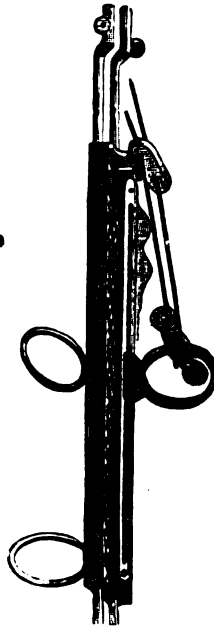
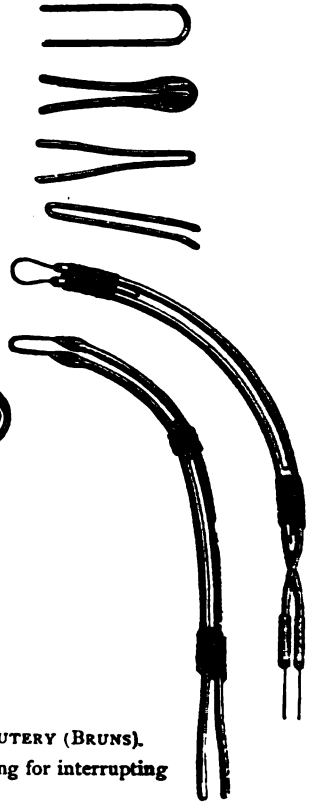

FIG. 151.



BURNERS AND CUTTING-LOOPS FOR GALVANO-CAUTERY (BRUNS).

FIG. 149.—Handle for Burner, with knob and spring for interrupting or connecting the current.

FIG. 150.—Handle and Cutting-loop.

FIGS. 152-157.

FIG. 151.—Handle for Cutting-loop where only one hand is at liberty; the other hand may be employed in holding some other instrument, as the laryngeal or aural mirror.

FIG. 152.—Burners of various shapes.

FIG. 153.—Burner for larynx.

FIG. 154.—Cutting-loop for larynx.

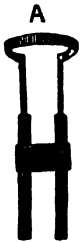

FIG. 158.

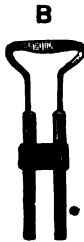

FIG. 159.

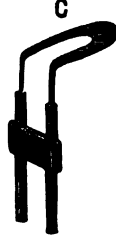

FIG. 160.



SHEPARD & DUDLEY, N.Y.

FIG. 161.



FIG. 162.



FIG. 163.



FIG. 164.

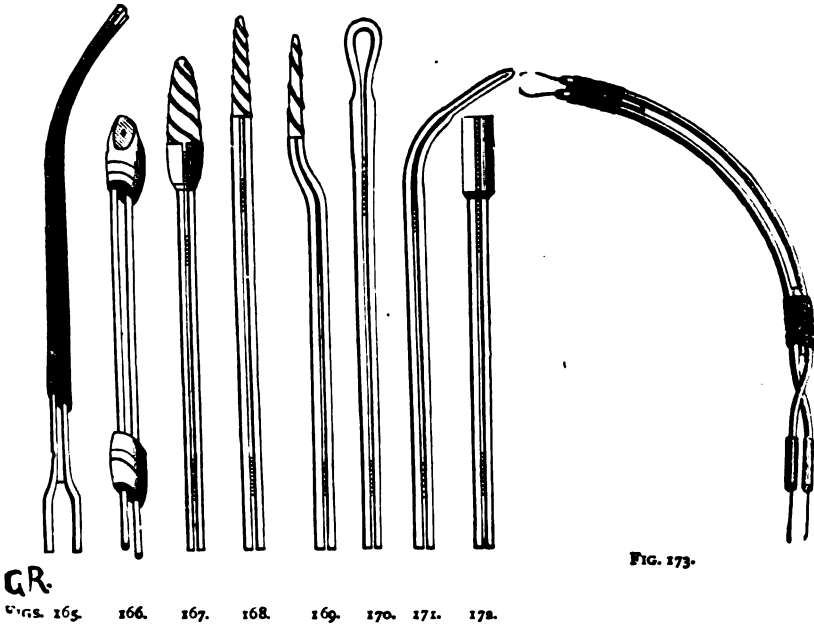

*Care of Galvano-Cautery Batteries.*—In order to attain the maximum of power from galvano-cautery batteries, and to keep them in good working order, much more care is necessary than in the case of ordinary batteries for galvanization.

The reasons for this are twofold :

1. The chemical action is very vigorous because the solutions are strong and the circuit is metallic throughout. In ordinary external galvanization or in electrolysis the resistance of the body interposed in the circuit is so great that only a small quantity of electricity can be evolved (see chapter on Ohm's Law); hence the zinc is not so rapidly consumed.

2. The galvano-cautery batteries—especially the portable varieties—have comparatively little reserve power. If the solution becomes old or the plates become corroded badly, the heat generated may be too feeble for important operations.

It is therefore necessary to frequently renew the solution entirely, and not in part, as is so often done with ordinary galvanic batteries. With the portable zinc-carbon batteries it is a great advantage to thoroughly soak the carbons in tepid water after each operation.

A practical point of much importance is that when the zinc plates

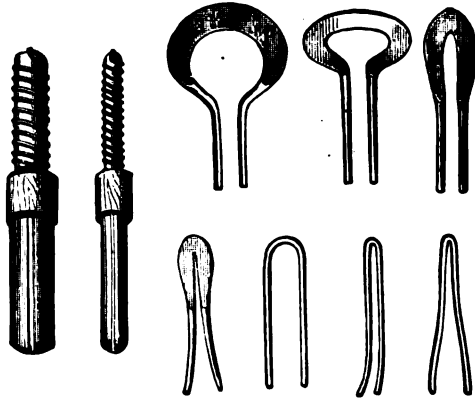

FIG. 174. FIG. 175. FIG. 176. FIG. 177. FIG. 178. FIG. 179.  
 Various forms of handles, wire-loops, cauterizers, and so forth, for galvano-cautery operations (Shepard & Dudley, Galvano-Faradic Mfg. Co., and Kidder).



FIG. 180.

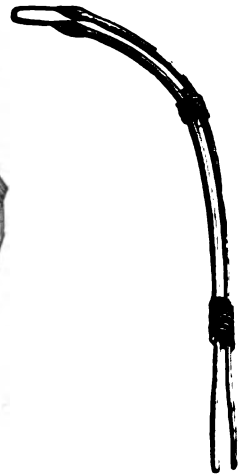

FIG. 181.

Galvano-cautery operating case (Galvano-Faradic Mfg. Co.).

become much worn, and the distance between the carbon plates is correspondingly increased, the internal resistance of the batteries is greater and the power is diminished.

*Accompanying Instruments.*—In the operation of galvano-cautery a large number of burners, loops, and handles is used. These are of every variety and can be adapted by the operator to the needs of any special case.

*Uses of the Galvano-Cautery.*—The special purposes for which galvano-cautery has been recommended and employed are the following:—

1. Removal of tumors of various kinds, in parts that are not readily accessible to the ordinary methods of extirpation—pediculated tumors of the larynx, polypi of the larynx, naso-pharyngeal space, external auditory canal, vagina, rectum, and uterus. Malignant tumors in any accessible position may be removed by galvano-cautery in order to avoid hemorrhage.
2. Amputation of diseased organs or parts of organs, like the neck of the uterus, the tongue, etc., as a palliative.
3. Cauterization of ulcers.
4. Cauterization of chronic inflammations of mucous membrane, in the urethra, nasal duct, conjunctiva, etc.
5. Cauterization of cancerous tumors to stop the hemorrhage.
6. Cauterization of the base and tissue surrounding malignant tumors that have been previously removed by the knife or ligature.
7. Cauterization of erectile tumors so as to cause coagulation, absorption, and in some cases sloughing.
8. Treatment of fistulæ, by cauterizing the fistula alone, or by cauterizing surrounding parts, or by cauterizing both the opening and the parts surrounding, or by opening the fistula.
9. Treatment of neuralgia by cauterizing and killing the nerve.
10. Treatment of prolapsus uteri by cauterizing with the burners the vaginal walls, and thus causing inflammation, suppuration, and cicatricial contraction.

*Advantages of the Galvano-Cautery.*—The advantages of the galvano-cautery over the actual and potential cautery and the ordinary operations by cutting instruments, are these:—

1. It can be used on parts that are not easily accessible to ordinary instruments.
2. It saves all or nearly all hemorrhage.
3. It combines the after-cauterizing effect with the other results of the operation, as is sometimes desirable.
4. It is more sure in its action, and can be more accurately localized, especially in cavities, than the ordinary methods of cauterization.
5. It is but little painful after the operation, and is rarely or never dangerous.
6. It is followed, like electrolysis, by a more satisfactory healing than by the knife or ligature, and as after electrolysis there is less liability to pyæmia.



The one disadvantage of the galvano-cautery is the difficulty of managing the necessary apparatus.

This difficulty is now diminishing; the advances that have recently been made in this department will bring the galvano-cautery within the reach of all who are willing to devote the amount of attention which a new department must at first demand.

There is reason to believe that in the future, with accessible and compact appliances, the use of the galvano-cautery will be greatly extended. *No one can expect to succeed with the galvano-cautery who is not to some degree a master of electro-physics.*

*Rules for the Use of the Galvano-Cautery.*—1. For all large and important operations fresh fluid should be used in sufficient quantity, and the battery should be in all respects clean and in good order.

In the use of the galvanic current for ordinary galvanization, fluid needs entire renewal but rarely, and if an evaporation or waste reduce the strength, simply pouring in new fluid into the old, or pouring in water alone will answer to bring up the battery power to the necessary standard.

2. Before beginning the operation, the apparatus should be in thorough preparation. Our battery should be tested, and the handles and wires or knives should be carefully overhauled, so that there may be no chances of bad connection or bad working of the screws, wheels, or other appliances.

3. In all operations of importance it is almost indispensable to have an assistant, whose exclusive duty it shall be to immerse and take out the elements as may be required during the various steps of the operation, or to use the bellows or air-bulb to increase the strength of the current. The operator will have all he can do to control the instruments in his hands.

4. The strength of the current employed in the operation should be carefully adapted to the size and length of the wire-loop or knife that is used in the operation. If too great a quantity of electricity is used for the size and length of the wire loop, the wire may break before or during the operation—very likely very near the close of the operation, to the annoyance of the operator. If too little quantity of electricity is used, the loop or knife will not be sufficiently heated, and will not burn through the tissues, or if the tissues are divided, hemorrhage may occur.

As the loop grows smaller near the end of an operation, the quantity of electricity should be diminished by raising the elements somewhat in the solution, so that less surface may be exposed (Byrne).



Accurate judgment in this regard can only come from careful and repeated preliminary experimentation, and from entire familiarity with the battery employed.

5. In the case of malignant growths of all kinds, the heated wire, loop or knife should go sufficiently far beneath or around the growth as to include healthy tissue. In amputation of the cervix, for example, the wire should be placed above the ulcerated or indurated part so as to remove the entire cervix, and very much more if the disease extends far into the body of the uterus.

In some cases this would be impracticable, and then it is necessary to abandon all hopes of radical or permanent relief, and content ourselves with palliation merely.

6. In cases where the wire-loop is used, the traction on it by the wheel or other contrivance should be very gradual, and by intervals, so that the surfaces of the parts exposed may be thoroughly cauterized. The temptation is to make the operation brilliant and brief, by rapidly contracting the loop. Those operators who yield to this temptation may be annoyed by immediate or secondary hemorrhage.

7. When the shape and position of a part to be excised are such that a loop cannot be adjusted, a groove should first be burned around the part by the galvano-cautery knife (Byrne).

8. The wire-loop or knife should be accurately adjusted, and be perfectly in position before the connection is made and the current let on.

9. The loop should not be contracted until it has passed into the submucous tissues, and when passing through superficial or cellular tissue, the wire should not be brought to a white heat (Byrne).

10. In protracted operations, where delay is necessary between the different stages, the elements should be raised out of the solution when the current is not needed, so as to rest the battery and economize its force.

*Adaptation of Galvano-Cautery to various Departments.*—In the adaptation of galvano-cautery to any of the special departments, one needs to be guided by the general principles already laid down. The efficient contrivances and modifications of apparatus, and of modes of operating, will depend on the skill and experience of the surgeon.\*

Dr. Byrne presents the following *résumé* of his operations with the galvano-cautery, up to December 1, 1872 :

\* On the special department of the adaptation of the galvano-cautery to gynecology, as well as for valuable suggestions in regard to galvano-cautery in general, we may refer to Dr. Byrne's work on the Electro-Cautery in Uterine Surgery.

- “19 cases of epithelioma, including cauliflower cancer.
- 11 “ encephaloid, or medullary cancer.
- 13 “ catarrhal, inflammatory, and ulcerative affections of the cervical canal of uterus.
- 5 “ amputation of cervix (non-malignant).
- 4 “ fibrous and fibro-cellular polypi.
- 4 “ sessile fibroid tumors.
- 2 “ deep ulceration of os and cervix.
- 1 “ intra-uterine vegetation (non-malignant).
- 2 “ vascular tumors of urethra.
- 4 “ granular urethritis.
- 3 “ hemorrhoids.
- 1 “ perineo-vaginal fistula.
- 1 “ lipoma of scalp.
- 1 “ lipoma of cheek.
- 1 “ lipoma of ear.

---

72

Of the thirty cases of malignant disease,

- 17 were of the uterus alone.
- 7 “ “ uterus and vagina.
- 3 “ “ perinæum and vagina.
- 1 was of the left labium.
- 1 “ “ clitoris.
- 1 “ “ breast.

Among the nineteen cases of epithelioma,

- 7 were indurated or ulcerated only, and
- 12 were of the vegetating or cauliflower character. Of the latter,
- 7 “ “ cervix uteri alone.
- 3 “ “ perinæum and vagina.
- 1 was restricted to the left labium.
- 1 of the clitoris.”

Dr. Thomas Bryant, of London, has recently published the results of a large variety of experiments with this form of “bloodless surgery.”

The cases of amputation of the cervix uteri with the galvano-cautery that have been attempted by the surgeons of the Woman's Hospital, with the assistance of Dr. Rockwell, have proved entirely satisfactory. In these cases, if the platinum wire be of sufficient size, and the cutting be done slowly, not a drop of blood need be lost.

The galvano-cautery has been used by ophthalmologists for the cau-

terization of granular lids, and inflammations and abscesses of the lachrymal ducts. By aurists it has been used for the removal of polypi and other tumors from the external auditory canal. By laryngologists it has been used for the removal of nasal and naso-pharyngeal polypi, for the cauterization of granular inflammations, for the cauterization and removal of various laryngeal growths, and for tracheotomy. One of the most successful workers in this branch is Voltolini.\*

In the rectum the galvano-cautery has been recently utilized for operation on fistulæ and for the removal of piles. By general surgeons it has been used for amputation, and for the treatment of epithelioma and other malignant growths.

The following operation by the galvano-cautery is a good illustration of its value and efficiency :

CASE CXC VII.—We were requested by Prof. James R. Wood to see with him a patient from whom he had some time before removed a cancer of the lip. The man was now suffering from a larger growth of a malignant character, situated on the right side of the neck, and adherent apparently to the hyoid bone. The tumor was so exceedingly vascular that it was thought not expedient, by Dr. Wood, to use the knife, and he therefore determined to try the galvano-cautery. The patient having been etherized by Dr. J. W. Hunt, Dr. Wood proceeded to dissect back the skin; but the substance of the tumor was found to be so thoroughly broken down, that it was resolved to extirpate thoroughly, without regard to its covering. The circumference of the tumor was so great, that instead of attempting to encircle the whole at once, Dr. Wood pierced it at its base and centre by a grooved director, and along this we thrust the free end of our platinum wire, and as it came out at the opposite side, it was fastened in the other half of the operating handle, thus forming a loop around one-half of the tumor at its base. The circuit was now closed, the loop gradually contracted, and the amputation of the portion enclosed speedily accomplished. The other half of the enlargement was, in the same way, readily cut away. Substituting now the cautery knife for the wire, as much of the underlying tissue was removed as could be with safety attempted, owing to the position of the disease. During the operation only an insignificant amount of blood was lost, and but one small artery called for ligation. No untoward symptoms followed, and the patient made a good recovery.

\* Die Anwendung der galvano-kaustik in Innern des Kehlkopfes und Schlundkopfes. Wein, 1872. On the Application of the Galvano-Cautery to Laryngology. See also Cohen's Diseases of the Throat, 1873.

## CHAPTER IV.

### BENIGN AND MALIGNANT TUMORS.

**THE** success of the electrolytic procedure in benign and malignant tumors depends on the method used. One may fail by one process and succeed by another, just as in any other surgical operation. The tendency has been to be satisfied with the mere employment of galvanopuncture, without regard to the method, and to accept the results, whether favorable or unfavorable, as serving to settle the question of the value or uselessness of electricity in surgery.

In electrolysis everything depends on the method ; and with the same method skill, care, and thoroughness may succeed, when awkwardness, carelessness, and inattention fail utterly. The failure of electrolysis in any form of tumor—benign or malignant—is not to be counted a reproach until we know the actual method used and the character of the operator.

The errors that have been and are continually made in electrolytic operations begin and end, as we have seen, in ignorance or forgetfulness of the laws and facts of electro-physics and electro-physiology, and especially of the former. No one can be a scientific and successful electro-surgeon without also being more or less of an electro-physicist.

#### NÆVI—ERECTILE TUMORS—ANGIOMATA—MOTHER'S MARKS.

Nævi (erectile or vascular tumors) are both cutaneous and subcutaneous. The terms cutaneous and subcutaneous, however, simply indicate a difference in seat, but not in kind. The two forms are often associated, and the wide-spread dilatation of cutaneous vessels, attended with little swelling, that are commonly called "mother spots," are evidently similar in character to the subcutaneous variety to which Bell gave the name of aneurism by anastomosis. Erectile tumors may be either venous or arterial.

This variety of tumors may be treated by the ordinary method of electrolysis, with a good probability of success, provided the conditions of success are skilfully observed.

It is first of all necessary to understand that to cure all forms of erectile tumors electrolytically without leaving any scar or trace is simply impossible. In many cases, and notably in those of larger size, and which are partly cutaneous and partly subcutaneous, sooner or later destruction of tissue is requisite to bring about a cure; and destruction of tissue after electrolysis, like destruction of tissue after the use of other agents, is followed by cicatrization.

When the *nævus* is small and superficial, then a mild electrolytic operation may be followed by a shrinking of the tumor, and a rapid and permanent absorption of the *débris* without any scar; but such cases can hardly be said to constitute the majority. The scars following the electrolytic treatment of *nævi* may, however, rapidly disappear; at least the little patient may in time entirely outgrow them.

It is necessary to be understood, in the second place, that the electrolytic operations for *nævi*, as for other kinds of morbid growths, are usually sufficiently painful to require some form of local or general anæsthesia. It is almost absolutely *safe* to give ether to young children; and the operation, even though it be but very short and but little painful, can be conducted far more successfully when the child is anæsthetized than when it is not. With adults, and sometimes with children, local anæsthesia by ether spray is sufficient; but it is generally inferior to general anæsthesia. The struggles of the child to get free, its terror at the sight of the instruments, can all be saved by a carefully administered anæsthetic. The details of the operation differ with the site and character of the tumor. Success has followed the use of both poles in the tumor, or only one, while the connection is made by a sponge-electrode on some indifferent point. If the tumor be small, and but one pole is used, it is better that it should be the positive, since the clot formed at the positive pole, though small, is hard and firm. If the tumor be large, needles connected with both poles may be used. Whether one or more needles are to be used depends on the size of the tumor, but generally one needle connected with each pole is sufficient. If many needles are used, it is difficult to manage them; and some may fall out, and thus disturb the operation. It is better, as a rule, to take out the needle at different stages, and insert it in various parts, until the entire growth is acted upon. We have sometimes found it of advantage to reverse the current during the operation, so that all portions of the tumor may be acted on by both poles. Insulation of the needles is only required in the case of entirely subcutaneous tumors—where, as in the case of aneurism, it is desired to produce a coagulum (which may be slowly absorbed) without injury to the skin.

The length of the operation may range between five and twenty-five minutes, according to the strength of current used, the size of the needles, and the size of the tumor.

The great point in all electrolytic operations for *nævi* is to do just enough without doing too much. If the operation be not reasonably thorough, absorption will not take place, or the tumor may recur. If the operation be too extensive or prolonged, the destruction of tissue may be greater than is needed, and the subsequent cicatrization may amount to at least a temporary deformity. For very large and semi-cutaneous or semi-subcutaneous *nævi*, that exhibit a tendency to spread in all directions, it is necessary to place the needles at or near the base of the tumor, and in the surrounding tissue, among the enlarging and tortuous vessels, in a manner somewhat resembling the method of electrolyzing the base of malignant tumors. If such tumors are treated timidly, no good result will come, and the operation may be several times repeated without satisfaction.

The advantages of the electrolytic procedure in *nævi* are these :

1. In small and superficial tumors, the cure may be effected with little or no scar. On the face and other exposed parts of the body, this advantage is very great.
2. In large *nævi*, and those which are partially or entirely subcutaneous, the liability of recurrence would be less, and probably the extent of the cicatrization would be less than after the ordinary method of treating these growths.

*Subcutaneous erectile tumor of the right cheek; complete recovery follows electrolytic treatment.*

CASE CXCVIII.—In April, 1871, Dr. D. F. Reynolds consulted us in regard to the case of a little child aged eight months, who was afflicted by a subcutaneous erectile tumor in the right cheek. It appeared shortly after birth, and had gradually enlarged until the date mentioned, when it measured one and a half inches in width and from one-half to three-quarters of an inch in depth. Upon firm pressure the enlargement would almost entirely disappear. The patient having been placed under the influence of chloroform, we operated at Bellevue Hospital, in the presence of Dr. Frank Hamilton and his class, by introducing into the four quarters of the tumor four small gilded steel needles insulated to within one-quarter of an inch of the points. Two of the needles are connected with the positive and two with the negative pole.

During the passage of a current of very moderate tension the enlargement gradually grew harder and more prominent as the blood coagulated, and at the expiration of eight minutes, when the needles were withdrawn, the part was quite firm. The child suffered no inconvenience during or after the operation, and when seen the next morning was as well and playful as usual. The process of absorption soon became manifest, and in two months three-quarters of the clot had disappeared.

From this time there was a most marked decrease in the rapidity of absorption, since but two months more were required before the clot had entirely disappeared.

*A large arterial tumor in a weak, ill-nourished child; the result of electrolytic treatment unsatisfactory.*

CASE CXCIX.—Annie—, a child aged one year, was directed to us by Dr. H. P. Farnham. On her back, over the upper dorsal vertebræ, we found a large fluctuating arterial tumor, nearly two inches in diameter at its base.

The child was markedly anæmic, and her general condition was much below par.

It was thought best, however, to operate, and in the presence of Drs. Farnham, Pinkney, Grant, and others, the needles were used in the same manner as in the previous case. Coagulation was readily produced, but owing to some unpleasant symptoms in the respiration of the child the needles were withdrawn (as the progress of the case subsequently attested) a little prematurely.

Absorption set in very slowly indeed, and after a few weeks its effects were barely perceptible. After a couple of months it was evident that the circulation in one portion was beginning to be re-established, but the mother refused to allow anything more to be done for the little patient. It should be stated that on the night following the operation, the child was allowed to lie upon its back with the hard enlargement of coagulated blood entirely unprotected. Subsequently a soft circular ring was prepared and placed around the tumor, but the irritation already caused by the pressure was followed by slight ulceration and discharge.

This, however, healed in the course of two weeks, but it undoubtedly contributed towards the general unsatisfactory result. The slowness with which the absorbing process was carried on is to be attributed undoubtedly to impaired nutrition, and the re-establishment of the circulation mainly to the unfortunate necessity of cutting short the operation.

*Arterial erectile tumor from birth in a child fifteen months old; complete recovery under electrolyzation.*

CASE CC.—In a little child fifteen months old, upon whose face, near the angle of the lower jaw, a small erectile tumor had existed from birth, electrolysis was completely successful. The patient was placed under the influence of chloroform, and two platinum needles, insulated to within one-third of an inch of the points, and connected with the positive pole, were introduced into the two lower quarters of the tumor; while two steel needles, connected with the negative pole and insulated in a similar manner, were thrust into the two upper quarters. The current from twelve medium-sized cells of a zinc-carbon battery was allowed to pass for ten minutes, at the end of which time the coagulation was complete. Absorption of the clot rapidly became manifest, and in four months it had entirely disappeared, leaving no scar.

In subsequent operations we have not hesitated to use steel or gilded needles for the positive pole, since the oxidation which these needles undergo in all probability tends to accelerate coagulation.

*Subcutaneous erectile tumor treated by electrolysis; too strong currents used; subsequent sloughing.*

CASE CCI.—A the request of Dr. Geo. K. Smith, we operated, November 22, 1871, on a case of subcutaneous erectile tumor, just over the inner angle of the eye

in a child sixteen months of age. The tumor, which was about the size of a hazelnut, could easily be compressed. The child was thoroughly etherized with the assistance of Dr. F. H. Colton, and three insulated needles were inserted into the tumor—two connected with the positive, and one with the negative pole.

The current was from sixteen weak cells; the *séance* twenty minutes. The color of the tumor changed during the operation and became hard through the coagulation. Subsequently the tumor sloughed at certain points, and the result was not satisfactory, since a deformity was left that may be permanent.

The mistake we made was in using too strong a current and unduly prolonging the operation. In our desire to avoid repeating the operation, we went to the other extreme.

The delicate skin of the child was so affected by the action of the current that sloughing ensued in spite of the insulation of the needles. This mistake is one that can be easily avoided.

Dr. Rockwell, by a somewhat rare coincidence, treated, within a comparatively short time, four widespread *nævi* involving the nose. The first case, sent by Dr. Lafayette Ranney, submitted to two operations. The first successfully obliterated the dilated vessels of one-half the nose; but circulation becoming re-established in the other half, a second operation, performed after an interval of several months, resulted in complete recovery. The second case, sent by Dr. Stephen Smith, was apparently successful; but as it passed from under his observation, he is uninformed of the ultimate result. The remaining cases recovered promptly after a single operation, and with hardly an appreciable scar.

Drs. L. F. Sass and R. P. Lincoln, of this city, have communicated to us the details of an interesting case of successful treatment of a venous erectile tumor of the neck:—

The patient, Gen. K., aged 33, of nervous temperament, represented that in April, 1869, after a special effort in public speaking, he felt a pain in his neck, on the left side. Six weeks later a small tumor appeared in the locality of the pain, which in a few months increased much in size. It was subsequently reduced by sulphur-baths, cathartics, tincture of iodine, etc., but returned, and in February, 1870, was again reduced by the same treatment, which left him, however, exceedingly weak. July 4, during the excitement of a public reception, the tumor again appeared, with severe pain, loss of voice, and feeling of suffocation, so that death appeared imminent; and again it was dispelled by the same treatment. On account of the frequency of these, and the exhaustion that followed the treatment, the patient was compelled to resign the public position which he held, and return home.

When he came under the observation of Drs. Sass and Lincoln, a tumor of the size of a large goose's egg was found on the left side of the neck, in the antero-inferior portion of the region defined by the sterno-cleido-mastoid and trapezius muscles and the clavicle. The trachea was parted half an inch to the right of the median line. The tumor was rounded, smooth, and readily compressible; but after compression it returned to its natural shape.



An attack of indigestion, active exercise, or mental excitement of any kind, would cause the tumor to increase sometimes to twice its usual size.

Sept. 30, 1870, in the presence of Drs. Hammond and Hackley, the patient was anæsthetized and submitted to electrolytic treatment. Four gilded steel needles, insulated to one-half or three-fourths of an inch from their points, were introduced into the four quarters of the tumor; the two upper being one and one-fourth inch apart, and one inch above the lower, which were one inch apart. The two inner needles were connected with the subdivided anode, and the two outer with the subdivided cathode. At first ten, then fifteen elements of a battery similar to Stöhrer's were employed. The strength of the current was increased gradually.

At the expiration of fifteen minutes the two lower needles were disengaged from the current, thus concentrating the whole force upon the two upper; at the expiration of fifteen minutes more the needles were removed.

During the operation all the prominence of the tumor disappeared, and a delicate examination detected a hard mass in its place; not a drop of blood escaped on the removal of the needles. The skin over the tumor presented a bright blush, and the trachea had returned to its proper position. The patient kept quiet for three days, using a cold-water compress. At the end of that time the soreness, which had been considerable, had nearly all passed away.

At the latest date, October 24th, the patient was well, and "the induration in the neck was steadily diminishing in size."

*Goitres.*—Goitres are to be treated by ordinary electrolysis with sharp, bayonet-shaped needles, which may be either insulated or non-insulated. Needles that are smoothly insulated can be inserted through the skin of the neck without very much more difficulty than non-insulated needles; but if the insulation be roughly put in, the difficulty in insertion may be very great. An advantage of non-insulated needles is that by the action which takes place in the skin around it, the needle becomes loosened at the negative pole, and so can be pushed in still further without difficulty. For goitres of all kinds the negative pole is much preferable to the positive pole, just as in cystic and fibroid tumors. There is no danger in inserting a needle even into a small goitre to a considerable depth, say one or two inches. By great carelessness, it would, we suppose, be possible to wound the carotid artery. We do not usually employ an anæsthetic in the operations on the neck; we find that the ether spray, or local application of a mixture of carbolic acid and ether, equal parts, prevents, to a considerable extent, the fear of the introduction, which the patient much dreads, and which is really more severe than the pain of the electrolysis after the needles are in position.

In a few cases we have observed that the needles, when inserted in a goitre, cause, by reflex action, pain in the forehead; in other cases nausea and a tendency to faintness are observed. The majority of

patients do not bear an operation of more than from five to fifteen minutes, which may be repeated two or three times a week.

This purely electrolytic treatment may be varied by external galvanization and faradization with strong currents.

There is no question that external galvanization and faradization with strong currents, both steady and interrupted, will cause a considerable reduction of, and sometimes completely dissipate goitres; and even when these methods do not cause any perceptible diminution, they at least relieve the sense of pressure, the heaviness, and the sense of suffocation, or of choking that goitres often cause. External electrization alone is not as satisfactory as electrolysis with needles.

The prognosis of goitre, under electrical processes, varies with the nature of the tumor. Those which are small and soft may disappear entirely and permanently. Those that are large, provided they are not too hard, may also entirely disappear. The cystic varieties also give a good prognosis. Those that are both very large and very hard may diminish a certain percentage, but they do not entirely disappear. The best method of estimating the results of treatment is to take measurement of the neck. Almost all goitres will go down more or less, and usually at the outset of the treatment. Afterwards they recede more and more slowly; and, even in those cases where the cure is complete, the last quarter will require more treatment than the first three-quarters. This is true of all hard growths that are treated by electricity.

*Goitre of three years' standing—Rapid reduction and approximate cure under galvanopuncture—External faradization with very strong currents.*

CASE CCII.—March 30, 1874. We were called to treat a case of *goitre*, where the measurement around the neck was sixteen and one-half inches. The patient, was a young man twenty-one years of age, and the growth had existed three years. The tumor was moderately but not excessively hard. We commenced treatment with electrolysis, the needle being passed into the centre of the tumor. In one week half an inch was gained; in five weeks one and a half inches, which, in effect, amounted to a cure. We used only mild currents, combined with external faradization, with very strong currents, violently interrupted, as suggested by Meyer. The result, therefore, was due to the combined effect of different kinds of electrization.

The great majority of cases of this kind will become reduced ten, fifteen, or twenty per cent., and will become stationary. Even in this case the reduction of the last quarter inch consumed as much time as all the rest of the cure.

In the above case—which may be regarded as a type of the more successful results of electrical treatment in goitre—the galvanopuncture certainly accomplished more than the external faradization with strong interrupted currents. The latter method did something, and is

worthy of trial in the treatment of goitre in connection with galvanopuncture.

*Simple or adenoid goître in a child aged fourteen—Relief of choking sensations—Steady decrease in size under external galvanization and electrolysis.*

CASE CCIII.—L. W., a girl aged fourteen years, first observed four years since a slight enlargement of the thyroid gland. It rapidly increased in size until December 5, 1871. When she presented herself for examination it was one and a half inches in depth, and two inches in width, reaching to the anterior border of either sterno-cleido-mastoideus muscle. The mass was quite movable and did not in any way cause inconvenience, excepting when she attempted to sing. Iodine, both internally and externally, had been used without appreciable benefit. For the first two months localized *external* galvanization repeated twice a week, was alone tried, resulting in no diminution in the size of the swelling, but in a very decided alleviation of the distressing sensation of strangling, which invariably occurred whenever she attempted to sing.

Subsequently the needles were introduced, and to this date the tumor has steadily decreased in size, until, June 1, it was one-quarter its original size, and the indications were that it would entirely disappear. The needle (a small glover's needle) was introduced some twenty times, but as the pain produced was very slight no chloroform was used.

*Dissipation of a goître of fifteen months' standing under external localized galvanization.*

CASE CCIV.—Miss H., a young lady aged 24, was directed to us by Dr. J. Marion Sims, Nov. 26, 1872.

Fifteen months before she observed in the neck a slight enlargement, which grew with considerable rapidity. On examination, we found a goitre, that spread widely all over the anterior portion of the neck, extending, indeed, beyond the outer margin of either sterno-cleido-mastoid muscle. The measurement around the most prominent portion was  $14\frac{1}{2}$  inches.

We first attempted simple external localized galvanization, with the effect of reducing the measurement in 13 séances to 13 inches. The deformity was now barely perceptible, and decreased with characteristic slowness, but finally completely disappeared after some 15 additional applications. At the close of the treatment, the neck measured just  $12\frac{1}{2}$  inches.

*Cystic Tumors.*—Benign cystic tumors may be successfully treated by the ordinary method of electrolysis. We have treated a number of cases, small and large, and with excellent results. The object of the electrolytic procedure in benign cystics is, of course, very different from the object of the same procedure in nævi. The therapeutical action of the current on cystics is somewhat complex.

1st. The fluid is decomposed. The gaseous products of this decomposition sometimes escape through holes made by the needles.

2d. The walls of the cyst are stimulated, so that the fluid is absorbed, and thus the tumor is caused to shrink. This is, in fact, the rationale of electrolysis in hydrocele.

3d. Decomposition of the walls of the cysts. This takes place, of course, only when uninsulated needles are used. When the needles are insulated near to the end, the walls of the cyst are not acted on.

4th. Evacuation of the fluid contents of the cyst without decomposition. This result may follow puncture of any kind, even when no electricity is used. It is more likely to follow electrolysis with the negative needle, for the reason that the needle, when not insulated, acts on the walls of the cyst, and enlarges the opening made by the needle.

In operating on cystic tumors by electrolysis, the best procedure is to insert a needle connected with both poles. The positive needle may be kept fixed, while the negative is worked in various directions, so as to act upon all the inner surface of the cyst, and also to enlarge somewhat the hole made by the needle in the walls of the tumor, so as to allow free exit of the fluid or gases.

Large, long, cutting needles are usually preferable when the tumor is large ; but for small tumors almost any kind of needle will answer.



FIG. 18a.

Benign Cystic or Erectile Tumor, treated by ordinary electrolysis by insulated needles.

*Cystic tumor of forehead of forty years' standing ; immediate and permanent cure by electrolysis.*

CASE CCV.—Mrs. H., aged 60, we first saw in consultation with Dr. A. W. Catlin, of Brooklyn, Nov. 9, 1871.

For forty years she had been afflicted with a tumor on the forehead, which, in appearance and size, and in its feel and compressibility at the time we saw it, exactly resembled a ripe Isabella grape. This appearance had not, however, been constant ; its size varied, and at one time, after stooping, it had considerably enlarged, and a vein connected with it and leading towards the upper part of the nose became swollen and prominent.

Whether the enlargement was erectile or cystic was a matter of doubt. Dr. A. B.

Crosby, who saw the case with us, regarded it as cystic. The patient had refused to submit to any operation for the radical cure of the tumor—partly on account of fear of hemorrhage, and consequently had worn the unpleasant deformity the greater portion of her life. Nov. 11, 1871, with the assistance of Drs. Catlin, Crosby, Cooper, and Wyckoff, local anæsthesia was used, and two small insulated needles were inserted into the tumor near the base, one pole connected with the positive and the other with the negative pole of ten cells of a portable Galvano-Faradic Co. zinc-carbon battery (Fig. 61). Immediately the color of the tumor began to lighten, through the change of its fluid contents into oxygen and hydrogen gases, and in five minutes the whole surface was almost colorless, and the tumor was much distended. The needles were now withdrawn; there was no hemorrhage, but the gases began to escape at the places where the needles were inserted. Dr. Crosby now used a little pressure, and the tumor flattened with more escape of gas. Under repeated pressure still more gas escaped; and in ten minutes from the beginning of the operation the tumor was perfectly flattened. Gradually the residuum of the tumor disappeared, and in a few weeks scarcely a trace of the long-standing deformity existed.

*Cystic tumor of the breast, possibly malignant, treated by external galvanisation and electrolysis—Great reduction in size, and apparent cure.*

CASE CCVI.—Mrs. P., a lady of middle life, consulted us, December 3d, 1873. The patient had a tumor in the left breast, of the size of a small orange. About two months had passed since it was first observed.

Both her family physician, Dr. Wikoff, and another surgeon of eminence regarded the tumor as scirrhus, and advised its removal.

The patient, we may remark, traced the origin of the growth very directly to a severe bruise of the breast from striking against a bed-post. When we first saw the case, the tumor could be easily felt and grasped between the fingers, and seemed quite hard. The nipple was but slightly affected, and there was no involvement of the glands in the axilla.

There had been little or no pain, the tumor had not extended to the skin, and there was no discoloration; except by examination the presence of the growth would hardly have been suspected. The growth was quite movable.

The patient was of a very nervous temperament, and had suffered much from neuralgia. In spite of the lack of very severe symptoms, we concurred in the opinion of her previous advisers, that the tumor was scirrhus. The patient so dreaded the thought of the knife that she wanted to give electrical treatment a good trial.

We began with local external galvanization with moderate currents. After one week's treatment the tumor seemed looser, softer in portions, and a trifle smaller. Subsequent treatment added nothing to this apparent improvement. We therefore resolved to use galvano-puncture.

December 31st, we inserted two needles into the part of the tumor that was most superficial; one needle was connected with the positive and the other with the negative pole.

Ether spray was used before the needles were introduced. The needles had not been in position more than five minutes when a fluid as colorless as water began to flow out of the places where they were inserted, and on pressure the quantity that came away was much increased, and more or less flowed out during the whole operation, which lasted fifteen minutes.

When the needles were withdrawn, and pressure was used, still more fluid exuded, and the tumor had become reduced two-thirds in size. The tumor was evidently *cystic*.

January 2d and January 8th, we again operated with Dr. Beard's long cutting-needle, without assistance and without anæsthesia, so as to reduce the tumor to a minimum, and if possible cause absorption or atrophy.

At the second operation a less quantity of fluid exuded, and still less at the third operation. The patient left for home. We occasionally hear from her, and, up to the date of writing, the tumor has not resumed its original size, and does not in any way trouble her.

In the above case one of three results are possible :

1st. The tumor may remain comparatively small, causing no annoyance to the patient. This result we have seen in other cystic tumors (though not in the breast), from the same method of treatment that was adopted in the present case.

2d. The tumor may again fill up with fluid, and may require a repetition of the same treatment.

3d. It may take on the scirrhus form. It is, of course, possible that the walls of the growth may already be of a scirrhus character. Even if it should prove to be a scirrhus growth, it would not follow that removal would be at once indicated.

If in the above case there should ever be a rapid and ugly recurrence of the tumor, with threatening indications of any kind, the method of electrolyzing the base would be indicated, the knife or the galvano-cautery being used to remove the body of the growth.

*Cystic tumor of the submaxillary region, probably malignant ; three operations—Electrolysis of the base—Rapid healing with slight disfigurement—Permanently successful result.*

CASE CCVII.—Miss —, a young lady in her teens, was sent to us March 25, 1872, by Dr. Wm. W. Reese. The patient was of a fragile constitution, and had become debilitated by confinement in the stifling air of a manufactory where she was employed. For one year she had been troubled with a tumor on the submaxillary region of the left side, that was at first supposed to be simply an enlarged gland. It did not, however, yield to the usual treatment that various physicians and surgeons had given her, and at the time we saw it, it was about the size of an English walnut, and was apparently encysted. Lancinating pains of a tolerably severe character were sometimes felt in and near the growth.

Careful examination made it pretty clear that the enlargement was cystic ; that a soft substance was inside of it, although the walls were quite hard. March 27th, with the assistance of Drs. Reese and Hyde, we electrolyzed a portion of the growth, and found that it was really cystic and contained a dark, cheesy substance. The patient was fully etherized during the operation, which lasted forty minutes. Large and long needles were employed, and sixteen zinc-carbon cells.

The operation was followed for two days by irritative fever, but by no other unpleasant result. There was considerable sloughing, but the bulk of the growth remained as a large unsightly mass. April 14th, we again operated by *working up the base* of the tumor, undermining it and separating it from the surrounding healthy tissue. Dr. A. B. Crosby assisted at the operation, and enucleated a portion of the mass before the needles were inserted. The irritative fever was slighter than after the previous operation. An ulcer  $1\frac{1}{4}$  inches in length and a half an inch in depth remained—the surface presenting, as usual after electrolytic operations, a charred appearance which at first alarmed the patient. The subsequent healing was, in the judgment of all the surgeons, surprisingly rapid and satisfactory. Dr. Crosby, in proper time, brought the edges together, and thus expedited the reparative process, so that at the end of a month only a trifling scar remained. At one of these operations the parenchymatous hemorrhage was excellently controlled by the action of the current, and no other styptic was required. The patient had now positively improved in her general health, and was free from any sign of the disease. It was hoped by all parties that she would hear no more from the tumor. It had been suspected at the close of the operation that a small portion of the growth remained, but it was not deemed advisable to protract the operation.

Very soon pains of quite a severe character began to be felt just beneath the skin in the region of the sublingual gland; then followed swelling, and in a few weeks a tumor as large as a horse-chestnut, of the same appearance and feel as the previous growth. We decided to operate again, this time with absolute thoroughness; the same surgeons being present. Dr. Crosby made an incision and enucleated the growth, the operation being completed by electrolyzation with large needles as before.

*The work was thoroughly done; the base was thoroughly electrolyzed* (Fig. 193). During the operation, a branch of the facial artery was severed by the needle; this was tied by Dr. Crosby. The wound was treated as before and with the same result—rapid and satisfactory healing, that has been permanent. The scar disfigures but slightly, while the patient has improved in her general health, and at the date of writing, three years after the last operation, weighs much more than at the time of the operation.



FIG. 183.

Electrolysis of the base of the malignant cystic tumor of the neck, after removal of the tumor by enucleation. Long negative needle manipulated by the operator; connection made by a similar positive needle also in the base.

The above was one of the earlier cases *in which the method of electrolysis of the base was employed.*

Unfortunately the tumor was not examined by the microscope. The evidences of malignancy of the tumor were its recurrence, after enucleation and ordinary electrolysis, the facts that it seriously affected the general health of the patient, and that her health greatly improved when the tumor was finally removed.

*Hydatids of the Liver.*—Durham and Forster\* have treated eight hydatid tumors of the liver with success by electrolysis at Guy's Hospital and the Royal Infirmary for Children, Waterloo Road.

"In one patient, who was under the care of Dr. Hilton Fagge, and who was operated upon by Mr. Durham in June, 1868, the dulness in the hepatic region measured seven inches vertically, the ribs on that side were bulged, and the intercostal spaces prominent. Two needles were introduced into the most prominent part of the swelling, one piercing the space between the eighth and the ninth costal cartilages, and the other about two inches behind it, between the ninth and tenth ribs. The needles passed in to a depth of two or three inches. One of them was evidently free in the fluid, for it could be moved about and rubbed against the other. The posterior needle doubtless passed through the diaphragm, as it was jerked about by the respiratory movements. Both needles were connected with the negative pole of ten cells of the battery, freshly charged. The positive pole, connected with a moistened conductor, was placed between and near the needles. The current was allowed to pass for twenty-five minutes, and during this time there was a crackling feeling under the finger as of emphysema, owing to the development of hydrogen from the liquid of the cyst. After the operation there was some pain for four or five hours. In the evening the temperature was 100.9°, and the patient did not sleep well that night. Next day the temperature was 99.6°, and on the morning after it had risen to 101.2°. At this time the hypochondriacal tumor had greatly disappeared, and the man expressed himself as feeling quite well. On examining the right side of the chest, however, Dr. Fagge was a little startled at finding absolute dulness behind, up to the fourth or fifth dorsal vertebra; and over this extent of thorax there was less vocal vibration, marked tubular respiration, and ægophonic character of the voice, which afforded conclusive evidence of a large effusion of fluid. There was very slight pain about the points where the punctures had been made, but no pleuritic pain. The man lay on his back, and was quite comfortable. The liquid had evidently been squeezed through the puncture in the diaphragm into the pleural cavity. The man went on perfectly well, and the chest symptoms disappeared entirely. Twenty days after, all traces of the abdominal tumor had disappeared."

*Fibroids.*—Fibroids are usually hard, and therefore slow to decompose under electricity. This is true of all fibroids, wherever situated,—in the neck or any portion of the periphery, or in the uterus. Inasmuch as they are not usually malignant, the method of electrolyzing the base, hereafter to be described, is not needed. They are to be treated by ordinary

\* Althaus, op. cit., p. 645. See also *Med. Times and Gaz.*, Nov. 19th, 1870.



electrolysis, needles connected with both poles being inserted in the tumor. The needles may be insulated or non-insulated, according to the situation of the tumor.

The behavior of fibroids after electrolysis is not generally satisfactory ; the amount of decomposition, on account of the density and comparative dryness of the tissue, is but slight ; and the subsequent shrinkage and atrophy is not so marked as in goitres or cystic growths.

If a current of sufficient strength be used, the patient being anæsthetized, suppuration may be excited, and, as a result of the destruction and loss of tissue, the tumor may become somewhat smaller.

*Recurrent fibroid tumor of a year's standing—Repeated Electrolyzations without etherization and attended with trifling pain—Arrest of Growth—Gradual decrease in the size of the tumor.*

CASE CCVIII.—Mrs. P., a lady of middle age, was directed to us by Dr. F. Winston in February, 1871.

On examination, we found under the right ear a large tumor, soft and movable, and equal in size to the closed fist. The enlargement was of the recurring fibroid character, entirely painless, but most unsightly in appearance. The patient first observed the growth some ten years since, when its size was barely appreciable. It gradually enlarged until it attained the size of an ordinary hen's egg, and was removed by the late Dr. Cheese-man.

A few months subsequently it made its appearance a second time, and steadily enlarged, until at the expiration of three years its size was somewhat greater than when the first operation was performed.

It was again removed by Dr. Willard Parker, but in course of time returned. The patient was now unwilling to have the operation by the knife repeated, and for seven years the tumor slowly increased to the size above stated.

To avoid any possibility of exciting an action in the tumor that might render it truly malignant in character, we at first made use only of external galvanization.

After a dozen applications no change could be perceived in its outward conformation ; but that the treatment had not been without some effect was manifested from the fact that the head could now be turned in any direction without causing the disagreeable and sometimes painful sensations that had formerly followed pressure of the deep portion of the growth on the underlying tissues.

We now decided to try the ordinary method of electrolysis, and accordingly introduced, an inch into the tumor, a needle insulated to within half an inch of its point. The application, alternating with external galvanization, was repeated some twelve times during the course of two months, and resulted in a very decided alteration in the shape, as well as a marked diminution in the size of the growth. After each operation a large quantity of free hydrogen gas escaped through the opening made by the needle, followed by a slight flow of blood.

At this time two needles were used—the second one of platinum, and connected with the positive pole. It should be stated that previously only twelve zinc-carbon cells had been used, and the current allowed to pass but ten minutes. We now increased the cells to twenty, and permitted the needles to remain some fifteen minutes ;

but when they were withdrawn, neither gas nor blood escaped, and yet it was absolutely certain that the current had been passing every moment, and with power greater than in previous operations.

In a few hours the tumor and tissues surrounding it became greatly swollen, accompanied by very considerable pain.

The pain and swelling were relieved by a poppy poultice, but a slight discharge continued through the months of July and August, during which time treatment was intermitted. In September, when the patient returned to the city, the discharge, which had ceased two weeks previously, had evidently resulted in a still further reduction of the tumor.

The treatment was resumed, and continued at intervals during the ensuing winter and spring. The effect was a slow but constant decrease, until it was reduced to about one-third its original size.

At one time during an interval in the treatment the patient observed, in a portion of the tumor to which the needles had not been applied, a projection which rapidly enlarged until it was one-third of an inch in diameter, and extended downward into the healthy tissue for more than an inch. A single needle was introduced into this unwelcome addition, and a mild current allowed to pass for ten minutes. The process of absorption was excited, and in two weeks this protuberance completely disappeared.

It is interesting to note in this description, that while the growth was slowly but steadily enlarging before the use of needles, it did not, after the treatment by electrolysis was begun, show the slightest disposition to increase in those parts actually influenced by the current—although at one time several months elapsed between the operations. Subsequently what remained of the tumor was again removed by Dr. Parker.

While the above case cannot be cited as a brilliant result of electrolytic treatment, it is of exceeding interest, and has afforded many useful hints that have been of value in other cases. The pain of introducing the needles was trivial; and the electrolytic action, even when it was very intense, produced little or no sensation; consequently it was at no time necessary to use chloroform, and the treatment was as readily borne as if the applications were merely external.

*Fibroids of the uterus* are of sufficient importance to be specially considered. They may be treated electrolytically, either through the vagina or through the abdominal walls, according to the position.

The danger of creating peritonitis by thrusting needles through the abdominal walls is but slight; and if the needles are well insulated by rubber, there is really no danger. The insulated part should, of course, go beyond the peritoneum.

Dr. Kimball, of Lowell, reports excellent results from treating fibroids in this way. Our own observations in this direction have not been of the most encouraging nature. We have never seen a large and hard uterine fibroid disappear under electrolysis. Relief of pain, of neuralgia and anæsthesia, and of many of the attending symptoms, we

have many times obtained, but never a complete or approximate dispersion of the tumor.

*Lipomata (Fatty Tumors).*—Ordinary surgical treatment with the knife is so successful for fatty tumors, that electrolysis would hardly be indicated, even if it could accomplish as much and as easily as the knife. Fatty tumors are, of course, benign; and when operated on do not recur. Fat decomposes slowly and with difficulty, and from our first experiments on a number of fatty growths, we were led to believe that secondary absorptive effects would not, as a rule, follow electrolysis. Dr. Rockwell's later experience, however, in this direction, has been more satisfactory. By using an increased number of needles, more powerful currents, and by prolonging the operations, several of these tumors have been completely dissipated. In every case the operations were rendered entirely painless by the use of the ether spray.

*Ovarian Tumors.*—The electrolytic treatment of ovarian tumors has of late excited much attention, and we can do no better than to give briefly the conclusions arrived at by Dr. Paul F. Mundé, in a very creditable *resumé*,\* of what has been attempted and accomplished in this department of electro-surgery.

He finds: 1st, "That a number of ovarian tumors, reported on reliable authority, have been completely cured or permanently improved by electrolysis—out of fifty-one cases, twenty-eight or about fifty-five per cent.

2d, "In a number of these cases electrolysis was followed by dangerous (thirteen, or 25.4 per cent.) and even fatal results (nine out of these thirteen, or 17.6 per cent. of the whole fifty-one.

3d, "Further, six cases out of fifty-one received neither benefit nor injury from the treatment, and four were only temporarily improved; total, ten, or 19.6 per cent. We thus have a total of twenty-three cases, or forty-five per cent., in which the electrolytic treatment failed to accomplish the object for which it was administered. . . .

6th, "Notwithstanding these undoubted cures, the percentage of successes of oöphoro-electrolysis (55 per cent.) compares unfavorably with that of ovariectomy (70 to 80 per cent.; Spencer Wells 78 per cent., in 1876 as high as 91 per cent.). And so also do the deaths by electrolysis (17.6 per cent.) nearly equal those following ovariectomy in recent years (20 to 30 per cent. to 22 per cent.), and far exceeding those occurring in the last series of fifty-five cases of Spencer Wells (five, or 9 per cent.)."

\* "The Value of Electrolysis in the Treatment of Ovarian Tumors," by Paul F. Mundé, M.D., New York, Gynæcological Transactions, 1878.

*Polypi.*—Naso-pharyngeal polypi have been treated by a series of electrolytic operations with success. Von Bruns records a notable case of this kind. As a rule, however, it would be difficult to entirely cure a naso-pharyngeal polypus by electrolysis, and the treatment would be very annoying. Polypi in accessible localities are best treated by the galvano-cautery wire-loop.

*Epithelioma, Scirrhus, and other Malignant Growths.*—Malignant growths may be defined clinically as *those growths which are liable to recur after removal.*

Under this head may be classed epithelioma, recurring cysts and fibroids, encephaloids, scirrhus, and so forth. If tumors of this kind are to be treated at all by electricity in the hope of permanent relief, it should be by the method of *electrolysis of the base* as already described, provided, of course, the tumors are sufficiently accessible.

Pain may, however, be relieved, and in some cases a reduction in size may be gained by the ordinary method of electrolysis, or by simple external galvanization or faradization; and by *these methods also the tumor may be arrested in its progress perhaps for a long time.*

Of the different forms of malignant growths, the best prognosis for a permanent cure, or for a long deliverance, is in recurring cysts and fibroids; next would come epithelioma, of which we have successfully treated a number of cases, and last of all scirrhus.

Cancers of the neck of the uterus have been removed by galvano-cautery, but not, so far as we know, by electrolysis of the base.



FIG. 184.

Removal of epithelioma of face by electrolysis of base. Both negative and positive needles inserted in the healthy tissue *beneath* the tumor.

*Epithelioma of the face, originating in an old scar, six months' standing, removed by a combination of electrolysis of the base and the galvano-cautery.*

CASE CCIX.—Captain D. was brought to us, April 27, 1873, by Dr. Fessenden. The patient had a tumor that appeared to be an epithelioma, about the size of a small walnut, over the zygoma. It had developed from an old scar that had

existed from childhood. When he was first brought to us the tumor had been in existence six months. It had been treated by caustics, but rapidly recurred. We decided to treat the tumor by *electrolysis of the base*, combining with it the galvano-cautery, if necessary or convenient, in order to shorten the operation.

April 30th. We operated, assisted by Dr. Fessenden, who gave the anæsthetic for ten minutes, with eighteen zinc-carbon cells. We used the long cutting needle, passing one connected with the positive pole *under* the tumor near the edge, and another long cutting needle connected with the negative pole, also under the tumor, and parallel to the positive needle. The electrolytic action was moderately strong, and the growth was rapidly loosened. The positive needle became fixed in the tissue where it was imbedded, through the oxidization, as is always the case with the positive needle, while around the negative needle a yellowish foam appeared, caused by the mingling of the hydrogen evolved with the blood. The needle was very loose in the tissue, and we worked it slowly to the right hand and left until the tumor was undermined by the electrolytic action, and nothing remained but a portion of the skin. We completed the operation by a short wire connected with Byrne's galvano-cautery battery. After the tumor was removed, we worked up the base, partly with the needles and partly by the heated galvano-cautery wire.

Both needles, positive and negative, were plunged into the base and edge of the tumor, into healthy tissue, until all was bloodless, charred, and dry. Scarcely any blood flowed during the operation.

The patient was soon able to leave the operating-room. Cold-water dressing only was used. Some sloughing followed, and satisfactory granulation. In six weeks the sore had completely healed, with a moderate cicatrix, and at the date of writing, Sept. 1st, 1874, seventeen months from the time of operation, there are no signs of recurrence. The growth was examined microscopically by Dr. Ormiston, and by him pronounced malignant.

*Large and painful epithelioma of the upper lip of several months' standing—Removal by ordinary electrolysis and the method of working up the base—Satisfactory healing.*

CASE CCX.—Miss —, aged 20, was brought to us by Dr. Corey, October 23, 1871, to be treated for an epithelioma of the upper lip that had distressed her for several months. At this time the growth extended from the median line to the left corner of the lip, being about one inch in diameter and one-half an inch in length. The pain of the growth was at times very great, especially when exposed to the cold; the disfigurement was annoying, and there was an evident tendency to quite rapid increase. At the base, on the inner surface of the lip and especially at the corner, hard nodules were easily detected by the finger. With the assistance of Dr. Corey, and in the presence of a number of physicians, we electrolyzed the upper portion of the growth with five small needles, three connected with the negative and two with the positive pole. Full anæsthesia was used, and the operation lasted twenty minutes. The needles were inserted directly into the body of the tumor and not around the base. The method of working up the base, we had not at that time begun to employ. The soft parts of the tumor in the vicinity of the negative pole decomposed with rapidity. A yellowish foam was developed, which, forcing its way underneath the scab that covered the tumor, gradually lifted it up and completely detached it from the body of the growth.

The parts presented the usual charred appearance after the operation, but there was little or no pain, either in the tumor or in the vicinity. There was, however, considerable irritative fever, and the face was somewhat swollen. In the course of a week, the portion of the diseased part that had been electrolyzed began to contract, and near the median line healthy tissue appeared. The lower part, that was little affected by the needles, remained as before. Nov. 9, we again operated by the method of electrolysis of the base with four negative and one positive needle with the same number of cells (sixteen zinc-carbon) and for about the same time. Dr. Corey administered the anæsthetic, and Drs. Armor, Caldwell, and others were present. This operation was more thoroughly performed than the previous one, but the needles were not inserted into the nodules or the inner surface, but only into the superficial parts of the growth. No bad result followed, and by Nov. 27th the tumor had contracted to one-third of its original size and was healing rapidly. The healing process continued until scarcely any trace of the disease remained. The healing was almost perfect; there was an entirely natural skin in the region where the tumor had formerly existed, and the only cicatrix was at the corner of the mouth. Twitches of pain have been felt in the vicinity of the scar, especially on exposure to cold, giving rise to the suspicion that possibly that portion of the growth was not thoroughly treated.

It is now three years since the patient was treated, and the recovery may be regarded as most satisfactory. In reference to this case it may be remarked:—

1. If the diseased mass had been thoroughly separated from the surrounding healthy tissues by inserting large needles, one operation would have been sufficient, and the cure would probably have been absolute. This was the first case of the kind that we had treated, and we had not then employed the method of working up the base, and had not devised the long, sharp, double-edged needle which we now employ in the electrolyzation of large growths.

2. There was scarcely any hemorrhage or other unpleasant symptoms during or after the operation, excepting the irritative fever of which we have spoken.

*Epithelial cancer in a lady aged thirty, involving the rectum, vagina, and external parts—Eleven operations by ordinary electrolysis and electrolysis of the base remove the growths, alleviate pain, and modify very greatly the rapidity with which the disease subsequently reappears—Subsequent treatment by galvano-cautery by Dr. Byrne, with relief—Death of the patient.*

CASE CCXI.—The wife of a physician, aged about 30, had for eight years of her married life suffered from what was supposed to be scirrhus of the rectum, which had been removed by ligatures at different times and by different surgeons.

About three years before we saw her, an epithelial cancer appeared at the entrance of the vagina; this gradually increased in size and protruded, until October, 1871, it appeared to be about one-half as large as a cauliflower, and much resembled one in

appearance. The discharge was very profuse and very offensive ; the pain terrible and almost constant. The growth was evidently increasing, and only with difficulty could the patient walk about the house.

A more distressing case of disease of any kind we had never seen. After each removal of the mass by the ligature, it would spring up almost before the sight and become larger than before. There was about it a rankness, a fierceness, a malignity, quite unusual. Like rampant weeds in rich soil, the more it was cut off, the faster it grew. Escharotics of all kinds, as well as cundurango, had been tried, the latter remedy seeming to do injury.

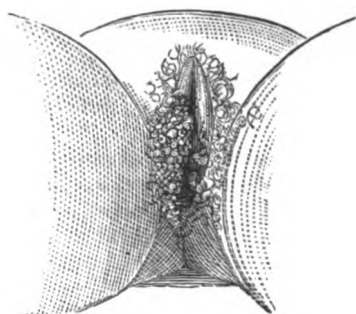

FIG. 185.

Epithelioma of the vagina and vulva. Cauliflower appearance.

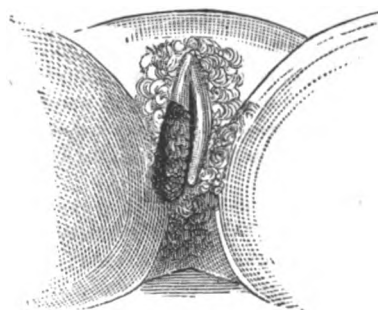

FIG. 186.

Appearance of granulating base after removal of a portion of the epithelioma of vagina and vulva by electrolysis.

The galvano-cautery had been suggested by Dr. E. R. Peaslee, whom the patient consulted, and Dr. Byrne had intended to give it a trial, but deferred the operation in order to experiment with cundurango. We began treatment with external galvanization in order to relieve the pain. The first treatment accomplished nothing ; the third treatment, we connected an insulated rectal electrode with one pole, while the

positive, by means of a wet cloth, was gently passed over the very sensitive surface of the tumor. The patient was relieved of pain for a whole night. Satisfied with the result, we now resolved to use the needles.

With the assistance of Dr. Rotton and the husband of the patient, we operated eleven times, with intervals of two or three weeks between the *séances*. Full etherization had been obtained in each operation.

We used two, three, or four needles, according to circumstances, and both poles were inserted into the base of the growth.

The first operation, Oct. 20, which lasted twenty-five minutes, removed one-third of the growth; and by the end of the third operation, all the growth external to the orifice of the vagina was removed.

Far up in the vagina the diseased portion could readily be detected, spreading out in all directions like a watermelon vine.

Nov. 15th, there was some evidences of a reappearance of the external growth in those parts that were not thoroughly electrized. Nov. 22d, operated again by electrolysis for half an hour.

Dec. 5th, operated again by electrolysis in connection with Dr. Byrne, who by the aid of his speculum applied the galvano-cautery to the portions of the growth in the vagina. Jan. 17th, again operated by the same method for thirty minutes. The external ulcer caused by the removal of the tumor had hitherto been about four inches long, three inches wide, and one inch in depth, extending from the middle of the labia beyond the anus on the right side.

This ulcer now began to heal at the edges and to contract. Jan. 6th, began the use of nitrate of silver, applied to the ulcer. Jan. 8th, the discharge which had come from the vagina was much diminished and the ulcer had contracted to half the original size. Jan. 21st, operated by electrolysis in the vagina chiefly.

March 24th, repeated the operation with long needles, in the vagina, on some ragged portions of the growth. We were now able to ascertain by digital examination that there was a pretty direct connection between the growth in the rectum and the one in the vagina; they seemed, indeed, to be extensions from a common centre.

The septum at the base of the tumor in the vagina was so thin that we much feared a recto-vaginal fistula, and great care was necessary in operating, to preserve this delicate and partially disorganized tissue that separated the two canals. April 21, again operated by electrolysis.

Subsequently the actual cautery was once used, in the hope that perhaps it might cause a more thorough drying up of the profusely discharging surface in the vagina; but the results of its use were unsatisfactory. The febrile condition that followed was alarming, and the local pain was terrific for several days after the operation. During the summer, local applications of various kinds have been experimented with; among others, a mixture of iodine, iodide of potassium, and glycerine, which was employed at the suggestion of Dr. Byrne, and with good effect.

During the year the patient had taken cod-liver oil, and except by intervals has had a good appetite. Twice a severe and protracted attack of sciatica has been brought on, apparently by exposure to cold.

At one time the patient was confined to her bed, and was somewhat hysterical. During the summer the external part of the growth gradually reappeared, but there was no difficulty in urination or defecation; and hence we conclude that the portion in the rectum has not greatly enlarged, and at the last examination the condition of



the vagina was not seriously altered. We have all along feared that the disease would extend to the uterus, but examinations made at different times gave no evidence of involvement of that organ.

The operations were performed with a zinc-carbon battery of eighteen cells, freshly charged.

The constricting power of the current was observed at both poles, but most decidedly at the positive. After each operation the surface presented a dark and somewhat charred appearance, as though it had been slightly burned. No large artery was severed during the operations, hence it was not necessary to use either the ligature or persulphate of iron. During the winter of 1873 Dr. Byrne twice operated on the external portion of the growth with the galvano-cautery. The result was a most satisfactory healing of the external ulcer. This healing was much more permanent than the healings that followed electrolysis.

We have given the above case in considerable detail, because of its great interest to surgeons, and especially because it illustrates most vividly at once the value and the limitations of electrolysis in malignant tumors. It illustrates :

1. The power of electrolysis to control hemorrhage. The growth was so vascular that it bled quite profusely on the slightest touch, and yet, under the various and protracted electrolytic treatments to which it was subjected, the amount of blood lost was but a trifle.

2. The fact that the electrolytic treatment does not cause shock, to the extent that similar destruction of tissue by other methods would be likely to do. Twice, when chloroform was employed as an anæsthetic, the pulse acted badly and compelled us to suspend the operation sooner than we desired ; but under etherization the needles were used for half an hour and longer without causing any shock. The stimulus of the current, with the occasional interruptions that are required, seemed, by reflex influence on the central nervous system, to act as an antidote to shock, as it has appeared to do in other cases.

3. Better healing, and later reappearance of the growth than after the operation by ligature and caustics. When removed by ligature this growth sprang up with great rapidity—in the course of a few days ; even before the eyes, as it were, it seemed to enlarge, and to develop an offensive discharge ; and the base never began to heal, even on the edges. After thorough electrolysis of the base, this growth not only did not show signs of recurrence for several weeks, but an external ulcer of large size entirely healed. With the internal ulcer on the feebly organized mucous tissues of the vagina we were not so successful.

4. The severe irritative fever that sometimes follows electrolysis. After all the operations, the patient was confined to her bed for several days, and was more or less distressed by inflammation and swelling, not

only on the edges of the ulcer, but at some distance down the nates and through the labia. The swelling of the labia was so great that difficulty and pain were experienced in passing water. It should be noted, however, that after the operations with the galvano-cautery and the actual cautery, the irritative fever and surrounding inflammation were much more decided and distressing, and for that reason we returned to electrolysis.

5. The utter inability of even the most thorough and repeated electrolyzations of the base, to permanently eradicate the growth in those parts where it was *connected with the mucous membrane*. Although *the base was thoroughly worked up* by inserting the needles into the healthy tissue surrounding it so as to completely cut off all communication between the natural and morbid parts, yet the disease extended *from the vagina*, until quite distant parts were attacked and became saturated with cancerous degeneration. The *external* portion of the growth connected with the perineum and nates was apparently eradicated as thoroughly and as successfully as the cases of epithelioma of the lip, previously reported, and the subsequent reappearance of the growth was due to the extension of the disease from the vagina, which part could not be thoroughly affected by electrolysis.

6. The comparative value of electrolysis and galvano-cautery. The healing after electrolysis was incomparably more satisfactory than after the ligation; but in the course of months the growth returned, apparently by extension from the vagina. The irritative fever that followed the electrolytic operations was not observed to any marked degree after the use of the galvano-cautery, and more time elapsed before recurrence.

Take the case all in all, its long standing and wide extent, its excessively rapid growth and still more rapid reappearance after operation by ligation, the frequent repetition of long electrolyzations, and the temporary benefit resulting therefrom, and the opportunity it afforded for comparing the advantages of electrolysis and galvano-cautery, it may probably be regarded as without a precedent in electro-surgery.

*Two general varieties of cancer of breast.*—In their relations to electro-therapeutics there would appear to be two general varieties of tumors of the breast; one variety in which all or nearly all the mamma is involved, and which is very hard, firm, and unyielding, the skin being tense, glossy, and indicating inflammation and induration. The variety is more obstinate and unyielding; the pain may be relieved, but the tumors do not grow smaller under the action of the current; they can be diminished in size or removed only by actual destruction of the tissue.

In the other variety the tumor involves but a limited portion of the breast; the skin is not tense, but is soft and yielding, and of the natural color; the growth is felt as a nodule beneath the skin, and the pain is not usually so severe as in the other variety, and the growth is much slower. This variety is the one that is most disposed to yield to electrical treatment. Not only is the pain relieved, but the tumors grow softer and smaller. In other cases their advance is arrested by the treatment, so that they remain stationary for months or years.

Whether what we call, for convenience' sake, and for clinical reasons, only two varieties, are really but different stages of one variety; whether the latter may sometimes come under the head of abscess, or of the atrophying cancer described by Billroth—these questions we resign to the pathologists of the future.

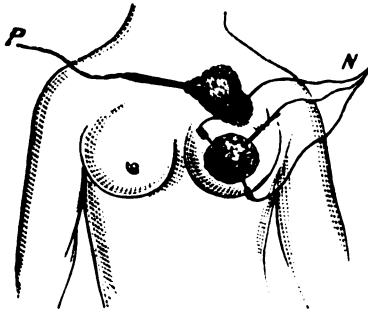

FIG. 187.

Scirrhus of the breast treated by ordinary electrolysis. Three needles connected with negative pole in body of tumor; connection made by a sponge, the positive pole at the indifferent point on the lupus.

*Scirrhus of the left breast in a woman aged forty-five—Complete and instant relief from excruciating pain, and in the course of four days disappearance of one-half the growth from one electrolytic operation—Retrocession of the disease to the bowels, resulting in death.*

**CASE CCXII.**—Mrs. —, aged about 45, an inmate of Bellevue Hospital, was affected with cancer of the left breast.

The main portion of the scirrhus was the size of an ordinary orange, and extending into the axilla were a number of cancerous nodules of considerable size.

The surrounding and intervening tissue was as hard and unyielding as the tumor itself. The process of suppuration was beginning to manifest itself, and for several weeks the patient had suffered night and day the most excruciating pain through the diseased parts. The first operation was performed in one of the wards of the hospital, in the presence of Prof. Frank H. Hamilton (who had requested us to operate by the electrolytic method) and his private class. The patient having been etherized,

we introduced deeply into the upper portion of the breast three gilded needles, and with a fourth transfixed the largest of the axillary nodules. The positive pole (a large moist sponge) was applied to the under portion of the gland. No very decided change was manifest in the appearance of the mass during the operation other than some puffing up of the skin, due to the disengaged hydrogen; but very soon after it began to decrease in size, and in one week not only had all the hardness of the surrounding tissue and all the axillary enlargements entirely disappeared, but the mammary tumor had decreased in size at least one-half. The most grateful relief the patient experienced, however, was the complete and seemingly permanent dissipation of pain. In ten days we again operated, and by the same method, in the amphitheatre and before Dr. Hamilton and the regular class of the college. On the following day the patient felt so comfortable that she left the hospital, and in a week's time presented herself for examination, when it was found that there had been a still further decrease in the size of the tumor. She still remained entirely free from pain, and was delighted with the results of the treatment. Most unfortunately, we now lost sight of the patient; but a few months subsequently she returned to the hospital, suffering from malignant disease of the intestine, of which she died.

The following is a condensed report of a case treated by us in cooperation with Dr. A. B. Crosby. We give it substantially as detailed by him: \*

*A case of scirrhus of the rectum—Relief of symptoms—Satisfactory healing—Death.*

CASE CCXIII.—Mrs. L., aged 60, a lady of a nervous, but, on the whole, of a healthy temperament, came under our care Nov. 7th, 1871. For three years she had been suffering from a tumor of the rectum that was evidently of a malignant character—such at least had been the opinion of the large number of physicians and surgeons who had seen the patient. Bougies were frequently inserted and various remedies had been tested—among others cundurango, which the patient thought afforded some relief. On examination, it was found that the growth extended about three inches up the rectum, forming a hard ring and a stricture so narrow in the upper portion as hardly to admit the end of the index-finger. The patient was tormented with flatulence, and the distress in the region of the tumor and of the nerves that supplied it was very great. The pain in defecation was severe, and the passages were small and very frequent. She was able, however, to go about the house more or less, and occasionally rode out.

We began treatment by localized galvanization externally by various forms of rectal electrodes. By these applications, there was a decided and grateful relief of the pain and of the flatulence. This relief continued so long as this method of treatment was used.

January 7th, 1872, Dr. Crosby ruptured the sphincter with the assistance of Drs. Reese and Ostrander, who administered ether. We operated with a zinc-carbon battery on these protuberances by the ordinary method of electrolysis. The usual small needles were used. The operation was followed by some irritative fever, but the patient, on the whole, bore it excellently, and the whole growth was relaxed so that

\* Archives of Electrology and Neurology, May, 1874.

the passages were easier. Three weeks after the operation the patient was very much better, and went round the house.

The operation, which lasted forty minutes, including intermissions consisted in inserting one needle connected with the positive pole into the body of the growth, while the negative needles were run through the base and made to *work around* the inside of the rectum at the base of the tumor, as far as it was deemed prudent to go. The growth was mostly removed in this manner, and with very little hemorrhage. The entire thirty-two cells were employed, and the patient was kept under ether for two hours. Irritative fever followed the operation for five days. The pulse went up to 120. There was some flatulence and pain in the abdomen, but no positive tenderness. There was considerable urethral irritation and dysuria, and the urine was drawn by a catheter.

In a few days, the patient was able to discharge large and well-formed fæces. For about a month, there was some discharge from the rectum, but no symptoms of pyæmia, or of peritonitis or of cellulitis that might be feared from so formidable an operation.

From May to June there was but little pain in the rectum comparatively, and the patient was able to walk about and to go out.

May 15th, the patient rode out with comfort, and she strongly hoped that the relief would be permanent; but there were signs of a recurrence of the growth, increasing stricture and induration, and the fæces gradually became smaller.

During all this time, Dr. Crosby was in the habit of introducing sponge-tents of good size about every week or ten days.

Dr. Crosby being called away July 1st, Dr. George K. Smith was called in, and suggested the use of ox-gall injection to soften the fæces. This suggestion was acted upon with good results.

The patient, who was subsequently seen by Dr. Colton, gradually grew weaker during the excessive heat of the summer, and died October 27th, 1872, apparently from exhaustion.

Dr. Crosby thus epitomizes the important features of this case in its electro-surgical aspects:

“That this growth was malignant was evident from the history of the case and all the symptoms, and was established by the microscopic examination of Dr. Spier. I am disposed to believe that if the tumor had been in a position where it could have been more readily reached, and where the *whole* growth and *the adjacent parts* could have been thoroughly electrolyzed, the results would have been very much better. As it was, it seemed unjustifiable to interfere too seriously with the gut, lest we might destroy it and produce recto-vaginal fistula.

“The stricture extended upward, about three inches above the anus, and ranged from three-fourths of an inch to an inch in breadth.

“It was only at one point anteriorly that it extended higher than three inches. At this point, a little indurated tissue could not be removed without endangering the recto-uterine pouch of the peritoneum.

“Whatever, then, might have been hoped in case the removal had been absolutely complete, it was certain that the disease must continue to develop in this particular case. Anatomically, three inches of the rectum—that is, that portion within the perineum—may be safely removed by the knife even. In the above case, the spear-pointed electrodes brought away a large annular mass of scirrhus when the operation was performed. ●

“This was followed, a few days later, by the separation of a large annular slough, and the rectal wall was left soft and free from disease, except the small, indurated spot that extended above the floor of the pelvis and could not be safely removed. It is a fair question whether if the operation had been done earlier, radical improvement might not have followed.

“A point of practical convenience was seen in the method adopted to reach the stricture.

“I first completely ruptured the sphincter ani, so as to induce complete relaxation. A piece of two-inch lead pipe, about two inches in length, with a handle soldered on one side, made an excellent speculum, which was pushed up to and brought the stricture fully into view.

“Through this, it was possible to carry the spear-shaped electrodes through the stricture with ease and certainty, and move them freely around the circumference of the bowel.

“This case showed, what I have witnessed in other cases treated by electrolysis, no primary shock.

“The irritative fever which followed was very marked for some days, but there was no primary disturbance, either of temperature or pulse.

“The removal immediately by the electrodes and secondarily by sloughing of so much tissue necessitated free granulation.

“The repair which followed was unusually rapid. In fact, in this and in other cases treated in the same way, I have been impressed with the fact that proliferation is very rapid after electrolysis.

“In this case, the granulating surface healed rapidly and completely. We anticipated, independently of any recurrence of the disease, decided contraction of the cicatricial tissue.

“Electrolysis did not save the patient’s life, but it was more efficient than any plan of treatment I have seen adopted in these most distressing cases.”

*Extirpation of a mammary cancer by the knife, followed by complete destruction of the underlying tissue by electrolysis—Reappearance of the growth.*

CASE CCXIV.—Mrs. H., a married lady, aged about forty, came under our observation, through the kindness of Prof. J. L. Cabell, of the University of Virginia. The patient was suffering from cancer (scirrhus) of the left breast of about the size of an ordinary orange, and in addition one of the axillary glands was enlarged to the proportions of an ordinary hickory-nut.

She had observed while in India, eighteen years before, a small lump in the breast, but during all the years of her residence in that climate it remained stationary and never annoyed her. About eighteen months before we saw her, she left India for England, and soon after arriving in that colder and damper atmosphere the lump began to enlarge. During the process of its growth she has suffered from occasional neuralgic pains, but of no great severity.

On June 12, 19, and 28, 1873, we operated by the ordinary method of electrolysis, on each occasion introducing three needles. These efforts merely resulted in a softer condition of the tumor, with possibly some slight diminution in size, and we determined to extirpate the growth, and to destroy the surrounding tissue by the undermining electrolytic process. The patient went to her home, and in October she returned and submitted to the radical operation. Instead, however, of taking away the tumor by the process proposed, we secured the services of Dr. A. B. Crosby, who, on the eighth day, after the patient had been thoroughly etherized by Dr. N. B. Emerson, quickly removed both the breast and the enlarged gland of the axilla.

We had at hand an appliance consisting of some twenty points, projecting from a metal plate an inch and a half long, by an inch in width.

This contrivance, which we call a harrow electrode, was placed on a portion of the surface of the wound, and the operation was continued.

The needles penetrated somewhat into the exposed tissues, and the electrolytic process, which was at once begun, gave evidence of its usual activity. Hydrogen was developed in abundance, and the tissues changed in color and consistency, and rapid and complete destruction followed to a considerable depth. By this method the whole of the freely exposed surface was worked over and destroyed, and those portions that were more or less hidden were treated by two or three ordinary electrolytic needles. It was necessary to observe some caution in the regulation of the strength of the current and the position of the poles, for when the current was increased above a certain point, or, through the position of the poles, affected too directly the pneumogastric nerve, the heart's action became most markedly lowered both in frequency and force. On modifying the influence of the current, however, the circulation became as strong as usual—for a moment, indeed, there was an increased vigor in the reaction. The suppuration, which was quite profuse for a time, was followed by a healthy granulating surface, and in ten days the patient was sufficiently recovered to return to Virginia, where the healing process progressed favorably throughout.

Some six months subsequently the growth began to reappear, and will undoubtedly destroy the patient.

The above history is of interest, simply as an illustration of the special method of treatment employed. The case was of many years' standing—for two years the growth had been constantly enlarging, in-

volving the axillary glands—hence it cannot by any means be regarded as a test case. Of the two methods of treating scirrhus, viz., the removal of the growth by the electrolytic process alone, without the use of the knife, or—as in the case just related—extirpation by the knife, with the subsequent employment of electrolysis for the purpose of destroying the reproductive power of the disease—the latter seems, at least to one of the authors of this work, decidedly preferable.

By this method, although two distinct operations are performed, less time is consumed in the operation, and it is possible more effectually, and to a greater depth, to destroy the underlying tissue.

*Relief of the pain of cancer by galvanization.*—So long as we are able to do so little towards the radical cure of the worst forms of cancer, it can never be amiss to dwell upon any means that will even for a time relieve the awful agony that so frequently attends it.

It is not sufficiently understood what a magic influence an intelligently directed application of the constant current exercises, as a rule, over the throbbing pains of scirrhus, especially of the female breast. The woman at Bellevue, we referred to in Case CCIX., p. 714, had suffered most severely for many weeks. After the first introduction of the needles every vestige of pain left her, and during the two weeks that she was under observation, before leaving the hospital, she was entirely comfortable. A number of similar cases might be recorded, but we will offer only the following, which is perhaps of more interest than the majority :

*An immense ulcerating scirrhus of the breast attended by the most excruciating and constant agony—No relief follows the use of the galvano-cautery or electrolysis, but by external galvanization the pain is kept almost entirely in abeyance for months.*

CASE CCXV.—In February, 1873, Mrs. —, a patient of Dr. Everett Herrick, came to us, seeking relief from an immense ulcerating cancer of the breast. The tumor had been removed more than a year previously by Dr. W. H. Van Buren, but the wound did not entirely heal, and, a few months subsequently, the ulcerative process began, and steadily progressed. For many months the pain from which she suffered had been of unusual severity.

By the advice of her physicians, above-named, she was submitted to localized galvanization of the sound portions surrounding the ulcerating part, and by frequent applications the intense pains were for nearly four months held in almost complete abeyance. At times, however, her sufferings were most intense, and words fail to express the instantaneous and absolute relief that invariably followed the treatment. We would occasionally find her in the morning suffering most acutely. An application would dissipate the pains, and for twenty-four hours frequently, and sometimes for forty-eight, she would move about and rest in perfect comfort. In the latter part



of May it was observed that the current did not afford the same relief as formerly. The character of her sufferings had, however, changed. In the place of the sharp, shooting pains simulating neuralgia, the distress consisted in a constant burning and itching, which annoyed her more or less until her death some few months subsequently. It must be remarked that her later sufferings were not to be compared with those which the current so effectually allayed.

Was the change in the character of her pains the result of the galvanization, or is it probable that, if left to nature, the characteristic neuralgic pains would in the same way have been replaced by the less distressing symptoms of itching and burning?

It is impossible to say, but it seems reasonable to attribute the changed action to the influence of treatment. It is proper to say that, during the course of treatment, we operated in the presence of Drs. Van Buren and Herrick, by both the galvanocautery and electrolysis, with the vain hope of modifying in some degree the profuse and offensive discharge and checking the rapidity of the ulcerative process. This case was alone sufficient to teach the necessity of care in the application of electricity, and to confirm the statement that it is not so much electricity that relieves and cures as the method of using it. An application too prolonged, or with a current of too great tension, would not only fail to relieve, but on the contrary decidedly aggravate the distress. The cathode, applied to the seat of pain, did not relieve as did the anode.

The pain was for some time overcome by simple localized galvanization, but during the last weeks of treatment the applications were effectual only when the electrodes were separated as far as possible.

*Adenitis.*—Enlarged glands of the neck or groin may be treated by external faradization with strong currents, interrupted so as to break up the glands, as recommended by Meyer, or by external galvanization, or by electrolysis.

The prognosis is very capricious. In some cases the enlargements diminish quite rapidly, and entirely disappear; in other cases they are as obstinate as scirrhous of the breast. In one case referred to us by Dr. C. L. Mitchell, an enlarged parotid gland was treated at first by external faradization and galvanization with the effect of hastening suppuration. After the tumor was opened the inner portions were treated through the opening by mild electrolysis, and the tumor speedily disappeared.

## CHAPTER V.

### ANEURISMS AND VARICOSE VEINS.

IN the treatment of aneurism the great end sought is coagulation. A knowledge of the differential action of the poles in producing coagulation is essential to an intelligent use of electricity in treating aneurism. Coagulation takes place at both poles of the galvanic current; that at the positive pole being small, black, and hard; and that at the negative being larger, softer, and of a yellowish color.

Aneurisms may be treated, with greater or less success, according to their size and position, the condition of their walls, and general health of the patient, by either of the poles, or by both combined.

The best method for the majority of cases, certainly for aneurisms of any considerable size, is to use both poles, and a large number of needles that are insulated, so that the current will not act on the walls of the aneurism. In the treatment of aneurism, especially, careful insulation is needed. The advantage of using both poles is twofold.

*First.*—A double clot is formed, one at the positive and the other at the negative pole. Although the negative clot is soft and yielding, still, in combination with the positive clot, it is of decided service in closing the aneurism; and, so far as we can ascertain, there is no evidence that embolism is ever caused thereby.

*Secondly.* The resistance is greatly reduced by placing needles connected with both poles in the sac, so that the electrolytic action is very much more effective than when one pole is placed on the surface of the body. The blood is the portion of the body that best conducts electricity; and when both poles are inside of the sac, and near to each other, as of course they must be, a mild current will cause vigorous electrolysis. On the other hand, if one pole be applied by a wet sponge to some indifferent point on the surface, a strong current is needed to produce a clot, and a long operation; and, unless the sponge on the surface is occasionally moved, it would cause great pain; and if the patient is under an anæsthetic, a blister may be caused. As the negative pole is more painful than the positive, when the positive alone

is in the aneurism, the negative on the surface may be very uncomfortable, even with a feeble current. We are aware that tolerably good results have been secured in many cases of aneurism, and especially by the English surgeons, by the positive pole alone ; but we suspect that better results might have been obtained if both poles had been inserted into the sac. At all events the use of both poles should be thoroughly tested.

In the electrolytic treatment of aneurisms, as in so many other electrical applications, it is an advantage to have a rheostat, so as gradually to let the current on or off without shock.

*Statistics of Aneurism treated by Electricity.*—The published statistics of aneurism treated by electricity are of little or no value, and for two reasons : 1. They represent experiments made, in a large percentage of the cases, by those who are but little familiar with Electro-Physics, or Electro-Physiology. Quite frequently the poles have been confounded, so that it is impossible to tell whether the positive or negative is used, and from many of the accounts, it is impossible to tell even approximately the strength of current employed.

2. The statistics are derived, in part, at least, from cases that are reported too early. The temporary relief that results from the coagulum formed in the aneurism by the chemical action of the current has been interpreted as indicating a perfect recovery.

Some of the cases hastily reported as cured probably died soon after, if not before, the account of their recovery was fully in print.

For these reasons we omit all the statistics that have appeared on this subject ; preferring the general average opinion, so far as it can be obtained, of those surgeons and electro-therapeutists who are best qualified to speak on this subject.

Our general conclusion, derived from many experiments on animals, from actual experience, and from a comparison of the various observations that have been made on the subject, is that for those varieties of aneurism—such as the thoracic, abdominal, and so forth—that cannot well be treated by the old methods, and in some cases for those that are accessible to other treatment, galvano-puncture, rightly performed, may be of great service in relieving the accompanying symptoms, in prolonging life, and may now and then achieve a radical cure.

The following case is condensed from the published account of **Dr. Keyes**,\* in co-operation with whom the operations were made :

\* New York Medical Journal, December, 1871.

*Aneurism of abdominal aorta treated by galvano-puncture—Relief of symptoms—Death and post-mortem.*

CASE CCXVI.—A widow, 42 years of age, had been afflicted for many months with a "swelling in her stomach," that all the surgeons regard as aneurism of the superior mesenteric, or of the aorta. The patient was in Charity Hospital. There was pain in the epigastric region, which was aggravated by movement. The tumor, which was about the size of the fist, was situated to the left of the median line, and extended a little below the umbilicus. A thrill could be detected at the upper part of the tumor, but not at the lower.

The patient was gradually failing.

The only case of treatment of abdominal aneurism by galvano-puncture recorded at that time was that of an Italian nobleman, a patient of Dr. Felice Dell' Acquia.\* In this case the patient died directly after the operation from rupture of the aneurismal sac, caused by violent muscular contractions while under the influence of chloroform. Three needles, connected with a voltaic pile, were used for forty minutes. Only a small coagulum was formed.

March 30th, 1871. A hollow steel needle was cautiously introduced, and connected with the positive pole, while the negative pole was applied externally by means of a sponge. Only from eight to twelve zinc-carbon cells were used. Drs. Wood, Sayre, and Mason made digital compression to the aorta below the umbilicus. The needle adhered and came out with some difficulty, but no blood followed. *The bruit seemed fainter than before the operation.* No unpleasant result followed except some pain that was produced by the compression, and exhaustion that was produced by the etherization.

April 6th. Operated as before, but with two positive needles, insulated to within a short distance of the points. One of the needles was hollow, and was introduced until the blood flowed through it. From twelve to sixteen freshly charged zinc-carbon cells were used for twenty-five minutes. The solid needle was more acted on than the hollow needle, being nearly destroyed at the non-insulated extremity. No compression was used. *Before the operation two murmurs were heard; after the operation, but one.* Patient suffered less than after the other operation. Some irritative fever appeared. Evidence of solidification of the tumor.

May 4th. Six positive needles were introduced; three connected with a zinc-carbon battery of seventeen cells with larger plates. The current was passed for forty-one minutes. There was no compression of the aorta.

June 22d. Patient greatly improved; gets up and dresses herself. Tumor quite hard.

Used two batteries as in previous operation. Eleven needles were used, and the current was passed sixty-five minutes. There was less irritation after this than after the other operations. The tumor became harder, but not smaller, and a murmur could be heard only with great difficulty.

In spite of the improvement in the condition of the tumor the patient grew weaker and weaker, and died of exhaustion, July 18, 1871.

*Post-mortem* examination by Dr. Drake revealed the surprising fact that the patient had *three aneurisms*: one of the arteria innominata about twice the size of an English walnut; one of the aorta opposite the sixth and seventh dorsal vertebræ, about eleven

\* Gazzetta Medica Italiana, Lombardia, No. 28, 1870, p. 217.

inches in circumference; and the one operated on, which was found to arise from the anterior wall of the aorta at the origin of the superior mesenteric. This aneurism was about twelve and a half inches in circumference. In all three of the aneurisms organized light-colored clots were found. The one operated on was less solid than the others. There was, indeed, no evidence that the galvano-puncture had produced any permanent clot. It is possible, however, that it caused a temporary clot that was wasted away by the current of blood. There is no question that the tumor became *more solid after the operation, and that this solidification was attended with diminution of the nausea and pain.*

Luigi Ciniselli\* has written a monograph on *aneurisms of the thoracic aorta* treated by galvano-puncture. He speaks of twenty-three cases. Of these six recovered, sixteen died, and in one case the result is not known. Of the six reported as cured, one relapsed in three months, another in seventeen months, another in four months, but was again operated on, and after eight months there had been no relapse. Of the remaining three cases one had not relapsed up to nine and a half months, another had not relapsed at eight and a half months, and the last remained well at four and a half months.

Eyre has reported a case of aneurism of the left external iliac artery by *farado*-puncture. Symptoms of inflammation appeared, but after seventeen days the tumor was firmer, and evinced less pulsation. The faradic current, however, has nothing to commend it for the treatment of aneurism.

Ciniselli successfully treated an aneurism of the ascending aorta in a patient forty-six years of age, by a galvano-puncture. Three needles, connected with a voltaic pile of thirty pairs, were inserted in the third intercostal space where the tumor was prominent and the pulsation strong. The operation lasted forty minutes. After the operation the skin over the tumor was red. For three weeks the patient kept his bed and took digitalis. Forty-three days after the operation he left the hospital.

Fifty-eight days after the operation only a slight prominence remained, and no pulsations could be seen. Seventy-eight days after the operation the patient resumed his occupation, which was that of a coachman.

*Varicose Veins.*—Varicose veins were treated by galvano-puncture after the manner of aneurisms many years ago.

Bertani and Milani experimented in the treatment of varicose veins by galvano-puncture as far back as 1847. These observers applied a bandage or tourniquet to the limb to diminish the blood supply before operating.

\* *Sugli aneurismi dell' aorta toracica finora trattati colla elettro-puntura.* Miliano, 1870. Quoted in Dr. Keyes's paper on Practical Electro-Therapeutics, N. Y. Medical Journal, December, 1871.

Baumgarten and Wertheimer successfully treated a severe case of varicose veins of the upper extremity up to the acromion, whence the evil seemed to spread over the trunk. The patient was a young girl. The limb had doubled in size.

“ Baumgarten and Wertheimer introduced in three sittings, at an interval of two or three days each time, about ten needles into the most extended veins, placing a conductor connected with the negative pole in the hand of the patient, at the same time connecting all the needles with the positive pole. The operation caused but little pain. After a few minutes the needles were removed, when, in place of the dilated veins, full resistant cords were felt, a sure sign of complete coagulation. After a month, the greater portion of the veins were obliterated, and the volume of the limb considerably reduced; only then those veins, heretofore of normal size, began to dilate a little, which circumstance can exercise no influence on our opinion of this *modus operandi*.” \*

For the treatment of varicose veins the positive pole would possibly be better than the negative or than both together, and for the reasons above given. The space within the enlarged vein is comparatively small, and the small clot made by the positive pole ought to be sufficient to obstruct the flow of blood. The positive clot would have the advantage of firmness, and embolism would be less likely to follow than after the use of the negative pole.

\* Meyer, *op. cit.*, p. 471.

## CHAPTER VI.

### STRICTURES.

*Strictures of the Urethra.*—Electrolysis for strictures was first used by Crussel. The same treatment was subsequently employed by Willebrand and Wertheimer.

The method of Willebrand was to introduce to the stricture a metallic sound, insulated up to the tip, and to connect this with the negative pole, while the positive was held in the hand of the patient. The application was continued for ten or twenty minutes, and the cure was accomplished in eight or ten days.

The subject was afterwards studied, though not with special success, by Jaksch and Leroy d'Etiolles.

The first important and successful results in the electrolytic treatment of strictures of the urethra were obtained by Mallez and Tripier, in 1867.\*

Their method of treatment was to introduce an insulated sound with a metallic extremity to the seat of the stricture, connecting it with the negative pole, while the positive was applied to the inner side of the thigh by a moistened sponge electrode.

At the commencement of the operation the patient feels a pricking sensation. This sensation becomes less and less marked. The metallic extremity is then passed along until all parts of the stricture are affected. After the operation a catheter can be introduced without difficulty.

The operation lasts about five minutes; from one to five applications are necessary. In the majority of the thirty-one cases treated by Mallez and Tripier, as they claim, one application was sufficient.

The diameter of the urethra seems to increase slightly for a few days succeeding the operation, and in some cases an eschar was thrown off in a few days after the operation.

\* De la Guérison durable des Rétrécissements de l'Urèthre, par la Galvano-Caustique Chimique, Paris, 1867. The term "*chemical galvano-cautery*," used by these authors, is synonymous with *electrolysis*.

Experiments made in Charity Hospital by Drs. Keyes and Beard,\* and the experience of Dr. Rockwell in private practice, do not entirely confirm the results given by Mallez and Tripier, although substantially the same method was used. The operation was found to be painful oftentimes, and the results not always satisfactory, as the following record, which is a fair sample, will show.

CASE CCXVII.—F., aged forty, general health excellent. First gonorrhœa at twenty-second, second at thirty-eighth year of age. Stream became gradually reduced until Jan. 11, 1871, at which time he had complete retention for fifteen hours, relieved by hot baths. The patient entered the hospital, and was treated by dilatation.

February 6th.—Examination detects the following strictures (orifice admits 14 easily): At orifice, stricture (linear) arresting No. 14 soft bulbous sound. At two and a half inches, stricture (linear) arresting No. 12. At five inches, stricture, one-third inch long, arresting No. 9. Current from ten cells was passed through second stricture for five minutes. A good deal of pain complained of. Current from ten cells was passed through lower stricture for ten minutes.

No. 12 bulbous sound passed easily into the bladder after the operation.

March 4th.—No slough has been passed. No. 9 steel sound is grasped by stricture.

March 15th.—(Using my own instrument with steel bulb 15½ .)

Stricture at the orifice; fifteen cells; five minutes; bulb passed. Stricture at two and a half inches; sixteen cells; ten minutes; bulb passed. Stricture at five inches; sixteen cells; thirteen minutes; bulb passed. A little blood was lost at this operation, and a good deal of pain was felt afterwards. No slough was passed. The orifice swelled and became hard and inflamed. Patient refused to follow up the treatment or to be examined further.

Dr. Robert Newman reports far more satisfactory results in the treatment of strictures of the urethra.†

The leading and distinctive features of his method are these: 1. The use of very *mild* galvanic currents, just perceptible to the patient, and from three to five minutes in duration. Like other observers he uses the negative pole. The instrument should be held loosely against the obstruction, and no pressure should be used, and no force whatever. 2. Long intervals, from two to four weeks, between the applications.

Dr. Newman insists on a careful preliminary diagnosis of the nature and exact seat of the stricture. He operates with bougies provided with metal bulbs of various sizes. Unless the stricture is too firm or fibrous he uses a bougie which is three or four times larger than the stricture. After he has ascertained by measurement the exact locality

\* From article of Dr. Keyes in the N. Y. Medical Journal, December, 1871.

† Archives of Electrology and Neurology, May, 1874, p. 18.



of the stricture, he pushes a small india-rubber ring over the bougie, at such a distance from the end that when the ring reaches the meatus he will know that the bulb is in contact with the stricture, and then he is assured that the electricity acts only on the stricture.

Dr. Newman regards a patient as cured when a No. 12 English sound can be passed without trouble. He claims to have treated in this way over thirty patients, and that his results have been uniformly good, and for the reason in part that he has selected his cases. He does not claim that all strictures can be treated successfully in this way, but states that some of his cases were bad and complicated.\*

*Two strictures—Chancroid—Failure of dilatation—Success with electrolysis.*

R. A., hotel-keeper, came under treatment in March, 1872. Had been treated in the country for stricture by dilatation, with no success. Found a chancroid in the urethra, which was treated first. The two strictures were found situated at one and a quarter and four and a half inches from meatus respectively.

*March 22.* Electrolysis was used with a bougie No. 10, with a metal bulb as negative; positive electrode in the palm of the hand. Ten cells of the galvanic battery were used for nine minutes, and the bougie passed slowly through the strictures into the bladder.

*April 14.* The operation was repeated with a bougie No. 12. The patient has been heard from recently, and has not had a relapse.

*One stricture, spermatorrhœa, impotence, melancholia.*

*March, 1872.*—R. S., a merchant of Philadelphia, came to my office in an advanced stage of hypochondriasis, complaining of general malaise, spermatorrhœa, impotence, small stream of water, pain in the urethra, etc. A steel sound No. 12 entered the urethra easily, but was arrested at seven inches. Sounds of

\* Dr. Newman gives the following bibliography of the subject :

Mallez et Tripier, "Traitement des Rétrécissements Urétraux par la Galvano-Caustique Chimique Négative, Compte Rendu de l'Acad. des Sciences. Bulletin Thérapeutique, Mai 30. Med. 58.

Mallez et Tripier, "De la Guérison durable des Rétrécissements de l'Urèthre par la Galvano-Caustique Chimique."

Althaus, in Goeschen's "Deutsche Klinik," No. 34-36, "Heilung der Hamnröhren-Stricturen durch die Electrolyse."

Keyes, "Electrolytic Treatment of Stricture of the Urethra." New York Medical Journal, December, 1871.

Bautisto Campos: "De la Galvano-Caustique Chimique comme moyen du Traitement des Rétrécissement de l'Urèthre." Paris, 1871.

Dutrieux, "De la Galvano-Caustique Chimique dans le Traitement des Rétrécissements Organique de l'Urèthre." Press. Med. Belge, No. 25, 1872.

Mallez et Tripier, London Lancet, October, 1871.

"Multiple Strictures of the Urethra treated by Electrolysis," by T. F. Frank, M.D., Medical Record, February 2d, 1874, page 62.

smaller size were all arrested likewise at the same place. There is no doubt that a stricture exists, and at last a sound No. 7 passed it with difficulty. The trouble must exist either at the junction of the membranous and prostatic portion, or in the latter only. Galvanism was used with ten cells. Bougie No. 10, with the usual metallic end as negative into the urethra, met the same obstruction at seven inches. The positive pole was a nickel bulb, and grasped firmly with the closed hand. After five minutes of electrolytic current, the bougie passed the stricture slowly and slipped into the bladder. The withdrawal of the bougie was followed by a thick, gleety discharge. It seems that this matter had accumulated behind the stricture, irritated the prostatic portion and the ducts, and thereby was accessory to creating a spermatorrhœa. On passing water, shreds came along of a thick white mass, which were the product of electrolysis. The operation has not caused any pain, and the patient travelled home without unpleasant feeling.

*April 16.* On examination with a sound No. 10, found the stricture at the exact place; the sound passed the stricture after persistent and patient efforts.

Then the galvanism was used as before, with a bougie No. 12 as negative, and with the same result.

*May 9.* In Philadelphia, a sound No. 12 could be easily passed into the bladder, which proves that the stricture is cured. The patient has been kept under observation for two years, and has been seen only two weeks since. He is perfectly well; has married since, and is the father of a healthy child.

**CASE CCXVIII.**—J. A., aged forty. Two attacks of gonorrhœa in 1856 and 1869. Orifice admits 18. Double linear stricture in first half-inch, admitting 13 bulbous sound. From one and a quarter to six inches from the meatus the whole urethra is stiff and rigid.

It grasps No. 13 steel sound throughout. At six inches a short stricture exists, through which No. 11 passes into the bladder.

*Feb. 21, 1871.* Steel bulb 15½; six to sixteen cells, gradually increasing. First stricture passed in one and a quarter minutes.

In half a minute more, lowest stricture was reached. In half a minute lowest stricture was passed. Some blood followed.

*March 4.* Steel sound No. 15 passed into bladder. No. 16 was grasped and would not go. Patient left the hospital.

**CASE CCXIX.**—S. F. P., aged sixty. Gonorrhœa at eighteen, another at twenty. In 1836 he entered a hospital to be treated for stricture, and was gradually dilated to 12. In 1860 forcible dilatation was practised under chloroform. He neglected to pass instruments for himself, and had to be treated again in 1864, this time by gradual dilatation. Since then, he passes No. 3 soft bougie "every time he makes water," but he does not pass it into the bladder. On examination, I find stricture commencing at two inches from meatus, and continuing indefinitely as far as could be ascertained. Only a No. 3 bougie could be passed into the bladder. Urethra feels (outside) like a fibrous cord.

*March 16.* Steel bulb 6; sixteen cells; twenty minutes; no progress; battery seemed very weak.

*Spasmodic Stricture.*—This condition may be relieved by the faradic

current, which by its mechanical action probably has the effect to relax the parts.

Dr. Chadsey\* reports a case of retention of urine, of two days' standing, in 1844, caused by hard work and exposure to cold, that he treated successfully by faradization. The stricture was about two-thirds of the distance from the penis to the bladder. No kind of catheter could pass. The positive pole of a faradic apparatus was applied against the stricture for twenty minutes by means of a knitting-needle in a gum elastic catheter. The retention was completely relieved.

Dr. Chadsey states that he has met with partial success in other similar cases.

In this case the result was probably due, in the main, to the mechanical effects of the current, and not to any electrolytic action.

*Stricture of the Œsophagus.*—This terrible condition might very appropriately be treated by electrolysis. Althaus suggests that the œsophageal electrode should be applied to the seat of the stricture and connected with a negative pole, while the positive is applied to the neck or back. From fifteen to thirty cells would probably be required. Dr. Frank informs us that he treated successfully a case of spasmodic stricture of the œsophagus, by the galvanic current, applied by means of an œsophageal electrode.

\* New York Medical Journal, February, 1869, pp. 574, 575.

## CHAPTER VII.

### ULCERS, FISTULÆ, AND SINUSES.

*Ulcers—Bed-sores.*—The earliest attempts to treat ulcers by electricity were made by Crussel, in 1847.

The same treatment has been used in syphilitic ulcers by Kyber, of Cronstadt, Rosenberger, of St. Petersburg, and in the majority of their reported cases with success.

Ulcers may be treated with both currents by means of metallic disks or plates covered with soft sponge. Galvanization serves to cure in such cases partly by its *electrolytic* effects. One electrode may be applied to the ulcer, and the other to the *nearest large nerve-branch or plexus, or to the sympathetic or spinal cord*. The applications should not be excessively painful. In some cases decided results may follow a single application of electricity to an ulcerated surface. In a case of an ulcer in the leg of a girl eight years of age, one faradization with a current of moderate strength so improved the nutrition of the parts that healing at once commenced, and in a short time entire recovery took place without any further treatment. Ulcers may also be cauterized by the galvano-cautery.

In the treatment of ulcers, and indeed of many conditions, it is a convenience to have one electrode kept in a fixed position without the aid of the physician or of an assistant. For this purpose the adjustable electrodes, provided with a rubber belt which can be passed around the limbs or body, are convenient.

Ulcers may also be treated by prolonged applications with the so-called "body batteries." A disk of zinc connected by a wire with a disk of silver. Either the zinc or the silver disk may be applied over the ulcer, and the circuit completed by one disk on an indifferent point, or in case there are two ulcers, one may be covered with the silver disk, and the other with the zinc disk. These disks may be kept in position and worn all the time, or only at night.

Garrett's electric disk may also be used for the same purpose.

The results of these prolonged applications are most excellent, es-

pecially in bed-sores. We have known them to fail, however, in very bad cases, and notably when great debility existed.

*Indolent ulcer of the arm ; recovery under local galvanization.*

CASE CCXX.—Mary H., aged forty, while moving, May 1, 1871, fell and injured the arm immediately above the external condyle. The pain was excessive and continued to distress her for several weeks, when a small ulcer made its appearance and enlarged until it was two inches in diameter.

The patient applied for treatment, July 18. The ulcer was covered with a dark-colored scab three-fourths of an inch, partly lifted from its resting-place by exuberant and unhealthy granulations.

The scab was removed, and a wet cloth in connection with the positive pole was applied to the diseased part, while the negative was placed on an indifferent but approximate part. The galvanic current was used. She suffered no more pain after the second *séance*, and as the applications were repeated the ulcer rapidly healed, until August 30, when the part was covered by sound, healthy skin.

*Syphilitic ulcer ; recovery follows three operations by electrolysis.*

CASE CCXXI.—Catherine McK., aged forty, suffered three years since from a number of syphilitic tubercles and ulcers about her hips, thighs, and vulva. They persisted along time and gave her much annoyance, but finally healed, with the exception of one on the inside of the thigh. It was elevated nearly one-half an inch above the surrounding surface, was excessively painful, and discharged an offensive secretion. A needle connected with the positive pole was passed through the base of the elevation, and a current of moderate tension allowed to pass for a few moments. This application dissipated all pain, and after the third *séance*, given several weeks after the first, soon healed, and the patient was discharged from the Dispensary.

*Anal Fistula of long standing treated by galvanization with both poles—Relief of pain.*

CASE CCXXII.—A case of fistulæ, at and near the anus in a shoemaker, was brought to us by Dr. Russell, of Brooklyn. The patient had a fistula with four openings—one in the rump and the others at the border of the anus. The origin of the difficulty was local injury. The patient had once been operated on with the knife without permanent relief. Examination had made it pretty clear that necrosed bone was the cause of the fistula, and kept up the constant discharge.

We first electrolyzed away with the long cutting needles the painful protuberances at the orifice, near the anus. The removal of these caused great relief, and enabled the patient to sit down and to resume his occupation. We then placed long, polished steel conductors into the opening in the rump, connecting them with the negative or positive pole, using the positive when the hemorrhage was greatest. The conductors were introduced up to the bone. *Strong currents were borne*, and great relief obtained of the pain and uneasiness, but no permanent cure.

*Galvano-Ozonization.*—This is a term employed by Dr. A. Murray, of New York, to designate the combined action of ozone and the galvanic current in the treatment of ulcers. He claims that his experi-

ments show that ozone is generated at the positive pole when the galvanic current is applied to an ulcer, and that the ozone thus generated has a curative effect on the ulcer, and aids the other action of the current.

For this reason he regards the positive pole superior to the negative in the galvanic treatment of ulcers, fistulæ, and so forth.

## CHAPTER VIII.

### MISCELLANEOUS SURGICAL DISEASES.

*Stumps after amputation* that are slow to heal have been successfully treated by electricity, like ordinary ulcers, by Dr. Geo. K. Smith and by Dr. Snively, of Brooklyn.

*Hæmatocele.*—Hæmatocele of the pelvis or pudenda, or of other portions of the body, may be treated electrolytically, like erectile tumors, and by ordinary faradization.

*Gangrene.*—Gangrene may be treated electrically in various ways, but especially by electrolysis and galvano-cautery.

*Carbuncles and Furuncles.*—Dr. Rockwell demonstrated long ago that faradization was capable of hastening suppuration, and we have frequently utilized this fact in the treatment, not only of carbuncles and furuncles, but of various other forms of abscesses. Dr. Sass informs us that a number of years since he used this treatment in two instances with good effect.

*Burns.*—Burns in a subacute stage might not unlikely be helped toward recovery by faradization or galvanization.

*Frost-bite (Chilblains).*—In the first edition of this work we stated that we were not aware that any attempts have been made to treat chilblains by electricity, but that it certainly would not be irrational to try the power of galvanization in this disease. Successful results have been recently reported by various observers. Chilblains are to be treated like ulcers.

*Synovitis.*—In effusions of an acute and very sensitive character, electricity is usually not indicated, but in the subacute and chronic forms it is of great efficacy. The treatment should be directed by the cause and stage of the disease, and by the results of trial in each case.

The treatment of those cases that depend on rheumatism, or hysteria, should be constitutional as well as local. In some cases general faradization, with special attention to the affected joint, is sufficient; in others the general treatment is sensibly aided by galvanization or faradization of the joint.

Whether the galvanic or faradic current is to be preferred for local applications can only be determined by the results of trial. Our custom is to begin with the faradic current, and to use it so long as benefit results, and then to change to the galvanic. It should be borne in mind that the greater chemical effects of the galvanic current are in these cases frequently more than counterbalanced by the powerful mechanical action of the faradic. Stable increasing currents are to be preferred.

This is one of the conditions in which localized galvano-faradization (see p. 266) may be tried. The electrical treatment of effusions of the joints is much aided by using the hands as an electrode, with gentle but firm manipulation. There is no question that under the influence of "rubbing" have been wrought many important cures in these affections.

Electrolysis has been successfully employed in effusions. It may be resorted to in all obstinate cases.

*Synovitis of the knee, complicated with hemiplegia—Recovery under faradization.*

CASE CCXXIII.—Mr. Geo. L., aged 35, stated that about the 1st of July, 1866, he was sunstruck; and between the 20th of the same month and the 15th of August, he suffered from three strokes of hemiplegia, resulting finally in total blindness. His sight gradually returned, but by degrees his shoulders became lame and stiff, so that he could with difficulty use them. This state of things continued until about the middle of September, when both knees and ankles commenced to enlarge. In November, when the patient applied to us for treatment, we found him suffering from severe sub-acute synovitis. Both knees were enormously swollen, the fluid having accumulated to such an extent that the patellæ projected forward more than an inch. Four applications of the faradic current were given, one every day, but with no marked effect, except that the lameness of the shoulders and ankles was much relieved.

He then left the city and was absent one week. On his return the improvement was found to be very great. The accumulation of fluid in the knees had almost entirely disappeared, and the swelling was reduced in proportion. At first, the strongest current from Kidder's apparatus made no impression, when applied down the spine. The legs were but little sensitive to the electric stream, and the feet and toes, which are generally very readily affected, were remarkably torpid. The applications were continued on Dec. 3d, 4th, 5th, 7th, and 9th, effectually removing this want of sensation, and completely dissipating the remaining swelling and tenderness of the knees.

*Hydrocele.*—Electro-puncture was first tried for hydrocele by Schuster, in 1839.

The method is to introduce the needle into the tumor at opposite sides, and so deep that the points nearly approach each other. The needles are then attached to from three to six elements of a galvanic battery. The application should be made for five or ten minutes. One,



two, or three applications usually suffice to complete a cure. The same treatment has been successfully employed by many others.

Successful results from the faradic current have been reported by Burdel, Deletanche, Lehmann, and Thevisen. The galvanic is undoubtedly the current to be employed in such cases.

Hydrocele, in short, should be treated electrically like cystic tumors. The great end to be accomplished is not the withdrawing of the fluid, which can be done with the ordinary trocar, but the stimulation of the membrane of the sac, so that absorption shall take place and the fluid not again collect. Many of the failures that have occurred in the treatment of hydrocele have been due to a misapprehension of this fact. Dr. Frank has combined the use of galvano-cautery with electrolysis in the treatment of hydrocele. In some cases there will be a return of the disease even after electrolysis.

*Sprains (sprains).*—Sprains of joints of all kinds may be treated by electricity; faradization and galvanization of the affected part with a mild, stable, or gently labile current are indicated. We have in this way treated all stages of sprains—acute, subacute, and chronic—and almost uniformly, thus far, with beneficial or curative results. We have not been able to decide which current is preferable.

Sprains in the acute stage, or just passing into the subacute stage, should be treated by very mild currents and by short applications.

In such cases no electrode is so agreeable as the hand of the operator gently passed over the painful part.

We have treated a number of cases of sprains of the wrist in patients who are engaged in manual employments. In such conditions the localized application of the faradic current alone rapidly brings on the recovery.

*Strains of muscles with rupture of fibres,* so far as our limited observation goes, do not yield to electrical treatment. In the few cases where we have perseveringly used faradization and galvanization we have not been able to see that the slow improvement was in any degree hastened.

*Lameness and swelling caused by a sprain—Relieved by local faradization.*

CASE CCXXIV.—The power of the faradic current to allay irritation and relieve lameness, in cases of sprains or injuries, was well illustrated in the case of a Mrs. B., directed to us by Dr. Kissam. Her foot was heavily pressed upon by the rocker of a chair, and caused such ecchymosis, pain, swelling, and lameness, that for two months she was unable to walk more than from her house to her carriage. The faradic current, applied over and around the foot a number of times, relieved most decidedly the

swelling and lameness, and enabled the patient, in a few weeks, to exercise in walking without serious difficulty.

*Spondylitis (Pott's Disease).*—Spondylitis is a term that is applied to inflammation of the vertebræ. Among its symptoms are at first changes in shape of the spinal column, obstinate gastralgia, or neuralgic pains in the breast and various parts of the body, and subsequently projection of the diseased vertebræ, deformity of the spine, peculiar attitude and paralysis,\* sensitiveness of certain vertebræ, and spontaneous pains in the spine.†

The form in which it appears is in the cervical and upper dorsal vertebræ, with the symptoms of neuralgia in the arm, or neck, or lower limbs. Some cases of torticollis, and even of chorea, may depend on disease of the vertebra. Other symptoms are paralysis, atrophy, or contraction of certain muscles. In many cases of inflammation of the vertebra the nature of the disease is not suspected, because the changes in the form of the spinal column and the immobility of the vertebra only appear after the morbid process had made considerable advance.

In making the diagnosis it should be considered that the appearances of the spine, which are usually regarded as evidences of spondylitis, may arise from paralysis, or atrophy of the muscles, with contractions of the antagonists.

The treatment consists in galvanization of the affected vertebræ, the positive pole being placed over the seat of the disease, and the negative at some point above or below. The results are sometimes beneficial.

*Spinal Curvature.*—Lateral curvature of the spine, depending on relaxation of the muscles and ligaments, and associated with general debility, is a condition for which general and localized faradization and galvanization of the sympathetic are well indicated, and in which they have wrought most important results. General faradization alone is pretty sure to be of service, both in raising the tone of the system and in permanently relieving the curvature. The electrical treatment may be used in connection with mechanical appliances.

*Pseudo-arthritis (Ununited Fracture).*—Burman obtained a good result from electrical treatment of a transverse portion of the tibia and fibula. After the lapse of a month the bones had not united. A bandage was applied and a current (whether faradic or galvanic is not

\* See paper on *Differential Diagnosis of Diseases of the Spine*, by Chas. F. Taylor, M.D.

† Benedikt, op. cit., 312.

stated) was applied for half an hour by two needles. Suppuration followed, callus was formed, and entire recovery took place.

Hall also obtained a successful result in a fracture of the thigh by the same treatment. The operation was repeated daily for two weeks.

Hahn also reports a successful result from electro-puncture in a case of fracture of the thigh. He used at first magneto-electricity, and subsequently the galvanic current. No improvement followed the use of magneto-electricity, while the galvanic current brought on inflammation in six days. The inflammation thus excited produced a union of the fracture in ten days.

We treated a case of ununited fracture of femur at the Long Island College Hospital. Insulated needles were used, and very strong currents. Inflammation was excited, and some improvement was manifest, but the bones were so far apart that it was found necessary for the surgeons to operate in the usual manner.

*Hernia.*—Delaux reports a case of incarcerated femoral hernia in a woman who refused to submit to an operation. Tumor disappeared after a few applications. The first application was directed to the hernia, and in the other applications one pole was applied to the hernia and the other in the rectum. Before electrical treatment was tried the patient was growing worse. Faradization might give tone to the weakened muscles in reducible hernia, and for this purpose we have employed it in a single instance; of the results we have not been informed.

*Morbus Coxarius (Disease of the Hip-joint).*—This condition may be treated electrically, in connection with ordinary mechanical treatment, with a twofold object of hastening the recovery of the lesion and improving the general condition. The methods of treatment that would seem to offer most hope are stable faradization or galvanization of the diseased joints, five, ten, or fifteen minutes daily, alternating with general faradization. This treatment might be used in connection with the ordinary method by extension.

*Club-Foot (Talipes).*—In club-foot it is not unfrequently a great advantage to combine faradization or galvanization of the partially paralyzed muscles with the use of mechanical appliances (see chapter on Infantile Paralysis).

*Warts.*—Warts, if they were regarded as of sufficient importance, might be removed by electrolysis of the base, or by the galvano-cautery.

*Dissolution of Calculi in the Bladder.*—The employment of the gal

vanic current to dissolve calculi was proposed by Bourier in 1801, by Morgiardini and Lando in 1803, and by Gruithuisen in 1813, but was first successfully carried out by Prévost and Dumas in 1823.

The theory of Prévost and Dumas was, the calculus could be made to crumble by the mechanical effect of the gases generated by the current. In their first experiment they placed a fusible human calculus in water, submitted it to the action of a voltaic pile of 120 elements for twelve hours. Platinum wires were placed against the calculus, on opposite sides. Fine powder soon appeared. At the end of the operation the calculus was found to have lost 12 grains in weight, the original weight having been 92 grains. It was again submitted to the current for 16 hours, at the end of which time it was reduced to very small fragments that could have easily passed the urethra.

Their second experiment was made on a fusible calculus in the bladder of a living bitch, into which warm water had been injected. The application, which lasted an hour, was repeated 12 times during six days. The calculus had become so friable that the operation was not repeated. Examination of the bitch after death showed evidence that the bladder had been injured by the operation.

In 1835, Bonnet proved that by applying platinum electrodes to the opposite sides of a calculus in a solution of nitrate of potash, electrochemical decomposition ensued, by which nitric acid appeared at one electrode and potash at the other. The effect of these two substances was to dissolve the calculus. Stones composed of phosphate will be dissolved on the acid, and those composed of uric acid or urate of ammonia on the alkaline side. Under this action, the stone, unless very hard, becomes friable and falls to pieces. These experiments were confirmed by Bence Jones, who also found that calculi of oxalate of lime could be slowly dissolved in the same way. Neither of these experimenters attempted the dissolution of calculi in the human bladder. Some experiments made by Dr. Rockwell in this line, and also by Dr. Beard, at the suggestion of Dr. Gouley, did not give very satisfactory results. The amount of decomposition of phosphatic stone was very trifling, even when strong currents were used for several hours.

*Electric Explorer or Probe.*—This apparatus (Fig. 188) indicates at once the presence of metallic bodies in gunshot wounds.

Fig. 1 represents its natural size. Fig. 2 shows one of the exploring sounds. There are generally two sounds, one stiff, the other flexible.

The trembler or needle is so arranged as to resist all shocks and fulfil the following conditions :—

1. It is very portable, and in all possible positions can be carried in the vest pocket, or in the ordinary surgical case.

2. It cannot be deranged.

3. Three senses take part in making the exploration—the hearing, the touch, and the sight.

4. It indicates with certainty the presence of a ball by the movement of the trembler, an effect which is only produced *when the circuit is closed by a metallic body*. Experience has shown that the contact of organic tissues, even with a battery of 15 elements (and probably with even a greater number), will not put the trembler in vibration.

5. The explorer indicates at the same time the depth at which the ball is situated, and in some cases also the flexible sound preserves the form of the canal through which it passes.

The battery is in a case made of hard rubber. This holds the elements, zinc and carbon, which fill only half. The other half is occupied by the exciting liquid, a solution of sulphate of mercury. When the case is reversed, or in a horizontal position, the liquid flows on to the element and a current arises; when the case is in a vertical position the metals are not touched by the liquid, and there is no current.\*

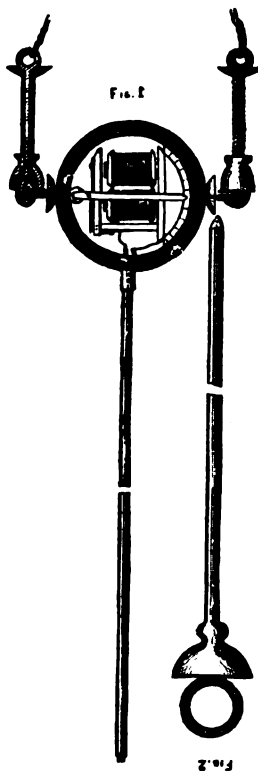

FIG 188.

Trouve's Electric Explorer.

\* The first apparatus for the electric exploration of wounds was devised by M. Favre, of Marseilles, of which the following description was given by Nélaton, in remarks to his class at the *Hôpital des Cliniques*: "Two conducting wires are placed in a sheath, or the two electrodes may be covered by an isolating substance. These wires are in communication with a battery of only one couple, and a galvanometer is fastened on one of the wires. If you introduce the end of these into a wound, the contact of the soft parts, the bones, or pus, is not sufficient to establish a current, but if the ends come in contact with a metallic body, the needle of the galvanometer will rise, this being a proof that the circuit is complete. Only one couple, however, should be used, so as to avoid the decomposition of the fluids in the wound, which would immediately give rise to a current."—(*Am. Jour. Med. Sciences*, vol. xlv., 1863, p. 218.) During the recent Franco-Prussian war an "*Electric Bullet-seeker*," that strikes a little bell when metallic connection is made, has been successfully used.

*Extraction of Foreign Bodies by the Electro-Magnet.*—Dr. Delore\* has suggested the electro-magnet as a means of extracting foreign bodies from the eye, urethra, auditory canal, etc. He states that the magnet has been used for the purpose of extracting pieces of iron and steel from the eye since the days of Fabrice de Hilden. Delore's attention was called to the subject by an attempt which he made to extract a piece of a pin from the external auditory canal. A slender magnet was prepared by M. Fasse, which could be bent at will, but it was found to be not sufficiently powerful. Then M. Fasse suggested the idea of using the electro-magnet for this purpose. With this view he constructed a small electro-magnet, composed of a stem of iron, with a bulbous extremity, and covered with several windings of insulated copper wire.

The force that is obtained is in proportion to the strength of the current used to magnetize the iron, the number of spirals, and the diameter of the magnet.

In order to ascertain how much power was necessary to extract needles from the body, a number of experiments were made.

"A needle embedded in the horny substance of the hand to the depth of three millimetres requires for its extraction a traction of 89 grammes."

"Embedded sixteen milli. deep in the heel of a cadaver requires 400 grams."

"Embedded four centimetres deep in the calf of the leg it requires 400 grams."

"If it has perforated the cornea it must have a traction of 39 grams."

The advantage claimed for this method of extracting foreign metallic bodies is that "it produces no sensation on the surface of the tissues," and also is less liable to injure them than forceps or probes.

The investigations of Dr. T. R. Pooley, of New York, lead him to the following conclusions: 1. That a steel or iron body in the eye may be detected by a suspended magnet when the body lies near its surface. 2. The presence and position of such a foreign body may most surely be found by making it a magnet by induction, and then testing for it by a minute suspended magnet. 3. The intensity of deflection of the needle is proportionate to the depth of the body. 4. Changes of deflection of the needle indicate changes of position in the foreign body.

An interesting case is reported by Hardy.† Forty-eight hours after the injury a small, narrow strip of steel was seen resting on the anterior

\* Translated from *Lyon Medical*, in *N. Y. Medical Gazette*, Aug. 20, 1870.

† *Medical Times and Gazette*, April 13, 1878, p. 401.

surface of the lens, so situated as to be covered by the iris unless the pupil was dilated. Only a small part of the lens behind the bit of metal was opaque. Twenty-four hours later the effect of a powerful electro bar-magnet outside the eye was tried. When the pole of this magnet had been approached to a distance of four inches from the cornea, the chip was seen suddenly to spring away from the lens to the posterior surface of the cornea. On removal of the magnet the metal fell to the bottom of the anterior chamber, and was then extracted through an incision made as for iridectomy. The lens became afterward opaque throughout, and was then gradually absorbed.

*Gruening's Magnet* (Fig. 189) for the removal of particles of steel or iron from the vitreous chamber is manufactured by John Reynders & Co., New York.

Several magnets are joined into a bundle, thus making a powerful magnetic magazine, and concentrating the greatest possible magnetic polarity in the least possible dimensions. A long and delicate piece of malleable iron is fitted into one extremity of the bundle of magnets. As shown in the cut, the two extremities of a number of magnetized steel rods placed parallel to and at a little distance from each other, are fitted into iron caps, one of which is provided with a delicate point of malleable iron 3 mm. long, 1 mm. wide, and 0.3 mm. thick. This point is powerfully magnetic, sustaining with ease a weight of fifteen grammes. Chips of iron weighing from one to fifty centigrammes, when placed into the vitreous of recently enucleated animal eyes, are attracted toward the point at a distance of 1 to 5 mm., and withdrawn with the greatest facility. The instrument thus perfected equals Hirschberg's electro-magnet in efficiency, but surpasses it in simplicity of construction, convenience of form, and lowness of price.

*Electro-Chemical Baths—Removal of Poisonous Metals from the Body.*—In 1855 Vergnès and Poey, of Havana, reported to the French Academy a method of removing poisonous metals from the body by means of the galvanic current. Vergnès, while practising electroplating in 1852, had brought an obstinate ulceration on his hands. He placed his hands in an electric bath, connected with the positive pole. In fifteen minutes a metallic plate connected with the negative pole in the bath was covered with gold or silver from the ulcer. A few such treatments cured the ulcers.

An electro-chemical bath is taken as follows: An isolated metallic



FIG. 189.

tub is placed on an isolated bench. The tub is filled with water, acidulated with nitric acid of mercury, gold or silver, and sulphuric acid if lead is in the patient. The patient is placed in the bath, and the tub is connected with the negative pole, while the patient takes the positive pole, part of the time in the right and part of the time in the left hand. The current now enters the arms, and passes through the body to the tub. The metal that is extracted from the body is found on the sides of the tub, in the water in the tub, and in the atmosphere of the room from evaporation.

These experiments were confirmed by Caplin and Meding. Meding extracted mercury from a patient in this way. Vergnès employs electro-chemical baths also for introducing medical substances into the body. The patient sits in the bath containing the solution, and in the position described, and absorbs the substance while the current is passing. Among the remedies that Vergnès employs for the purpose are phosphate of iron and nitric acid. There is little question that the passage of the current through the body, immersed in certain medicated solutions, aids in the absorption of some portion of the compound. This whole subject, however, is yet in dispute, and will remain in dispute until it is carefully investigated by competent men, and all possible sources of error are guarded against.

*Faradic Anæsthesia.*—The benumbing effects of the faradic current on the nerves may be utilized for the production of local anæsthesia. (See *Electro-Physiology.*) It is only indicated for slight or at least short operations, such as the opening of abscesses, felons, buboes, the extraction of foreign bodies and of teeth.

For opening abscesses a strong faradic current should be directed through the parts as the incision is made. The relief thus afforded is slight, but is positive, and is not unworthy of a trial.

Faradic anæsthesia has been chiefly used in the extraction of teeth, where it is certainly of some service. The patient places his foot in a metallic slipper, or on a plate, or holds an electrode in the hand, while the circuit is completed as soon as the forceps of the dentist, which is connected with the battery, seizes the tooth. It is well to connect the forceps with the negative pole, because it is the stronger.

The contractions produced by the passage of the current are certainly disagreeable, for a current of considerable strength is required, but the pain of the extraction is less severely felt than it would be when made unaccompanied by the current.

This method of producing local anæsthesia was at one time somewhat popular among dentists, but partly on account of the fact that it is at



best an imperfect method of preventing the pain of the operation, partly on account of the mechanical difficulties in the way of its employment, and partly, also, on account of the popularization of nitrous oxide, it has fallen into disuse.

Faradic anæsthesia may be utilized for the relief of the irritation caused by the application of caustics to the larynx, eye, or uterus.

Dr. A. Tripier,\* of Paris, has recently advanced the theory that faradic anæsthesia is explained by the interference of the different impressions that are made on the nerve. The impression made by the faradic current first reaches the cerebral centre, and neutralizes, or, at least, diminishes, the impression made at the same time by any other irritating influence. This theory seems to us sensible and just. Dr. Tripier further recommends a return to the practice of faradic anæsthesia for slight operations.

*Hydro-Electrization.*—Dr. Beard has devised a method of applying electricity by means of a continuous stream or jet of water flowing from a metallic tube—or one that has a metallic orifice—connected with one pole, while the body of the patient is in any convenient way connected with the other. A jet or stream of water, so long as it is not broken into spray, will conduct the current from one-eighth of an inch to one or two inches from the orifice, according to the size of the stream, to any part where it may be applied. *Contractions of muscles, and all the effects of ordinary localized electrization, may be thus produced.*

This method of electrization is adopted for those localities where, on account of the natural sensitiveness, or from the nature of the disease, ordinary electrodes, by their mechanical irritation, cause unbearable pain, or where, for anatomical reasons, they cannot be applied.

For supplying a continuous stream of water we use an ordinary stiff rubber bag, which is filled with water in the usual way, by first compressing the sides and exhausting the air. Connected with this bag we use silver tubes of various shapes and sizes, provided with small thumb-screws for making the connection with the battery, and either insulated or non-insulated, according to the special purpose at hand.

The various douches that are used for the cavities of the body may be utilized for the same purpose, *provided the leather tubes are lined with spirals of wire, to keep up the connection of the current, or the tubes are composed of metal and insulated.*

On this principle, and in order to meet the same therapeutical indications for which ordinary electrization is employed, applications may

\* Archives of Electricity and Neurology. May, 1874, p. 109.

be made to the *external auditory canal*, and, in cases of rupture or ulceration of the *membrana tympani*, to the *middle ear*, by a straight, insulated tube, or by the ear-douche; to the *conjunctiva* by a single tube or by the ear-douche; to the *nasal passages* by the nasal douche or metallic posterior nasal syringe; to the *pharynx* and *naso-pharyngeal space* by a properly curved tube; to the *stomach* by the stomach-douche, such as has recently been used by Ploss, of Leipsic, or by the stomach-pump; to the *bladder* by the bladder-douche; to the *vagina* and *os* by the vaginal douche; and to the *cavity of the uterus* by the uterine douche; to the *cavities of opened abscesses*; to *stumps* that are slow to heal, and finally to all *irritable ulcers*, wherever situated.

Either the galvanic or the faradic current may be used, and the water may be pure or variously medicated. Warm water conducts better than cold, and is therefore preferable, except for those cases where the tonic effects of cold are indicated. The conducting power of the water is also increased by the addition of common salt, and various medicinal substances which are ordinarily used for the treatment of the conditions for which hydro-electrization is indicated, and may, therefore, be properly combined with it. Potter's hydro-therapeutic contrivances are very convenient for the purposes of hydro-electrization.

*Electro-Medication.*—Long ago it was contended by Fabr -Palaprat, Orioli, and Vergn s that medical substances could be introduced into the body by means of the galvanic current, but by Remak, Rosenthal, Tripier, and others their statements have been discredited. From our experiments it would seem that atropine might be introduced into the system by means of the faradic current in sufficient quantities to slightly affect the pupil.

Recently Beer, of Vienna, and Von Bruns\* have succeeded in introducing iodine into the dead and living subject, by means of the electrolysis of iodide of potassium. For this purpose they have used a glass tube, containing a solution of iodide of potassium (1 to 1, or 1 to 2), tightly corked at one end, and at the other covered with cloth or a piece of bladder, and connected through the cork with the negative pole of the galvanic current by a piece of platinum. The positive electrode may be of a similar construction, or an ordinary sponge electrode.

If by this arrangement an application be made through the face—an electrode being placed on each cheek—for a few minutes, traces of iodine can be detected in the saliva. A good test for iodine is *disul-*

\* Die Galvano-Chirurgie oder die Galvanokaustik und Elektrolysis bei chirurgischen Krankheiten. T bingen, 1870, p. 133 *et seq.*

*phide of carbon*, which will detect one part in 1,000,000 parts of water by the purple-red color which it produces. Another test is glycerine, which, mingled with iodine and electrolyzed, gives a dark-blue or black line. The electrolytic introduction of iodine has been used in *glandular swellings* (as goitre), *effusions in the joints*, *periostitis*, and with asserted success, after simple galvanization has failed. We have experimented in this direction considerably without arriving at any conclusive results.

The difficulty in all therapeutical experiments is that we are using simultaneously two remedies, iodine and electricity, both of which are separately efficacious in producing absorption.

*Podalgia*.—There are certain obscure painful affections of the feet that appear to be sometimes of a nervous character—a kind of hyperæsthesia—and sometimes appear to depend on actual injury of the bones or tendons. The former class—of which we have seen several cases—are really medical cases, and are to be treated by central and local galvanization. The latter are surgical cases and are to be treated by local applications.



## GLOSSARY.

---

*Explanation of the terms used in ELECTRO-THERAPEUTICS (Medical and Surgical), including also many of the terms of ELECTRO-PHYSICS and ELECTRO-PHYSIOLOGY.*

WITH the progress of the study of Electricity in its relations to Physics, Physiology, Practical Medicine, and Surgery, there has arisen a new and extensive terminology.

The terms used, especially in Electro-Therapeutics and Electro-Physiology, have been introduced by different observers, in various countries, and in different languages, and are all necessarily based on an incomplete knowledge of the mysterious force whose phenomena and manifold relations they aim to describe. It was inevitable that a nomenclature devised under such circumstances should be more or less inaccurate and confused. This inaccuracy and confusion have been still further increased by the carelessness of writers, who have misunderstood and misapplied these terms, and greatly perverted them from their original meaning. It would be difficult to find any two authors who entirely agree in their use of terms, even of those which are most frequent and most important; and readers who are not thoroughly familiar with all branches of the subject in the various languages, and with the incorrect as well as the correct phraseology, are constantly bewildered.

It is believed, therefore, that a list of the words and phrases employed by writers on Electricity, which should present their original and derived meanings in their various combinations, with their correct and incorrect synonyms, would be of service not only to those who consult this volume, but to all who occupy themselves with the department of Electro-Therapeutics.

The need for such a list is rendered the more imperative from the fact that many of the terms it includes cannot be found in the most recent dictionaries.

The terms which we have ourselves introduced, or to which we have given a new combination or attached a peculiar signification, are designated by a star (\*). The figures refer to the pages in the present work where the terms to which they refer are explained.

- AMALGAMATION.** To compound mercury (quicksilver) with another metal. In Electro-Physics, the term is usually applied to the covering of the zinc plates with mercury, by first pouring over them an acid solution and then dipping them in mercury, or pouring it over them.
- ANELECTROTTONOS.** The phase of *diminished irritability* which appears at the positive pole when a nerve is in the electrotonic condition
- ANIMAL ELECTRICITY**
- ANIONS.** In electrolysis the electro-positive substances that go to the cathode (Faraday)
- ANODE** (*ἀνα*, upward, and *ὁδός*, way). Where the current enters, called also *positive* or *copper pole* (Faraday).
- ANTOZONE**
- APPARATUS.** A contrivance or combination for a certain purpose; often used synonymously with *machine* or *battery*. Strictly, however, apparatus is applied only to the more simple contrivances, and machine to the more complex.
- ARMATURES.** Bars or *keepers*, which, when placed in contact with the pole of a magnet, preserve its magnetism.
- ASCENDING.** From periphery toward the centre, applied especially to the nervous system.
- BATTERY CURRENT** (see Galvanic Current).
- BATTERY, ELECTRIC** (or galvanic). A *series* of Leyden jars, or (more frequently) cells, connected together. The term is applied, however, to a *single* cell, and incorrectly also to a machine or apparatus.
- BOUND ELECTRICITY.** Electricity in the Leyden jar.
- CATALYSIS** (*κατά*, and *λύσις*, from *λύω*, to disengage). The absorption, and the accompanying transference of liquids caused by the chemical action of the galvanic current (Remak). It is a part and result of electrolysis.
- CATALYTIC.** Pertaining to catalysis.
- CATELECTROTTONOS.** The phase of *increased irritability* which appears at the negative pole when a nerve is in the electrotonic condition
- CATHODE** (*κατά*, downward, and *ὁδός*, way). Where the current passes out; called also *negative* or *zinc pole*
- CATIONS.** In electrolysis, the electro-negative substances that go to the anode (Faraday)
- CELL** (see Element).
- CENTRAL GALVANIZATION**\*
- CHEMICAL GALVANO-CAUTERY** (see Electrolysis).
- CHRONOSCOPE AND CHRONOGRAPH** (*χρόνος*, time, and *σκοπεῖν*, to observe). Instruments for measuring and recording the velocity of the nervous force, electricity, etc.
- CIRCLE GALVANIC**
- CLOSING CONTRACTIONS.** Contractions produced at the closing of the circuit.
- COERCITIVE FORCE**
- COIL INDUCTION.** Rolls of wire in which the current is induced by the alternate opening and closing of the circuit, as Rhumkorff's coil (see Induction).
- COMMUTATOR.** An arrangement for reversing the current.
- CONDENSER.** An apparatus for condensing a large quantity of electricity on a small surface.
- CONDUCTING WIRES.** The wires that conduct the electricity from the machine to the electrodes.
- CONDUCTIVITY** (or conductivity). That property by which a body conducts electricity.
- CONDUCTOR.** That which conducts electricity. Sometimes used for *electrode*.
- CONSTANT CURRENT.** The galvanic current from elements with two liquids. The constant batteries that are best known are those of Daniell, Grove, and Bunsen and their modifications (p. 26). Applied also to the *galvanic current* in general, and used synonymously with *continuous*. It is sometimes prefixed to galvanic current (constant galvanic) in the sense of *uninterrupted* (see Galvanic Current).
- CONTINUOUS.** Constantly flowing in one direction, sometimes used in the same sense as *constant* or *galvanic*. Strictly, it should be applied to the uninterrupted galvanic current, since the faradic current is always interrupted (see Galvanic Current).
- CONTINUOUS ELECTRIZATION.**\* This term might appropriately be applied to the protracted applications made by galvanic disks, belts, chains, poultices, etc., worn on the body.
- CONTRACTILITY, ELECTRO-MUSCULAR.** That property of muscles that causes them to contract, when acted upon by the electric current. It is to be distinguished from irritability, which it includes. Electro-muscular irritability may exist in muscles that have wholly lost their electro-muscular contractility (see Irritability).

- COPPER POLE** (see Positive Pole).
- CURRENT CHANGER** (see Current Reverser).
- CURRENT, ELECTRIC.** The continuous discharge of electricity that results from chemical action, such, for example, as takes place in any ordinary galvanic cell.
- CURRENT INCREASER.\*** A contrivance for increasing the strength of the current *without breaking the circuit*. A form of rheostat.
- CURRENT OF THE PILE** (see Galvanic Current).
- CURRENT REVERSER.** An arrangement for reversing the current.
- CURRENT SELECTOR.** A contrivance for bringing any desired number of elements into the circuit.
- CYLINDER MACHINE.** A form of machine for generating static electricity.
- DECLINOMETER.** An instrument for measuring magnetic declination. The *mariner's compass* is a declinometer.
- DENSITY.** Compactness. The density of a current, other conditions being the same, is in proportion to the smallness of the electrodes.
- DESCENDING.** From the centre toward the periphery.
- DIAMAGNETISM.** That property of bodies by which they manifest the same magnetic phenomena as iron.
- DIELECTRIC.** A medium through which induction is propagated.
- DIPLEGIC CONTRACTIONS**
- DIPOLAR ARRANGEMENT**
- DIPPING NEEDLE.** A needle for measuring the magnetic dip.
- DIRECT CURRENT** (see Descending current), also used for *galvanic current* (see Galvanic Current)
- DIRECT ELECTRIZATION**
- DRY** (or cutaneous) **FARADIZATION.** Faradization with dry electrodes
- DYNAMICAL ELECTRICITY**
- ELECTRIC** (electrical). Pertaining to, derived from, or containing electricity.
- ELECTRICS.** Those substances which, when held in the hand and rubbed, become electric.
- ELECTRIC BATH**
- ELECTRIC** (or metallic) **BRUSH.** A wire brush used as electrode.
- ELECTRIC** (or galvanic) **DISKS**
- ELECTRIC HAND.** The hand used as an electrode in electrization.
- ELECTRIC MOXA**
- ELECTRIC POINTS\*** (see Motor Points).
- ELECTRICIAN.** One who studies electricity in its *physical* relations, as in telegraphy; oftentimes used erroneously for electro-therapeutist.
- ELECTRICITY** (ἤλεκτρον, amber)
- ELECTRIFY.** This term is usually applied to the use of static electricity, and is therefore synonymous with franklinization. It is used sometimes synonymously with electrize.
- ELECTRIZATION.** The act of electrizing. The term includes faradization, galvanization, and franklinization, or the application of static electricity.
- For the sake of uniformity, and in order to preserve the distinction between the different methods of application, *electrization* has in this work usually been preferred to the periphrastic expression —the use of electricity.
- ELECTRIZE.** To affect by electricity.
- ELECTRO-ANÆSTHESIA.\*** The production of local anæsthesia by the application of electricity. The faradic current is used for this purpose (on faradic anæsthesia).
- ELECTRO-CHEMICAL.** Pertaining to electro-chemistry.
- ELECTRO-CHEMICAL BATH**
- ELECTRO-CHEMISTRY.** Electricity in its relations to chemistry, of which electrolysis is a branch.
- ELECTRODE** (ἤλεκτρον and ὁδός, way). The way by which the positive and negative electricities emerge. The positive pole is connected with the *negative* metal of the element, and the negative pole is connected with the positive metal.
- ELECTRO-DIAGNOSIS.** The use of electricity as a means of diagnosing disease (p. 263), called also *electro-pathology*.
- ELECTRO-DYNAMICS.** The phenomena of electricity in motion. Especially applied to the material attractions and repulsions of currents on currents, and currents on magnets.
- ELECTROLOGY.\*** Electricity in its relations to Physics, Physiology, Pathology, and Therapeutics, medical and surgical.

- ELECTROLOGIST.\*** One who is versed in electricity in its relations to Physics, Physiology, Pathology, and Therapeutics. That is, Electro-Physics, Electro-Physiology, Electro-Pathology (Electro-Diagnosis), and Electro-Therapeutics (Electro-Medicine and Electro-Surgery).
- ELECTROLYSIS** (ἤλεκτρον and λύω—through λύσις, disengaging). The act or process of decomposing a compound substance by electricity.
- ELECTROLYTE.** A substance which is susceptible of electrolysis.
- ELECTROLYTIC.** Pertaining to electrolysis.
- ELECTROLYZE.** To decompose a compound substance by the action of electricity.
- ELECTROLYZATION.** The act of electrolyzing.
- ELECTRO-MAGNET.** A bar of soft iron which, under the influence of the galvanic current, becomes magnetic.
- ELECTRO-MAGNETISM.** The phenomena of magnetism produced by an electric current.
- ELECTRO-MEDICINE.** Electricity in its relations to medicine.
- ELECTRO-MEDICAL.** Pertaining to electro-medicine.
- ELECTRO-MEDICATION.\*** The introduction of medicines into the body by means of electricity (p. 740).
- ELECTROMETER.** An instrument for measuring the charge of a battery.
- ELECTRO-MOTIVE FORCE**
- ELECTRO-MOTOR.** The metals that generate an electric current.
- ELECTRO-OTIATRICALS.** The electro-physiology or electro-therapeutics of the ear.
- ELECTRO-PATHOLOGY** (see Electro-Diagnosis).
- ELECTROPHORUS.** A contrivance for collecting electricity by induction.
- ELECTROPHORUS MACHINE**
- ELECTRO-PHYSICS.\*** Electricity in its physical relations.
- ELECTRO-PHYSIOGNOMY\***
- ELECTRO-PHYSIOLOGY**
- ELECTRO-PHYSIOLOGICAL ANATOMY.\***
- ELECTRO-PHYSIOLOGIST.** One who studies electricity in its physiological relations.
- ELECTRO-PUNCTURE.** The application of electricity (galvanic, faradic, or franklinic) by needles introduced beneath the surface.
- ELECTROSCOPE.** An instrument for detecting the presence of static electricity.
- ELECTRO-SENSIBILITY.\*** Sensibility of the body to electricity.
- ELECTRO-SURGERY.** The use of electricity, of any form, or by any method of application in surgical diseases. It includes *galvano-surgery*.
- ELECTRO-SUSCEPTIBILITY.\*** Susceptible to electricity, including farado-susceptibility and galvano-susceptibility.
- ELECTRO-THERAPEUTICAL ANATOMY\***
- ELECTRO-THERAPEUTICS.** The use of electricity of all forms to the treatment of disease. The term includes both medical and surgical electricity (electro-surgery); also *galvano-therapeutics* and *galvano-surgery*.
- ELECTRO-THERAPEUTIST.** One who studies electricity in its *Therapeutical* relations. Electro-therapeutists are frequently and erroneously called Electricians (see Electrician).
- ELECTROTONIC.** Pertaining to or derived from electrotonos.
- ELECTROTONOS.** The modification which a nerve-current undergoes when acted upon by the galvanic current
- ELECTRO-VITAL.** Pertaining to animal electricity, which is dependent on *vital* processes.
- ELEMENT** (couple, or pair, or cell), GALVANIC or VOLTAIC. Two heterogeneous metals immersed in acid solution. Thus we have Smee's, Grove's, Bunsen's, and Daniell's Elements, called also a *battery*, although strictly a *battery* means a series of elements.
- EXTRA CURRENT.** The current which is induced by any coil of wire on the adjacent coils of the same wire
- EXTRA-POLAR.** Not included in the intra-polar region between the poles
- FARADIC (FARADAY) CURRENT.** The induced current (p. 51). The term is applied both to the *electro-magnetic* and *magneto-electric currents*, since they were both discovered by Faraday. Called also *secondary*, *interrupted*, *induced*, *inductive*, *to and fro*, *indirect*, *electro-magnetic*, and *magneto-electric*. In this work the term *faradic* has been uniformly adhered to.
- FARADISM.** The phenomena of the faradic current. Sometimes used for *faradisation*.
- FARADIZE.** To affect by application of the faradic current.
- FARADIZATION.** Affecting by application of the faradic current. (According to our highest authority



in the orthography of this department of terminology—Mr. William Wheeler—*faradization*, as derived from Faraday, would be more consistent with analogy than faradization. The latter mode of spelling the word has the twofold advantage that it has been long used and is the more simple, and accordingly we have retained it in this work and in all our recent writings.)

- FARADO-CONTRACTILITY.** Contractility under the faradic current.
- FARADO-ELECTROLYZATION.\*** The simultaneous use of faradization and electrolyzation.
- FARADO-PUNCTURE.** Electro-puncture with the faradic current, not much used.
- FARADO-SUSCEPTIBILITY.\*** Susceptibility to the Faradic current.
- FRANKLINIC.** Pertaining to statical electricity.
- FRANKLINISM (FRANKLIN).** The phenomena of statical electricity.
- FRANKLINIZATION.** The application of statical electricity.
- FRictionAL ELECTRICITY.** Electricity generated by friction. It is one form of statical electricity, which is the wider term, including electricity generated by pressure or cleavage; but the terms are used synonymously.
- GALVANIC APPARATUS.** Apparatus for generating and furnishing the galvanic current.
- GALVANIC BELT**
- GALVANIC CHAIN**
- GALVANIC CIRCLE.** Two metals in a liquid—the galvanic element, pair or cell *in action* is called also a *current* or *chain*. A circle may be *single*—one cell or pair; or *compound*—several joined together.
- GALVANIC CURRENT.** A current generated by chemical action and coming directly from the cell, pile, or battery in which it is generated; distinguished from the faradic current, that is, induced on a coil of wires; called also *continuous, constant, direct, primary, current of the pile, battery current, and voltaic current*.
- GALVANIC (or Electric) DISKS**
- GALVANIC PAIR (see E'ement).**
- GALVANIC PRESSARIES (intra-uterine)**
- GALVANIC POUltICES**
- GALVANISM.** The science which treats of electricity that arises from chemical action; called also *voltaic or dynamical* electricity or voltaism. Physicists are of late inclined to prefer the terms derived from Volta; Physiologists and Physicians generally employ the terms derived from Galvani.
- GALVANIZATION** Affecting by application of the galvanic current.
- GALVANIZE.** To affect by application of the *galvanic* current, erroneously applied to all forms of electrization.
- GALVANIST.** One who uses galvanism (little used).
- GALVANO-CAUSTIC (see Galvano-cautery).**
- GALVANO-CAUTERISM.** The application of the galvanic-cautery (see Galvano-cauterization).
- GALVANO-CAUTERIZATION.** The act of burning or searing by a non-conducting-wire, heated by the galvanic current.
- GALVANO-CAUTERY.** Cauterization by a resisting wire (usually platinum), heated by the galvanic current; called also *galvano-caustic, or galvano-caustic*
- GALVANO-CONTRACTILITY.** Contractility under the galvanic current.
- GALVANO-PARADIZATION.\*** The *simultaneous* application of the galvanic and faradic currents.
- GALVANOMETER (or multiplier).** An instrument for determining the presence and direction and measuring the strength of a current. It is frequently used by electro-therapeutists in order to ascertain the dose of the galvanic current that they are giving. It is, however, only an approximately correct guide
- GALVANO-PUNCTURE.** Electro-puncture with the galvanic current.
- GALVANOSCOPE.** An instrument for indicating the *presence* of dynamical electricity without determining its amount.
- GALVANO-SURGERY.** The application of the *galvanic* current to surgery, a part of electro-surgery.
- GALVANO-SUSCEPTIBILITY.\*** Susceptibility to the galvanic current.
- GALVANO-THERAPEUTICS.** The application of the *galvanic* current to therapeutics, a part of electro-therapeutics.
- GENERAL ELECTRIZATION \***
- GENERAL FARADIZATION.\*** General electrization with the faradic current
- GENERAL GALVANIZATION.\*** General electrization with the galvanic current
- HELIX.** The coil of wires of the electro-magnetic apparatus
- HYDRO-ELECTRIZATION.\*** The application of electricity by means of water as an electrode

- INCREASING CURRENT.\*** An application in which the strength of the current is gradually increased without breaking the current, called also *swelling current*.
- INDIRECT ELECTRIZATION**
- INDUCED (or Induction, or Inductive) CURRENT.** As usually understood, the current which is induced in a coil of wires from another coil through which the current passes. Currents may, however, be induced in any metallic conductor from any other metallic conductor that is traversed by the electric current, or from powerful magnets, or from the magnetic action of the earth.
- INDUCING CURRENT.** The current that gives rise to an induced current.
- INDUCTION**
- INDUCTIVE (see Induced Current).**
- INTENSITY.** Strength of currents erroneously used for tension.
- INSULATOR (or Isolator).** A bad conductor of electricity.
- INSULATED.** Placed on non-conducting supports, or covered with some non-conducting substance.
- INTERRUPTED CURRENT.** Broken, intermitted. The faradic current is necessarily interrupted by the apparatus that generates it. The galvanic current may be either continuous or interrupted.
- INTRA-POLAR.** Between the poles
- IONS.** The constituents into which the electrolyte is decomposed
- IRRITABILITY.** That property of organized substances that causes them to respond to stimuli.
- IRRITABILITY, ELECTRO-MUSCULAR.** The property of muscular fibre that causes it to be excited to movement by the electric current. Electro-muscular irritability may exist without electro-muscular contractility; that is, the muscles may quiver or be spasmodically excited by even a mild current, even when they fail to contract under a very powerful current.
- IRRITABILITY, PRIMARY, SECONDARY, AND TERTIARY.** Degrees of irritability that are observed during a séance of galvanization
- LABILE CURRENT (or application).** An application in which one or both of the electrodes is moved or glided over the surface.
- LEYDEN JAR.** A glass bottle partially coated with tinfoil, for condensing statical electricity.
- LOCAL ELECTRIZATION.** Application of electricity to some part or organ, as distinguished from general electrization, in which the application is made all over the body. *Local* is practically synonymous with *localized* electrization, although, strictly speaking, localized implies that the direct action of the current is confined to the part to which the application is made, while local does not suggest any such meaning. According to this distinction, electrization may be local without being necessarily localized. For the sake of uniformity, the term localized has been generally adhered to throughout this work, to distinguish all local applications of electricity (see Localized Electrization).
- LOCALIZED ELECTRIZATION (p. 351) (see Local Electrization).**
- MACHINE (Electric or Electrical).** Any mechanical contrivance that generates any form of electricity; also called *electric apparatus*, but strictly is more complex than apparatus. Thus, for example, we have Holtz's machine for statical electricity; Kidder's machine for the galvanic and faradic currents, etc.
- MAGNETISM.** The power which certain bodies possess of attracting iron.
- MAGNETIZATION.** The act of magnetizing.
- MAGNETO-ELECTRICITY.** The current induced by a magnet, as in the magneto-electric or rotary apparatus. It is one form of the faradic current, of which the electro-magnetic is the other
- MAGNETOMETER.** An instrument for measuring magnetic declination.
- MAGNETS.** Substances that have the property of attracting iron.
- MOLECULES.** The minute particles of which bodies are composed
- MOTOR POINTS.** Points on the body where the nerves and muscles most readily respond to electrization; more specific than electric points, which is a general term, and includes all forms of reaction to the electric current.
- MULTIPLIER.** An instrument for multiplying or increasing a force—as heat or electricity. The term is applied both to the *galvanometer* and *thermo-multiplier*
- NEGATIVE MODIFICATION**
- NEGATIVE POLE.** Where the current passes out; called also *sine-pole* or *cathode*. The current is felt stronger at the negative than at the positive pole.
- NEGATIVE VARIATION**
- NERVE-MUSCLE CURRENT**
- OPENING CONTRACTIONS.** Contractions produced at the opening of the circuit.
- OZONE**

- PARAMAGNETISM.** That property of bodies by which they manifest magnetic phenomena opposite and corresponding to iron
- PERIPHERAL ELECTRIZATION.** Electrization of the periphery.
- PERIPOLAR ARRANGEMENT**
- PILE-LIKE ARRANGEMENT**
- PLATINUM** (or Platina) (from Spanish platina, silver). A metal used in electrical researches.
- PLEXUS-NERVE CURRENT**
- POLAR.** Relating to the poles.
- POLARITY OF ELECTRICITY.** That property of electricity by which peculiar phenomena of the positive and negative are exhibited at certain points (p. 27). Polarity of a nerve is that condition of a nerve by which one part is exhibiting a positively and the other a negatively electric state.
- POLARIZABLE.** Susceptible of polarization.
- POLARIZATION.** The act of giving polarity to a body in batteries
- POLAR METHOD.** The method of application by which the distinctive and differential action of each pole is obtained, by placing one pole over the part to be affected and the other in some indifferent point; called also *unipolar*.
- POLARIZE.** To communicate polarity to.
- POLARIZING.** Giving polarity to.
- POLARIZING CURRENT.** The current that produces the electrotonic condition.
- POLES.** Points where magnetism is concentrated, or where the electric current passes in or out. The terms *positive* and *negative* are relative, not absolute, since their position varies with the relative position of the electrodes.
- POSITIVE MODIFICATION**
- POSITIVE POLE.** Where the current enters, called also *copper pole* or *anode*
- PRIMARY CURRENT OF INDUCING CURRENT.** The current that passes through the inner coil of wire in a helix, and that induces a current on the coil that surrounds it (p. 62). Used erroneously as synonymous with *galvanic* or constant current.
- PROTRACTED APPLICATIONS.\*** Applications that are made for a very long time. Applications of galvanic belts, disks, and poultices are protracted.
- QUALITY OF A CURRENT,** as distinguished from quantity and intensity, refers to its smoothness or harshness, or to the rapidity or slowness of interruption.
- QUANTITY**
- ELECTRIC REACTION.** The phenomena developed by any part of the body under the influence of electricity.
- REACTION (GALVANIC).** (See Electric Reaction.)
- REOPHORE.** An Electrode.
- RESISTANCE.** The opposite of conductivity. That property of bodies that makes them resist or oppose the passage of the current
- REVERSE CURRENT** (see Ascending Current).
- RHEOCORD.** An instrument for controlling the fluctuations of the current.
- RHEOMOTOR** (see Electromotor).
- RHEOTOME** (*ῥέω τέμνειν*, to cut). A current breaker
- RHEOSTATE**
- ROTARY MACHINE.** Magneto-electric machines, in which the induced electricity is generated by turning a crank.
- SECONDARY CURRENT.** The faradic current, called also the *interrupted, induced, inductive electro-magnetic, faradic*, etc.
- SENSIBILITY, ELECTRO-MUSCULAR.** The peculiar subjective sensation which is experienced by the contraction of a muscle under the electric current.
- SHOCK.** A sudden single discharge of electricity, such as is given from a Leyden jar, or apparatus for statical electricity.
- SPARK, ELECTRIC.** The spark that attends the discharge of electricity on the passage of the current from one conductor to another.
- SPINAL-CORD CURRENT  
 SPINAL-CORD MUSCLE CURRENT  
 SPINAL-CORD NERVE CURRENT  
 SPINAL-CORD PLEXUS CURRENT  
 SPINAL-CORD ROOT CURRENT
- STABLE CURRENT** (or application). An application in which both electrodes are kept in a fixed position.

- STATIC ELECTRICITY.** Electricity in *rest*, generated by friction, pressure, or cleavage
- STRENGTH OF THE CURRENT**
- SWELLING CURRENT** (see *Increasing Current*).
- TENSION**
- TETANIZATION.** The production of a tetanic state in a nerve by passing a galvanic current through it.
- THERMO-ELECTRICITY.** The electricity that is generated by heating two heterogeneous conductors at their point of junction
- TO-AND-FRO CURRENT** (see *Faradic Current*).
- UNIFORM CURRENT.\*** A current that is kept at the same strength during the application.
- UNIPOLAR METHOD OF APPLICATION.** One pole on the part that is to be affected, and the other on some indifferent point; called also *polar method*.
- UNINTERRUPTED.** Unbroken, continuous (see *Continuous*). Applied only to the galvanic current, since the faradic is always interrupted by the machine that generates it.
- UNIT**
- UNPOLARIZABLE.** Not susceptible of being polarized.
- VOLTA-ELECTRIC INDUCTION** (see *Induction*).
- VOLTAIC ALTERNATIVES.** Changes in the direction of the galvanic current.
- VOLTAIC PILE OR BATTERY** (Volta). A series of elements so arranged that the zinc of one element is connected with the copper of the other
- VOLTAIC CURRENT** (Volta) (see *Galvanic Current*).
- VOLTAISM** (see *Galvanism*). Although the honor of giving the name to electricity generated by chemical action is really deserved both by Volta and Galvani, and has, to a certain extent, been accorded to both, yet the term galvanism with its derivatives has practically secured an ascendancy which it will probably retain.
- VOLTAMETER.** An apparatus for testing the strength of the current by measuring the quantity of gas given off in a given time during the decomposition of water
- Working up the Base.\** Electrolysis of the Base of tumors.
- ZINC POLE** (see *Negative Pole*); called also *cathode*.

# INDEX.

- ABBREVIATIONS in Electro-therapeutics, 260**  
 Acute diseases, 650, 628  
 Adenitis, 715  
 Addison's disease, 637  
 Adjustable electrode, 321  
 After-effects of electrical treatment, 294  
 Acne, 599  
     Rosacea, 510  
 Ague, 637  
 Aldini's researches in Animal Electricity, 91  
 Alopecia, 515  
 Alcoholism, chronic, 651  
 Amalgamation of zinc, 25  
 Amaurosis, 586  
 Amblyopia, 586  
 Amenorrhœa, 529  
     Prognosis in, 534  
     Cases of, 534  
 Ampère's theory of Magnetism, 51  
 Anæsthesia, 446  
     Tactile sensibility in, 446  
     Farado sensibility in, 446  
     Electro-diagnosis, 448  
     Prognosis, 449  
     Treatment, 448  
     Cases of, 449  
 Anæsthesia, cutaneous, 509  
 Anæsthesia, electro, 110  
 Anæsthesia, hysterical, 450  
 Anatomy, electro-physiological, 153  
 Anatomy, electro-therapeutical, 283  
 Anelectrotonos, 101  
 Anelectrotonos, theory of, 103  
 Angiomata, 686  
 Aneurism, 716  
 Aneurism, statistics of, treated by electricity, 717  
     Cases of, 718  
 Angina pectoris, 616  
 Ani, prolapsus, 570  
 Animal electricity, 87  
     History of its discovery, 90  
     Aldini's researches, 91  
     Humboldt's researches, 90  
     Du Bois-Reymond's researches, 91  
     Nobili's researches, 91  
     Matteucci's researches, 91  
     Apparatus for studying, 94  
 Anosmia, 645  
     Cases of, 646  
 Apparatus for electro-therapeutics, 291  
 Antozone, 650  
 Aphonia, 571  
     Prognosis, 575  
     Treatment of, 573  
     Cases of, 576  
 Applications of electricity, care in details, 240  
     Time of day for, 242  
     Time of, 243  
 Applications, Frequency of, 244  
     Prolonged, 245  
     Combination of methods, 246  
 Armatures, magnetic, 6  
 Artificial magnets, 3  
 Arthritis nodosa, 488  
 Artificial respiration, 612  
 Ascites, 644  
 Aspermatism, 563  
 Asphyxia, 612  
 Asthenopia, 584  
 Asthma, 496  
 Astraphobia, 415  
 Ataxia, locomotor, 474  
 Atrophy, progressive muscular, 478  
     Cases of, 479  
 Auditory nerve, galvanization of, 131  
     Reaction of, 592  
     Normal formula of, 131  
     Changes of reaction in, 592  
     Hypertæsthesia of, 592  
     Anæsthesia of, 593  
**BACTERIA, action of electricity on, 194**  
 Baths, electric, 395  
 Baths, electro-chemical, 737  
 Batteries, galvanic, 30  
     Wollaston's, 38  
     Daniell's, 32  
     Grove's, 33  
     Bunsen's, 34  
     Thermo-electric, 63  
     Farmer's thermo-electric, 64  
     Cabinet, 309  
     European, 326  
     Becker-Muirhead, 328  
     Marine, 39  
     Callan's iron-zinc, 38  
     Gas, 31  
     Polarization in, 30  
     Double-cell constant, 32  
     Bunsen's bichromate, 35  
     Walker's single-cell, 35  
     Smee's, 36  
     Leclanché's, 37  
     Water, 39  
 Bed-sores, 726  
 Belts and chains, 445  
     Pulvermacher's, 445  
     Galvanic, 445  
 Benign tumors, 686  
 Bioscopy, electro, 281  
 Bladder, diseases of, 566  
     Paralysis of, 568  
     Dissolution of calculi, 733  
 Blepharospasm, 586  
 Blood, action of electricity on, 164  
 Branch currents, 29

- Bright's disease**, 644  
**Boils**, 729  
**Brass ball**, 320  
**Brain**, action of electricity on, 112  
**Brenner's apparatus**, 316  
**Burners for galvano-cautery**, 678  
**Buboec**, 569  
**Bunsen's battery**, 34  
**Burns**, 729  
**Byrne's galvano-cautery apparatus**, 674
- CABINET battery**, 309  
**Calculi in bladder**, dissolution of, 733  
**Callan's iron-zinc battery**, 38  
**Cancer treated by electricity**, 702  
**Cancer**, relief of pain of by galvanization, 714  
**Carbuncles**, 729  
**Cataract**, 589  
**Catarrh**, 644  
**Catelectrotonos**, 101  
**Catelectrotonos**, theory of, 103  
**Central galvanization**, 376  
   **Electrodes for**, 380  
   **Battery for**, 380  
   and localized galvanization, 383  
   and general faradization, 384  
   **History of**, 214  
   **In the treatment of skin diseases**, 505  
**Cephalalgia**, 430  
**Cerebral congestion**, 421  
**Cerebro-spinal fever**, 630  
**Chilblains**, 729  
**Children, new-born**, resuscitation of, 614  
**Children**, diseases of, 545  
   **Chorea**, 545  
   **Whooping cough**, 545  
   **Cholera infantum**, 545  
   **Laryngismus stridulus**, 545  
   **Marasmus and debility**, 545  
   **Incontinence of urine**, 544  
   **Vomiting**, 545  
   **Infantile paralysis**, 545  
**Chloride of silver battery**, 308  
**Cholera-infantum**, 551  
**Chorea**, 545  
   **Treatment of**, 545  
   **Prognosis**, 546  
   **Cases of**, 546  
**Chromatogenous diseases**, 514  
**Chronic alcoholism**, 651  
**Cilio-spinal centre**, 115  
**Circles, galvanic**, 22  
**Cirrhosis of the liver**, 643  
**Club-foot**, 733  
**Coil, primary**, 57  
**Coils, induction**, 57  
   **Ruhmkorff's**, 58  
**Conduction, the converse of resistance**, 70  
**Condenser of Ruhmkorff's coil**, 59  
**Congestion, spinal**, 421  
   **Cases of**, 422  
**Constant batteries, double-cell**, 32  
**Constipation, nervous**, 521  
   **Prognosis**, 521  
   **Cases of**, 522  
   **Internal applications in**, 523  
**Contact and chemical action, theory of**, 43  
**Contractions, closure**, 274  
**Contractions, opening**, 274  
**Contractions, muscular**, 497  
**Contractility, electro-muscular**, 148  
**Contractions, diplegic**, 279  
   **Galvano-tonic**, 145  
**Convalescence**, 651  
**Cough, nervous**, 578  
**Coughing produced by electrizing the pneumogastic**, 121  
**Cornea, opacities of**, 587
- Coulomb's theory of magnetism**, 4  
**Crimp, writer's**, 490  
**Current, break**, 56  
   **Extra**, 56  
   **Chemical action, the origin of**, 26  
   **Derived or partial, or branch**, 20  
   **Induced, properties of**, 60  
**Curvature, spinal**, 732  
**Cutting loops for galvano-cautery**, 678  
**Cystic tumors**, 692
- DANIELL'S battery**, 32  
**Deafness, hysterical**, 599  
   **Following cerebro-spinal fever**, 601  
**Definition of electricity**, 2  
**Derived currents**, 29  
**Density**, 12  
**De Watteville, on the laws of electrotonos**, 104  
**De Watteville, on the excitability of cutaneous nerves**, 111  
**Diabetes**, 641  
**Diarrhoea, chronic**, 521  
**Digestion, diseases of the organs of**, 517  
   **Electro-diagnosis**, 517  
   **General principles of treatment in**, 517  
**Diphtheritic paralysis**, 628  
**Diplegic contractions**, 279  
**Disks, galvanic**, 445  
   **In myalgia**, 486  
**Dose of electricity**, 236  
**Double-cell-constant batteries**, 32  
**Drescher's galvanic battery**, 313  
**Dropsy**, 644  
**Du Bois-Reymond's researches in animal electricity**, 91  
**Duchenne and Remak**, 209  
**Duchenne's apparatus**, 327  
**Dynamical electricity, terminology of**, 51  
**Dyspepsia**, 519  
**Dysmenorrhoea**, 529  
   **Membranous**, 537  
   **Due to spasm of the os uteri**, 539  
**Dysphagia, from spasms of the pharynx**, 497  
**Dysphonia, cases of**, 577
- EAR, diseases of**, 590  
   **Internal method of electrization of**, 591  
   **External method of electrization of**, 592  
   **Electro-diagnosis of the diseases of**, 592  
   **Middle, chronic suppuration of**, 601  
   **Middle, subacute inflammation of**, 601  
**Eczema**, 505  
**Effects of electrical treatment, how to judge of the**, 247  
   **Of localized electrization**, 343  
   **Of general faradization**, 364  
**Electrical relation of elements**, 24  
   **Treatment, after effects of**, 258  
**Electricity, frictional**, 8  
   **Statical**, 8, 390  
   **Distribution of**, 11  
   **Magneto**, 60  
   **Thermo**, 63  
   **Animal, Reymond's theory of**, 91  
   **Statical use of**, 390  
   **Animal**, 87  
   **Induced**, 51  
   **A mode of motion**, 27  
   **Franklinic**, 8  
   **Loss of**, 9  
   **Polarity of**, 27  
   **Conversion of, into heat**, 29  
   **Nature and definition of**, 2  
   **In the living man**, 92  
   **Action of on the skin**, 105  
     **On the brain and spinal cord**, 112  
     **On the sympathetic and pneumogastic**, 116

- Electricity, action of on the nerves of special sense, 128  
 On motor and sensory nerves, and voluntary muscles, 141  
 On involuntary muscles, 158  
 Effects of on nutrition, 176  
 Mechanical, physical, chemical, and physiological effects of, 176  
 Effects on secretion and excretion, 185  
 Absorption, 188  
 Reflex effects of, 188  
 In plants and fruits, 194  
 General therapeutic action of, 217  
 Dose of, 236  
 Cumulative action of, 251  
 Its use by the laity, 259  
 Fishes, 89
- Electric machines, 12  
 Electric light, 28  
 Baths, 395  
 Effects of, 397  
 General rules for giving, 398  
 Moxa, 332  
 Explorer or probe, 734  
 Disks, 445
- Electrical endosmosis, 179  
 Electrization, localized, 331  
 History of, 207  
 Rationale of, 221  
 Instruments for, 331  
 With moistened electrodes, 332  
 Details of application of, 315  
 Of plexuses, nerves, and muscles, 341  
 Effects of, 343  
 In its relations to other forms of treatment, 258  
 Direct and indirect, 333
- Electro-anæsthesia, 110  
 Electro-chemical baths, 737  
 Electro-bioscopy, 281  
 Electro-conductivity of the human body, 168  
 Electro-diagnosis, 268  
 Electro-sensibility, 269  
 Electro-muscular contractility, 148  
 Sensibility, 148
- Electro-dynamical induction, 51  
 Electro-magnetic helix, 53  
 Machines, 57  
 Electro-magnetism, 51  
 Electrodes, 319  
 Metallic, 323  
 Unpolarizable, 325  
 Moistened, electrization with, 332  
 Brass ball, 320  
 Foot plate, 347  
 Uterine, 531  
 Intra-uterine, 531  
 Rectal, 523  
 Double uterine, 531  
 Vaginal, 533  
 Catheter, 563  
 Double vesical, 567  
 Adjustable, 321  
 Care of, 326  
 Polarization of, 31  
 Universal handle for, 319  
 Long sponge, 320  
 Hard rubber handle, 320  
 Duchenne's, 319  
 Stationary, 321  
 Spinal, 323  
 Current reverser, 324
- Electro-magnet in extraction of foreign bodies, 736  
 Negative, 28
- Electro-medication, 740  
 Electro-motive force, 66  
 Electro-muscular sensibility, 148-272  
 Electro-physics, 1  
 Electrometer, Thompson's quadrant, 16
- Electro-pathology, 268  
 Electro-physiology, 87  
 Electro-physiognomy, 153  
 Electro-physiological anatomy, 153  
 Electro-surgery, 655  
 History of, 655  
 Electro-therapeutics, history of, 198  
 Apparatus for, 291  
 Causes of failure in, 374  
 Electro-therapeutical anatomy, 283  
 Electrolysis, definition of, 45  
 History of, 45  
 Terminology of, 45  
 Laws of, 46  
 Theory of, 49  
 Its nature and general methods, 661  
 Needles for, 666  
 Of living and dead tissue, 180  
 Of the base, method of operating by, 668  
 Apparatus for, 663  
 Conductor for, 664
- Electrolyzing the base, 667  
 Electrophorus, 15  
 Electrophorus machine, Holtz's, 13  
 Electro-scope, gold leaf, 15  
 Electrotonos, definition of, 99  
 Molecular theory of, 99  
 Of muscle, 103  
 In the living man, 104  
 Practical bearing of its laws, 104
- Elephantiasis, 514  
 Elements, electrical relations of the, 24  
 Endosmosis, electrical, 179  
 Erectile tumors, 666  
 Epithelioma, 702  
 Epilepsy, 500  
 Cases of, 500  
 Epileptiform neuralgia, 434  
 Cases of, 435
- Exhaustion, nervous, 404  
 Exophthalmic goitre, 620  
 Extra current, 56  
 Extra-uterine pregnancy, 605
- Eye, diseases of, 581  
 Paralysis of the muscles of, 582  
 Electrization of, 581  
 Prognosis in paralysis of the muscles of, 582  
 Asthenopia, 584  
 Amblyopia and amaurosis, 586  
 Lid, spasm of, 586
- Eyelid, cases of spasm of, 587
- Eye, opacities of the cornea, 587  
 Ptosis, 588  
 Mydriasis and myosis, 588  
 Neuro-retinitis, 588  
 Strabismus, 588  
 Opacities, vitreous humor, 587  
 Photophobia, 587  
 Cataract, 589
- FACIAL neuralgia, 434  
 Cases of, 435
- Facial paralysis, 467  
 Cases of, 468
- Facial spasm, 497  
 Treatment of, 497
- Farad, 66  
 Faradic current, effects of, 107  
 Faradic anæsthesia, 738  
 Faradic and galvanic currents, comparative value of, 261  
 Faradization, era of, 207  
 Galvano, 266  
 Dry or cutaneous, 332
- Faradization, general, 347  
 History of, 211  
 Apparatus for, 350  
 Effects of, 364

- Faradization, rationale of, 370  
 Farado-sensibility, 288  
   Degrees of, 288  
   As compared with galvano-sensibility, 290  
 Farmer's thermo-electric battery, 64  
 Fatty tumors, 701  
 Feigned diseases, 316  
 Ferrier, researches of, 112  
 Fevers, 650  
   Convalescence from, 650  
 Fever, intermittent, 637  
 Fischer on electrization of the sympathetic, 127  
 Fishes, electric, 89  
 Fistula, 726  
 Flatulence, 527  
 Fibroids, 638  
 Force, electro-motive, 66  
 Fothergill's disease, 434  
 Foveaux's battery, 328  
 Franklinization, 390  
 Franklinic electricity, action of, 107  
   Era of, 199  
 Fritsch, researches of, 112  
 Franklinization, methods of, 392  
   Apparatus for, 393  
 Frictional electricity, 8  
 Frost-bite, 729  
 Furuncles, 729
- GAIFFÉ, battery of, 327  
 Galvani's researches, 43  
 Galvanic batteries, 30  
 Galvanic current, effects of, 109  
 Galvanic and faradic currents, comparative value of, 261  
 Galvanic belts and disks, 445  
   Circuits, compound, 28  
   Circuits, homogeneity of, 23  
 Galvanism, 19  
   Early history of, 42  
   Era of, 203  
 Galvanization, central, 376  
   History of, 214  
   Of the head, 335  
   Of the sympathetic, 336  
   Of the pneumogastric, 337  
   Of the spine, 338  
 Galvano-cautery, history of, 673  
   Apparatus for, 673  
   Uses of, 681  
   Advantages of, 681  
   Advantages of, over the actual cautery, 673  
   Burners and cutting-loops for, 678  
   Rules for the use of, 682  
   Adaptation to various departments, 683  
   Byrne's, 674  
 Galvano-faradic Mfg. Co., 302  
 Galvanic apparatus, Drescher's, 313  
   Meyer and Meltzer's, 327  
 Galvano-puncture in sciatica, 442  
 Galvanometer, 40, 313  
   Thomson's reflecting, 41  
 Galvano-tonic contractions, 145  
 Galvanoscopes, 313  
 Gas batteries, 31  
 Galvano-faradization, 266  
 Galvanometer, astatic, 41  
 Gangrene, 729  
 General faradization, 347  
   History of, 211  
   Length of applications, 361  
   Application to spine, 356  
   Details of its application to different parts of the body, 352  
   Applications to the neck and throat, 353  
   Applications to the head, 353  
 General galvano-faradization, 354
- General faradization, applications to the upper extremities, 356  
   Applications to the lungs and heart, 357  
   Applications to the liver, spleen, and bowels, 357  
   Applications to the stomach, 357  
   Applications to the female genital, 358  
   Applications to the lower extremities, 358  
   Effects of, 364  
   Rationale of, 370  
   Persistence in treatment, 361  
 General and localized faradization, differential indications for the use of, 372  
 General therapeutical action of electricity, 217  
 Genito-urinary organs, diseases of, 559  
   Treatment of, 559  
   Electro-diagnosis, 561  
 Gleet, 568  
 Glosso-laryngeal paralysis, 464  
 Glottis, spasm of, 577  
 Gout, 601, 621  
 Gonorrhœa, 568  
 Gout, 483  
   Case of, 488  
   Rheumatic, 488  
   Treatment of, 488  
 Graves' disease, 620  
 Grove's battery, 33  
 Gustatory nerve, action of electricity on, 139
- HALL's faradic machine, 301  
   Twenty-cell battery, 315  
 Hay-fever, 650  
 Hematocele, 729  
 Hemorrhoids, 570  
 Hand as an electrode, 362  
 Head, galvanization of, 335  
 Headache, 430  
   Prognosis, 430  
   Cases, 431  
 Heart, galvanization of, 160  
   Diseases of, 615  
   Palpitation of, 615  
   Cases of, 615  
 Helix, 52  
 Hemiplegia, 463  
   Cases, 463  
 Hemorrhage, post-partum, 604  
 Herpes zoster, 511  
   Frontalis seu ophthalmicus, 511  
 Hernia, 733  
 Hiccough, 498  
 Hip-joint, 733  
 History of central galvanization, 214  
 History of electro-therapeutics, 198  
   General faradization, 211  
 Hitzig, researches of, 112  
 Humboldt's researches in animal electricity, 90  
 Hydatids of liver treated by electrolysis, 698  
 Hydrocele, 730  
 Hydro-electrization, 739  
 Hydrophobia, 498  
 Hydrostat, 302  
 Hypochondriasis, 402  
   Treatment, 403  
   Cases, 403  
 Hysteria and allied affections, 399  
   Electro-diagnosis, 399  
   Treatment, 399  
   Prognosis, 400  
   Cases of, 400  
 Hysterical paralysis, 455  
 Hysterical anæsthesia, 450  
 Hysterical deafness, 599
- ILRUS, 523  
 Impotence, 560  
   Causation, 561



- .potence, electro-diagnosis, 561  
   Treatment of, 561  
   Cases of, 563  
 Incontinence of urine, 551  
 Induced currents, different orders of, 54  
   Properties of, 60  
 Induction of a current on itself, 56  
 Induction, statical, 10  
 Induction coils, 57  
   Magnetic, 5  
   Electro-dynamical, 51  
   History of, 62  
 Infantile paralysis, 552  
   Examination of muscles, 552  
   Early symptoms, 552  
   Electro-diagnosis, 554  
   Treatment, 555  
   Prognosis, 555  
   Cases, 556  
 Insanity, 416  
   Cases of, 418  
 Infantum, cholera, 551  
 Interruptions, slow, comparative value of, 330  
 Insomnia, 413  
   Treatment, 413  
   Case of, 414  
 Intensity *vs.* quantity, 68  
 Intra-uterine electrode, 531  
 Intermittent fever, 637  
 Irritation, spinal, 408  
 Isolation, 633  
 Involuntary muscles, action of electricity on, 158  
 Irritability, restoration of, 103  
   Degrees of, 136  
   How long retained after death, 141  
 Iris, action of electricity on, 158  
 Invagination, 523  
  
**J**  
 Jar, Leyden, 16  
 Jaundice, 521  
  
**K**  
 KERATITIS, 587  
 Kidder's faradic apparatus, cut of, 295  
   Galvanic apparatus, 305  
   For galvano-cautery, 675  
   Rules for the use and care of, 297  
  
**L**  
 LACTEAL secretion, deficient, 604  
 Larynx, diseases of, 571  
 Laryngismus stridulus, 577  
 Larynx, external electrization of, 571  
   Anæsthesia of, 580  
   Hyperæsthesia of, 579  
 Lead palsy, 453  
 Leclanché's battery, 37  
 Leucorrhœa, 529  
 Leyden jar, 16  
   History of, 17  
 Leucoderma, 514  
 Lichen, 509  
 Localization absolute of electricity, impossible, 345  
 Light, electric, 28  
 Liver, cirrhosis, 643  
 Lightning, fear of, 415  
 Lipomata, 701  
 Localized faradization, history of, 207  
   Galvanization, history of, 209  
   Electrization, 331  
   Instruments for, 331  
   Details of application of, 335  
   Effects of, 343  
 Localized and general faradization, differential indications for the use of, 372  
 Locomotor ataxy, 474  
   Electro-diagnosis, 475  
   Treatment, 476  
   Prognosis, 475  
  
 Locomotor ataxy, cases of, 477  
 Lungs, diseases of, 618  
  
**M**  
 MACHINE, electric, Holtz's, 13  
   Electro-magnetic, 57  
 Magnet, Grœning's, 731  
 Magnets, artificial, 3, 431  
   Shape of, 6  
   Polarity of, 3  
 Magnetic armature, 6  
   Induction, 5  
 Magnetism, 2  
   Coulomb's, theory of, 4  
   Of rotation, 62  
   Of broken magnets, 4  
   Electro, 51  
   Ampère's theory of, 51  
   In headache, 431  
 Magnetization, 6  
 Magneto-electricity, 60  
   Electric machines, 301  
 Malignant tumors, 686  
 Marasmus, 550  
 Maritime battery, 39  
 Matteucci's researches in animal electricity, 91  
 Melanoderma, 514  
 Meyer and Meltzer's apparatus, 327  
 Mammary gland, diseases of, 604  
 Melancholia, 402  
 Menorrhagia, 529  
 Midwifery, 602  
 Migraine, 433  
 Milk, deficient secretion of, 604  
   Treated by electricity, 605  
 Miscellaneous medical diseases, 637  
   Intermittent fever, 637  
   Addison's disease, 637  
   Suppression of urine, 640  
   Diabetes, 641  
   Dropical effusions, 644  
   Bright's disease, 644  
   Catarrh, 644  
   Anosmia, 645  
   Odontalgia, 647  
   Hay fever, 650  
   Obesity, 651  
   Cirrhosis, 643  
 Morbus coxarius, 733  
 Motor points of muscles, 283  
   Nerves, action of electricity on, 141  
 Mother's marks, 686  
 Moxa, electric, 332  
 Multiple element battery, Byrne's, 674  
 Muscle, electrotonus of, 103  
 Muscular atrophy, progressive, 478  
 Muscular contractions, 497  
 Muscular rheumatism, 486  
   Treatment, 486  
   Cases of, 487  
 Myalgia, 486  
 Mydriasis and myosis, 588  
 Myosis and mydriasis, 588  
 Myo-sclerotic paralyses, progressive, 482  
  
**N**  
 NATURE of electricity, 2  
 Nævi treated by electrolysis, 687  
 Neck, applications to, 353  
 Needles for electrolysis, 664  
   Method of introducing for electrolysis, 667  
 Negative modification, 102  
   Variation of the muscular current, 102  
 Nerves, electrization of, 341  
 Nerve muscle current, 341  
 Nervous exhaustion, 404  
   Cough, 578  
   Dyspepsia, 517  
 Neurasthenia, 404  
   *vs.* anæmia, 404

- Neurasthenia, treatment, 404**  
     Prognosis, 405  
     Cases, 405  
**Neuralgia, 425**  
     Electro-diagnosis, 425  
     Treatment, 425  
     Prognosis, 427  
     Intercostal, 428  
     Central, 430  
     Cephalalgia, 430  
     Facial, 434  
     Epileptiform, 434  
     Spinal irritation, 408  
     Peripheral, 437  
     Gastralgia, 438  
     Sciatica, 441  
     Angina pectoris, 616  
     Galvanic belts and disks in, 445  
     Cases of facial, 434  
     Reflex, 444  
**Neuro-rectitis, 588**  
**Neutral line, 3**  
     Point, 102  
**Nipples, sore, 605**  
**Nipple shield, galvanic, 605**  
**Nobli's researches in animal electricity, 91**  
**Nutrition, effects of electricity on, 170**  
  
**OBESITY, 651**  
**Odontalgia, 647**  
**Oedema, 682**  
**Oesophagus, stricture of, 725**  
**Ohm's law, 65**  
**Opium poisoning, paralysis from, 454**  
**Ophthalmoscopic examination of the retina in galvanization of sympathetic, 124**  
**Optic nerve, action of the galvanic current on, 128**  
**Orchitis, 569**  
     Case of, 569  
**Ovaries, irritation and congestion of, 543**  
**Ovarian tumors, 701**  
**Ozone, 647**  
     Physiological and therapeutical effects of, 649  
**Ozonization, galvanic, 727**  
**Oxygen, ozonized, 647**  
**Ozonized oxygen, 647**  
     General properties of, 648  
  
**PARALYSIS, 452**  
     Accessories to electrical treatment of, 461  
     Time of beginning treatment in, 461  
     Classification, 452  
     Rheumatic, 452  
     Lead, 455  
     Syphilitic, 453  
     From opium poisoning, 454  
     Hysterical, 455  
     Central, 458  
     Glossopharyngeal, 464  
     Spinal sclerosis, 474  
     Infantile, 552  
     Peripheral, 467  
     Facial, 467  
     From pressure, 470  
     Reflex, 472  
     Caloric, 472  
     Progressive myo-sclerosis, 482  
     Agitans, 494  
**Pain of cancer, relief of, by galvanization, 714**  
**Palsy, shaking, 494**  
**Paraplegia, 466**  
     Electro-diagnosis, 466  
     Treatment, 466  
     Prognosis, 467  
**Paresis of muscles of eye, 582**  
     Of bladder, 568  
**Partial currents, 29**  
  
**Pathology, electro, 268**  
**Pathophobia, 402**  
**Pessaries, intra-uterine, galvanic, 543**  
**Petit mal, 500**  
**Pectoris, angina, 616**  
**Pflueger's law of contraction, 104**  
**Photophobia, 587**  
**Physiognomy, electro, 153**  
**Physiology, electro, 87**  
**Pile, voltaic, 30**  
     Dry, 40  
**Piles, 570**  
**Plexus nerve current, 341**  
**Pneumogastric, galvanization of, 337**  
     Action of electricity on, 116  
**Poles, how to distinguish, 307**  
**Podalgia, 741**  
**Potential of the electric current, 68**  
**Polarity of the circuit, 23**  
**Polarity of magnets, 3**  
     Of electricity, 27  
**Polarization of electrodes, 31**  
**Post-partum hemorrhage, 604**  
**Polypt, 702**  
**Positive modification, 102**  
**Pott's disease, 732**  
**Primary coil, object of the iron core in, 57**  
**Primary and secondary coils, differential action of, 144**  
**Probe, electric, 734**  
**Pityriasis, 510**  
**Progressive muscular atrophy, 478**  
     Electro-diagnosis, 478  
     Treatment, 478  
     Case of, 479  
     Muscular hypertrophy, 482  
     Myo-sclerotic paralysis, 482  
**Prolapsus uteri, 542**  
     Ani, 570  
**Prostate, enlargement of, 569**  
**Prurigo, 508**  
**Psoriasis, 510**  
**Pseudo-hypertrophic paralysis, 482**  
     arthrosis, 732  
**Ptosis, 588**  
  
**QUALITATIVE changes, 297**  
**Quantitative changes, 297**  
**Quantity of the electric current, 74**  
     Absolute and actual, 74  
**Quadrant electrometer, Thompson's, 16**  
  
**RADCLIFFE, DR. C. B., views of animal electricity, 93**  
**Reaction of degeneration, 297**  
**Rectum, scirrhus of, 710**  
**Restorative effect of electrization on voluntary muscles, 158**  
**Remak and Duchenne, 225**  
**Reflex effects of electricity, 200**  
**Remak's galvanic apparatus, 329**  
**Resistance, 82**  
     Effects of temperature on, 83  
**Rectum, diseases of, 628**  
**Reflex neuralgia, 444**  
     Paralysis, 472  
**Regurgitation, 526**  
**Resuscitation of new-born children, 614**  
**Respiration, artificial, 664**  
**Retina, ophthalmoscopic examinations of, during galvanization of sympathetic, 124**  
**Rheostat of Mayer and Wolff, 317**  
     Hydro, 317  
**Rheotome, 56**  
**Rheumatic paralysis, 452**  
     Gout, 458  
     Treatment, 488  
**Rheumatism, 483**

- Rheostat, 42  
 Rhinitis, 644  
 Ringworm, 513  
 Rotation, magnetism of, 62  
 Rosacea, acne, 510  
 Ruhmkorff's coil, 58  
 Rubber covers for conducting wires, 325
- SCIATICA, cases of, 441**  
 Scirrhus, 702  
 Sclerosis, spinal, 474  
 Sea-sickness, 527  
 Secondary and primary coils, differential action of, 144  
 Scleroderma, 513  
 Sensory nerves, action of electricity on, 141  
 Seminal emissions, 559  
 Sensibility, electro-muscular, 148, 272  
 Sequelæ of acute diseases, 628  
   Cerebro-spinal meningitis, 630  
   Diphtheria, 628  
   Typho-malarial fever, 632  
   Sun-stroke, 633  
 Shaking palsy, 494  
 Shape of magnets, 6  
 Shortening of muscles during a contraction, 146  
 Siemens-Meidinger battery, 328  
 Siemens rheostat, 317  
 Single coil and separate coil faradic machines, 292  
 Sick headache, 433  
   Case of, 433  
 Singultus, 498  
 Sinuses, 726  
 Skin, diseases of, 501  
   Treatment of, 502  
   Eczema, 505  
   Prurigo, 508  
   Lichen, 509  
   Anæsthesia, 509  
   Acne, 509  
   Rosacea, 510  
   Psoriasis, 510  
   Pityriasis, 510  
   Herpes, 511  
   Ringworm, 513  
   Scleroderma, 513  
   Chromatogenous diseases, 514  
   Leucoderma, 514  
   Melanoderma, 514  
   Elephantiasis, 514  
   Alopecia, 515  
 Smee's battery, 36  
 Solenoids, 52  
 Spark, electric, 14  
 Spasmodic stricture, 724  
 Spasms of the eyelid, 587  
   Facial, 497  
 Spasmus glottidis, 577  
 Spasmodic diseases, 490  
 Spermatorrhœa, 559  
 Sphincter, paralysis of, 570  
 Sphygmograph, experiments with, 125  
 Spinal congestion, 421  
   Case of, 422  
   Cord, direct electrization of, 114  
   Current, 341  
   Root current, 341  
   Cord, plexus current, 341  
   Nerve current, 341  
   Muscle current, 341  
   Curvature, 732  
 Spinal irritation, 408  
   Differential diagnosis, 408  
   Pathology, 409  
   Treatment, 410  
   Prognosis, 410  
   Cases of, 410
- Spinal sclerotic paralysis, 474  
 Spine, galvanization of, 338  
 Spondylitis, 732  
 Sprains, 731  
 Stammering, 499  
 Statical electricity, 8, 390  
   Induction, 10  
   Era of, 199  
   Use of, 390  
 Stöhrer, apparatus of, 327  
 Stöhrer's zinc-carbon battery, 328  
 Stomach, action of electricity on, 158  
 Strabismus, 588  
 Strain, 731  
 Stricture of the urethra, 721  
   Cases of, 722  
   Of the œsophagus, 725  
   Spasmodic, 724  
 Stumps after amputation, 729  
 Suggestions in regard to the therapeutical uses of electricity, 226  
 Sympathetic, action of electricity on cranial portion of, 118  
   Nerve, action of electricity on, 116  
   Galvanization of, 336  
   Action of electricity on the cephalic, thoracic and abdominal ganglia of, 119  
 Sunstroke, 633  
 Suppression of urine, 640  
 Surgery, electro, 655  
   History of, 655  
 Synovitis, 729  
   Case of, 729  
 Syphilis, 569
- TALIPES, 733**  
 Temperature of electrodes and operating-room, 242  
   Increase of, after electrization, 149  
 Tension of the electric current, 68  
 Tetanus, 498  
 Thermo-electricity, 63  
   Electric batteries, 63  
 Thomas, on extra-uterine pregnancy, 605  
 Thomson's quadrant electrometer, 16  
 Throat, applications to, in general faradization, 353  
 Tic-douloureux, 434  
 Tinnitus aurium, 597  
   Galvanization of sympathetic in, 598  
 Tonics, definition of, 218  
 Tonic effects of electricity, 218  
   In general faradization, 364  
 Toothache, 647  
 Torticollis, 492  
   Diagnosis of, 492  
   Electric examination of, 493  
   Treatment of, 493  
   Prognosis, 493  
   Cases of, 493  
 Trowbridge, experiments of, 95  
 Trocar, Duchenne's, 552  
   Noeggerath's, 552  
 Tschitiew, on cutaneous excitability, 111  
 Tubercula quadrigemina, direct electrization of, 124  
 Tumors, removal of by galvano-cautery, 683  
   Non-malignant, 626  
   Erectile, 626  
   Malignant, 686  
   Cystic, 593  
   Fatty, 701  
   Ovarian, 701  
 Typho-malarial fever, sequelæ of, 631
- ULCERS, 726**  
 Unit, 65

- Unpolarizable electrodes, 325  
 Ununited fracture, 732  
 Urethra, strictures of, 721  
   Cases of, 722  
   Hyperesthesia of, 561  
 Urethritis, chronic, 563  
 Urine, incontinence of, 551  
   Suppression of, 640  
 Uterine electrode, 531  
 Uterus, faradization of, 530  
   Diseases of, prognosis in, 529  
   Enlargements of, 542  
   Prolapsus, 542  
   Anteflexion of, 542  
   Retroflexion of, 542  
   Retroversion of, 542  
   Anteversión of, 542  
   Amputation of neck of, by galvano-cautery,  
     684  
   Congestion of, 542  
   Displacement of, 542  
   Atrophy of, 541  
   Fibroids of, 698  
 Uteri prolapsus, cases of, 542
- VAGINAL electrode, 533  
 Varicose veins, 716  
 Veins, varicose, 716  
 Vitreous humor, opacities of, 557  
 Viscera, abdominal, localized electrization of, 518  
 Volta constructs the voltaic pile, 30  
 Volta's researches, 43  
 Voltaic pile, 30  
 Voluntary muscles, action of electricity on, 141  
 Vomiting, 526, 551  
 Volta meter, 40
- WALKER'S single cell zinc-carbon battery, 35  
 Wart's, 733  
 Water rheostat, 317  
 Wesley, Mr., 201  
 Wires, conducting, rubber cover for, 325  
 Whooping-cough, 551  
 Wollaston's battery, 38  
 Women, diseases of, 529  
 Writer's cramp, 490  
 Wry neck, 492
- ZINCS, how to amalgamate, 26