

MUFON UFO JOURNAL

NUMBER 233

SEPTEMBER 1987

Founded 1967

OFFICIAL PUBLICATION OF



MUTUAL UFO NETWORK, INC.

\$2.50

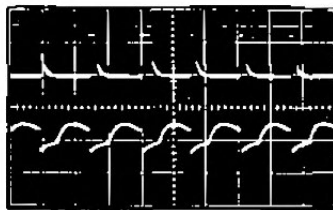

PLUG SIGNAL



COIL CURRENT



FIGURE THREE - Typical Signals at 450 RPM and 30 degrees Dwell

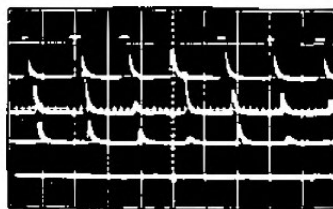

12.5 V
7.5 V
5.0 V
3.5 V

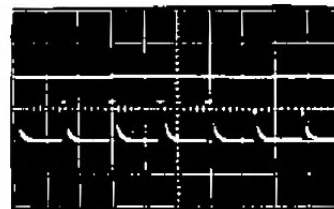

POINTS
SPARK PLUG

FIGURE FIVE - UNDERVOLTAGE

FIGURE SIX - Normal Signals at 13.5 Volts

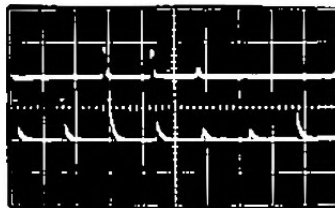

POINTS
SPARK PLUG

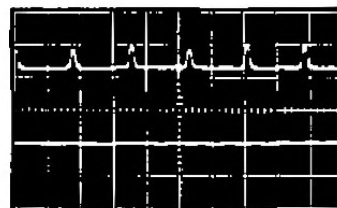

POINTS
SPARK PLUG

Onset of Points Arcing at 25 Volts

Spark Suppression at 40 Volts

FIGURE SEVEN

FIGURE NINE

THE VEHICLE INTERFERENCE EFFECT

MUFON UFO JOURNAL

(USPS 002-970)

(ISSN 0270-6822)

103 Oldtowne Rd.

Seguin, Texas 78155-4099 U.S.A.

DENNIS W. STACY
Editor

WALTER H. ANDRUS, JR.
International Director and
Associate Editor

THOMAS P. DEULEY
Art Director

MILDRED BIESELE
Contributing Editor

ANN DRUFFEL
Contributing Editor

PAUL CERNY
Promotion/Publicity

MARGE CHRISTENSEN
Public Relations

REV. BARRY DOWNING
Religion and UFOs

LUCIUS FARISH
Books/Periodicals/History

ROSETTA HOLMES
Promotion/Publicity

T. SCOTT CRAIN
GREG LONG
MICHAEL D. SWORDS
Staff Writers

TED PHILLIPS
Landing Trace Cases

JOHN F. SCHUESSLER
Medical Cases

LEONARD STRINGFIELD
UFO Crash/Retrieval

WALTER N. WEBB
Astronomy

NORMA E. SHORT
DWIGHT CONNELLY

DENNIS HAUCK
RICHARD H. HALL
ROBERT V. PRATT
Editor/Publishers Emeritus
(Formerly SKYLOOK)

The MUFON UFO JOURNAL is published by the Mutual UFO Network, Inc., Seguin, Texas. Membership/Subscription rates: \$25.00 per year in the U.S.A.; \$30.00 foreign in U.S. funds. Copyright 1987 by the Mutual UFO Network. Second class postage paid at Seguin, Texas. POSTMASTER: Send form 3579 to advise change of address to The MUFON UFO JOURNAL, 103 Oldtowne Rd., Seguin, Texas 78155-4099.

FROM THE EDITOR

Our lead article this issue represents the sort of independent research ufology is capable of, given persistence and an inquiring mind. Performed in a "home" laboratory and at a personal cost of several hundred dollars, Joe Kirk Thomas' study of the UFO Vehicle Interference Effect should serve as a model of applied science. We congratulate Mr. Thomas personally and appreciate his allowing us to share this study with MUFON Journal readers.

We also have on hand two items relating to the increasingly dubious Majestic-12 documents, publicly presented at the Washington Symposium earlier this year by William L. Moore. These include a response from a close friend and collaborator of Harvard astronomer Dr. Donald Menzel, named as one of the "MJ Twelve," and the report currently being released by the National Archives in response to the growing number of requests for MJ-12 and related documents. Our editorial policy is to present both sides of the argument and allow an informed readership to make up its mind accordingly. We are, after all, one hopes, after answers and not dogma.

In this issue

THE VEHICLE INTERFERENCE EFFECT by Joe Kirk Thomas	3
CONFERENCE UPDATE by Walt Andrus	11
NEWS'N'VIEWS	13
MENZEL MYSTERY by Walt Andrus	15
NATIONAL ARCHIVES MJ-12 RESPONSE	17
LOOKING BACK by Bob Gribble	18
LETTERS	20
THE OCTOBER NIGHT SKY by Walter N. Webb	22
DIRECTOR'S MESSAGE by Walt Andrus	24

The Mutual UFO Network, Inc. is exempt from Federal Income Tax under Section 501(c)(3) of the Internal Revenue Code. MUFON is a publicly supported organization of the type described in Section 509(a)(2). Donors may deduct contributions from their Federal income tax. In addition, bequests, legacies, devises, transfers, or gifts are deductible for Federal estate and gift tax purposes if they meet the applicable provisions of Sections 2055, 2106, and 2522 of the code.

The contents of the MUFON UFO JOURNAL are determined by the editor, and do not necessarily represent the official position of MUFON. Opinions of contributors are their own, and do not necessarily reflect those of the editor, the staff, or MUFON. Articles may be forwarded directly to MUFON. Responses to published articles may be in a Letter to the Editor (up to about 400 words) or in a short article (up to about 2,000 words). Thereafter, the "50% rule" is applied: the article author may reply but will be allowed half the wordage used in the response; the responder may answer the author but will be allowed half the wordage used in the author's reply, etc. All submissions are subject to editing for style, clarity, and conciseness. Permission is hereby granted to quote from this issue provided not more than 200 words are quoted from any one article, the author of the article is given credit, and the statement "Copyright 1987 by the Mutual UFO Network, 103 Oldtowne Rd., Seguin, Texas 78155" is included.

THE VEHICLE INTERFERENCE EFFECT

By Joe Kirk Thomas

Joe Kirk Thomas is a MUFON research specialist.

This article summarizes the results of recent laboratory experiments aimed at determining the cause of Vehicle Interference Effects. This syndrome, wherein automobile engines allegedly labor, lose power, and die in the vicinity of UFOs, predates Arnold, but came into prominence during the 1957 Levelland, Texas sighting. Surprisingly few theories have been advanced during the last 29 years since Levelland, and experiments testing those theories have been rare.

HISTORICAL BACKGROUND

One of the earliest theories of VIE was advanced by Richard Hall in *The UFO Evidence*¹, published in 1964. He proposed that the cause of VIE was the nuclear EMP (Electro Magnetic Pulse). This phenomenon had first been observed in 1952 when instrumentation was knocked out during a British nuclear test. The British called it "radioflash." In 1963, EMP made headlines when it became known that some U.S. satellites' electronic systems had similarly succumbed to atmospheric atomic tests during 1962. The late 1960s were also the era of ORION, a proposed interplanetary spacecraft to be propelled by ejecting and detonating a series of small nuclear devices behind a large shock absorbing pusher plate. Hall apparently reasoned that a similar propulsion system on a smaller scale might produce a substantial EMP threat, knocking out an automobile's electrical system.

In 1973, James McCampbell advanced a microwave theory in *Ufology*² and in subsequent symposia^{3,4}. That author hypothesized an anomalous increase in the resistivity of tungsten when irradiated with microwave radiation. Radiation with

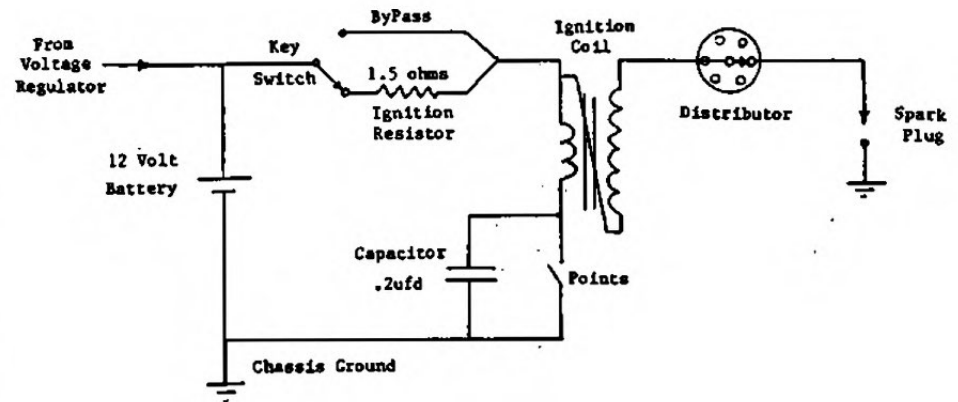

CONVENTIONAL AUTOMOTIVE IGNITION CIRCUIT

FIGURE ONE

wavelengths comparable to or smaller than the distance between the cooling fins of the radiator would pass through and flood the engine compartment. It was theorized that the resistance of tungsten elements in the distributor would be increased to the point that a spark could not be delivered to the plugs.

During its investigation, the Condon Committee arranged for the components of an ignition system to be subjected to powerful D.C. magnetic fields. Ignition coils were found to fail at 2 Telsa (20,000 gauss)⁵. The committee investigated a single case (which this author considers dubious) involving alleged engine interference and found the car's magnetic configuration to be essentially unchanged.

CRITIQUE OF EARLIER THEORIES

In the twenty years since Hall's EMP hypothesis, much has been learned about the spectrum and magnitude of the nuclear EMP. The protection of military electronic systems from this threat has become a discipline in itself, and information on it

is available in numerous unclassified books and articles. EMP is basically a large scale phenomenon having to do with the asymmetrical interaction of a nuclear burst and the atmosphere. Although one can hypothesize these phenomena to occur on a small scale, the radiation required to produce EMP would be extraordinarily lethal.

Furthermore, the majority of energy in EMP is in radio frequencies below 100 Mhz. The automobile hood forms a fairly credible RF shield against radiation in this regime. EMP is basically a threat to solid state electronics. The elements of a conventional automotive ignition system, however, particularly during the Levelland era, consists of items like transformers, resistors, and vibrating relays that are generally immune to the effects of EMP.

Two serious problems present themselves with regard to McCampbell's microwave hypothesis. Although a headlamp can extinguish from a fourfold increase in resistance, the resistivity of any tungsten elements in a distributor would have to increase by 10^3 or so.

Secondly, the hypothesized

is around 10,000 gauss. Solving for the above equation shows the shield starting to fail at 9.25 gauss. This is about 100 times smaller than the fields believed to be present.

A real engine compartment, of course, is nowhere near as perfect as our spherical model. Much of the bottom, for example, is open. Furthermore, the hood does not make a good magnetic connection with the rest of the car body. The gaps between hood and chassis degrade the shield even further.

The bottom line is simply that the automobile engine compartment is a *marginal* magnetic shield at best, and it fails in the presence of rather modest fields.

CONVENTIONAL IGNITION CIRCUIT

The author has restricted experiments to the conventional ignition circuit in widespread use at the time of the Levelland sightings. This circuit is shown in Figure One. The low voltage circuit consists of the battery, the ignition resistor, and primary winding of the ignition coil, capacitor and points. The high voltage circuit consists of the ignition coil secondary, distributor and spark plug. There is also a charging circuit which during the Levelland era generally consisted of a generator and a relay-voltage regulator.

In operation, current flows from the battery through the ignition resistor, the coil primary, and finally through the normally closed switch, or points, to ground. As the distributor rotor turns, however, an eight sided cam (for an 8 cylinder engine) forces the points open. This sudden interruption in coil current causes a large voltage to occur across the coil secondary (about 17 K.V. !). This voltage is sufficient to cause an arc in the distributor cap which directs the spark to the appropriate plug.

The voltage regulator usually contained three relays which connected the generator to the battery only when the generator output voltage was greater than battery voltage (thus charging the battery) and disconnected whenever the battery voltage became too high or the battery drew too much

current. Over the next two decades, this part of the ignition circuit underwent considerable changes with the use of alternators and electronic voltage regulators. The rest of the conventional system as shown in Figure One was in fairly general use into the 1970s. Most ignition systems today, however, are *electronic*, with the mechanical points and capacitor having been replaced by transistors.

Figure Two is the experimental setup used to simulate the ignition system in the laboratory. The distributor rotor is turned by a D.C. motor. A power amplifier replaces the battery. When the amplifier has 12 to 14 volts output and the rotor is turning, sparks are delivered to the plug. Two Pearson 411 current probes monitor the low voltage (coil primary) and high voltage (spark plug) currents. Optical sensors stare at the points and the spark plug. The spark plug light signal, being rather weak, is viewed through fiber optics placed close to the spark. The optical sensor's output is then amplified in a preamp. All signals are viewed with an oscilloscope.

Figure Three shows typical signals of an ignition system running at 450 rpm and tuned for a dwell of 30 degrees. The bottom trace is the current flowing through the low voltage circuit. At point "1" the points have just closed and the coil current rises to 4 amps. At point "2," the points open, interrupting the circuit and forcing the current to zero. The collapsing magnetic field in the coil

produces a high voltage in the coil secondary which produces an arc in the plug. The top trace is the spark plug optical signal. At point "3," the points again close and the process repeats.

To understand how an oscillating magnetic field can interfere with the electrical system, refer to Figure Four (a). Although drawn in schematic form, it shows that the various elements of an ignition system are spread out under the hood. For simplicity, assume that the circuit encloses an area A as shown. Since, as we have seen, the engine compartment provides little shielding, an external magnetic field will flux through this area. As a result, a voltage equal to the product of the time rate of change of the magnetic field, \dot{B} (read B-dot), and the *effective*¹³ area, A , is "induced" in the circuit. Figure Four (b) shows the "equivalent circuit." By breaking the circuit and placing a voltage source of magnitude $\dot{B}A$ in series with it, the same effect is had. The equivalent circuit is exploited in the experimental setup shown in Figure Two. Instead of immersing the laboratory setup in an oscillating magnetic field, a power amplifier is connected in series with the low voltage circuit and the appropriate signals injected.

INTERFERENCE MECHANISM

The postulated interference mechanism, as indicated earlier, is the voltage induced in the low voltage side

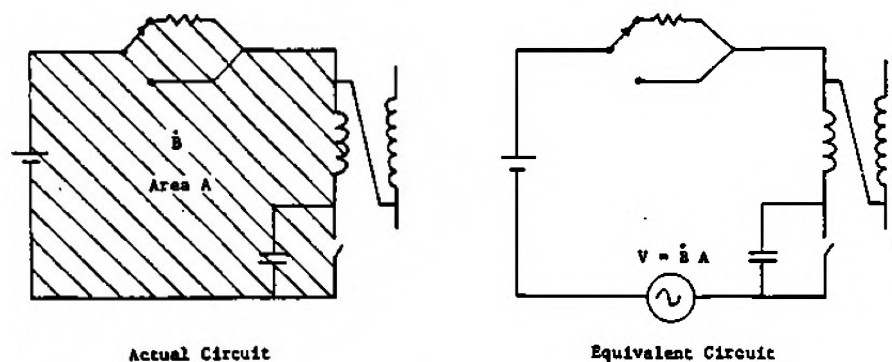

INDUCED VOLTAGES IN LOW VOLTAGE CIRCUIT

FIGURE FOUR

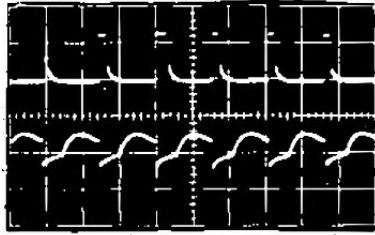

PLUG SIGNAL

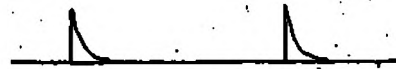

COIL CURRENT

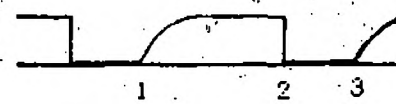
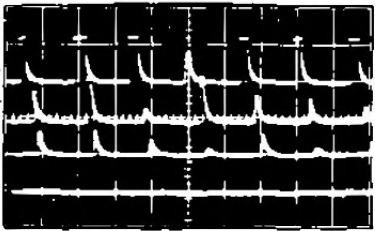
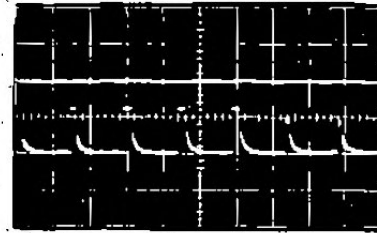

FIGURE THREE - Typical Signals at 450 RPM and 30 degrees Dwell



12.5 V
7.5 V
5.0 V
3.5 V

FIGURE FIVE - UNDERVOLTAGE



POINTS
SPARK PLUG

FIGURE SIX - Normal Signals at 13.5 Volts

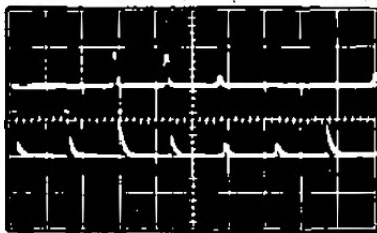

POINTS
SPARK PLUG

Onset of Points Arcing at 25 Volts

FIGURE SEVEN

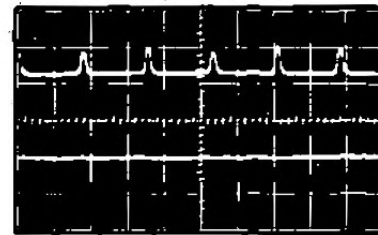

POINTS
SPARK PLUG

Spark Suppression at 40 Volts

FIGURE NINE

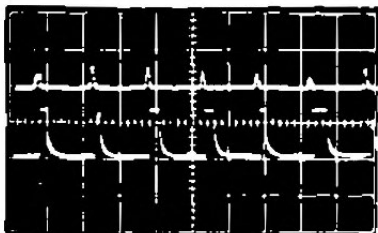

POINTS
SPARK PLUG

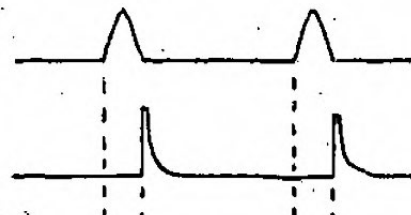

FIGURE EIGHT - Desynchronization at 30 Volts

of the ignition circuit by an external A.C. magnetic field.

Such a voltage can be either in the same direction as the battery voltage, thus increasing the total circuit voltage, or in the opposite direction, thus decreasing the total voltage. In either case, the current that flows through the loop is merely the net voltage divided by the total loop resistance. While the points are closed, the total resistance is simply that of the coil and the ignition resistor, usually about 3 ohms.

D.C. STUDIES

The effects of induced voltage on the ignition system can be studied by placing a direct current power supply in the circuit where the battery would normally be, and then varying the voltage.

The top trace (a) in Figure Five shows the optical signals from the spark plug when the voltage is 12.5 volts, a normal circuit voltage. If a 6 volt signal is induced in the circuit opposing the battery, the net voltage would be reduced to 7.5 volts. The second trace (b), with the power supply set to 7.5 volts, shows the spark signals slightly reduced in amplitude. The third trace (c), where the circuit voltage has been reduced to 5 volts, shows even smaller signals. The fourth trace (d), at 3.5 volts, shows no signals at all. Numerous observations with points and plugs of varying "age" have shown that below an extinction voltage of 3.5 to 4.0 volts, no spark signals are generated. This condition is called *undervoltage*.

The condition in which the induced voltage adds to the battery emf is somewhat more complex. To study this situation, called *overvoltage*, I monitored two optical signals, one being the spark plug, and the other the points. Figure Six shows these signals for a normal voltage of 13.5 volts. The lower trace shows no arcing across the points, a normal situation so long as the ignition capacitor is good.

As one increases the voltage, the only apparent effect, at first, is a brighter spark in the plug. Around 25 volts, however, arcs start to occur in the points, as shown in Figure Seven. After a few seconds, these arcs occur everytime the points open, as shown in

Figure Eight. Since the spark plug signals are still quite healthy, one might think that the impact on engine operation is nil. This isn't true. Careful examination shows that the spark plug signals have been *delayed* almost 10 degrees (of cam rotation). Thus, if the initial spark advance was set to fire 8 degrees (of crankshaft rotation) before TDC (top dead center), it is now delivered 12 degrees *after* TDC¹⁴.

How can this surprising result occur? Because the points are overvolted, as they open they draw an arc. Although the points have opened mechanically, electrically they are still closed. As the points separate, the arc elongates, cools, and extinguishes. When the arc collapses, a spark is delivered to the plug. Close to the onset of arcing, the arc decays quickly and the delay is therefore short. At higher voltage, the arc lasts longer and therefore the delay increases, all the way to a maximum of 15 degrees of cam rotation (the period over which the points are physically open). This corresponds to a crankshaft rotation of 30 degrees. This *desynchronization* usually sets in around 25 volts.

Figure Nine shows the signals at 30 volts (during which the current flowing in the circuit during points closure is 10 amps). The top trace shows large arcs being drawn during each "action" of the points. But now the arc doesn't collapse until the points close. As a result, the spark plug signals are *totally suppressed*, as shown in the lower trace. The *suppression voltage* varies with the age of the components and the time of exposure to overvoltage, but usually lies between 30 and 40 volts.

A.C. STUDIES

Direct current studies are useful in studying the response of the points and circuits to induced voltage. But only *changing* magnetic fields can induce voltages, and therefore, in a real encounter, the induced voltages are changing also.

Two basic types of excitation were studied in this experiment. Figure Ten (a) is a hypothetical field which "ramps" linearly from $-B_0$ to 0 to $+B_0$ and back again. Since the rate of change of the field is constant during ramps, the

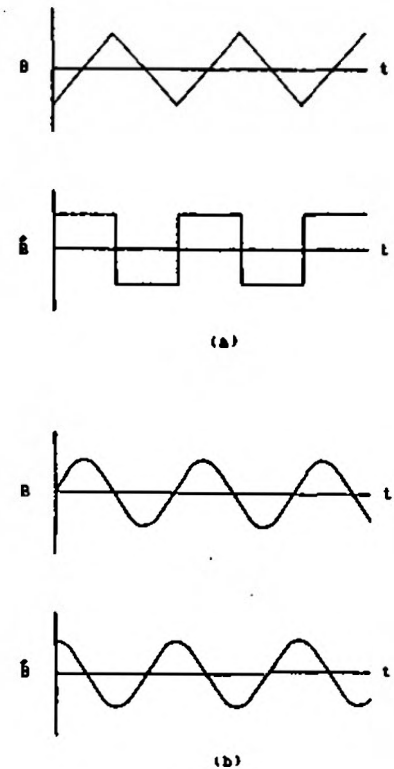

FIGURE TEN - Triangular and Sinusoidal Waveforms

voltage that would be induced in the primary side of the ignition circuit is as depicted in the lower trace. The magnitude of the induced voltage is the same, but it changes direction twice in each cycle. Figure Ten (b) shows a sinusoidal excitation. The peak induced voltage occurs when the magnetic field crosses zero, where the rate of change is greatest, and is zero when the field is at the maximum, B_0 , since the rate of change at this point is zero. The resultant induced voltage is shown in the lower trace.

What should the frequency of the external field be? Based on the apparent lack of gross motion of large ferromagnetic structures in CEII cases, the minimum frequency one would expect is about 10 hertz. The maximum frequency can be surmised from examination of the ignition circuit itself. The risetime of the coil current immediately after points closure indicates that the circuit has a "bandwidth" of about 100 hertz. Figure Eleven shows the relative circuit impedance as a function of frequency.

Between 0 and 100 hertz, this impedance is about 3 ohms, the D.C. resistance of coil and resistor. But beyond 100 hertz, the impedance increases due to the inductance of the coil. The rate of increase is about 10 for an increase in frequency of 10. Thus the susceptibility of the ignition system to this type of interference decreases rapidly above 100 hertz, which we will take to be the *maximum frequency* of the postulated external field.

During A.C. studies, a power amplifier provides both battery bias and interfering signals. Figure Twelve shows normal waveforms with the amplifier output at about 12 volts. The signal is somewhat rough as the ignition circuit is a rather noisy load. The spark plug optical signals appear on the lower trace.

Figure Thirteen shows the plug signal (lower trace) when a +/- 12 volt, 13 hertz signal is added to the "battery" voltage (upper trace). During the positive part of the waveform, the total circuit is 24 volts, in the desynchronization regime. During the negative swing, the net voltage is approximately zero, and hence no pulsés are delivered to the plug.

In Figure Fourteen, the impressed voltage is approximately +/- 40 volts at 20 hertz. Both positive and negative swings exceed the suppression voltage, and hence, *virtually no sparks are delivered to the plug*, as can be seen in the lower trace.

Figure Fifteen is a +/- 30 volt, 33 hertz sinewave impressed on the 12 volt bias. In addition to variations in amplitude, this oscillograph shows evidence of desynchronization as the distance between spark plugs signals is nonuniform. In Figure Sixteen, with the sinewave driving the amplifier to its maximum signal levels (+/- 40 volts), causing "clipping," there is again considerable suppression of spark plug signals.

AFTER-EFFECTS

As there are, as of this writing, a few automobiles still on the road with the conventional nonelectronic ignition system, there exists the possibility of validating the theory presented here. This is so because the postulated

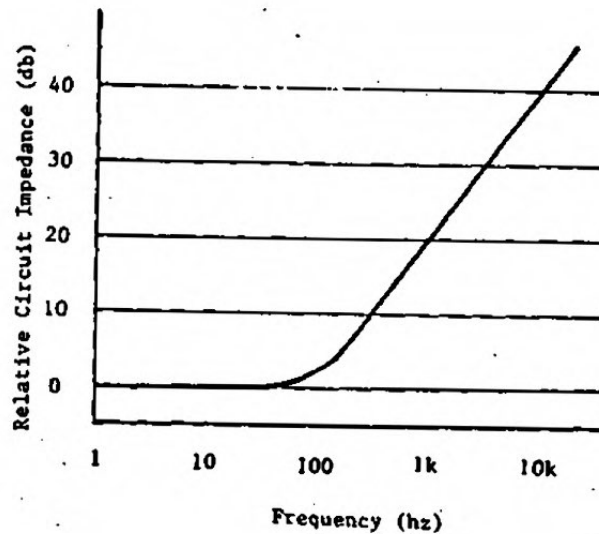

FIGURE ELEVEN - Relative Impedance as a function of Frequency

interference leaves its mark in two ways.

First, there is damage to the points. It usually appears as severe discoloration of both contacts and the arm supporting the contacts, and the presence of a yellow powder between and on the sides of the contacts themselves. Interestingly, this damage does not appear to affect the electrical performance of the ignition system. Thus, unless the points are visually inspected, the damage may go unnoticed.

Second, there is considerable heating of the ignition resistor. This resistor is usually comprised of a resistance wire coiled about a ceramic core, and surrounded by a ceramic form open to one side. One resistor used in this experiment withstood repeated abuse at currents of up to 15 amps over two years of experimentation before failing. During failure, the ceramic shattered and the resistance wire broke. In a VIE case, the ignition resistor should certainly be checked for excessive heating, which usually shows itself by the blue discoloration of the resistance wire.

The coil is comprised of copper wire wound about a soft iron core supported by a porcelain insulator, the entire system immersed in oil in a hermetically sealed container. As such, it has considerable heat capacity that

might limit temperature excursions for brief periods. Over the course of these experiments the coil repeatedly became extremely hot after exposure of up to a minute, yet never with any change in electrical characteristics. No damage was ever observed in the capacitor.

IMPLICATIONS

Having completed the above experiments, I am haunted by the possibility that I have presided over an experimental *reductio ad absurdum*. In mathematics, this is the disposal of a proposition by showing that its logical conclusion is *absurd*.

As shown above, the voltage induced in the low voltage circuit of a representative conventional ignition system must be approximately 40 volts (for square wave excitation) at no more than 100 hertz. If one assumes an effective enclosed area of 1 square meter, the magnetic field at the vehicle must be .1 Tesla, or a *kilogauss!* Fields of this magnitude exist between the poles of a strong magnet, over relatively small volumes. As one gets closer to the interfering source, this field becomes much larger very fast.

The magnetic field about a simple magnet, whether it be a small bar magnet or the earth itself, can usually be modeled as a magnetic dipole. An

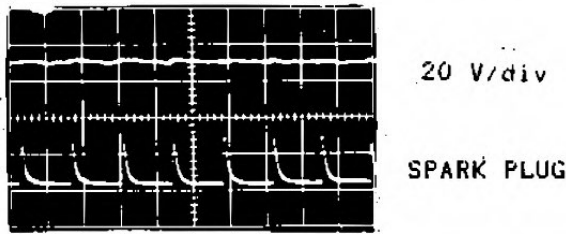

Amplifier Biased Waveforms

FIGURE TWELVE

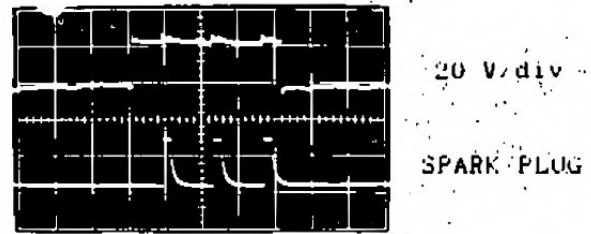

Undervoltage during Squarewave Excitation.

FIGURE THIRTEEN

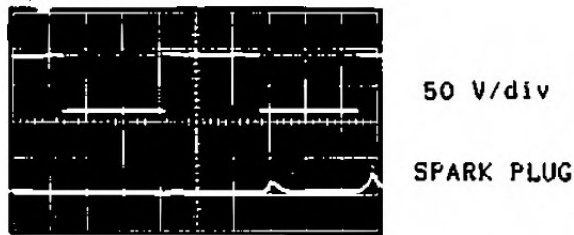

Spark Suppression
during Squarewave Excitation

FIGURE FOURTEEN

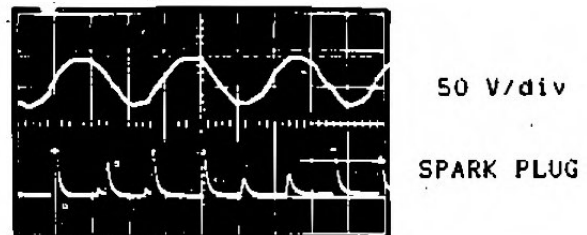

Desynchronization
during Sinewave Excitation

FIGURE FIFTEEN

elementary dipole consists of a ring of area A_R carrying a current I_R , and the strength of the source, the *magnetic moment*, is the product of the two, $I_R A_R$. If one is in the same plane as a dipole, then the field at any point on the plane a distance r from the dipole is:

$$B = \frac{10^{-7} M}{r^3}$$

This equation holds for distances much greater than the radius of the ring.

Since the magnitude of the field, B , is known, the magnetic moment required to produce that field can be calculated for any particular distance. This has been done in Figure Seventeen. For convenience, the distance from the object has been graphed in feet. The dashed lines break the graph into three regions, following the analysis of *Vehicle Interference Effects* done by Donald A. Johnson¹⁵, each region containing approximately equal numbers of cases. The magnetic

moment required to produce spark suppression is seen to vary from as "little" as 3.5×10^9 to values in excess of 2×10^{12} amp-meter². This three order of magnitude range is disconcerting, but there is a possibility of narrowing it down a bit.

Figure Eighteen summarizes Johnson's data, showing the percentage of complete stalls in cases where some engine distress was noted and the distance to the object had been estimated. In "close" cases, under 100 feet, slightly under 90% of the engines stalled completely. In the intermediate region, between 100 and 400 feet, the percentage of complete stalls has fallen to slightly under 80%. Beyond 400 feet, the percentage of stalls has dropped to about 60%. The ignition system used in the laboratory experiments, a standard General Motors 8-cylinder system common to the Levealand era, may be taken to be representative of most systems on the road. As such, one can assume that some systems will be more sensitive to disruption and some will be less. If we assume that our laboratory

system is median, then the "far" region, beyond 400 feet, is the approximate distance at which the interfering field is no longer large enough to produce full spark suppression. This is obviously pretty shaky reasoning, using questionable assumptions and soft data. But it is probably the best we can do under the circumstances and it indicates a most probable magnetic moment in the vicinity of 10^{12} amp-meter².

Two problems occur immediately:

First, there is the matter of survival of the ignition circuit. If full spark suppression is marginal at 400 feet, a system exposed to fields much closer to the object would encounter induced voltages one or two orders of magnitude greater than those produced in the laboratory. In the absence of some mechanism to limit the current (such as the battery perhaps), it is difficult to understand how the ignition could avoid catastrophic damage unless the distances reported in the anecdotal data are systematically exaggerated.

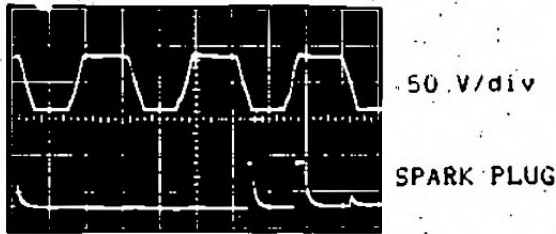

Spark Suppression
during Sinewave Excitation
FIGURE SIXTEEN

Secondly, a magnetic moment of 10^{12} amp-meter² can only be characterized as awesome. In fact, I would regard the existence of such magnetic moments as more incredible than their possible extraterrestrial origin! The magnetic fields in the vicinity of such an object would exceed 100 Tesla. Such fields have been created on earth but only in small volumes (a few cm³) for very short periods of time (a few microseconds)¹⁶.

Is there other evidence that could support such fields and moments? The answer is yes.

For example, the fields required to heat finger rings in CEII¹⁷ cases are almost exactly the same as those required to produce spark suppression. As a result, the magnetic moments of the interfering sources in these cases are similarly absurd.

An interesting case that does not involve magnetic induction per se is the 1947 Johnson Case. This case involved a prospector in the Cascade Mountains who allegedly sighted objects overhead the same day Kenneth Arnold made his famous sighting. When the objects passed overhead at an estimated 1000 feet, a small compass deflected violently. If one assumes that a field of a few gauss would be required to account for the compass behavior, the magnetic moment of the source must have been between 10^{10} and 10^{11} amp-meter². It should be noted that on the basis of this result, the two investigators for USAF Project Sign, G.E. Valley and J. Allen Hynek, discounted the observation. The Sign report (under "AMC Opinion") alleged that "...he colored his report with inference of huge magnetic

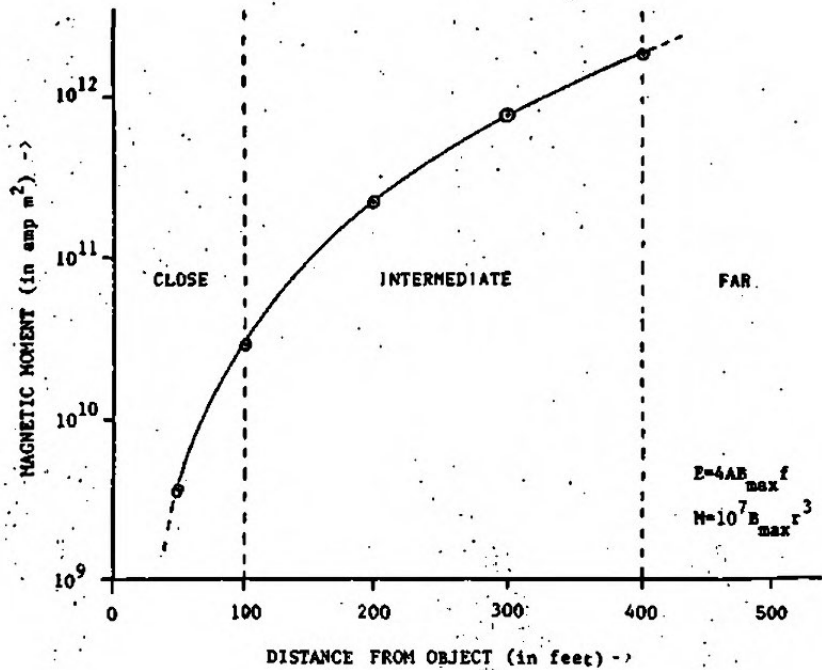

FIGURE SEVENTEEN.

fields, as to the implications of which he was obviously uninformed." (Italics mine.)

In summary, vehicle ignition failure due to induced currents in the low voltage circuit of a conventional ignition system can occur at field strengths and frequencies hypothesized to cause other CEII effects. On the one hand, this tends to lend consistency to the anecdotal data. On the other hand it yields consistently absurd (I hesitate to say unphysical) values of the magnetic moment of the interfering source. Finally I would warn the reader that the experiments reported in this article

show only that a conventional automotive ignition circuit is susceptible to powerful low frequency magnetic fields. If the collected anecdotal evidence involving VIE should not be true and accurate, then this work is of little ufological interest. I am reminded of a tenet of logic — Anything follows from a false premise!

(Editor's note: This significant laboratory experiment is an extension of the work previously published by James M. McCampbell, MUFON Director for Research, Donald A. Johnson, Ph.D., State Director for Washington and others noted in the references.)

© 1986 Joe Kirk Thomas

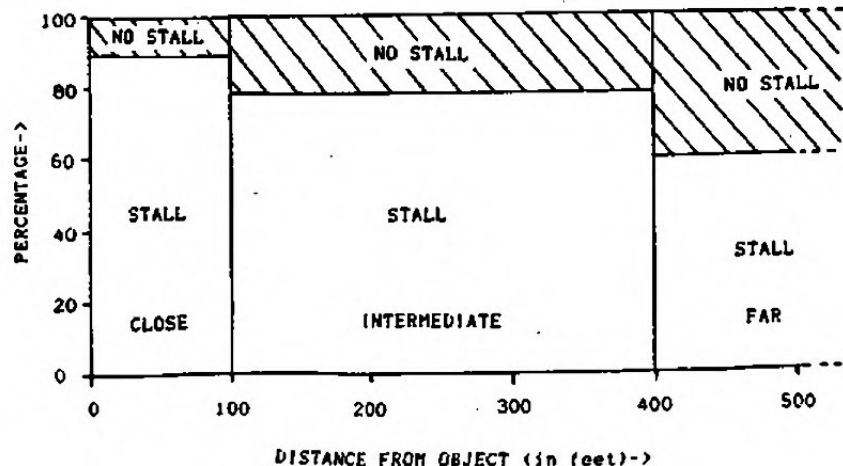

FIGURE EIGHTEEN

REFERENCES AND FOOTNOTES

1. *The UFO Evidence*, edited by Richard H. Hall (Washington, D.C.: National Investigations Committee on Aerial Phenomena, 1964) pp. 73-76.
2. James McCampbell, *UFOLOGY* (Belmont, California: Jaymac Company, 1973) p. 52.
3. James McCampbell, "UFO Interference with Automobile Electrical Systems," in the *Proceedings of the 1976 CUFOS Conference*, edited by Nancy Dornbos (Evanston, Illinois: The Center for UFO Studies, 1976) pp. 178-179.
4. James McCampbell, "Further Evidence of UFO Radiation," *MUFON UFO Symposium Proceedings* (Seguin, Texas: The Mutual UFO Network, 1977) pp. 25-33.
5. E.U. Condon, *Scientific Study of Unidentified Flying Objects*, (New York: Bantam Books, 1969) pp. 100-104.
6. Coral and Jim Lorenzen, *UFOs the Whole Story* (New York: Signet, 1969) p. 146.
7. James McCampbell, "UFO Interference with Vehicles and Self-Starting Engines," *MUFON UFO Symposium Proceedings* (Seguin, Texas: The Mutual UFO Network, 1983) pp. 45-59.
8. Personal Communications, J. Thomas to J. McCampbell, October, 1983.
9. Joe Kirk Thomas, "An Alternative to the Microwave Theory of the Hot Ring Syndrome," *MUFON UFO Journal No. 194* (Seguin, Texas: The Mutual UFO Network, April, 1984) pp. 9-11.
10. Joe Kirk Thomas, "Ruppelt Rings: The Effects of Low Frequency Magnetic Fields," *MUFON UFO Journal No. 197* (Seguin, Texas: The Mutual UFO Network, September, 1984) pp. 5-10.
11. Alan K. Thomas, "Magnetic Shielded Enclosure Design in the D.C. and VLF Region," *IEEE Transactions in Electromagnetic Compatibility*, Vol. EMC-10, No. 1, March 1968, p. 145.
12. *Ibid.*, p. 146.
13. Because the ignition circuit is grounded to the automobile body, multiple loops exist. The induced voltage is proportional to the net area.
14. Since the automobile uses a four-cycle engine, the crankshaft turns twice for each revolution of the cam shaft.
15. Donald A. Johnson, "The Effects of Position and Distance in UFO Ignition-Interference Cases," *The Journal of UFO Studies, Vol. III* (Evanston, Illinois: The Center for UFO Studies, 1982) p.5.
16. A survey article covering recent progress in the generation of very high magnetic fields is Fritz Herlach, "Pulsed Magnetic Field Generators and Their Practical Application," *Megagauss Physics and Technology*, edited by Peter Turchi (New York: Plenum Press, 1980) pp.1-26.
17. Op. Cit., *MUFON UFO Journal No. 194* (Seguin: The Mutual UFO Network, 1983) p. 10.

CONFERENCE UPDATE

By Walter H. Andrus

Walt Andrus is MUFON's international director.

BACKGROUND

At the First London International UFO Congress held in London, England on August 26 and 27, 1979, the Provisional International Committee for UFO Research (PICUR) was organized, reflecting the spirit of cooperation among nations in understanding the UFO phenomenon. Subsequent meetings have been held in conjunction with the International UFO Congresses in 1981, 1983, and 1987. As the organization grew in stature the "provisional" title was dropped when a Constitution was adopted at the founding meeting of the International Committee for UFO Research (ICUR) August 26-29, 1983. A membership fee was established based upon the number of members in each organization.

In 1981, Dr. J. Allen Hynek was elected President Emeritus of PICUR/ICUR. Peter Hill (BUFORA, Scotland) chaired the committee from its inception in 1979 until officers were elected in 1983. The following officers for ICUR were elected in 1983: Bertil Kuhlemann (Project URD/Sweden),

chairman; Bjarne Hakansson (Project URD/Sweden), Secretary; and Robert S. Digby (BUFORA/England) Treasurer. As a founding member, MUFON has been represented at all meetings through 1983 by Dr. Michael Sinclair, International Coordinator. Dr. J. Allen Hynek (CUFOS/USA) participated in each meeting from 1979 through 1983.

The two major projects adopted by the committee for action at the 1983 meeting were (1) Worldwide standards should be adopted in areas of terminology, investigation, data processing, communication, and (2) A scientific standard reference textbook should be compiled covering such areas as data, methods and the technical aspects. It was also recommended that report abstracts should be added in English when reports originated outside English speaking countries. Robert S. Digby was elected the responsible person for the "World Wide Standards" project and Stanton T. Friedman was responsible for the "Scientific Standard Reference Textbook" project. This brings us up to 1987.

INFORMAL ICUR MEETING IN WASHINGTON, D.C.

On June 26, 1987, an informal ICUR meeting, chaired by Bertil Kuhlemann (Sweden), was held in Washington, D.C. in conjunction with the MUFON 1987 International UFO Symposium. Attendees were Hilary Evans (England), Vincente-Juan Ballester Olmos (Spain), J. Antonio Huneus (representing Chile), Daniel A Perisse (Argentina), Dr. Willy Smith, (representing Brazil, Uruguay and Project UNICAT), Cynthia Hind (Africa), Dr. Roberto Pinotti (Italy), Jean-Jacque Velasco (GEPAN/France), Paul Norman (Australia), Cynthia Newby-Luce (Brazil) and Walt Andrus (MUFON). Dr. Richard F. Haines was a contributing observer. The status of the projects assigned to Robert Digby and Stanton Friedman were reviewed as well as the organizations who have currently paid their annual membership fee. It was announced that the World Ufologists Association (WUA), an association of international Ufologists, has been disbanded.

ICUR MEETING IN LONDON ON JULY 9, 1987

The enthusiasm generated in

Washington, D.C. for the work of the International Committee for UFO Research and the need to solve common problems on a worldwide scale was evident by the attendees even though small in numbers. Bertil Kuhlemann (Project URD/Sweden) chaired the meeting, attended by Stephen Gamble (BUFORA/England), William P. Heinzerling (MUFON/U.S.A.), Robert S. Digby (BUFORA/England), Dr. Willy Smith (Project UNICAT/U.S.A.), Mike Wooten (BUFORA/England), Arnold West, President of the British UFO Research Association, and Walt Andrus (MUFON/U.S.A.)

Projects assigned to Stanton T. Friedman and Robert S. Digby at the 1983 meeting were reviewed, indicating that only a limited amount of work had been accomplished in fulfilling the two major objectives. Shortly after receiving his assignment Mr. Digby transferred to a new job in Saudi Arabia, thus complicating his communications with his committee in Europe. No response has been received on the status of the Textbook on UFO Research project assigned to Mr. Friedman after 4 years.

It was mutually agreed that a worldwide standard UFO terminology was still a priority item. Since a number of the member organizations have published very fine manuals for field investigators, the consensus of the group was to emphasize the techniques and procedures presently being used instead of writing and publishing a Textbook for UFO Research at this time. It is conceivable that a textbook by ICUR could be done commercially following the two books being published by BUFORA in 1987 and 1988. Bertil Kuhlemann suggested that such a book could be created on a computer to reduce costs.

A discussion ensued on UFO news media exposure throughout the world. Scandinavians have been shielded from international UFO sightings such as Brazil (May 19, 1986) and the Japan Air Lines Case (November 17, 1986). This fact posed the question "what can we do as an international committee to break into the international press?"

The necessity of building and operating computerized UFO sighting

files was weighed, comparing existing files such as UFOCAT, UNICAT, GEPAN and Project URD systems. No decision was reached upon an internationally acceptable system. It was agreed that UFOCAT, as developed by Dr. David Saunders was a pioneer in computerization, however it is obsolete for all practical purposes. Project URD has considerable confidence in their system. MUFON advised that it will utilize UNICAT operated by Dr. Willy Smith.

In order to communicate the work being done by ICUR and to solicit new member organizations throughout the world, both the BUFORA BULLETIN and the MUFON UFO JOURNAL will publish articles submitted by ICUR officers. This particular article inaugurates this new international policy.

The UNICAT Project applied for membership and was accepted by ICUR as a member organization. Walt Andrus will contact and invite CUFOS, FUFOR and CAUS in the United States to join ICUR. Bertil Kuhlemann will contact SIFORT in Sweden. Letters of invitation will be mailed to all UFO organizations listed in the new book titled *UFOs 1947-1987* edited by Hilary Evans and John Spencer.

New officers were elected for a two year term for ICUR as reported in the August issue of the MUFON UFO Journal. They were: Chairman, Robert S. Digby; Vice Chairman, Walter H. Andrus Jr.; Secretary, Stephen J. Gamble; and Treasurer, John L. Spencer. A treasurers report was read relating the balance in British Sterling Pounds, Swedish Crowns and U.S. Dollars.

Considerable time was devoted to "brainstorming" potential future goals and objectives for ICUR. It was clearly stated and agreed that ICUR is organized to help all UFO organizations throughout the world by providing cooperative services and communications. It is simply an umbrella organization encompassing the world for greater cooperation. When selecting goals and objectives, none will usurp or replace the organizational structure of existing UFO organizations. One of the goals, obviously, is to promote scientific

respectability for Ufology worldwide among the member organizations. Other proposed goals concerned a UFO data base, Field Investigator's Manuals, UFO sighting report forms, investigator training, media interaction, and statistical analysis.

The immediate objectives selected were (1) support future International UFO Congresses (2) Specialization lists for people researching the same fields of interest and (3) an ICUR letterhead with a futuristic and leadership motif. The most newsworthy project to be announced is that the ICUR Committee voted to sponsor and support "The 5th International UFO Congress" to be held at the London Business School in 1989, through its member organizations. BUFORA will be the host organization, since the London location is the most convenient for the majority of European UFO organizations. As Vice Chairman of ICUR, I am making plans to attend the 1989 meeting. As the number of member organizations increase, the attendance will also grow.

This is an open invitation to all interested UFO organizations worldwide to join ICUR. For information on how to become a member please write to either the Chairman or Vice Chairman at the following addresses: Robert S. Digby, 55 Hayling Ave., Little Paxton, Huntingdon, Cambridgeshire PE19 4 HG, England or Walter H. Andrus, Jr., 103 Oldtowne Road, Seguin, Texas 78155-4099, U.S.A.

**40 YEARS
IS LONG
ENOUGH**

Fund for **UFO** Research

NEWS'N'VIEWS

WHO'S WHO? DIRECTORY

The first edition of the *Annual UFO Phenomenon Who's Who* is presently being compiled. Literally hundreds of active participants involved in the study of the UFO enigma are being contacted in over twenty countries throughout the world.

Individuals and organizations are being asked to furnish names and addresses of active people involved in the UFO phenomenon community either directly or by making announcements in various publications or newsletters.

The benefits of the *Who's Who* directory are many and far-reaching. The various scattered groups of people throughout the world will have a means of establishing and maintaining contact with one another because the publication will be updated annually. This project, if successful, will contribute greatly to a more unified UFO phenomenon community, worldwide. Investigation assignments and research projects will become more accessible and efficient. The directory will demonstrate the existence of an international community studying a worldwide phenomenon.

I look forward to any assistance that you or your organization may be able to offer. An extended deadline has been set for December 31, 1987.

For more information, please write Robert D. Boyd, Box 66404, Mobile, Alabama, 36606.

MUFON AMATEUR RADIO NET

From Reading, Massachusetts to Grove, Oklahoma, the Carolinas to Kansas: "Calling the MUFON Amateur Radio Net" is the friendly summons emanating from radio speakers.

What is the MUFON Net and what is its purpose? These questions are asked by curious radio operators overhearing our call and the ensuing conversations.

The MUFON net is a group of dedicated radio amateur operators who gather weekly on a shortwave radio frequency of 7237 KHZ lower sideband (LSB), to exchange information about UFOs and related phenomenon.

The purpose of the net is to allow timely distribution of UFO reports on a nationwide basis. As we all know the news media allocates very little coverage to this interesting subject. The intent of this net is to allow knowledge obtainable in one section of the country to be shared with other areas not fortunate to have the information available.

One of the problems of the network is the large lack of input from stations west of the central time zone. The net control stations appreciate the large time differential and do not expect these stations to be up on a Saturday morning at 5 or 6 AM their time. We would be interested in knowing if the western stations would be willing to form a west coast network and a possible weekly tie in to the eastern net. This, we feel, would allow an expedient flow of information summaries between interested persons without relying on delayed reports via the mail or magazine.

One benefit would befall the non-licensed field investigators in that experienced radio communications personnel would be available to assist in communications from remote siteing areas. These communications personnel would also be able to note any anomalies in radio propagation which may occur during a UFO flap, thus adding to our base knowledge of this subject.

An additional use of the stations and nets could be the possible tie-in

with local VHF networks. This would allow non H.F. licensed stations to relay information into the national UFO traffic network.

If you are interested in forming a western net or have any additional comments or questions please feel free to contact me at the following address: Ms. Leslie Varnicle WA3QLW, 5 Hillcrest Circle, Etters, Pa. 17319-9709.

FUND FOR UFO RESEARCH QUARTERLY REPORT April - June 1987

The highlight of this quarter was the "International Symposium on Unidentified Aerial Phenomena; 1947-1987...A World View," held June 26-28 at the American University in Washington, D.C. This year's annual MUFON symposium, hosted by the Fund, took place during the 40th anniversary of the modern UFO era. Several major events took place during the week of the Symposium:

On June 24, ABC's "Nightline" featured an overview of the 40-year history of UFOs (including an interview with the Fund's Chairman, Dr. Bruce Maccabee) and a debate between nuclear physicist Stanton Friedman and aviation writer Philip Klass. A focus of discussion was the recent release by investigators Bill Moore, Jaime Shandera and Friedman of what appears to be a top secret document prepared for President-elect Eisenhower on "MJ TWLEVE," a special group charged with investigating the crash and retrieval of alien hardware and bodies near Roswell, New Mexico, in 1947. (The documents and supporting information are available from the Fund; see the enclosed reply form.) The "Nightline" interview was initiated by Larry Koss.

On June 25, a special briefing for the foreign press was conducted at the Foreign Press Office of the U.S.

Information Agency. Participants were Dr. Maccabee, Shandera, Budd Hopkins and Koss. Also present were Symposium speakers from Argentina, Canada, England, Italy and Zimbabwe. About 50 members of the foreign press corps attended. A videotaped record of the briefing was made and is available from the Fund.

On June 26, Dr. Maccabee presented a briefing on the history of UFOs for Members of Congress and their staffs — the first such briefing on Capitol Hill in nearly 20 years. Approximately 40 representatives of congressional offices attended.

Later that day, a large number of media representatives came to a major news conference to publicize the Symposium at the American University. On stage were Dr. Maccabee, Bill Moore, Stanton Friedman and Budd Hopkins.

The Symposium officially began Saturday morning, with opening remarks by Walt Andrus, MUFON International Director, and Dr. Maccabee. Presentations by the International Speakers followed. (The Symposium Proceedings are available from MUFON, 103 Oldtowne Road, Seguin, TX 78155, for \$15.00 plus \$1.50 postage.)

In the afternoon, a number of attendees presented contributed papers on a wide variety of aspects of the UFO subject. This was the first UFO symposium to have contributed papers, which are common features at meetings of major scientific organizations. (Abstracts of the papers are available from the Fund, along with a complete contributed paper by Dr. Willy Smith and two major papers which were received too late to be included in the Proceedings (Stanton Friedman on ufology in Canada and Vicente-Juan Ballester-Olmos on ufology in Spain).)

Those who attended the Banquet on Saturday night heard a riveting talk by Bill Moore, who revealed for the first time how he has established a connection with an "inside source" who has supplied some valuable UFO documents, including the "MJ TWELVE" document mentioned earlier.

Following the Banquet, there were

two panel discussions on abduction cases: one consisting of investigators of such cases, the other of individuals who report having been abducted.

The panel of "abductologists," chaired by Dr. Michael Swords, included Budd Hopkins, Dr. David Jacobs and Dr. Eddie Bullard, author of a comprehensive catalog of abduction cases. (Dr. Bullard's entire study — and a summary version — are available from the Fund.) As a result of his work, the Fund presented Dr. Bullard a special "Award for Scientific Achievement," including a check for \$500.

The panel of "abductees," chaired by Dr. Jacobs, included Whitley Strieber (author of the best-seller, *Communion*), "Kathie Davis," (the principal subject of Budd Hopkins' latest book, *Intruders*), and a number of other individuals who agreed to speak publicly about their experiences. For many of the 500 attendees, this panel discussion was the highlight of the Symposium.

(Incidentally, a special videotaped program, *MUFON Symposium Highlights*, is being produced exclusively for the Fund by a professional TV producer and will be available in the near future; advance orders are now being taken. The program will include highlights of the panel discussions.)

The remaining International Speakers and contributed papers were presented on Sunday. A highlight of the day was the panel on government responses to the UFO question. Featured were: Bill Moore, Stanton Friedman, Barry Greenwood, Bill Chalker of Australia, Jenny Randles of England, Jenny Zeidman (a close colleague of the late Dr. J. Allen Hynek), and Dr. Maccabee. (Jenny Randles' latest book, *The UFO Conspiracy*, is available from the Fund, as well as audio tapes of the Sunday speakers and the government panel discussion.)

Despite some problems with the facilities, the Symposium was a huge success. The bold attempt to pay travel expenses for speakers from all parts of the world was unprecedented in the UFO field, but it, too, was successful — thanks to the generous donations of the

Fund's contributors.

The Fund for UFO Research has only two sources of income to support its activities: contributions and sales of documents and other educational materials. Contributions to the Fund are 100% tax deductible; the price of documents is 50% tax deductible.

If we are to take advantage of the resurgence of interest in the UFO phenomenon, we need to raise a substantial amount of money in the near future. All contributors of \$10 or more will receive a special "I Support UFO Research" button which was specially designed for the Symposium with our rallying cry: "Forty Years Is Long Enough!" If you are committed to solving the UFO mystery, we know you will wear your button proudly. As they say in the commercial: "We thank you for your support."

UFO NEWSCLIPPING SERVICE

The UFO NEWSCLIPPING SERVICE will keep you informed of all the latest United States and World-Wide UFO activity, as it happens! Our service was started in 1969, at which time we contracted with a reputable international newspaper-clipping bureau to obtain for us, those hard to find UFO reports (i.e., little known photographic cases, close encounter and landing reports, occupant cases) and all other UFO reports, many of which are carried only in small town or foreign newspapers.

"Our UFO Newsclipping Service issues are 20-page monthly reports, reproduced by photo-offset, containing the latest United States and Canadian UFO newsclippings, with our foreign section carrying the latest British, Australian, New Zealand and other foreign press reports. Also included is a 3-5 page section of "Fortean" clippings (i.e. Bigfoot and other "monster" reports). Let us keep you informed of the latest happenings in the UFO and Fortean fields."

For subscription information and sample pages from our service, write today to:

UFO NEWSCLIPPING SERVICE
Route 1 — Box 220
Plumerville, Arkansas 72127

MENZEL MYSTERY

By Walter H. Andrus

When the late Dr. Donald Menzel's name appeared as a member of the Majestic-12 Group on the controversial MJ-12 documents, it was not only revealing, but produced an unexpected contradiction to his apparent philosophy on flying saucers. The second paragraph of page 004 makes the following statement:

"Since it is virtually certain that these craft do not originate in any country on earth, considerable speculation has centered around what their point of origin might be and how they get here. Mars was and remains a possibility, although some scientists, most notably Dr. Menzel, consider it more likely that we are dealing with beings from another solar system entirely."

If this statement can be attributed to an actual quotation and is the professional opinion of Dr. Donald H. Menzel with regard to UFOs, it is in direct contrast to the position he subsequently took in writing his books: *Flying Saucers*, (1953) Harvard University Press; *The World of Flying Saucers* (1963) co-authored with Mrs. Lyle G. Boyd; and *The UFO Enigma* (1977) co-authored with Dr. Ernest H. Taves.

One of the implications suggested by a radical departure from the "extra-terrestrial hypothesis" to that of a scientific skeptic or "debunker" in his writings is that he had a job assigned to him as a member of the Majestic-12 Group. Was Dr. Menzel wearing "two hats" and playing dual roles in this intriguing mystery? Why was he so motivated to write three books "explaining away" the UFO phenomenon? These are questions that have become more difficult to answer since all twelve members of the MJ-12 committee are now deceased.

CONSISTENT?

We have been asking ourselves the



Harvard Astronomer Dr. Donald H. Menzel

big question — are the MJ-12 documents internally consistent, regarding known and possible activities of these twelve outstanding men of 40 years ago? Robert H. Bletchman has been speculating upon the author of the documents to help determine their authenticity. Since Admiral Roscoe H. Hillenkoetter's name heads the list and knowing his later affiliation with the National Investigations Committee on Aerial Phenomena (NICAP) as a member of the Board of Governors, Mr. Bletchman has been collecting unrelated memos written by Admiral Hillenkoetter in order to perform a language comparison analysis. He is seeking qualified people capable of executing a comparative analysis of these memos to study the language style of Admiral Hillenkoetter.

Like many of his fellow researchers, the authenticity of the MJ-12 papers piqued the agnostic philosophy of James W. Moseley, editor of the non-scheduled newsletter, *Saucer Smear*. Of the twelve men, the

most intriguing to Jim was Dr. Donald H. Menzel, an astronomer and astrophysicist, and former Director of the Harvard College Observatory. Dr. Menzel was, ufologically speaking, the Philip Klass of his day. Since all 12 members are deceased, Mr. Moseley noted that Dr. Menzel's latest book, *The UFO Enigma* was co-authored with Dr. Ernest H. Taves, a wealthy retired psychiatrist, and an active member of CSICOP.

James Moseley mailed copies of the MJ-12 documents to Dr. Taves with a letter requesting his opinion on the MJ-12 papers and the position of Dr. Menzel with regard to his possible dual role as a member of the MJ-12 group. Dr. Taves worked very closely with Menzel and still is close friends with Menzel's widow and his private secretary, with whom he consulted upon receipt of the MJ-12 material. Mr. Moseley has shared the contents of his letter from Dr. Taves responding to his questions (slightly abbreviated because of space limitations), Dr. Ernest H. Taves

replied in the following manner:

TAVES LETTER

"I am informed that at the recent MUFON Conference Stanton Friedman contributed a paper entitled "The Double Life of Donald H. Menzel." This was preceded by widespread distribution, by the "Moore-Shandera-Friedman Research Project into U.S. Government UFO Policy" (hereafter MSF), of "New UFO Documents." It has been incumbent upon me to respond.

"First, with respect to the alleged Top Secret document, MSF states they cannot endorse the authenticity of the document. I state that I can, in my opinion, endorse the fraudulence of the document. MSF asks, "Hoax or proof of alien visitation?" I respond, "Hoax." As for the document itself: The version that I have seen (apparently a number of versions exist, differing in which text has been blacked out) clearly has not been officially declassified. If the document is genuine, and has not been declassified, one wonders whether MSF might not be in trouble with the FBI, but that is no concern of mine....

"As for the comments and questions (by Moore) with respect to Donald Menzel, none of them have any bearing upon his alleged membership in the "Majestic 12" group. MSF has apparently examined Menzel's correspondence and his autobiography, both of which are to be found in the Harvard Archives in Cambridge, and has used this information in aid of making a case suggesting Menzel's participation in a government coverup of a crash-landed UFO.

In this overreaching attempt MSF states, for example, that Menzel wrote to John F. Kennedy about such matters. Of course Professor Menzel wrote to John F. Kennedy about such matters... He and Kennedy had been friends for a long time, and Menzel foresaw that when Kennedy became president, he might wish to consult him about scientific matters. Menzel wanted Kennedy to know about his history in sensitive areas. And Kennedy did, indeed, consult Menzel on a number of scientific matters, seeking his advice. It was certainly no secret to

the Harvard community that Menzel had done much classified work for the government over a period of decades. The other points MSF raises are similarly noncontributory to "Majestic 12."

"I shall try now to add some information about Menzel that does relate to his alleged participation in a UFO coverup. Donald Menzel, during the latter years of his life, was my closest friend and associate, and I was co-author with him on his last UFO book, *The UFO Enigma*. During the last year of his life we spent many, many hours working on the book, and during the course of these discussions we explored, together, any number of related fields including the writing of science fiction (a field in which we had both published), the exploration of space, the probability of the existence of extraterrestrial intelligence, and so on. I can surely say that — with respect to Donald's thinking about such matters — I knew his mind and thinking more intimately than anyone else could have. In addition I knew what kind of a man he was. And I state categorically that he would have repudiated with contempt any suggestion that he participated in the coverup proposed in the alleged secret document.

"If an alien spaceship had crashed, if bodies of aliens had been recovered, Donald would certainly have been one of the first to be called to participate in an investigation. He would have welcomed this with the greatest enthusiasm. If national security were involved — which some might have thought to be the case for several months or a year or so — Donald would have gone along with that. But as it became clear — as indeed it has, over the years — that if this incident had happened it had no bearing upon national security, he would have been unable to continue to participate in a misguided and unnecessary cover-up. His interests lay in the discovery and propagation of scientific knowledge.

"Above all, he would have been utterly incapable of the intellectual dishonesty of writing books debunking UFOs while knowing full well that an alien spacecraft bearing alien occupants had crashed in New Mexico. The insinuations in the MSF

documents are a profound disservice to the memory of Donald Menzel." (End of Taves statement.)

Jim Moseley must be commended for taking the initiative of exploring the relationship of Dr. Donald Menzel to the alleged MJ-12 Group and the apparent discrepancy between the document statement and Dr. Menzel's books. Even though Dr. Taves is a member of the Committee for the Scientific Investigation of Claims of the Paranormal (CSICOP), known for their extreme debunking tactics, his personal evaluation of Dr. Menzel is valuable in the quest for answers to the authenticity of the MJ-12 papers. Dr. Taves' response letter indicates that he may have discussed this matter with Philip Klass when he said "one wonders whether MSF might not be in trouble with the FBI, but that is no concern of mine..."

The MUFON UFO Journal will continue to publish pertinent information both pro and con on the credibility of the MJ-12 documents, until there is no longer a "smoking gun" involved. It is imperative that the facts are disclosed to the UFO community, the news media, and the public.

(See over for the National Archives' response to requests for MJ-12 documents.)

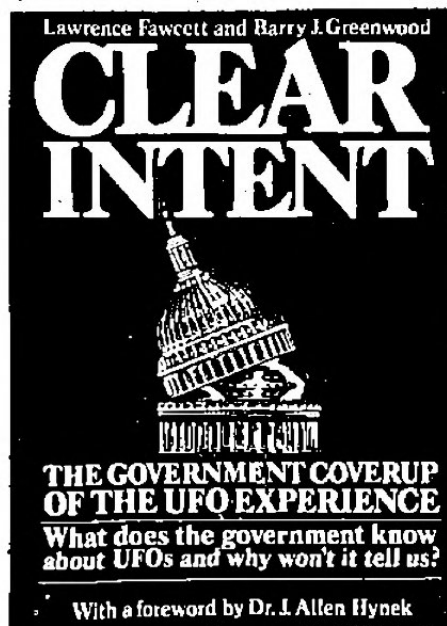

National Archives



Washington, DC 20408

3 AUG 1987

Mr. Billy Cox
Staff Writer
Florida Today
USA Today
Cape Publications, Inc.
P.O. Box 363000
Melbourne, FL 32936

Dear Mr. Cox:

This is in response to your letter dated June 30, 1987, to the President concerning the authenticity of documents concerning "MJ-12".

The National Archives and Records Administration makes Federal records and donated historical materials available for public research. We do not ordinarily verify nor authenticate every document or the information contained therein.

The National Archives has, however, received many requests concerning "MJ-12". I am enclosing a copy of a reference report we prepared on this subject for your information.

Sincerely,

TRUDY HUSKAMY PETERSON
Assistant Archivist
for the National Archives
(202) 523-3130

Enclosure

National Archives and Records Administration

National Archives



Washington, DC 20408

Date : July 22, 1987

Reply to
Attn of : Military Reference Branch

Subject : Reference Report on MJ-12

To : The Record

The National Archives has received many requests for documentation and information about "Project MJ-12". Many of the inquiries concern a memorandum from Robert Cutler to General Nathan Twining, dated July 14, 1954. This particular document poses problems for the following reasons:

1. The document was located in Record Group 341, entry 267. The series is filed by a Top Secret register number. This document does not bear such a number.
2. The document is filed in the folder T4-1846. There are no other documents in the folder regarding "NSC/MJ-12".
3. The Military Reference Branch (Edward Reese) has conducted a search in the records of the Secretary of Defense, the Joint Chiefs of Staff, Headquarters US Air Force, and in other related files. No further information has been found on this subject.
4. Inquiries to the US Air Force, the Joint Chiefs of Staff, and the National Security Council failed to produce further information.
5. The Acting Director of the Freedom of Information Office of the National Security Council informed us that "Top Secret Restricted Information" is a marking which did not come into use at the National Security Council until the Nixon Administration. The Eisenhower Presidential Library also confirms that this particular marking was not used during the Eisenhower Administration.
6. The document in question does not bear an official government letterhead or watermark. The NARA conservation

National Archives and Records Administration

specialist (Mary Ritzenthaler) examined the paper and determined it was a ribbon copy prepared on "dictation onionskin". The Eisenhower Library has examined its collection of the Cutler papers. All documents created by Mr. Cutler while he served on the NSC staff have an eagle watermark in the onionskin carbon paper. Most documents sent out by the NSC were prepared on White House letterhead paper. For the brief period when Mr. Cutler left the NSC, his carbon copies were prepared on "prestige onion-skin".

7. The Judicial, Fiscal, and Social Branch searched the Official Meeting Minute Files of the National Security Council and found no record of a NSC meeting on July 16, 1954. A search of all NSC Meeting Minutes for July 1954 found no mention of MJ-12 nor Majestic.

8. The Judicial, Fiscal, and Social Branch (Mary Ronan) searched the indices of the NSC records and found no listing for: MJ-12, Majestic, unidentified flying objects, UFO, flying saucers, or flying discs.

9. The Judicial, Fiscal, and Social Branch (Mary Ronan) found a memo in a folder titled "Special Meeting July 16, 1954" which indicated that NSC members would be called to a civil defense exercise on July 16, 1954.

10. The Eisenhower Library states, in a letter to NNMR, dated July 16, 1987:

"President Eisenhower's Appointment Books contain no entry for a special meeting on July 16, 1954 which might have included a briefing on MJ-12. Even when the President had 'off the record' meetings, the Appointment Books contain entries indicating the time of the meeting and the participants...

The Declassification Office of the National Security Council has informed us that it has no record of any declassification action having been taken on this memorandum or any other documents on this alleged project...

Robert Cutler, at the direction of President Eisenhower, was visiting overseas military installations on the day he supposedly

3.

issued this memorandum --- July 14, 1954. The Administration Series in Eisenhower's Papers as President contains Cutler's memorandum and report to the President upon his return from the trip. The memorandum is dated July 20, 1954 and refers to Cutler's visits to installations in Europe and North Africa between July 3 and 15. Also, within the NSC Staff Papers is a memorandum dated July 3, 1954, from Cutler to his two subordinates, James S. Lay and J. Patrick Coyne, explaining how they should handle NSC administrative matters during his absence; one would assume that if the memorandum to Twining were genuine, Lay or Coyne would have signed it."

JO ANN WILLIAMSON
JO ANN WILLIAMSON
Chief, Military Reference Branch
Military Archives Division

LOOKING BACK

By Bob Gribble

FORTY YEARS AGO - September 1947: On the 23rd, Lt. General Nathan F. Twining, head of the Army Air Force Material Command, wrote his now famous letter to the commanding general of the Army Air Force, listing the AMC findings on their flying disc investigations. In a classified letter he stated that: The phenomenon reported is something real and not visionary or fictitious; There are objects probably approximating the shape of a disc; of such appreciable size as to appear to be as large as man-made aircraft; Are controlled either manually, automatically, or remotely; Are metallic or light reflecting surface; Are circular or elliptical in shape, flat on bottom and domed on top. That letter was written only 90 days after the Kenneth Arnold sighting.

* * *

THIRTY-FIVE YEARS AGO - September 1952: A large cigar-shaped craft was sighted over Denmark on the 29th. Flying beneath it were several disc-shaped craft, all of them rotating at high speed. Both the large carrier and its satellites were reported from many areas of the country.

* * *

THIRTY YEARS AGO - September 1957: North London, England residents observed a cigar-shaped, blue-green craft moving rapidly over the city during the early AM hours of the 18th. An Air Ministry official said three out of four descriptions of the luminous object were exactly the same. That afternoon Neil McNenam, of Ipplepan, England, observed a large, silver elliptically-shaped object moving at a high rate of speed and glittering in the sunlight. He said it was 80 to 100 feet in diameter. McNenam was an ex-Royal Air Force mechanic. On the night of the 19th, three crew members of a B-47 flying over Texas watched in amazement as a glowing light, "as big as a barn," maneuvered around their

aircraft. With permission from ground control, the pilot dived at the "target." Before the bomber could close on the object it swiftly disappeared, visually and from the radar scopes. That same night, the director of a Grenoble, France, engineering firm and four of his staff said they watched five flying discs hovering over the French Alps for eight minutes. They heard a noise like that of a jet plane, and five black rotating objects — "like dead leaves in the autumn" came into view. They performed a series of aerobatics and a white object, resembling a parachute, emerged from one. Then they shot away at supersonic speed towards the Swiss border. The engineers said they were convinced the objects were not jet aircraft, helicopters or balloons, as their work brought them into frequent contact with these.

* * * *

TWENTY-FIVE YEARS AGO - September 1962: On the night of the 14th, Walter M. Schirra, Jr., America's six-orbit space hero, arrived at Oradell, New Jersey to the cheers of his native state. The astronaut left Oradell in 1942. The following day he received the city's official welcome home, complete with a parade and the dedication of a park in his honor. That night three boys told Oradell police they saw a UFO land in the Oradell reservoir at 7:55 PM. The boys said the object hovered over the water just south of the dam near Oradell Avenue. The UFO landed, then took off silently and at a great rate of speed. The boys said that the only sound that they heard was a loud splash when the object hit the water. (Note: On Schirra's return to planet Earth, his capsule splashed down in the Pacific Ocean.)

Haworth police said they located a man who was working near the Haworth side of the reservoir about 8 PM. They said the man told them he heard a large splash about that time. Police said the boys appeared frightened. They reported pointing out the object to a fisherman who ran as soon as he saw it. The boys described the object as oval-shaped with a band around the middle and spots on the upper half. Within 24-hours, five additional witnesses reported to police that they had witnessed the landing.

TWENTY YEARS AGO - September 1967: On the 10th, the three man crew of a DC-6 airliner flying at 16,000 feet near the Pyrenees mountains — 80 miles northwest of Barcelona, Spain — watched a cone-shaped object fly across their path at supersonic speed about 40 miles ahead. Then the craft slowed, changed direction, and zoomed toward the airliner. It passed half a mile beneath their plane before disappearing. "It was fantastic — I saw the object for three minutes and it was like nothing I had seen before," said Captain Fred Underhill, who had 26 years flying experience. First Officer Patrick Hope, 25, who sketched the object on a pad while it was in sight, said: "It was about 100 feet high and 80 feet wide, and shaped something like an ice cream cone pointed upward. It was apparently made of silvery metal. The top pointed part was quite clear, but below that it was an indistinct shape lost in some sort of haze." The sun was shining on one side of the craft.

Captain Underhill said: "I estimate that in the first minute I watched, the object must have traveled about 60 miles. This puts its speed at about 3500 miles per hour, faster than any aircraft I have ever seen before. It was not revolving. There was no sign of portholes, doors, or even a vapor trail." Flight Engineer Brian Dunlop, 28, who had clocked about 2500 flying hours, said: "The shape drawn by Hope is accurate. If it had been flying with the point forward, it would have been a good aerodynamic shape, but flying with the point upward goes against any known design."

* * *

FIFTEEN YEARS AGO - September 1972: A family of three said a fiery object the size of a house paced their car south of Burlington, Colorado for two miles then landed near their home about 9:30 PM on the 13th. "It stayed with us for two miles for about three or four minutes," said Mrs. Ludwig. "Then it veered over us going southwest into the field. We could see it was the size of a house. It got so bright it was almost like the field was on fire. Then it shot straight up into the sky and appeared as big as the moon. Then it came down again, this time landing in a field about a half mile southwest of our house. It lit

up the field." Mrs. Ludwig explained that the object moved so fast when it shot into the sky and when it plunged back down that she couldn't actually see it move. It was on the ground one instant and in the sky the next.

* * *

TEN YEARS AGO - September 1977: A veteran Continental Airlines captain and his flight deck crew said they saw a huge, lighted UFO overtake their DC-10 east of El Paso, Texas, then accelerate away at blinding speed in the predawn darkness of the 22nd. "If there weren't beings of some kind in it, then certainly someone was controlling it," said Captain George Didlake, 52, a Continental pilot for 21 years. "There is no doubt that its flight movements were preplanned and deliberate — they knew what they were doing. Through my copilots window I could see a row of cabin lights — it appeared to be elongated. Then his speed picked up so drastically, he appeared to jump...it was like watching one of those fast zoom-out tricks they do on TV." Didlake estimated the object to be 300 to 400 feet long — twice as long as a DC-10. First Officer Jack Forsythe, 41, copilot on the flight, remembered: "As I turned around, it looked like lights from an airplane that was passing us — which was impossible in that air corridor at that time."

As second officer Russ Goodenough, 38, the flight engineer, crouched forward in the cockpit to get a glimpse, the object was already through the clouds. It made a sudden 90-degree turn and soared up into the heavens at dazzling speed. Goodenough, who is a former jet fighter pilot, was awed by what he saw. "The thing went suddenly vertical. It was not an aircraft, nor was it a satellite. I wrote in my log book, 'Saw UFO on climb out of El Paso...estimated speed 4000 to 5000 MPH.'" All radar facilities in the area reported no missiles fired and no UFO activity whatsoever at the time of the sighting. But Captain Didlake suggests the UFO was so advanced it may have avoided electronic detection. "I feel that to anyone from another solar system, radar is probably like a birchbark canoe is to us."

LETTERS

Dear Editor,

One aim of the UNICAT Project is to eliminate as much as possible from the records that myriad of dubious events masquerading as UFOs and thus create a data base containing only well-investigated, high-quality cases. This has proven to be an arduous task, as many IFOs in the literature are used again and again as examples of different features of the phenomenon, simply because they have been somehow associated in the past with the name of a well-known researcher. It is obvious that all conclusions based on faulty data cannot be anything but erroneous, and I hope this justifies my being overzealous in pointing out false cases when — with the resources of UNICAT at my disposal — I realize they have been invoked once more.

This critique is not addressed to the writer who uses the references, but to the authors of original books who were negligent in checking their sources and started a chain of misquotations. I strongly believe that the lack of progress in ufological research during the last forty years can be at least partially ascribed to this quagmire of cases without scientific value that permeate the literature and effectively hide the true aspects of the phenomenon.

In the paper entitled "Helicopters, UFOs and the Psyche," which under the by-line of Dennis Stillings appeared in the July, 1987, issue of the *MUFON UFO Journal*, I have found in NOTE #6 the following pearl: "In 1954, a case occurred in France in which a UFO appeared with 'blades like a helicopter'."

Although the reference cited dates from 1983 (Ref. 1) this particular case allegedly occurring in Marcilly-sur-Vienne, France, on September 30, 1954, has a long track record. It was included by Guieu (Ref. 2) and by Carrouges (Ref. 3), but more

importantly, it is listed in Vallee's *Magonia* (Ref. 4) where the original references are clearly indicated to be newspapers (*Ici Paris* and *France-Soir*). Yet, everyone has been blind to the fact that the case is dubious at best.

But this is not all: a perfunctory survey of other French publications of the period (*Paris-Match*) reveals it was an admitted hoax! (Ref. 5). So much, then, for UFOs looking like helicopters or having blades which, after all, they don't seem to need.

-Dr. Willy Smith
UNICAT Project

REFERENCES

1. Evans, Hilary; *The Evidence for UFOs*, Aquarian Press, 1983, p.101.
2. Guieu, Jimmy; *Black-out sur les Soucopupes Volantes, Fleuve Noir*, 1956, pp. 161-162.
3. Carrouges, Michel; *Les Apparitions des Martiens*, Editorial Fayard, 1963, pp. 123-25.
4. Vallee, Jacques; *Passport to Magonia*, Regnery, 1969, p. 213, case #165.
5. Fiquet, Michel; *Francais Recontres Rapproches en France*, 800 1982 (undated).

Dear Editor,

Since at the end of his article, "Helicopters, UFOs and The Psyche," Dennis Stillings becomes somewhat of a film critic, mentioning a series of action films involving helicopters, I should cite a film he missed.

In *Through a Glass Darkly*, Ingmar Bergman's study of a schizophrenic, a helicopter lowers at the end to pick up the afflicted woman from her home. Anyone who has seen this ending surely will never forget it. The woman is alone and mentally-disturbed in her home and at first the sound of the helicopter (her savior?) is heard, and then the copter itself is shown.

However, Bergman is consciously using the helicopter as a dramatic symbol. In the films which Stillings mentions the helicopters are not intended symbolically, but as items of melodramatic window-dressing.

I question the wisdom of "reading

into" various situations a symbology which may only be valid in certain, deliberate instances.

In general, Dennis Stillings has generated a body of work in which symbols are important. He has written on alchemy, and various other venerable traditions of thought which involve the manipulation of a secondary, mental superstructure which philosophically "contains" reality. Unfortunately, the inventions of schizophrenics also present a secondary, symbolic system for containing a reality which may be personally unbearable.

I think that ufologists should recognize that too much "symbology" may indicate a form of mental disorder, and that such essays on symbolism as Stillings has presented in #231 of this magazine may be more representative of a "personal world" enjoyed by the author than of the consensus reality in which we must live our mundane lives.

-Eugenia Macer-Story
Woodstock, NY

Author replies:

My thanks to Ms. Macer-Story for the Ingmar Bergman reference. I shall add it to my video collection of helicopter imagery. As to her criticisms, I will first reply that I am not a film critic, and my reference to films are simply brief synopses of the parts relevant to my thesis. I am not interested in the quality of the films as art. However, as anyone familiar with art should know, there are contrived "symbols" such as one typically finds in allegories, and there are symbols that arise more spontaneously. The former type are generally easily reducible to matters of conscious intent. It is not so with the latter. The meaning of a stop sign can be exhausted in a few sentences; the meaning of, say, the Cross has not yet been exhausted even though libraries have been written about it.

Clearly the helicopter evokes some very unusual images from those closely associated with it. I did not invent their remarks and images, I simply collected them. Together these remarks indicate that the helicopter is functioning as a spontaneous, unconsciously generated symbol for

something essentially unknown.

The methods of analysis I use in partially elucidating this symbolism have been part of the intellectual apparatus of philology (decipherment of texts) and literary studies for at least 150 years and are quite academically acceptable. One of my richest sources of symbolic material relative to helicopters has come from members of the Vietnam Helicopter Pilots Society. They have no trouble tuning in to what I'm saying; in fact, they are quite excited about it. With absolutely no solicitation on my part, they have sent me materials, loaded with symbolism, that recount numerous para-psychological and mystical experiences in association with the technology and operation of helicopters. This material will be added to later editions of my paper. If Ms. Macer-Story wishes to extend her glib insinuations of "mental disorder" to this group of Vietnam veterans, I suggest she do so at their next annual meeting. I may well be there to watch.

-Dennis Stillings

Dear Editor,

Genuine abductees must have agonized over Mr. Wanderer's article in the July, 1987 issue of the MUFON UFO Journal.

The trauma, self-doubts and ridicule such individuals undergo can only be compounded by such irresponsible articles.

I'm the first one to support the right of an individual to express his/her opinion. I am also very anxious to strike out at accusations which are unsupportable and which do disservice to the UFO investigative cause.

Mr. Wanderer wrote that someone once said to him, "I wish they'd abduct someone credible for a change!" Since citizens with PhD's, military officers, and unusually intelligent citizens are among the abductees, I wonder who would satisfy such critics — Oliver North? Paul Harvey? Pete Rose? Or, how about Ronald Reagan?

Wanderer's insinuations and clever literary manipulations cause me to wonder if he didn't graduate from a school of journalism, not that journalists are necessarily devious.

He labels the UFO abduction phenomena as "...more serious fiction." The word "abduction" is constantly in quotation marks.

Mr. Wanderer's comment about "...clues...which lend some support to a 'psychological' explanation," indicates that he knows little of the subject of which he writes. Within his article he attacks Budd Hopkins's witness, Kathie. I know her personally and his words are an injustice.

Then, in summary the author decides there are only two solutions: one, the "...stories are objectively true..." or two, "...they create their 'abduction' story and sincerely believe it to be true."

Wanderer further declares that there is a "...lack of acceptable independent corroboration of any of these abduction stories." Shades of Philip Klass!!!!

The individuals who have heard electronic sounds, seen peculiar lights, experienced animalistic noises and have suddenly found themselves miles from where they should have been know Mr. Wanderer is wrong. His attack on Kathie is quite unfounded for there are many witnesses, a dessicated strip of lawn, power failures, and vibrations which support her testimony.

Anyone, who has shown Kathie his/her round, precise "hole" in the individual's shin and then had Kathie display two exact indentations, will never forget the affirmation and shock such evidence gives to a fellow abductee.

Individuals who have gone through the self-doubts, emotions, and anxieties of being an abductee certainly appreciate data that supports their own hypnotic revelations; a bit of detailed information that one thought only he/she had experienced. In these instances often there is no possibility that anyone could have known what the individual knew.

Scorched or scratched automobile finishes, military intervention, electronic damage, and other physical evidence is completely ignored by Mr. Wanderer. Apparently he has not done his homework nor has he dealt with valid abduction cases.

It would be nice if the UFO

phenomenon were simple. No cattle mutilations (which so many reject), no weird stories of screams in the night, interference with missiles, strange phone calls, or flashes of light in the night sky.

What is true is becoming more difficult as we learn more about UFOs. I would like for the abduction phenomena to be false but it is not. It is with us and will remain an integral part of our investigations. But to ignore or set aside all other investigative areas just to devote our resources to abductions would be gross negligence. Yet rejecting the abduction data would be a criminal injustice to our scientific thinking and methodology.

The greatest danger we face in investigating UFOs is ourselves. I'm beginning to believe we will forever remain disorganized because we are so busy attacking one-another. Such actions do not reflect intelligence unless they are based solidly on fact.

Let's get back to work and end this damaging argumentativeness.

-Richard D. Seifreid

Ohio State Director, Dayton

To Whom it may Concern:

Over the past thirty years of research and investigations into the UFO phenomenon and related fields of study, I have finally learned the truth to this phenomenon. These years were filled with mixed emotions and travel to far-away lands, plus the thousands of people whom I met under all types of circumstances. I was exposed to all types of experiences that life has to offer, some pleasant and some very unpleasant. But I did not stop in my pursuit of the truth, even though the sacrifices have been great.

The truth I have learned is not my truth but one which anyone will eventually come to if he searches for the truth long enough and is willing to make great sacrifices in life and humble himself to the point where his ego and pride will not interfere with the "learning process." If he or she is sincere and honest in their heart in their pursuit of the truth, they will find that truth. One will also come to the realization that there have been others

(continued next page)

LETTERS, Continued

throughout history that have known the truth about this phenomenon. You will not be the first nor the last.

My life must now take on new meaning, for when one is a child he participates in childish things but when he matures he must now lay these aside and accept the responsibilities that go along with this physical and spiritual maturity.

Hopefully, within the near future I can put down in words in a book all that I know and have experienced. But this will be no guarantee that your search for the truth will be answered by this book. It can only act as a guidepost for many, because you will have to experience many things for yourself. There is no easy way to the truth, it must be obtained through self-sacrifice and endurance, patience, faith, hope and charity and above all, a willingness to humble yourself before others.

I will now retire from the field of ufology, and it has been a pleasure to have had your friendship over the years. I hope that you may find the same peace-of-mind in knowing the truth one day. As Jesus Christ said, "the truth shall set you free."

-Tommy R. Blann
Arlington, TX

MUFON
103 Oldtowne Rd.
Seguin, Texas
78155

40 YEARS
IS LONG
ENOUGH

Fund for **UFO** Research

THE NIGHT SKY

By Walter N. Webb
MUFON Astronomy Consultant

OCTOBER 1987

Bright Planets (Evening Sky):

Venus should become visible again with difficulty during evening twilight toward the end of October. But it sets in the WSW only about three-quarters of an hour after sunset.

Jupiter, moving westward in Pisces, reaches a point opposite the Sun (opposition) on the 18th, rising then north of east at sunset. The brilliant planet (magnitude -2.9) outshines everything in the night sky except the Moon all night long this month and in fact will shine at its brightest and nearest Earth for the next 23 years! This largest of all planets can be seen below the Moon on the 7th.

Saturn, remaining at +0.5 magnitude in Ophiuchus, is very low in the SW at dusk, setting about 8:45 PM daylight time in mid-month.

Bright Planets (Morning Sky):

Mars, in Virgo, rises in the east about 5:30 AM in mid-October, about 1½ hours before sunrise. The red planet glimmers at a feeble +1.8 magnitude.

Jupiter crosses the southern sky and sets north of west at sunrise in midmonth.

Meteor Shower:

Conditions are favorable for the Orionids meteor shower this year because there is no Moon interference. A dark sky is particularly important for this shower; many of its members are quite swift and somewhat faint. The Orionids, radiating from the Hunter's upraised club, achieve a maximum rate of about 25 per hour toward dawn on October 21. Some of the shower's meteors can be seen about five days before and after the peak.

Moon Phases:

Full moon--October 7 (Harvest Moon)
Last quarter--October 14
New moon--October 22
First quarter--October 29



The Stars:

At 9 PM daylight time in mid-October the autumn sky symbol, the Great Square of Pegasus, is higher still in the SE. Meanwhile the Summer Triangle is beginning to slip into the SW.

Last month the aquatic constellations of the southern fall sky were introduced. The only bright star in this entire region is Fomalhaut in Piscis Austrinus the

MESSAGE, Continued

per ticket until October 7th and \$120 thereafter. (Meals and lodging are not included in this fee). Make check or money order payable to Omega Communications, P.O. Box 2051, Cheshire, CT 06410.

The International Society of Air Safety Investigators (San Francisco Regional Chapter) is conducting a "Symposium on the Investigation of UFOs and Other Visual Anomalies" on September 12, 1987 at the Crowne Plaza Hotel, 600 Airport Blvd., Burlingame, California 94010 from 9:00 a.m. to 5:00 p.m. Speakers scheduled are **Tom Gates, Richard F. Haines, Ph.D., James T. Harris, Richard Niemtow, M.D., Dr. Robert Nathan and Robert Sheaffer.** The tuition fee paid after August 10, 1987 is \$85 which includes admission to all sessions, continental breakfast, coffee breaks, luncheon and the no-host reception. Checks should be made payable to ISASI-SFRC and mailed to George Posner, 720 San Carlos Avenue, Albany, CA 94706-1810.

* * *

In conjunction with "The 4th International UFO Congress," a meeting of MUFON European members was held at the London Business School on July 13, 1987. The following people attended and participated in this important meeting: **Milos Krmelj** (Yugoslavia), **Robert S. Digby** (England), **Mike Wooten** (England), **Dr. Willy Smith** (UNICAT Project, USA), **Dr. Theodore Auerbach** (Switzerland), **Peter Harvey** (England), **William "Bill" Heinzerling** (USA), **Philip Mantle** (England), **Odd-Gunnar Roed** (Norway), **Robin Lindsey** (England), **Stephen Gamble** (England) and **Walter Andrus** (USA).

Dr. Willy Smith reported on the format and methods for collecting data for the UNICAT Project. MUFON supports the fine work that **Dr. J. Allen Hynek** initiated, which has been continued and expanded by Dr. Willy Smith. Robert S. Digby, Chairman of the International Committee for UFO Research (ICUR) gave a short presentation elaborating on the organization structure of ICUR, its goals and objectives, means of communications throughout the world, the need for standardization of UFO terminology and classifications as it relates to close encounter cases. ICUR is organized to act as a clearing house, a potential "think tank," and to help raise the scientific respectability of Ufology worldwide. An invitation was extended to all UFO organizations to join ICUR.

Dr. Theodore Auerbach, representing the Mutual UFO Network/Central European Section (MUFON/CES), read their activity report prepared by **Illobrand von Ludwiger.** (His comprehensive report summarizing their work for the past ten years will be published as a separate article in the Journal.) MUFON/CES is composed of members from the German speaking nations of Europe and operates as a private organization within MUFON. They were given the prerogative of joining ICUR as an organization, if they so elected, whereby they would be represented directly on the governing organization board.

Attendees at the meeting concurred that a MUFON Board of Director representing the "World at Large" was advisable. This would be in addition to the International Coordinator. Goals on the Agenda included selecting a new International Coordinator to replace Dr. Michael

Sinclair and to pick a Continental Coordinator for Europe which has been a vacant position. Several candidates were proposed, but no decisions were forthcoming.

Members were encouraged to submit articles for publication in the MUFON UFO JOURNAL, since it is an international publication. **Milos Krmelj** and **Philip Mantle** requested a list of MUFON foreign representatives and addresses, which will be provided upon activation of MUFON's new computer. **Odd-Gunnar Roed** had previously been invited to be the new Representative for Norway. He reluctantly declined due to his many other UFO responsibilities, however he recommended **Mentz D. Kaarbo** for this position, with Mr. Kaarbo's approval.

Before adjourning, it was proposed that another meeting for European members should be held in 1989 in conjunction with "The 5th International UFO Congress" to be sponsored by ICUR and hosted by BUFORA.

The MUFON 1987 International UFO Symposium Proceedings (222 pp.) are available from MUFON for \$15 plus \$1.50 for postage and handling. It contains all of the papers by the featured speakers that were received for publication before June 1, 1987 when the proceedings went to press.

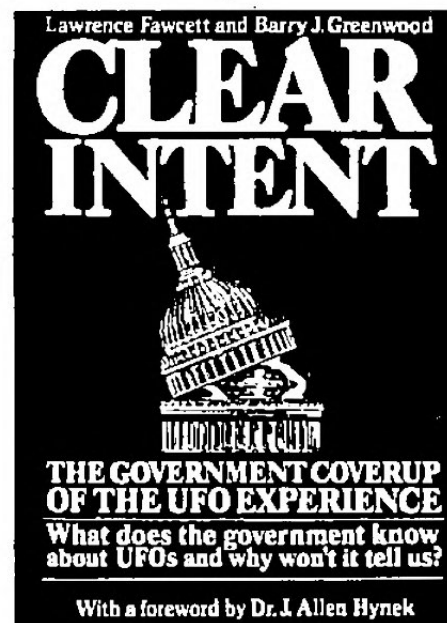

Southern Fish. Of all the first-magnitude stars seen from northern latitudes, Fomalhaut is the southernmost and often overlooked. But UFO investigators should be aware of the Solitary One, as the star is sometimes called, because it may be reported as a puzzling object by excitable onlookers. The star, by the way, can be found by extending a line almost straight down from the right side of the Great Square.

Other stellar IFO candidates in the midevening October sky that are affected by horizon refraction effects are **Capella (NE), Aldebaran (ENE), and Arcturus (WNW).**

DIRECTOR'S MESSAGE

by
Walt Andrus

The new Field Investigator's Examination that was administered to State Directors, State Section Directors and Field Investigators during 1985-86, will now be extended to Field Investigator Trainees and all others who have not taken the exam and desire to do so at this time. MUFON headquarters will provide a supply of examinations to State and Provincial Directors who will mail copies to their members. This will include an introductory letter and an answer sheet for 60 multiple choice questions, 31 true/false items and 9 "fill-in-the-blank" items. The answer sheet will be mailed to Mrs. **Shirley A. Coyne** per the instructions, who will grade the exam and advise the State/Provincial Directors and MUFON headquarters of the grade results.

Together with UFO case experience and related organizational involvement the exam constitutes a primary means to evaluate the trainee's potential for advancement to field investigator status. This is a so-called "open book" exam. You may take as long as necessary to complete it, and may use any resource available. The majority of answers can be readily found in a dictionary or encyclopedia. The remainder are major findings of one or more basic texts on the subject or are otherwise obtained through direct observations. There is no minimum score. Rather, your strengths as well as areas in need of improvement will be taken into consideration along with the number correct. In this manner, your state/provincial director will gain further insight concerning the trainee's and the organization's training needs.

* * *

One of the objectives of MUFON is to have a State Section Director assigned to every county or parish in the U.S.A., so immediate response to

UFO sighting reports and investigations may be conducted promptly and thoroughly. The following new State Section Directors have volunteered their services: **Thomas Enriquez**, M.P.A., for El Paso and Hudspeth in Texas; **F. Donald Fenhagen, Jr.**, for Baltimore County in Maryland; **Tom Culnan**, for the New York County of Saratoga; **Donavon "Don" Johnson**, for Burleigh, Morton, and Oliver Counties in North Dakota; and **John R. Ibach** for Berks and Lancaster in Pennsylvania.

Some of these same gentlemen have taken on other important roles. Mr. Fenhagen has expressed a desire to provide professional public relations assistance. Tom Culnan, a visual effects artist, has started constructing life size models of humanoids as reported by witnesses to be used for MUFON public UFO exhibits. Don Johnson will conduct personal interviews with the police officers who were witnesses to several UFO sightings as reported in the Bismark (N.D.) Tribune on March 11, 1987. (Bob Boyd, please note.)

Lawrence J. Radick, M.S., a college instructor in Ann Arbor, Mich., has volunteered his expertise as a translator for French, Russian, German, and Spanish, which he teaches. **Paul F. Kisak**, M.B.A. & B.S.E., is a new Consultant in Electro-Magnetics. He has had extensive experience in satellite intelligence gathering assignments and computer applications.

* * *

Peter A. Gersten and **Patrick Huyghe** are sponsoring their Second UFO Conference on Saturday, September 26, 1987, at the Henry H. Wells Middle School in Brewster, New York. Speakers scheduled include **Budd Hopkins** and **Philip Imbrogno**. There is no admission charge and the

public is invited. For more information telephone (914) 739-6830 or write to **Patrick Huyghe**, P.O. Box 250, Lake Peekskill, NY 10537.

A five day symposium on UFOs will be held from September 28 through October 2, 1987 at the Collin County Community College in McKinney, Texas (about 30 miles north of Dallas on highway U.S. 75) sponsored by the Department of Science-Health and hosted by **Michael L. Broyles**, Ph.D. and **Scott Stevens**, Student-Director. Since it is basically a student and community affair, the majority of the speeches will be delivered during the lunch hour from 12 noon to 1:00 p.m. **Walt Andrus** will open the symposium with an introduction to the UFO phenomenon, followed by a slide-illustrated lecture on the Japan Air Lines case over Alaska on Monday, September 28th. **Budd Hopkins** will speak on Thursday, October 1, 1987. Other speakers are being scheduled, including **Hal Crawford**, the well known UFO artist. On Friday, October 2nd, the speakers will field questions and provide answers to this intriguing enigma. MUFON's photographic exhibit will be on display all week in the student lounge. The symposium will be open to the public at no charge.

John W. White has announced that Omega Communications is presenting "The UFO Experience" — a weekend with researchers and contactees on November 7-8, 1987 at the Ramada Inn in North Haven, Connecticut. Speakers scheduled are **Betty Andreasson Luca**, **Ellen Crystal**, **John W. Donoghue**, M.D., **Lawrence Fawcett**, **Betty Hill**, **Budd Hopkins**, **Philip Imbrogno**, **David Menke**, Ph.D., **Patricia Sable**, **Marianne Shenefield**, **John Timmerman** and **John White**. Registration fee for the program is \$100

(continued on page 23)