

The Journal of Borderland Research

TABLE OF CONTENTS

MY SEARCH FOR RADIONIC TRUTHS

By R. Murray Denning
Reviewed by Alison Davidson.....1-8

INTEGRATION OF THE LIFEBLOOD OF THE EARTH

By Ellen V. Wilmont Ware
From the "PENDULUM" November 1953.....9-12

THE LAKHOVSKY MULTI-WAVE OSCILLATOR

By Klark Kent.....13-22

CLIPS, QUOTES & COMMENTS

Your New Director * How I View The World *
Newton's Laws Are Full Of Flaws * Scientific
Idiocy * New Light On The Changing Face Of
Mars * Life From Inorganic Material * Green
Areas Betoken Martian Life * Psychotronics
Cruise * The Further Adventures Of Elaine
Peick * Rainbow Toner Update * Letter From
Riley * No Need To Know * Living In The Dark
Ages * The Link * East Of Tomorrow * Color
Changed Her Life * Spectro-Chrome Metry
Contacts * Bridge To Infinity * The Cameron
Aurameter * Experimental Anti-Jet-Lag System *
Implosion.....23-36

THE JOURNAL OF BORDERLAND RESEARCH

BSRF No. 1 Published by Borderland Sciences Research Foundation,
PO Box 549, Vista, California 92083-0190. Edited by
the Director, Thomas Maxwell Thompson.

The Journal is published six issues a year with the assistance of the Associates, at the Director's home, 1103 Bobolink Drive, Vista. It is printed, 36 pages an issue. The Foundation is incorporated under California law, May 21, 1951, #254263, and has been in continuous existence since then. Correspondence is addressed to the PO Box. The Journal is included in the Foundation membership of \$15.00 a year, domestic. Foreign membership/subscriptions are now \$15.00. Single copies and back issues of the Journal are \$2.50. A donation of \$15 domestic or \$15 foreign will also bring the Journal to those who don't care to join BSRF. Alison Davidson is the office manager and Secretary-Treasurer.

PURPOSES OF BSRF: This is a non-profit organization of people who take an active interest in unusual happenings along the borderland between the visible and invisible worlds. In the words of the late Meade Layne, founder and director of BSRF from 1945 to 1959: "BSRA publications are scientific in approach but employ few technical expressions. They deal with significant phenomena which orthodox science cannot or will not investigate. For example: The Fortean falls of objects from the sky. Teleportation, Radiesthesia, PK Effects, Underground Races, Mysterious Disappearances, Occult and Psychic Phenomena, Photography of the Invisible, Nature of the Ethers and the problem of the Aeroforms (UFOs). In 1946 BSRA obtained an interpretation of the phenomena which has come to be known as the Etheric or 4-D interpretation; it has not been radically altered since that time. This continues to be the only explanation of the UFOs which makes good science, sound metaphysics and common sense."

The investigation of the invisible worlds is important to our evolution and awakening from the ordinary consciousness in which most people 'sleep.' As Riley Hansard Crabb, second director of BSRF (1959-1985), has pointed out, "The input of the five senses do not give us answers to the problems of life, they only pose more questions."

The main function of BSRF is to act as a clearinghouse for information, and to make that information available at as low a cost as possible. Headquarters acts as a receiving, coordinating and distribution center. We welcome input, in letter or article. An important part of the Director's work is to give recognition, understanding and encouragement to people who are having unusual experiences of the borderland type and/or are conducting research in any of the above fields. For consultation on borderland phenomena or to keep us informed of current borderland researches being carried on, write or phone (619) 724-2043.

Donations and bequests toward Foundation research programs and expenses are welcome.

Catalog of BSRF literature and research devices is \$2.50.

MY SEARCH FOR RADIONIC TRUTHS

By R. Murray Denning

Reviewed by Alison Davidson

"Another book on Radionics! That subject which is a scientific tease to those who work in it, and a scientific anachronism to those who work in the orthodox world."

So Mr Denning introduces this work that should find a place on the bookshelves of Radionic practitioners everywhere. Over 25 years of research into the whole spectrum of healing have been focussed here, with special reference to those Radionic practitioners of the past whose gifted minds helped shape Denning's own path. But this book also provides a missing link in Radionics, revealing some of the 'lost' knowledge in radionic history, as well as projecting this art into the future where it will be able to take its place side by side with the medical profession.

"I have always maintained, and still do, that if one is working on a sustained campaign for universal medical recognition, the fact must be faced that it will not come about unless there IS a sound scientific backgroundI examine and enlarge on this statement in my book, explaining in which way I feel it can be achieved."

Denning's first encounter with 'unorthodox' healing was quite dramatic. He was afflicted by an 'incurable' spinal complaint, which dominated his life for 25 years, until at the age of 45 he met, and was cured by a remarkable Healer working in a London Spiritualist Centre. This experience changed the whole course of his life. Here lay the beginning of his path into Radionics and healing, and also the way to realise his dream - that one day Science would prove Radionics to be true.

WHAT IS RADIONIC THERAPY?

"It is a form of 'Absent Healing' by the use of a 'Force' or 'Energy' in conjunction with instruments.

"What is this energy and how does it manifest? To the first part of the question the answer is that this is unknown. There are, however, some men and women who, when they have reached a certain point in 'inner development' do know what it is, yet are unable to describe it in terms acceptable to science. Others accept its existence intellectually, though they too are unable to define it. Still more people can use it without experience or understanding.

It has been called many names, e.g. Reichenbach called it Odyle; Reich, Orgone; Paracelsus, Munia; Eeman, Y. Force; Alchemists, First Matter; Theosophy, Fohat; Alice Bailey, Cosmic Fire.

"It is the Energy that manifests itself through all forms of expression on earth; through physical form with all its complexities - physical, chemical, biological, electrical, magnetic etc, and through the etheric and subtle fields of which life is composed. It is the Energy that flows through the hands of a 'Healer'; which is released through the shape of the Great Pyramid; through geometrical and numerical patterns. It is, in fact, Cosmic Energy."

The pioneers of Radionics often spent their whole lives experimenting with this Life Energy and Denning pays tribute to the great value of their work, giving fascinating insights into their lives and discoveries, as well as taking the reader on a journey along his own search for Radionic truths.

"The works of the pioneers, particularly for those who have not had the opportunity to study them deeply are of absorbing interest. Their approaches to the development of healing techniques varied from individual to individual, but in the ultimate all were striving to a single end - that of alleviating the disabilities of mankind."

THE PIONEERS - ABRAMS AND DR. DROWN

"Strangely, the expounders of some of the great new ideas of history were frequently considered on the lunatic fringe for some or all of their lives.

If one stands up and is counted from time to time one may be knocked down. But remember this, a man flattened by an opponent can get up again. A man flattened by conformity stays down forever."

Dr Albert Abrams was born in 1863, and became Professor and Director of the Medical Clinic in San Francisco. He inherited a vast fortune from his father but decided to devote his life to medical research. Commenting on Abram's work "New Concepts in Diagnosis and Treatment" Denning says:

"Firstly, he expounds in great detail matters concerning vibrations emitting from the body, both from the physical and 'inner' points of view. And although his work does not stress the occult teachings, his knowledge in this field must have been extensive."

Abrams writes: "The present age marvels at man's conquests of the forces of nature. Yet, this age of energy can only be triumphant when man can know and then direct and control the more important forces within himself."

"Dis-occulting the occult will be possible when one attains a better understanding of the activities of living cells and when the biologist shall know the laws that govern cell-growth with the accuracy of the scientist knowing his laws."

Dr Ruth Drown also worked to bridge the inner and outer worlds, to provide a link between occult knowledge and scientific experiment. As a student and follower of this remarkable woman, Denning devotes a chapter to her basic technique and philosophy. In her book called "Theory and Technique of the Drown HVR and Radio-Vision Instruments" she writes:

"Very ancient writings deal almost wholly with the rates of vibration of all things pertaining to the mental and physical world of mankind. It is impossible to diagnose and treat the physical body without relating it to the mental. After two years of using our radio instruments, we found in the deeper study of ancient wisdom amazing and satisfying corroboration of our own development of rates and vibration.

"Obviously, a complete and scientifically accurate 'blue-print' of the condition of the patient's body is of inestimable value to the doctor. This is possible to obtain with the HVR Instrument, since it may be tuned in to any part of the body for measurement of function and for disease. In fact, measurement of function of the glands and organs in the body is the fundamental basis on which a diagnosis with this instrument is built."

Drown Mechanical Detector

Model A-458 - Complete Office Model, three inch screen oscilloscope.



TROMP, LAKHOVSKY AND CRILE — DOWSER, PHYSICIST AND SURGEON

Another chapter is given to Professor S.W. Tromp, a geologist not so well known in Radionics, but who performed extensive experiments in dowsing and exploring the electro-magnetic fields of the living body, the earth and the atmosphere.

Tromp proved that Radionics could be explained on a scientific physical basis. "Few people have heard of Professor Tromp in the Radionic sphere, but I feel that his contribution is of such importance to our subject, that I now give extracts from his book (Psychical Physics - A Scientific Analysis of Dowsing, Radiesthesia and Kindred divining Phenomena). This will enable a picture to be formed of the depth of his researches and his conclusion that Radionics is not a para-psychological therapy having no basis in physics."

Others were also experimenting with electrical energies and force-fields. Lakhovsky and Crile were coming to similar conclusions from very different areas of research. "In his admirable book entitled 'The Phenomena of Life', Dr Crile points out that electrical energy plays a fundamental part in the organisation, growth and function of protoplasm. Lakhovsky and Crile, pursuing their investigations independently, have come to identical conclusions.

"While the engineer physicist was experimenting with his oscillating circuits, the surgeon was testing in his clinic the principles of radio-electricity. The foundations of Lakhovsky's theories rest on the principle that life is created by radiation and maintained by radiation. Crile states that man is a radio-electrical mechanism and stresses the significant fact that when life ends, radiation ends.

"Like Lakhovsky, Crile holds that living cells are electric cells functioning as a system of generators, inductance lines and insulators, and that the role played by radiation and electricity in living processes is no more mysterious in man than in batteries and dynamos."

FROM THE ARCHIMEDIAN SPIRAL TO MOGEN DAVID TRIANGLES

Darrell Butcher - "Creator of the First Automatic Radionic Instrument" - spent much of his life as an aircraft engineer, a career which proved invaluable when in the 1950's he became interested in Radionics.

"In the beginning he found himself unable to use the conventional means of registering the Radionic impulse by 'stick-pad' or pendulum but where most men would have given in and sought another field of endeavour, he, with his creative faculty and technical skill, overcame this obstacle by the simple expedient of designing his own very personal instruments. Some, at least, appear to work entirely on their own, whilst others make use of the operator's mind." The Principle of the Archimedian Spiral runs through all his work and can be seen clearly in the design of the Meter I.

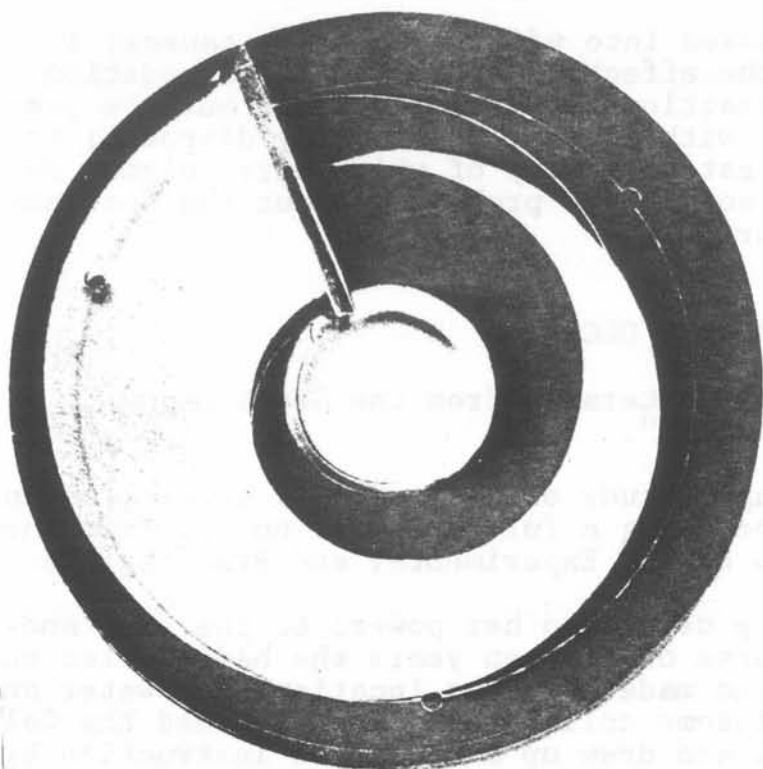

Inner Plate of Meter I

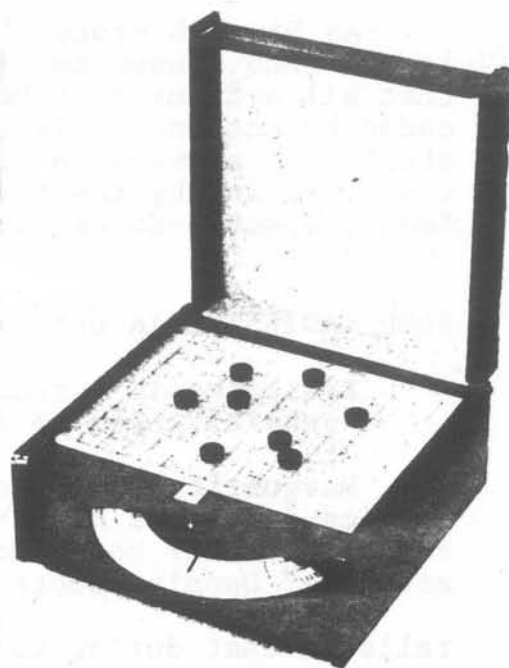

Pegotty Instrument and Meter

The Pegotty Instrument consists of a black perspex box frame with a white top marked with a rectangular design and divided into 120 squares. Each square has a small hole to take a round black peg. When a transverse beam of light is reflected across it, then a message can be reflected onto a nearby sample.

As the Archimedian Spiral inspired Butcher, so the 'mysterious Mogen David Triangles' provided a key to the work of Dinshah Ghadiali. "A book on Radionics would be incomplete without a chapter on colour," Denning writes. "I have therefore chosen the work of a quite remarkable man, born in Bombay to a family of Zoroastrian faith, who lived a life of astonishing scope and enterprise."

Among other achievements, Ghadiali wrote the three volume work "Spectro-Chrome Metry Encyclopedia", and was associated with Thomas Edison, Nikola Tesla and other noted scientists of the 1890's. His Theosophical studies provided the key to his work on colour therapy.



As Dinshah wrote: "I looked into effects to trace causes; I looked into causes to find the effects. Working on the foundation that all actions must have reactions and all reactions must be preceded by actions, I laboured with all the means at my disposal; to obtain the answers to the questions, many of which were enigmas for centuries and by the time I solved the problems or cut the Gordian-Knots, Spectro-Chrome was born".

FROM RADIESTHESIA DEEPER INTO THE OCCULT

Radiesthesia - translated literally from the Greek means "sensitiveness to radiations".

Marguerite Maury took up a study of Radiesthesia after studying physics in Vienna and then becoming a fully trained nurse. From the Foreword of her book "How to Dowse, Experimental and Practical Radiesthesia" Denning quotes:

"She developed her powers to the full and tells me that during the course of fifteen years she had carried out more than 70,000 diagnoses and made numerous locations for water and minerals... With the help of some collaborators she founded the College Radiesthetique Francais and drew up a course of instruction by correspondence which has been followed by more than 900 pupils."

Denning has extracts from this correspondence course with her special emphasis on Form and Geometrical Figures. Studying this work led him into the significance of numbers... "fundamental to all Radionic systems, the very nuts and bolts of its existence. Whether they are regarded as key links to a psychic plane or as creating scientifically regarded radiations is a personal conviction often debated in Radionic circles." His quest took him deeper into Esoteric lines of thought, for the Principles involved in the meaning of numbers are also the Keys to understanding the natural laws of the Universe.

He contacted Ruth Drown several times asking if there was a fundamental Law by which she had arrived at the numbers for her work. Eventually she wrote back saying: "I have worked out a comprehensive study on the numbers of the Qabalah, which, of course, go back to the very essence of Life itself. It seems quite true that people are using these numbers in what they call a 'code'". It was to this 'code' that Denning turned his attention, pursuing the Ancient Wisdom and the universal language of symbolism through which higher states of consciousness are reached.

He explored the teachings of the Builders of the Adytum, a Western Mystery School founded by Dr Paul Case, and the practical application of the Hermetic Arts which include the Qabalah, Tarot, Alchemy and Astrology. Concerning the Tarot, Dr Case writes:

"Tarot is a pictorial text-book of Ageless Wisdom. From its pages has been drawn inspiration for some of the most im-

portant works on occult science published during the last seventy-five years. Its influence on the minds of a few enlightened thinkers may be traced throughout the history of the modern revival of interest in esoteric science and philosophy."

The Tarot and the Qabalah are inextricably interwoven and the diagram below which Denning gives, is the basis for the construction of the Qabalistic Tree of Life, the key to the meaning of so-called 'Arabic' numerals, and a key to the geometrical construction of the Great Pyramid - to name "but a small selection of the mysteries to which this one diagram affords a clue".

Another occult code Denning explores is the cryptic language of mediaeval Alchemy: "The mediaeval chemical science, whose great objects were the transmutation of the baser metals into gold; the discovery of the universal cure for disease and the means of indefinitely prolonging life". He compares the operation of the Great Work of Alchemy with the stages of spiritual unfoldment as taught by the many branches of Yoga. From the Western Tradition he meets with the East and finds the same message in each:

"The man who has discovered and learnt how to manipulate the internal forces will get the whole of nature under his control. But he has to start with his own nature."

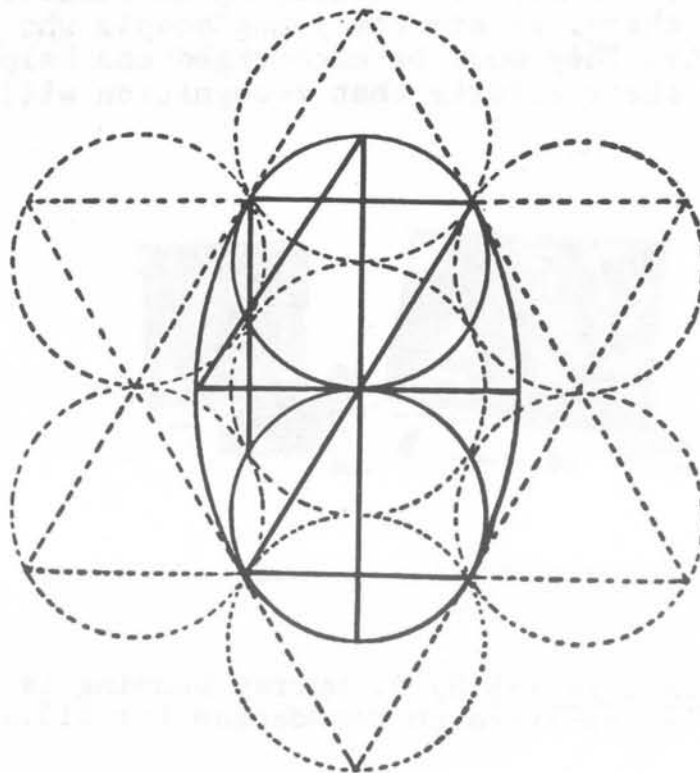

Key to the Cosmos and Numbers

As Denning points out, it is up to each practitioner of Radionics whether or not they wish to consciously pursue a system of esoteric teaching. "As often happens when one comes in contact with Radionics, one is suddenly confronted with possibilities of deliberately developing one's sensitivity. For many this is not a major factor, and it must be made clear that one can become an excellent Radionic Practitioner without esotericism". But there are the options.

RADIONICS AND SPACE-AGE TECHNOLOGY

"Today Radionics is facing a new challenge - that of assimilating itself into a galloping technical and scientific age. It must adapt and quickly if it is to be recognised as a natural segment in the general healing spectrum of the next quarter century and beyond."

Denning believes that the will and the means to adapt to space-age technology are there; that the use of a more advanced form of radionic computer would be of great value in storing all the information needed for rapid analysis, instantly accessible to the practitioner. But he stresses the 'human factor' in New Age Radionics, allowing the practitioner to make full use of his ESP faculties while taking advantage of modern technology to remove much of the labour involved.

He writes: "The very survival of Radionics over three-quarters of a century is encouraging in itself... The will is there, so are the young people who will be its catalysts. They must be encouraged and helped, since it is by their efforts that recognition will come."

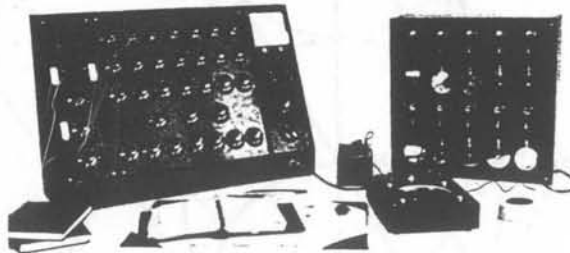

Author's new Diagnostic and Treatment Instruments

MY SEARCH FOR RADIONIC TRUTHS by R. Murray Denning is available from Borderland Sciences Research Foundation for \$15.00 post paid.

INTEGRATION OF THE LIFEBLOOD OF THE EARTH

By Ellen V. Wilmont Ware
From "PENDULUM" A Monthly Review of
Radiesthesia, Vol. 4 NO. 2, November 1953

Readers of the "Pendulum" who are also readers of "Country Living Books," "Trees," "Rural Economy," the "Soil Magazine" or "Organic Husbandry," may remember my writings on the discovery of an ancient system of Land Water Control, the introduction of which has invariably been followed by an amazing improvement in health and fertility (both animal and vegetable) in the areas concerned.

"What gave you the idea in the first place?", I am constantly asked, in conversation. I can only reply in the words of a famous scientist, "Ideas come out of space!"

The idea, upon which my work has been based, is as follows: "That it is possible to induce rainfall, as it touches the earth, to commence to move towards specially prepared focal points, where it will commence to spiral downwards, to replenish underground streams and centres of moving water, beneath the earth's surface; instead of streaming off, on, or near, the surface of the land; filling the surface water channels far too rapidly and causing mud and floods to make their appearance."

ANCIENT KNOWLEDGE

This idea was quickly followed by the amazing discovery that the idea had evidently been in the minds of the ancient agriculturists, who first brought these islands (British Isles) to fertility, out of swamp and forest!

Not only here, in this Gloucestershire valley, but all over England, and in parts of Wales too, there are to be found the necessary earthworks and the chequer-board pattern of field and pasture, which are parts of the System; although, now, completely prevented from functioning by the application of modern ideas of Land Drainage.

Modern Drainage increases the rate of surface run-off, and prevents the far more rapid inward rotational movement. No puddles form where inward rotation of water is functioning; and in such areas there is no mud! Earth and water become permanently dissociated and air takes the place of stagnant water in the soil, wherever rainwater is allowed to percolate the earth with a natural inward spiral movement. This action can be induced by man, and adapted in accordance with his needs.

The radiesthetist will be, it seems certain, most interested in that part of the discovery which is connected with the incidence

of disease; and of the effects on disease which follow the introduction of this method of Land Water Control in any given area.

NEW LIFE IN THE VALLEY

In Parts of this valley, where I have not yet been permitted to set the System working, many dead and dying trees are to be seen. In areas where the ancient focal spots have been once more set to work, the diseased limbs, and the cankered bark of the trees, have all been shed, or smothered in new, healthy growth.

The corky excrescences which covered the twigs and branches of of the elm trees, immediately began to shrivel up, and then to drop off, once the water of an area had started to move spirally inwards. Where, before, there were diseased growths, now there may be seen shining, healthy tissue, full of lenticels and growing at a rapid pace. The elm leaves may have been not much bigger than one's thumb nail, but now there will come, on the younger elm branches, large, tender, bright green leaves, which might be mistaken for nut leaves.

Willow trees - old and pollarded - may have been falling apart, riddled with the tiny holes of parasites. Now "new trees" will take their place. The splits are actually mended by new tissue which grows rapidly up the edges of the split portions, reuniting them and enabling the tree to take on the appearance of a new one, as new bark covers the whole area in succeeding years.

In our valley, the waterside rushes, which, formerly, grew for awhile and then turned yellow and died away, now grow right up to flower and fruit!

As for the rushes in the boggy valley pastures - where are they?

The little acre known as "Poor Land" or the "Parish Field," which I rent from the Parish Council, was, when I took it over, in January 1939, a mass of rushes and water weeds. Some, then called it "Rushy Meadow." Now, there is not a rush to be seen! The rushes have been grazed to extinction by my farm animals, which, previously would eat but little of the sour herbage of this low lying pasture; which, nearly every winter, disappears for a while under many feet of Severn floods, which sweep across the three-mile-wide valley; which is believed to have been, in previous days "less subject to waters." (vide the 16th century historian Leland).

THE HUMAN LINK

What place have human beings in this long-forgotten System, which I have re-discovered?

We have no "roots" like plants. We, and the animals, move from place to place. We, and they, may gain great benefit from eating produce which is obviously more healthy; from the new-textured, sweet-smelling, and richly-coloured soil which is now to be seen wherever the System is working.

Is there more than this? I think there is.

In this System, allowance is made for tidal movements in the waters of the earth - the rhythmic "back-and-forth" of free water, which may be observed on the surface of the sea, but which, manifestly, cannot end at the sea shore. This movement must extend throughout the earth's surface, and outwards into space, also.

Much is written regarding the "stress" of modern times. I am convinced that much of this stress is connected with that unremitting onward "forward-traction" of the waters of the countryside - as though the "arteries" of the earth had been severed, while the "veins" had long since ceased to function!

COSMIC INTERCONNECTIONS

I look upon the Moon as having a similar function with regard to the Earth, as the Heart of man has with regard to his Body.

In this connection, it is interesting to note that the Ancient Chaldeans of Ur, (who, it seems probable, understood the principles which I have rediscovered) accounted the "Goddess of Fertility" to be none other than "Nin-Gal" the Goddess of the Moon!

There should be, I am convinced, (by practical experiment) a possibility for the earth's waters to draw back and forth, as well as on and on!

It also seems probable to me, that cosmic rays, coming out of space, need a healthy, and balanced environment in which to work naturally, and therefore beneficently in the service of mankind.

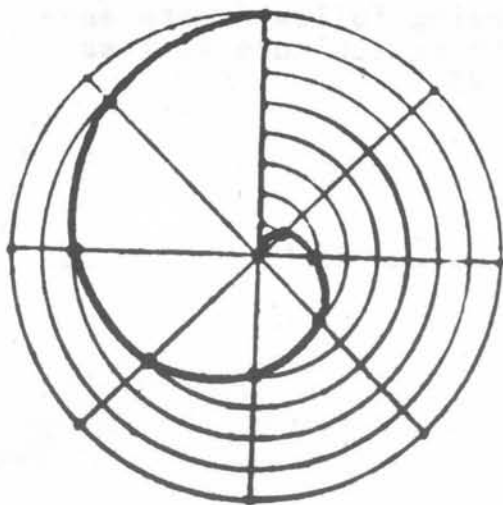

May it not be during sleep (when we are, as it were, "rooted" to an area), that the influences which spell the difference between health and disease are at their strongest - for we, as we rebuild our defences during rest, are then surely, most subject to external influences?

SECRETS OF THE SYSTEM

What are the secrets of this new (or very old) System? What are we to do, that we may start the System at once? Can we start in our own gardens? Yes, we can!

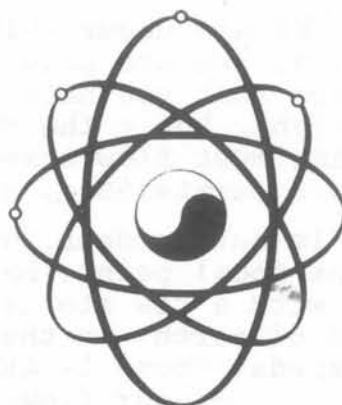

We cannot, however, get full results until the "Powers that Be" in Land Drainage, see the light also.

"We are under Whitehall," I have been told by Land Drainage engineers. "We are paid for our work and we must do as we are told. We can see that you have changed the texture of the soil. We know you are right, but - the Ministry of Agriculture says that all rivers and streams must flow straight to the sea; and dams of earth and stone are not permissible, according to modern drainage ideas!"

In our gardens, we may begin, however. That circular flower bed is the focal point. Make it, first, a "saucer," - a depression - made firm with a few stones in the centre. Then, on the "saucer," place a mound of earth. In the surface of this mound you will set your plants and seeds. Mound it as high as possible by adding humus to lighten the soil. Mound your flower borders also. Never let them be flat. Air pressure will then drive the rainfall towards the "cores" of the flower beds and flower borders. Thence it will spiral downwards.

You will have started inward rotation. In time, no doubt, others will follow!

"For as the rain cometh down, and the snow from heaven, and returneth not thither, but watereth the earth, and maketh it bring forth and bud, that it may give seed to the sower and bread to the eater.

"So shall My Word be that goeth forth out of My Mouth; it shall not return unto Me void, but it shall accomplish that which I please, and it shall prosper in the thing whereto I ^{sent} it.

"For ye shall go out with joy, and be led forth with peace: the mountains and the hills shall break forth before you into a singing, and all the trees of the field shall clap their hands.

"Instead of the thorn shall come up the fir tree, and instead of the brier shall come up the myrtle tree: and it shall be to the Lord for a Name, for an everlasting sign, that shall not be cut off."

(The ideas of the author have some resemblance to those of Dr. Schauburger but were evolved separately over a period of years. The principle enunciated should be capable of being followed with ease overseas where Ministerial interference with agriculture is less evident. Egerton Sykes, Editor - PENDULUM 1953)

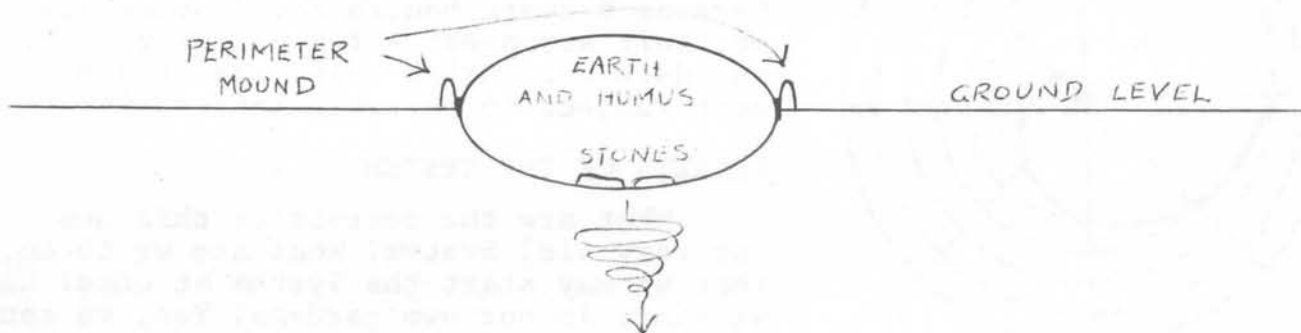

The Lakhovsky Multi-Wave Oscillator Power Supply

by Klark Kent

I thought "nuts and bolts" would be a good title for this article because we are concerned here with actual hardware-building the devices and getting experimental results; the time for talk and more theory is over. In these late days before the new age breaks in upon us, it is our duty to build the gadgets that we have been reading about all these years.

Many of us have read that cult classic, The Lakhovsky MWO, published by BSRF in which electrical wizard Bob Beck astounds us with tales of an electronic box that is wonderful indeed. Remember this book was written about events happening in 1965- what an historic period: Vietnam, acid, UFO's... And the experimenters- Bob Beck, Ed Skilling, building the MWO straight from an old original; one perhaps built by Lakhovsky himself. Heavy movie as they used to say. So if you don't have a copy of The Lakhovsky MWO, then get one because it's a prerequisite for this article. Looking at the schematic on page 5, we will eliminate every thing but the battery, switch, Ford coil, spark gap, capacitors and Tesla coil. A large high voltage diode is added to rectify the output of the Ford coil. This leaves us with a stripped down but operating circuit that powers the MWO antenna.

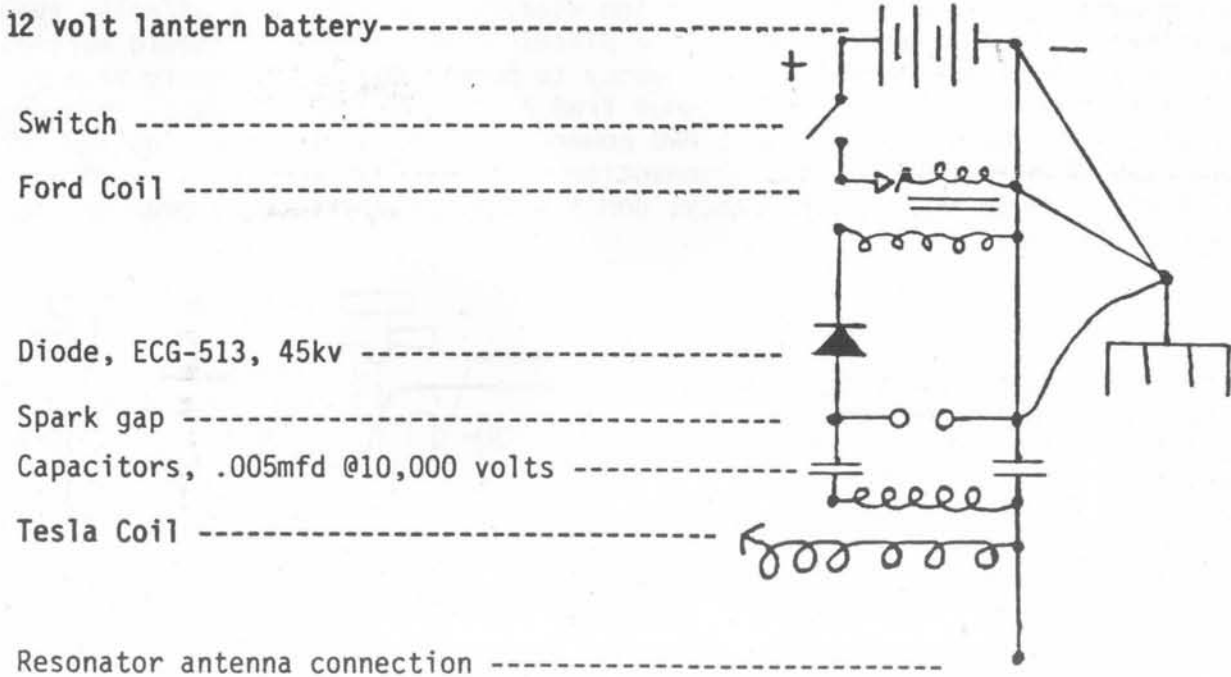

Before we get too far along let's remember that the MWO is an experimental device, not to be used for any healing or medical purposes. To be on the safe side, all experimental subjects should be in good health. My personal opinion is that good nutrition, exercise and avoidance of harmful habits such as smoking are the real foundations of good health. In any case, this article focuses on the high voltage power supply, the use depends upon the individual experimenter.

As a worker in the technology of the new age, I do not know what electricity is. I suspect that the elusive nature of natural phenomena such as electricity (remember Ben Franklin), places this category of event into that unknowable realm of love and god. We all have some knowledge of conventional science as taught in the textbooks; still we are dealing with an aspect of "the force" and should remember that ultimate understanding comes not through the brain- rather it comes through the heart and emotions. Not that us tinkerers can't keep at it- Yes indeed; it is work that counts and we can work our way into a little cosmic understanding if we just keep at it.

We start at the 12 volt lantern battery; it is readily available and using a battery means no problems. Plugging into the wall socket puts us out of the experimenters category and into the public safety codes which cover too much of our lives already. Due to the controversial nature of devices like the MWO, it's best to make them as safe as possible. If anything ever goes wrong during use, then lawsuits will fly like feathers. Don't be fooled like I have been so many times; a 12 volt lantern battery has plenty of power- not lethal power that comes from the utility company, but an ample amount to run the power supply for the MWO- and an abundance of power to shock the unwary !

And now the basic box, the stripped down power supply for the MWO. And let's realize that this power supply is a rugged portable unit-able to run a Kirlian photography kit, able to demonstrate ion wind, study Tesla coil effects, even experiment with anti-gravity as in the Biefeld-Brown effect. I should mention that later units are tunable in frequency to permit use as extremely powerful ELF generator. The device can be tuned from 4 HZ to beyond microwave frequencies. For use as ELF generator, connect MWO power supply to a B&K Precision 150 MHZ Universal Counter # 1822. Make connection to frequency counter at output of 555 timer chip to monitor frequency; don't connect the frequency counter to any high voltage.

After the battery comes the model T Ford coil, which is simply an induction coil used to produce our first stage high voltage.

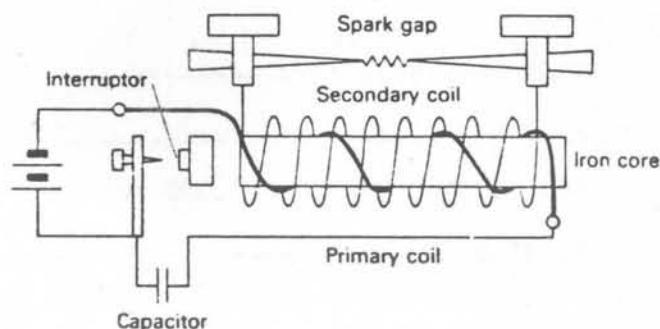

The induction coil is a transformer of direct current electricity and we use it to raise the voltage of the electricity. The coil consists of a few primary turns wound around an iron core with a large number of secondary turns surrounding the primary. Battery current magnetizes the core so that it attracts the interruptor arm and breaks the circuit. The interruptor is called a relay in modern terms. When the circuit is interrupted, the magnetic field around the iron core collapses, inducing a large emf in the secondary winding - this is our first stage high voltage.

The Ford coil is great for what it does but it is obsolete; it's nearly impossible to buy except at specialty auto mail order houses and the Ford coil is difficult to mount due to the friction contacts. The modern auto ignition, induction coil has a nut and bolt mount and this is important to us because we are actually putting these devices together and using them, not just talking about it! The Ford coil output is at a steady frequency and this limits the versatility of the MWO power supply.

A 555 timer chip controls a npn 3055 power transistor to switch the battery current on and off at a controlled frequency with the use of a variable resistor. We vary the frequency of the pulses going in to the induction coil to control the frequency of the high voltage coming out of the coil. The frequency is the number of times the electromagnetic field around the coil core expands and collapses per second. According to some sources, resonant frequencies exist for both inorganic and living objects. A guitar string will sound if its note is struck nearby. The oscillating electromagnetic field around a coil is capable of resonance. According to others, the human organism is capable of resonating to frequencies; 7.8 cycles per second has been suggested as a resonant frequency found in nature.

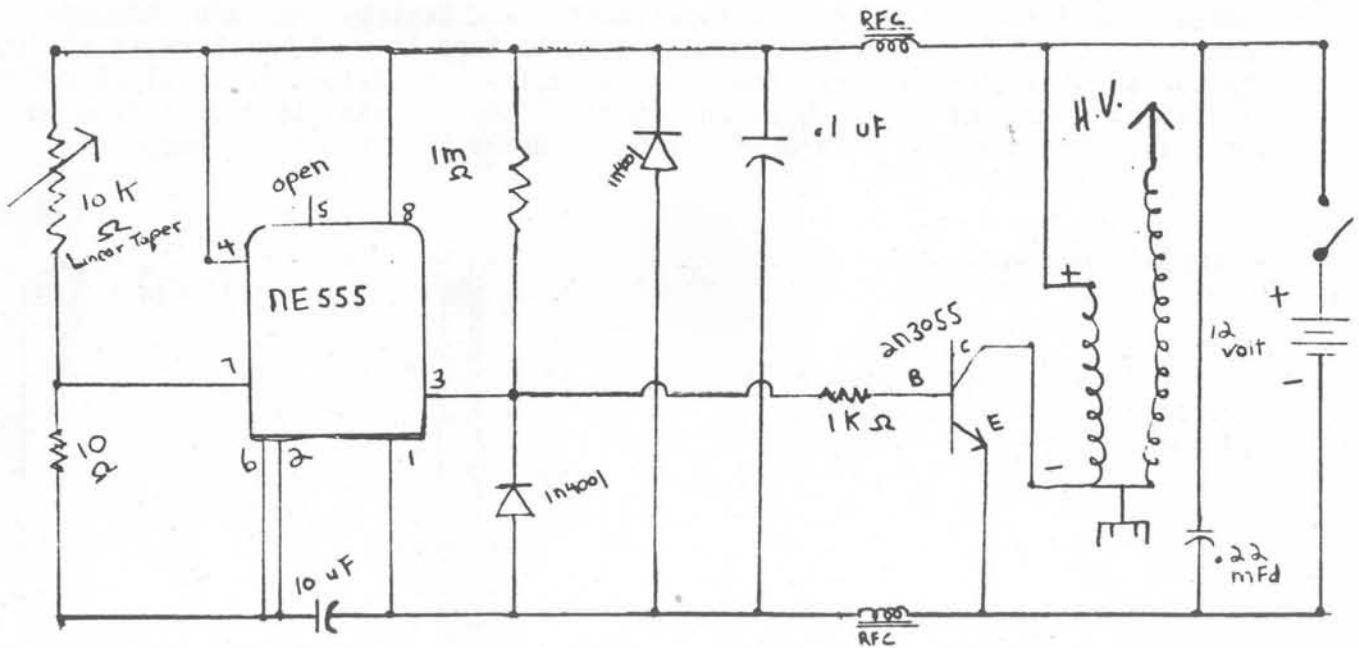

LET'S BUILD:

Start by rounding up the various components and making the subassemblies: the battery, the 555 timer chip circuit (see diagram), the auto or flyback coil, the diode ECG-513, make the spark gap assembly, the capacitors, make the Tesla coil assembly. Don't forget the switch and the external ground buss. There are two tuning knobs extruding from the briefcase: the variable 10k resistor from the 555 timer circuit, and the nylon bolt to vary the spark gap assembly.

DISCUSSION OF COMPONENTS:

The battery may be any source of electricity. I use a 12 volt lantern battery and get good results; two six volt lantern batteries in series work even better. An electric model airplane motor may be turned by a gas model airplane motor and made to run as a generator of dc @ 6-12 volts, 20 to 30 amperes.

The timer circuit turns the electricity on and then off at variable frequency; this drives the first transformer: the auto ignition coil or tv flyback transformer. The NE555 chip is a popular integrated circuit- I suggest a book: 555 Timer Applications Sourcebook, With Experiments by Howard Berlin. Put the timer circuit together on a small pc board with copper on the back, you can get pc boards at Radio Shack- ask them for 276-168 pc board. Don't buy your 555 timer chip from Radio Shack, theirs are for low power only. Get some NE555's with base sockets for them at your favorite electronic surplus store. Assemble the small components on the pc board with the chip Get two radio frequency choke coils with a ferrite core, you will see the bright copper wire exposed on these choke coils and they look neat. They do nothing but protect the 555 integrated circuit from any sudden high voltage overloads that could destroy the chip. The npn transistor (2N3055) may require a heat sink to keep it cool; it handles all of the current from the battery. You can hook extra transistors in parallel to increase the current carrying capabilities of the circuit. So far, I have my one transistor run cold with a heat sink to drive this MWO power supply.

Be sure to use copper spark plug wire on the diode connections, not radio suppressor "wire".

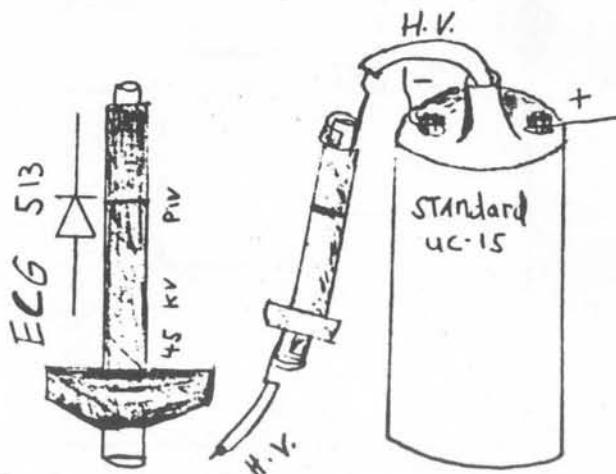

The auto ignition coil is more satisfactory than the model T Ford coil used by Bob Beck. Ask for a standard high energy ignition coil with a 12 volt input. When the person behind the counter asks you what you want it for, answer a Cadillac and then look in his book and find the highest output in volts for the different model years listed. Then buy a non-Cadillac part because it's cheaper; but get the most powerful coil if you can. I like the Standard Plus UC-15. And don't forget that we can use a flyback transformer from a color television. Wrap about 50 turns of #22 or smaller insulated wire around the exposed ferrite opposite the factory winding. Feed in the output of the 555 timer circuit to the ends of this 50 or so turn winding; the hv lead of the flyback should yield a 1" spark easily. We can vary the frequency output of the hv in the auto coil or flyback transformer. These flybacks are very light weight compared to the auto coil.

The diode is an interesting component; diodes used to be called detectors of Hertzian waves. They were used in homemade radio receivers in the form of natural crystals such as quartz, germanium and silicon. Then Lee DeForest or somebody invented the vacuum tube which did the job better. Then Professor Shockley, and Mr. Moray discovered things can be done still better back in the solid state. Germanium is prime diode material, we use a monster called the ECG-513, able to withstand 45KV before failing. It would be hard to make a diode this good ourselves. The diode polarizes the electricity coming from the hv. transformer. The diode takes out stray ac currents that seem to be present and insures that we have pure dc electricity at pulsed high voltage. When making diode connections, use copper wire made for spark plugs, don't use radio suppressor wire- it doesn't have any wire in there, it's just fiber and carbon !

A suitable spark gap may be made from a spark plug. When a fixed spark gap will do, a spark plug is hard to beat. Spark gaps need to be resistant to high temperatures. I like the variable spark gap because it lets us tune the power supply while it is in operation. The wider the gap, the slower the frequency of the spark jumping the gap; the closer the gap, the faster the frequency of spark jumping the gap.

Walk in to the auto parts store counter and tell them you want a set of points for a 1950 Chevy six cylinder. Get two sets of these points. Cut the spring action point assembly in two with a hacksaw. Make the cut to separate the assembly where the points normally meet. Bend the non-moveable point so that it faces the other way and line it up to where you want it to meet the spring loaded moveable point. The tungsten points must be closer to each other than to any opposite part of the spark gap assembly. Use nylon nuts and bolts to make a tuning shaft- we don't want any shocks in the spark gap tuning knob ! File down any sharp metal edges on spark gap where cut was made. Put a bushing in the side wall of the briefcase where the nylon bolt tuning shaft extrudes, make it a nylon bushing. Now we can tune the circuit in two ways: first at the 555 timer circuit and second at the spark gap.

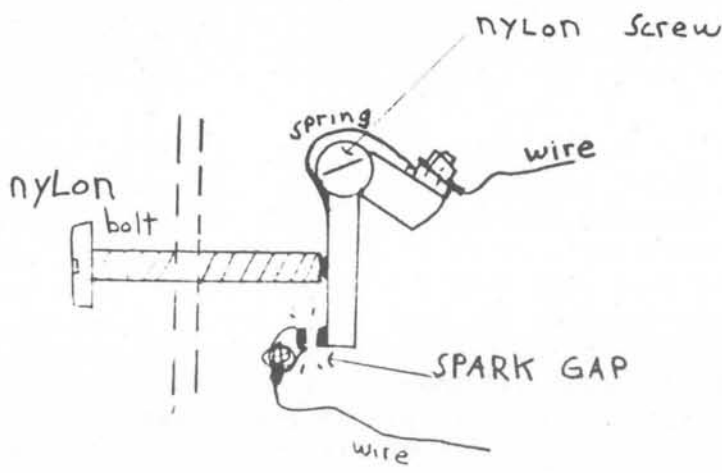

SPARK GAP ASSEMBLY:

Insulate the base of the spark gap assembly. Look for corona discharge to travel through the plywood or other material that spark gap assembly is mounted on.

The pressure of the high voltage causes breakdown of the insulation strength of the dielectric, the air. We vary the gap from millimeters to centimeters. When the gap is set at such a distance that the spark does not have enough moxie to jump, we can still control the frequency at the 555 timer circuit. We can hear the circuit and listen to the corona discharge as it hisses in the gap. We hear from lowest to highest in the audible range.

CAPACITORS:

Capacitors are where it's at for getting power. Capacitors allegedly store the electricity. We credit the community in Leyden Holland in 1745 for experimenting with electricity and the devices that were then called condensers of electricity.

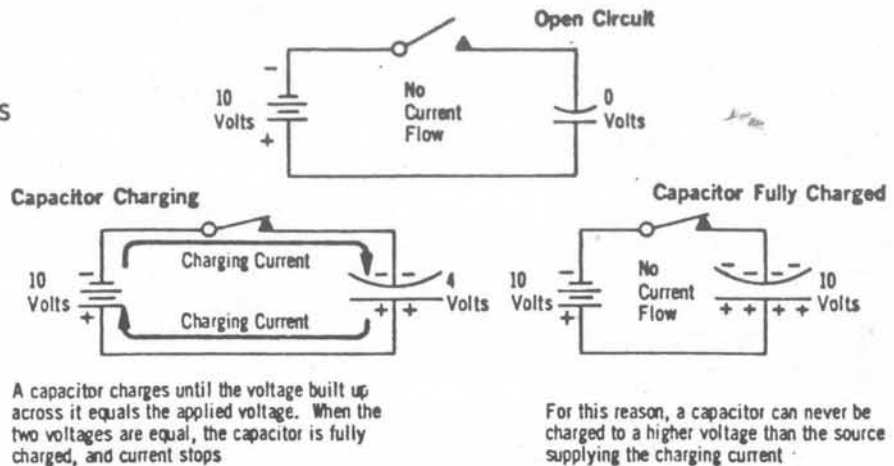

The discharge is where we get back all the electricity we have been storing up- and we get it all at once !

The longer the time period between discharges, the greater the amount of stored electricity in the capacitors.

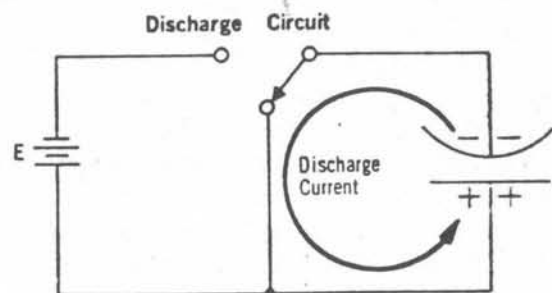

We buy these things at the store or make them ourselves; I like store bought Sprague capacitors, style 418 "doorknob"- rated at 20kv, 30kv, & 40kv @ .005 mfd. It is easy to round up some 2500 wvdc caps with a 5000 volt rating that have .005 mfd of capacitance. Ceramic capacitors are the best kind. Try to avoid any oil filled capacitors made in the form of glass cylinders in different colors. These oil filled glass caps tend to break and the oil is pcb and toxic. In the bins at the surplus electronic stores, don't get any of the broken ones on you. If you can't find any ceramic caps, then oil filled will have to do - just don't break them.

String together the capacitors in series parallel arrangements to arrive at the desired values. Series connections add the voltage and lessen the capacitance. Thus four 5000 volt caps yield a 20,000 volt capacitor. Always match the caps that you string together from exactly the same kind when getting up to high voltages in capacitors. Never use a few stray caps of a different size or voltage or capacity. Four 5000 volt caps @.005 mfd yields 20,000 volts @.00125 mfd. We nearly always string the caps in series to get higher voltages, but with series parallel connections, any value of voltage (up to a limit) and capacitance may be produced. A word to remember: capacitors store electricity and will shock you unless a grounded high voltage probe is used to safely discharge the circuit. The powerful capacitors that we are discussing can retain large amounts of electricity even after the circuit is turned off.

THE TESLA COIL:

And now the Tesla coil - so very much has been bandied about the properties of Tesla's most famous invention that we needn't discuss Mr. Tesla. Suffice it to say that we make a Tesla coil in the recipe given by Mr. Beck in the book, The Lakhovsky MWO, and leave it at that. Make the secondary a little long and test it under power; use the grounded high voltage probe to see where the secondary yields the longest spark, then mark the spot; cut and finish the end of Tesla coil secondary winding.

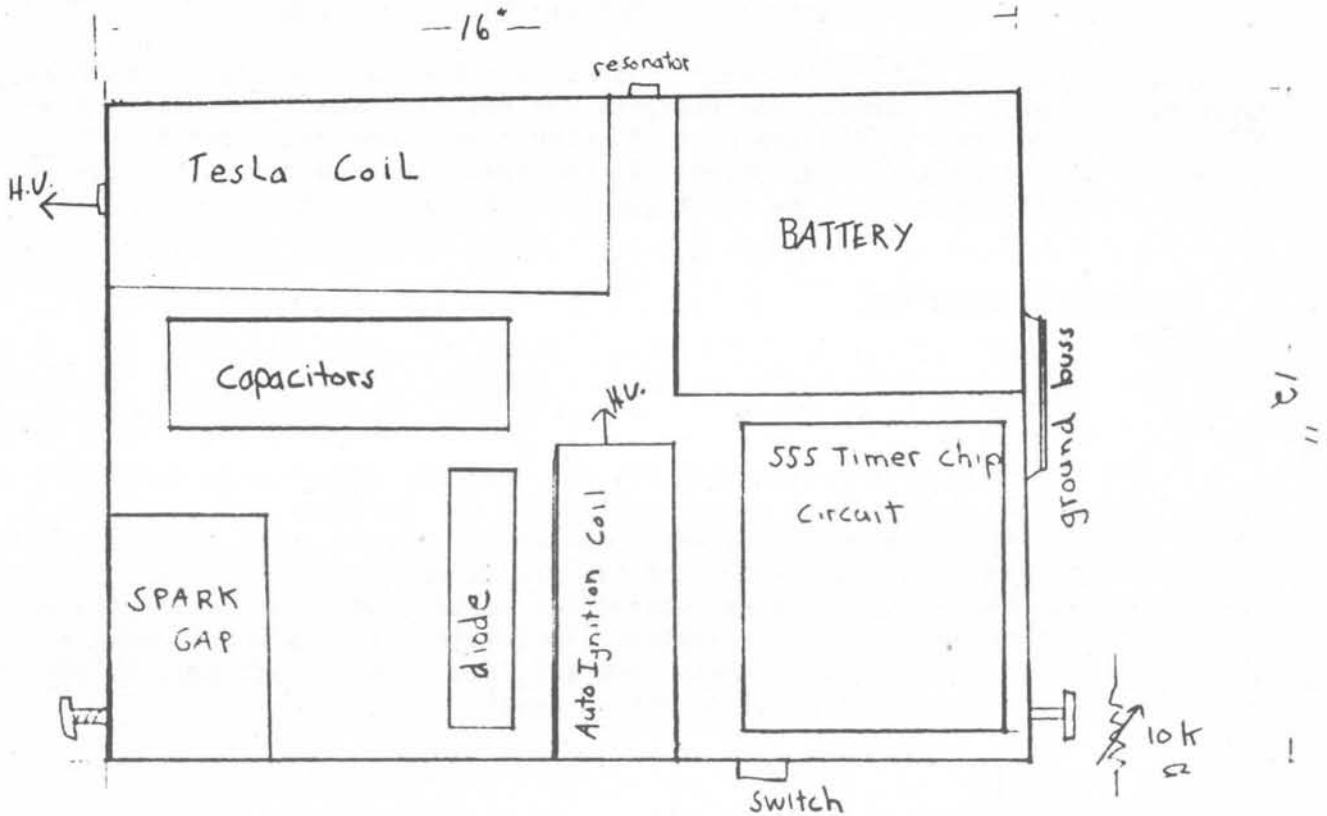

I like acrylic (Plexiglas), acrylic tube, acrylic sheet, plastic water pipe and other glueable plastic to make my Tesla coils from. Acrylic may be scored with a special knife and then broken or snapped apart into desired shapes. Gently heating acrylic in an oven makes it possible to bend acrylic easily. For tubes and pipes, a hacksaw works well; use a pipe cutter to to score acrylic tube or plastic pipe before cutting with hacksaw. Primary winding of Tesla coil: 2½" od. with 16 turns of #18 insulated solid wire. Secondary winding of Tesla coil is 1¼" od. with 4¼" of #30 fine enameled copper wire. Make both tubes holding the windings at same length- about six inches long. Acrylic is clear and permits visual inspection of interior of Tesla coil. Line up the two tubes or pieces of plastic pipe and glue them in a plastic or acrylic frame. Make the Tesla coil as a modular unit with easy connections to the rest of circuit.

SWITCH AND GROUND BUSS:

The switch can really be anything but make it safe because the hand is brought nearest the operating circuit when turning it off. I like a key style ignition switch from a car; just get a key switch and mount it through the front of the briefcase.

The external ground buss is pretty important if anything ever goes wrong. The negative side of the battery is at ground potential in this circuit. I like to put a piece of rebar in the backyard near the kitchen window and run in an extension cord with a big alligator clip to connect to the briefcase sized power supply. Though it is safe to run the box without the ground, it is handy to connect a test wire to the grounded buss and use the test wire as a grounded high voltage probe to poke around in the operating circuit and to discharge capacitors with after turning unit off. Cold water pipes made from copper, iron or steel are an acceptable ground. Do not use gas pipes by mistake.

The two tuning knobs will be the 555 circuit knob on the right and spark gap knob on the left. By careful observation, the resonate condition of the circuit will be noticed when tuning the circuit under power. One knob controls the frequency of the pulses of dc going into the first transformer. The other knob controls the distance that the spark jumps in the spark gap.

DARKROOM OBSERVATION:

In the darkroom observation session, let the eyes accustom to darkness and have a flashlight handy. Turn the circuit on in the darkness and be prepared to turn it off in the darkness as well - potential danger here, reaching into an operating circuit in the dark. Look for places where the corona may be seen, then insulate those places; vinyl tubing can be slit up one side and fitted around leaking connections. High voltage electricity is like high pressure steam: both like to leak. Air breaks down and lets electricity pass at 10kv to 30kv. Corona leaks rob the final output of power.

Study the output of Tesla coil and notice the effect from turning the frequency controls. Connect the MWO antenna. (Do this with circuit off). Again, observe the sparks jumping gaps on the antenna and also look for brush discharge from the antenna. This is why we eliminated stray corona discharge from within the circuit, so that the power is concentrated in the discharge of the radiant MWO antenna.

The subject sits between the radiant MWO antenna on one side and the resonant MWO antenna on her other side. Certainly notice and record any subjective impressions that subject communicates to the experimenters.

MWO POWER SUPPLY - MORE INFORMATION:

Use this MWO Power Supply from Super Science to test your favorite theories. Remember, hardware counts especially when you don't have lots of phd to back up the hot air or papers on the subject. Tesla, ion wind, ELF generators, Kirlian photography, Biefeld-Brown effects- this unit can do it. For more information about availability of components, plans, kits, prices and complete assembled briefcase units - just write to Klark Kent c/o Super Science, POB 392, Dayton Ohio 45409. Or call at 513-435-6138.

WILHELM REICH M.D.

Lets not forget that the discoverer of the life energy was Wilhelm Reich M.D. Since we are of Western civilization, from the Urals to Atlantic, we look to our own culture for our orientation to life. In our culture, Reich was the one who discovered the "force" first as human sexuality as a protege of Freud. Then Reich observed the energy in single celled organisms. Atmospheric phenomena such as aurora borealis, hurricanes, West to East weather flow and increase of drought were observed and recorded by Reich. Using the most modern gadgetry medical science could provide, Reich spent a career laying the framework for us to build on in the study of life energy.

MWO PHOTOS

Here are a couple of the many photos supplied to Borderland by Klark of his work. His experimental units are neat and reliable and are available for \$500 including shipping costs. The price includes the high frequency unit and a pair of MWO antennas.

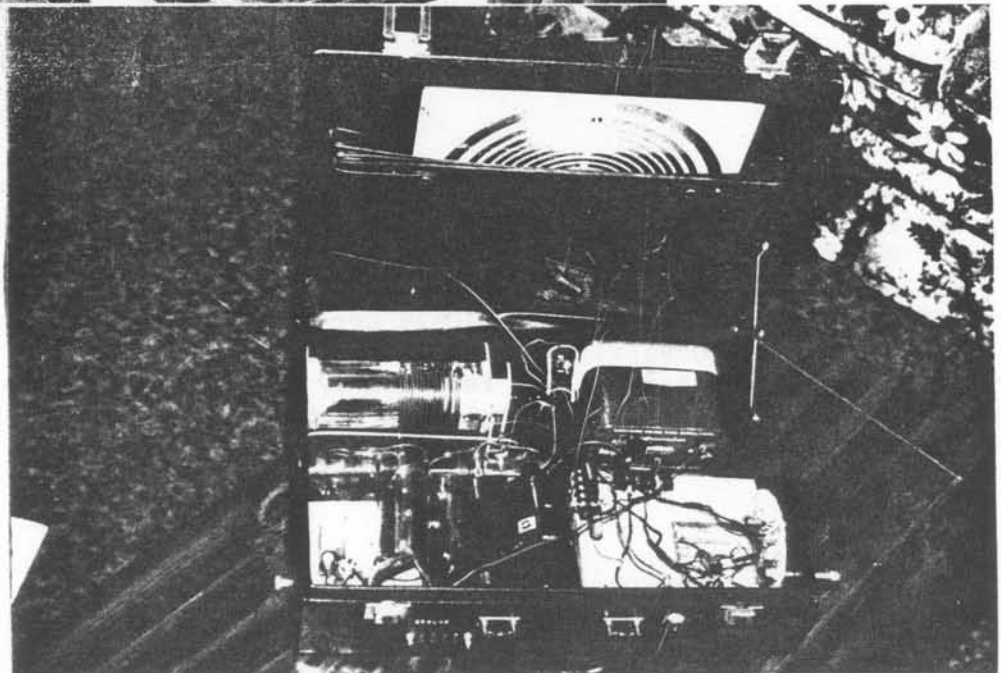
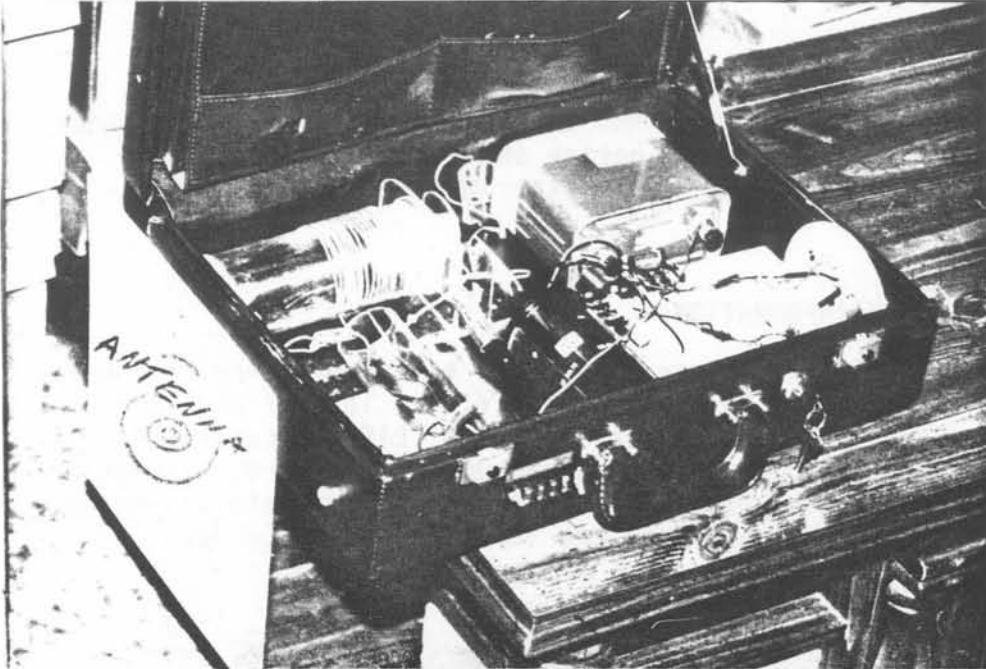

THE LAKHOVSKY MULTI-WAVE OSCILLATOR This is the BSRF publication which is the basis for Mr. Kent's updated information. This book is essential to anyone experimenting in this area of high-frequency phenomenon. (BSRA #29).....\$5.50 plus P & H

CLIPS, QUOTES & COMMENTS —

YOUR NEW DIRECTOR

Riley Hansard Crabb has been the director of Borderland Sciences Research Foundation since taking over from Meade Layne in 1959. His accomplishments include the carrying on of Meade's work in investigating the borders between the seen and unseen worlds. Riley has written, lectured and published on a variety of subjects of great importance to thinking people everywhere. From Flying Saucers to the Western Mystery Tradition and through free energy, Nikola Tesla, the earth grid system and the attacks on our freedom by MIRO (Military Industrial Religious Oligarchy). His accomplishments in this arena are legion and after 26 years at the helm he has opted for independent study as a world traveler.

To insure the continuation and expansion of his work and the work of our Foundation he has asked me to take over the directorship of BSRF. My name is Thomas Maxwell Thompson. I was born Thomas J. Brown and changed my name through the years as I grew and changed. I came to Riley about four years ago to ask advice, buy his literature and find out what was really happening in the world. He has been a guide and a friend and I gladly take up the task he has put before me. From the rich 40 year past of Borderland I look to the future as the third director of the Foundation.

HOW I VIEW THE WORLD

Many of you reading this will be wondering about my background. I am a person who does not judge people by the amount of alphabet soup dragging after their name. I dropped out of school after the 11th grade because I didn't care for the teachings or the manner of teachings. Since then I have been reading constantly on all manner of subjects from radionics, UFOs, Nikola Tesla, Western and Eastern Mystery Traditions etc. I had bought and read most of Riley's books before taking over here. The Directorship of BSRF will be used to enunciate my view of the world and how we can learn and grow constantly through our life.

The universe is a living entity. Life is a spontaneous universal phenomena and not regulated by scientific or religious dogma. I hope to be an iconoclast to those who cannot grasp the concepts of living matter. The files of Borderland are replete with evidence supporting this and I will publish and experiment along these lines. In this vein some early publications of Meade Layne will be brought to light and republished. These concern ether physics and the spontaneous formation of life from inorganic material. Orthodox science does not accept what it cannot measure or understand. Orthodox religion is locked into the view of the universe that supports its stranglehold on our souls and pocket-books. Both are generally detrimental to our evolution and life.

To learn and grow is the essence of life and as I learn and grow I will publish the results. I have been in touch with some very interesting people along the way and I will publish a variety of information and authors. The rest of this Clips, Quotes and Comments section will be used to cover some of the upcoming work and to keep a current eye on the Borderlands of reality and perception that we meet each day.

NEWTON'S LAWS ARE FULL OF FLAWS

Researcher Al Snyder of the Snyder Institute of Research in Redondo Beach California has written at least five books covering errors in present scientific thinking. There are many existing MYTHS 'created' by today's 'scientists', who are constantly devising ways and means to make everything difficult and confusing, to keep this information from you and I. As a consequence, because of their pedantry, because their 'knowledge' is all obtained from books learning -- they have fouled up science -- so that any PG (Potential Genius) simply avoids these exciting subjects, simply because they don't make "goches" (Al's term for Good Old Common Horse Sense).

As a consequence the orthodox scientists have cost you and I, and the other taxpayers, billions of dollars in extra taxes. Al Snyder is boldly coming to the forefront, to make an expose of all this ignorance and corruption. Al was born to and raised by deaf mute parents so he early learned how to communicate using simplified methods -- and he guarantees that YOU, or any other average person can be developed into a 'PG'.

Al has also developed a method of using children's play blocks to actually construct and build mathematical equations, which will enable anyone to actually see and understand what math is all about.

Scientific magazines and periodicals, schools, etc are not interested in Snyder's simplified methods. Would a magician be interested in someone that was going to expose their magic? Al delights in pointing out scientific 'fudge-factors' used to make equations fit the scientific view.

SCIENTIFIC IDIOCY

We have been taught that the Gulf Stream heats Europe by its carrying heat up from the Caribbean, past the east coast of the US and on to Europe. In Al's book MOON THE WEATHER GOD he points out how ridiculous this is. He notes how in 1985 'scientists' discovered that the Gulf Stream merges and mixes with the iceberg infested waters of the Labrador Current. If anything, the Gulf Stream would be better at freezing Europe. The book covers the correct mechanism of heating Europe, with tidal flows starting at Capetown, South Africa. This is just one of the many areas covered in Al Snyder's work. The theory of the tides as decreed by Newton falls far short of reality. Al applies GOCHES and comes up with the answer.

Sir Isaac Newton stated that the Earth has 2 simultaneous HIGH TIDES. One facing the Moon and the other on the opposite side. If this were so then the HIGH TIDES would have to travel about 1,000 miles per hour, in order to keep pace with the Moon. Could you imagine being on a small island in the Pacific and having this HIGH TIDE approach you at a much faster rate than hurricane speeds, and with far more force. The island (and you) would certainly not survive, but this theory is still taught in our centers of 'higher' learning. Al directs us to pick up a tide book. There can be a high tide on one side of the Panama Canal and a low tide on the other. There can be several high tides along the coast of Africa & Europe with an equal number of low tides inbetween. This is the real reason for Europe's warmer climate.

Al notified NASA of his work, as a patriotic American wanting to help, and he was rewarded with a raid by the Secret Service! I salute Al for his efforts and will be carrying more of his work in the future. He postulates a hollow earth with a vacuum in the center, (I agree partially with you on that one Al) and generally gives out good knowledge to anyone who wants to truly understand the mechanics of our universe.

The five books published by the Snyder Institute of Research are NEWTON'S LAWS ARE FULL OF FLAWS; MOON THE WEATHER GOD; SATAN'S SAUNA And The DEVIL'S TRIANGLE; HOW (Y)OUR UNIVERSE WORKS; and MATHEMAGIC FOR IDIOTS & GENIUSES. The first four are \$9.95 (paperback) and MATHEMAGIC is \$14.95 (hardback). Prices include postage and tax. Write to the Snyder Institute of Research; 508 No. Pacific Coast Highway; Redondo Beach, CA 90277. Become a 'PG'.

NEW LIGHT ON THE CHANGING FACE OF MARS

In the Los Angeles Times, October 9, 1985 was an article titled "Mars Was - and Is - Wetter Than Previously Thought". In the article it is noted that the red planet may have 10 times more water than previously thought. It is now supposedly trapped in the polar caps or in underground caverns. In the book "Unusual Martian Surface Features" by Vincent Di Pietro and Gregory Molenaar we find a photograph of a geyser or waterspout on the Martian surface. This is along with evidence of intelligent construction on the surface of the planet. If I stop and think for a minute I can recall a different story about the planet coming from the scientific world.

In the January 1977 National Geographic there is an article - MARS - AS VIKING SEES IT. In this article we see how Mars is a lifeless desert. Evidence is shown of water erosion in the past, and of course no evidence of life was found whatsoever. This is reiterated in the LA Times article. "No evidence of life - or even of the basic organic building blocks of life - was discovered by either Viking probe in the late 1970s and early '80s". We shall see that nothing could be further from the truth!

LIFE FROM INORGANIC MATERIAL

Meade Layne published a small booklet titled 'The Morley-Martin Experiments and The Experiments of Dr. Charles W. Littlefield' in the early years of Borderland. This book describes the experiments of Morley-Martin, Littlefield and Andrew Crosse in the formation of organic compounds from inorganic material.

Andrew Crosse is perhaps the best known of these three. He succeeded in his experiments by having small spiders form from a piece of porous red oxide of iron from Vesuvius. Basically he electrified the rock and dripped a solution of powdered black flint and carbonate of potassa in water and hydrochloric acid over it. This experiment was repeated with variations and life was produced on several occasions.

Morley-Martin treated Azoic rock (pre-fossil) to intense heat and evaporation. He succeeded in discovering microscopic fishes, insects, plants, etc. on his evaporation trays. "Under the enlargement of the microscope globules were seen taking shape within the protoplasm and forming vertebrae which then elongated into a spinal column in which the ribs were inserted; then came the outlines of the limbs or claws, the head, and the eyes. These transformations are normally slow and require several days, but at times they took place under the eyes of the observer. One crustacean, for example, having developed its legs, walked off the field of the microscope."

Littlefield experimented with the evaporations of tissue salts and directed mental energy. One facet of his experiments showed that organic tissue can form from the inorganic cell salts. He furthered this work by showing that visualization of a spiritual principal would cause the crystalization to form a sympathetic picture. He photographed crystalizations of books, thrones, doves, serpents, women, pyramids, the Rosy Cross, etc.

The combination of these three men's work plainly shows the misdirection of our scientists investigating the possibilities of life on the Moon and Mars. As long as science treats matter as dead it will never find life. Morley-Martin proved that there is no death - only latency!

GREEN AREAS BETOKEN MARTIAN LIFE

"Apparently a vast area of desert can spring into sudden fertility, if in fact - as we believe - the darkening is due to the growth of plant life. Like vegetation on earth, these green areas turn gray, brown, or red when the Martian fall and winter come.

"Biologists suggest that this life may be akin to lichens, which flourish even on our mountaintops. To shed further light on the subject, efforts may soon be made to grow such plants in the laboratory under the physical and chemical conditions that are thought to exist on Mars.

A Gallery of Mars Portraits Reveals a Texas-size Green Patch Sprouting from the Desert

Dark areas are permanent features of the Martian scene. In the past they have varied only in size and intensity. In 1954, however, the author witnessed the growth of a new dark patch, indicating that such areas could spring up anywhere in the desert.

Mars in 1907 (opposite page) showed the lower hemisphere largely desert (white space), its moisture locked in the polar icecap. A 1939 picture (left, above) revealed a burgeoning of the Thoth Canal (lower right), together with the extension of a green area, never seen before, across the equator into the desert. By 1954 (right) the new green area covered some 200,000 square miles.

"Such green areas bear eloquent testimony to the fact that Mars is not a dead world. In fact, all the various Martian markings betoken that it is a living planet, that life of some sort exists there. If this were not so, the winds of Mars would long ago have scattered the dust and sands everywhere, rendering the whole surface the same uniform tint. Obviously it is the growing of something on, or out of, the surface which prevents Mars from becoming featureless forever."

NATIONAL GEOGRAPHIC, September 1955

What changed between 1955 and 1977? Did the planet change or did the method of reporting to the public change? Oftentimes the pictures of National Geographic tell a different story than the text. To do a little home research, look up the issues dealing with the lunar landings. Many anomalies can be found in the pictures. Dome buildings, boulders that roll uphill, and other interesting phenomenon await anyone with a keen eye.

PSYCHOTRONICS CRUISE

The Colorado Psychotronics Ass. is sponsoring a scientific research seminar combined with a 7-day Caribbean cruise. It will be from April 5-12, 1986 starting in San Juan, Puerto Rico and going through Curacao, Caracas, Grenada, Martinique and St. Thomas. Dr. Andrija Puharich is the keynote speaker on the cruise and also Dr. Bruce Lipton who has done some fascinating research on communication at the cellular level.

If you think you could adjust to a few hours (10-12) of lecture on some of the latest research in various heal-

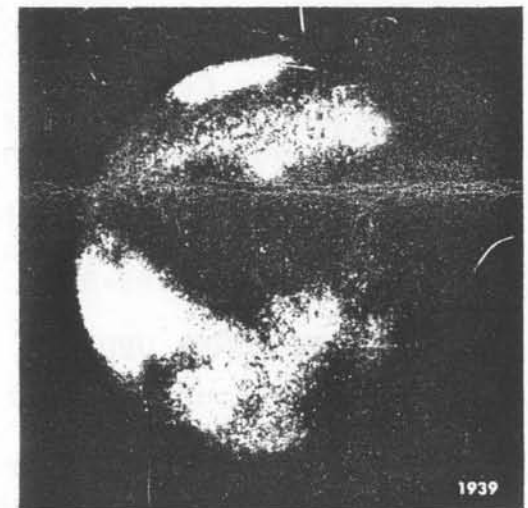
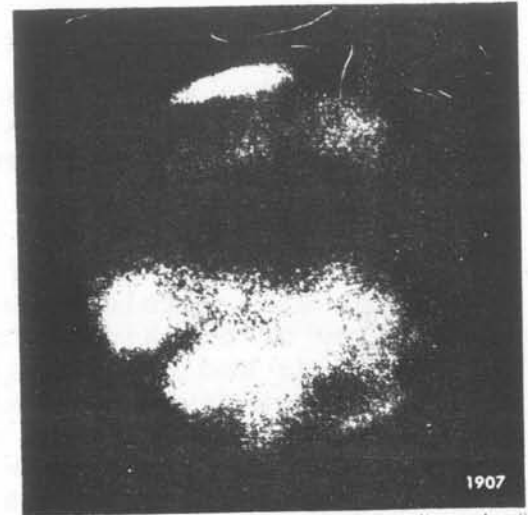

ing methods, plus sail from island to island, explore white tropical beaches, see the vibrant colors, flowers, music and people of these lands, tropical sunsets at sea - Feast - Dance - Gamble - Relax and Learn, then contact Dean & Phyllis Stonier, 3273 E. 119th Pl., Thornton CA 80233, (303) 452-9300.

THE FURTHER ADVENTURES OF ELAINE PEICK

Before you go dashing off to the Caribbean for a cruise you may want to join BSR Associate Elaine Peick on a journey to study the mysteries of ancient and modern Egypt. This trip will span 18 days - from March 1st to 18th, 1986.

"You are invited to share in an exciting and unforgettable journey to the Land of the Pharaohs. The mysteries of ancient Egypt will unfold as we journey along the Nile. Visits to the Valley of the Kings, Luxor, Aswan, Tel el Amarna, Sakkara, the Pyramids and Sphinx will leave us all with wonderful memories. Enjoy a 4-day cruise along the life-giving Nile to special temples. Many sights have been added that I do not usually include on my Egyptian trips. This will be my 8th time to take groups to Egypt as I have taken groups overseas several times each year, specializing in Egypt.

"I have many Egyptian friends and my group will have dinner in the home of one family. I have taught Meditation and Metaphysics at Palomar College (San Diego County, CA) for nine years, hold classes in my home and lectures in the U.S., overseas and on cruise ships. On this trip there will be times of sharing, times to experience the energies of the special temples and meditations in sacred spots. Many places will be visited that are not seen by the average tourist." Elaine Peick, 23852 Wardlow Circle, Laguna Niguel CA 92677, (714) 495-0533

RAINBOW TONER UPDATE

"In your publication 'The Heart to Heart Transplant' (BSRA #28), plans are given for the Rainbow Color Toner. Since Model A ignition coils are not easy to find, and quite expensive, can other newer coils be used instead? Or, is there something unique about the Model A coils that is not available in new coils?"

L.K. Granger Indiana

This and other letters come in here at headquarters asking about the Rainbow Toner. The Toner is a radionic device for pulling in the healing color radiations from the 12 constellations of the Zodiac. Building instructions are included in the above mentioned book and in our publication 'RADIONICS - New Age Science of Healing' (BSRA #33-A). The Model A coils needed for construction along the lines in the books are available from J.C. Whitney, 1917-19 Archer Ave, Chicago IL 60680. The following pages are an updated schematic that I found in the files. Many thanks to the author, known at present only as B.S.

Subject: RAINBOW TONER

After having constructed the Rainbow Toner, as per the original instructions, I found it to be a very powerful tool, but not specific enough for my purpose. I therefore built into the circuit a series of 10-position rotary switches with fixed resistors. This allowed me to tune the R.T. to specific values, including those of metals, precious stones, colors and even homeopathic remedies.

In testing the outcome, I discovered, however, the R.T. to be an extremely dangerous instrument. With or without the resistors, it is capable of transmitting influences from the so-called "Lower Astral" level, which super-impose themselves on the desired etheric waves. This means that obsessive and possessive entities can, and actually do, use the etheric energies as a carrier-wave through which they attack the patient.

As you undoubtedly know, by some one inexperienced in these matters, such parasitic entities are not immediately perceived and seldom recognized for what they are. They therefore can inflict substantial and eventually permanent damage to the victim. While trying the various colors on myself, I noticed this fairly powerful effect to my great surprise. I then had the output from the R.T. checked by two independent researchers, without telling them of my findings. Both separately confirmed them.

Obviously, these superimposed influences had to be filtered out. We succeeded by placing a series of capacitors in the circuit, to the value of 714 uf exactly. This cut the possibility of transmission to about 1%. A sterling silver plate at the output end was also found to be of help, cutting the last percent to virtually zero, but without affecting the desirable etheric energy flow.

Again we thoroughly checked the results and found that within the range of the R.T. there still remained a noxious radiation, ranging from an estimated 5% to 40%, depending on the receptivity of the patient. Although far less dangerous than the Lower Astral influences, this radiation could nevertheless prove to be quite harmful under certain conditions. Unless a solution was found, the R.T. had to be written off for healing purposes.

I finally discovered the solution in Patrick Flanagan's article on "TOPOLOGICAL ELECTRONICS" (Psychic Observer, Vol.39, No.1) which explains the difference between the effects of dextro-rotary and levo-rotary radiations (right-hand turning and left-hand turning radiations). The first kind are detrimental to the organism whereas the latter have a strengthening effect. Obviously the Rainbow Toner was, as such, not selective in these matters and able to transmit both kinds.

Since, on a microscopic scale, the human body is supposed to use möbius-coil type nerve configurations to maintain the levo-active (left-hand turning) condition, I experimented with möbius loops, made from flat sheet-metal, which were totally useless. Then I hit the perfect solution: a möbius coil, made from insulated wire. This, built into the circuit, made the previously random rotation uniformly spin in the desired levo-active sense. It does in no way diminish the power of the output, while it brings the possibility of adverse effects back to practically nil.

It must be noted that the value of 714 uf was calculated for the apparatus we were using, with Ford Motorcraft DG-2, 6 volt coils. (12 Volt coils are far less effective). For different type 6 v coils, this value should probably be adjusted.

The L.H. turning möbius coil was made from 24 gauge magnet wire, wound and glued on a preformed cardboard model. Approx. 30 turns, one besides the other, on a form of 3" or 4" diameter was found to do the job well enough. A möbius loop is, of course, made by giving a strip of material one turn before joining the ends together. Critical is the sense in which it is turned. See sketch.

Following is a diagram of the arrangement which we have found to be the most beneficial and versatile.

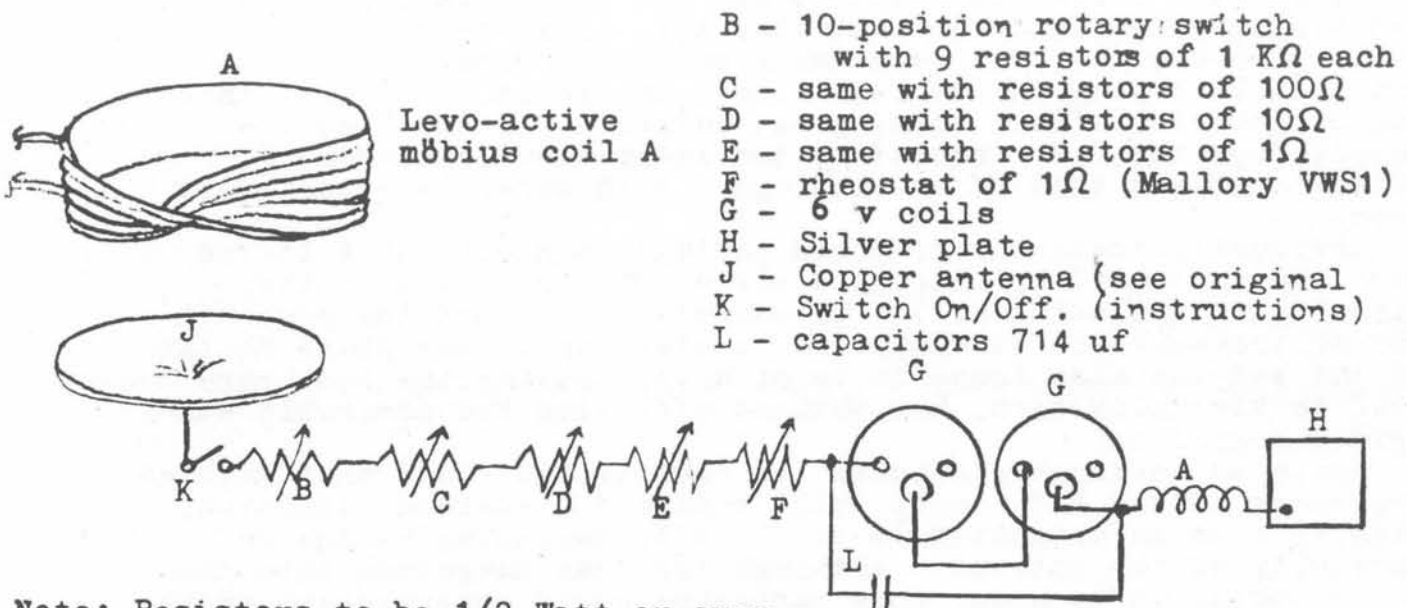

Note: Resistors to be 1/2 Watt or over.

We are dealing with an energy very different from electricity, which is flowing through the circuit more or less like sirup. Too fine gauge wiring would unnecessarily obstruct the flow.

Following are a few examples of values, as we found them to apply, but which may be slightly different for similar units, containing slightly different components. (Figures in 1/10 of an Ohm)

STONES:

- Diamond - 9266.1
- Tourmaline:
- " red - 4056.4
- " green - 4060.4
- Different kinds of clear quartz: from 3570.5 to 3577.5
- Amazonite - 3242.3
- Pearls - 2889.0

Some homeopathic remedies:

- Melitagrimum - 1033.6
- Argentum Nitricum - 1261.3 and 1265.6
- Aluminium Muriaticum - 1125.7

Finding precise values takes checking, rechecking and an enormous amount of patience. But values found prove to be constant, unaffected by time of day or by the weather conditions.

B. S.

LETTER FROM RILEY

"Here's another revelation from 'Sky Crash, A Cosmic Conspiracy' by Brenda Butler, Dot Street and Jenny Randles. It concerns Lord Peter Hill-Norton, enthusiastic supporter of the Earl of Clancarty and his All-Party UFO Group in the House of Lords. Jenny met Lord Hill-Norton when she gave a talk to the Study Group just a few days before the Rendlesham Forest UFO crash described in her book, Dec. 27, 1980.

"Lord Hill-Norton had been Admiral-of-the-Fleet and Chief of Staff of England's Ministry of Defense (MOD). He told her an amazing thing. 'While at the MOD nobody had ever intimated to him that UFOs were a serious matter, and he never had the slightest conception of the strength of the evidence.'

"Apparently there are several layers of government above England's MOD and it was decided that the head of MOD had no 'need to know' about the reality of Flying Saucers. It was only after leaving MOD and that position of power 'that he became awakened to the enormity of the problem and thus that a very high level of cover-up must be in operation if it totally by-passed him...

" 'Jenny asked the Admiral why he thought there was a cover-up. And he told her that he believed the amazing technology the UFOs seemed to possess had to be a prime military target for any power. He was particularly disturbed by the anti radar capabilities UFOs seemed to display. Such matters threatened the security of the world if somebody else got to them first. So there had to be a big cover-up. It was indeed curious that a few days later whatever it was that entered Rendlesham Forest did so apparently in spite of the superb radar net that surrounds the area...'

"President Carter became aware of the 'high level cover-up' when he was forced to acquiesce to the Flying Saucer 'silence policy' while in office. It happened to Senator Barry Goldwater when he tried to get into Hanger 18 at Wright Field, Dayton Ohio to see the humanoid bodies and crashed UFO supposed to be stored there. He had no 'need to know' even though he held the rank of Brigadier General in the USAF.

"MIRO, the Military, Industrial, Religious Oligarchy that runs America must be closely allied with the MIROs that run the other leading nations of the world and thus we do have a secret world government.

"Met a US Navy gal here at the Lodge yesterday, on her way back to her duty station at North West Cape. Did not learn much except that there is a huge Tesla Transmitter there." Sincerely, Riley Crabb, Perth Australia.

NO NEED TO KNOW

Thank you Riley for this important information gleaned on your world travels. Apparently the American public has no need to know of the manipulations of our planet by unknown forces.

We have no need to know much of what happens in this world, or so it would seem by watching the network news. A prime example is the recent explosion of the Nevado Del Ruiz volcano in Columbia. Not one news service covered the full range of events. All we heard of was the tales of tragedy and heroes. One network news station also covered the eruptions of a volcano on Hawaii the same day. Prognosis: not related to the Columbian eruption. Another network carried the story of an eruption in Indonesia on the same day. Prognosis: not related to the Columbian eruption. I suppose I should assume that the Alaskan earthquake (5.7 on the Richter scale) was not connected either. That one got seven lines buried in the back of the LA Times.

What a coincidence that all these earth movements can happen at about the same time with out being connected to one another. It probably follows that the Mexican earthquake was not connected to the French nuclear tests in the South Pacific. And none of these events should be taken as portents of future earth movements.

It is a shame that our sciences, religions and politics are so disconnected from reality that mention of a fact not in someones belief system is enough to make serious enemies. Our universe functions on the free flow of energy, physical, mental or spiritual. Wherever there are energy blocks disease manifests. This can be seen by the congestion in our bodies and in our polluted waterways. The function of Borderland Sciences is to allow the free flow of energy and information to manifest. Perhaps we can get a few people to think out there.

Most of you reading this are members of the Foundation, some of you going back to the days of Meade Layne. You have a need and yearning to know what is going on around you. Out of 4.5 billion people on earth only 450 subscribe to this Journal. That leaves a large number of people who need to know. See if you can't wake a few of them up!

LIVING IN THE DARK AGES

Ralph R. Hovnanian has donated a box of his book 'Medical Dark Ages - Circa 1984 or Cancer Alternative Therapies Cure Rates' to BSRF. This book is a well documented file on various cancer treatments and their effects. It also covers many instances of the suppression of these alternative therapies. This book is an indictment of medical and business monopolies who are constanly manipulating us. There are no wild claims. Everything listed has its reference given. I haven't yet had the time to read it but a preliminary scan shows it to be a book well worth getting if you have that 'need to know'. A \$9.00 donation to Borderland will bring you a copy of this book. Part of what you send will be forwarded to the author. Quantities of this book can be gotten from: Ralph R. Hovnanian, Medical Dark Ages, c/o 2128 Prospect Ave., Evanston IL 60201, phone (312) 869-4346. Excerpts from this book will appear in future issues of this journal.

THE LINK

R. Murray Denning, author of 'My Search For Radionic Truths' has developed a complete radionic system for the serious practitioner. This system is the result of many years of hard work and study in the field of radionic therapy.

The 'Link' system consists of five units - Diagnostic, Treatment, Detector, Meter and Mains Supply (power).

If you are seriously interested in getting a complete radionic system you can contact Mr. Denning at: 26 Wey Lane, Chesham, Bucks HP5 1JH, ENGLAND.

Mr. Denning is also the author of several books dealing with the work of the prolific Ruth Drown. He can be contacted concerning these also. We have purchased a small amount of his 'Truths' book for those who would like to have a copy after reading the review in the feature section of this journal. Readers in England can get it directly from the author.

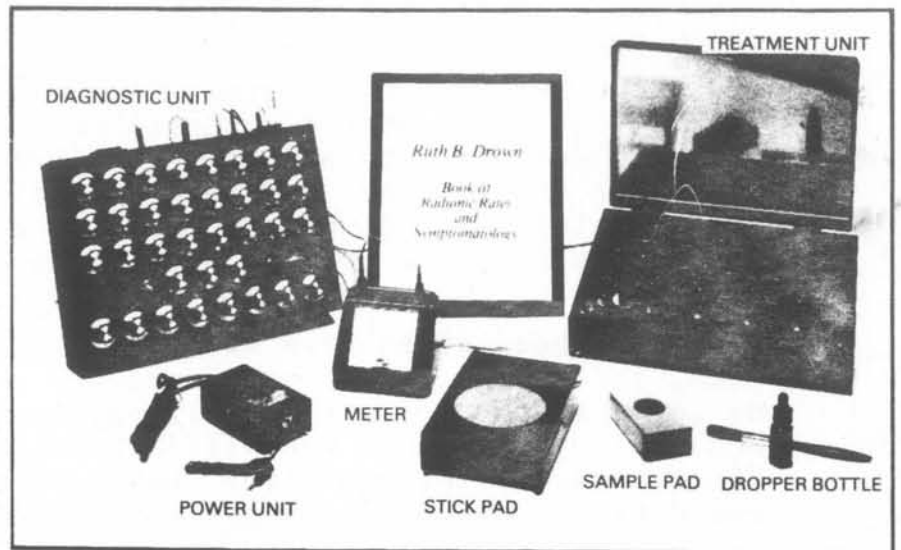

The 'LINK' Radionic System.

EAST OF TOMORROW

BSR Associate and good friend Maria Hardy has written her eighth book "East of Tomorrow". She has dedicated this book "To all who ever injured me, and thus taught me the joy of forgiving." We all can learn something from this good woman. She has had many jobs in her exciting 82 years and this book covers many of them along with her trial and error lessons in life. Maria has a Practitioner's degree from Religious Science and worked with the Cayce family at the A.R.E. in Virginia Beach. She has authored and lectured on color therapy and dream interpretation among her many credits.

Maria has also developed a hair conditioner that works wonders. Her beautiful head of hair bears testimony to its efficacy. Two of the other books she has authored are, "Color Can Change Your Life," and "Primer For Color Students. 'Grandma Hardy's Hair Stuff' and her three books mentioned here are available through BSRF Headquarters. "East of Tomorrow" is \$10, "Color Can Change Your Life" is \$2.50, "Primer for Color Students" is \$2 and the 'Hair Stuff' is \$20 a bottle. Please add postage (and Californians add tax).

COLOR CHANGED HER LIFE

"Aside from Faith, the study and practice of the effect of COLOR on my life is credited with most of my health and state of being as I now enter the eighty-third year of my life. The teaching and sharing of this knowledge constitutes a major part of my contribution to the well-being of others in this world.

"The two booklets, Primer for Color Students and Color can Change Your Life, that I authored have sold thousands of copies. The hundreds of lectures and interviews I have shared on the subject have opened doors and left a trail paved with blessings. It is a ministry and when God gave us the rainbow as a pledge, I think he meant it in many ways. I am still exploring and sharing the riches of that pledge and promise.

"In those seven rays of color, red, orange, yellow, green, blue, indigo and violet are found the vibrations that can warm or cool, soothe or agitate, lift or lower the spirits, thoughts and feelings of those who will attend and obey. My more recent "Self Analysis Through Color" has helped each participant understand him or herself in a new and unjudgemental manner.

"Again, I must express gratitude that I have been enabled to render this service to so many in such enjoyable ways." Maria Hardy from her latest book "East of Tomorrow."

SPECTRO-CHROME METRY CONTACTS

No Diagnosis * No Drugs * No Manipulation * No Surgery. These words are found in the three volume Spectro-Chrome Metry Encyclopedia by Dinshah P. Ghadiali. This compendium is one of the most complete and thorough books ever compiled on the usage of color for treating unbalanced conditions of the body.

For those of you who are unfamiliar with Dinshah's work turn to the article on Murray Denning's 'Truths' book where a brief introduction is given. For those of you who are familiar with the Spectro-Chrome System you will be happy to know that it is alive and well and still available. Since being here at Borderland I have come across two addresses where this information can be found.

Nick's Enterprises, 811 St. Louis, Ferndale MI 48220 is the publisher of The Ferndale News. Contained in that newspaper is a supplement titled 'Natural Living' by Sarosh Dinshah Ghadiali. Natural Living is a regular feature covering day to day use of God's spectrum in balancing our lives. The three volume Encyclopedia by Dinshah is available through Nick's along with "DINSHAH - Compendium of Light and Color for the New Age" by Sarosh, his Fifth Disciple (son). Several other related books are available and the Ferndale News is worth subscribing to for the supplement. Check this one out!

The Dinshah Health Society, 100 Dinshah Drive, Malaga NJ, 08328 is another good source of material on this subject. "The Spectro-Chrome System" by Darius Dinshah is published by them. This book is essential to those looking for modern color filters for work along these lines. The current Roscolene Filter numbers are given to achieve the proper tonation along Spectro-Chrome lines. Also available is the "Dinshah Cookbook" described as vegetarian cookery, in an unusual format designed for the beginner. Write for current prices. Read and learn of the wonders of God's rainbow and its effects on our lives.

BRIDGE TO INFINITY

As a service to our readers we are now carrying Bruce Cathie's latest book "The Bridge To Infinity - Harmonic 371244". This book is an update and refinement of his earlier three books on the harmonics of the earth grid system and the structure of our space time reality. This book is a must for the serious researcher in these areas.

Some of the Chapters include: The Harmonic Geometrics of the Earth; The Harmonics of the Great Pyramid; The Harmonics of Water, Temperature and Sound; Research into the Geometric Structure of Matter; The Secrets of Levitation; The Harmonics of Stonehenge; The Magnetic Motor and Stonehenge; The George Adamski Story - Fact or Fiction; The Harmonics of Destruction and Harmonics from Heaven. This book is available from Borderland for \$15.00 plus postage.

THE CAMERON AURAMETER

Borderland Sciences now carries copper Aurameter dowsing instruments as designed by Verne Cameron - Master Dowser. Meade Layne and Riley Crabb both contributed to our publication on Cameron and now we can supply you with an Aurameter for \$28.00 PP. I feel that this is a fair price - the other day we got a catalog from the east coast and it had Aurameters for \$49.95.

To support and expand the Foundation I am going to be carrying more publications and devices. Many of you have responded to various mailers that have been sent out and one that has had a lot of interest is the JLN-100.

EXPERIMENTAL ANTI-JET-LAG SYSTEM

This unit is an advancement in the field of ELF pulse devices. It contains an advanced antenna system that works as no other before it. In the March-April Journal there will be an article describing its function and building. We will provide you with a schematic and will probably have kits for do-it-yourselfers. The question most commonly asked is what frequencies does the JLN-MULTIPLEX have? It has 7.83 Hz - Earth Resonance; 9.26 R/L brain harmonizing; 10.5 Hz - Relaxed Focusing meditation and 14.0 Hz - an activity setting. Write for more details. This is the ELF unit of the Future!

IMPLOSION * Viktor Schauberger and the Path of Natural Energy

This is the revised edition of BSRF's book -IMPLOSION INSTEAD OF EXPLOSION. It now contains more information on the incredible Viktor Schauberger as published in the Journal of Borderland Research. Also included is information never before published.

This new edition covers in detail the natural solution to the energy problem through diamagnetism and etheric forces. Viktor Schauberger discovered the inherent energy in water and showed through his discoveries that our present technology is headed in the wrong direction. His discoveries hold the key to a life benefiting, non-polluting civilization. If only people could wake up and pay attention to the deep insight that Schauberger had. He truly grasped the planetary system of water flow. All that he predicted has come true today.

Our present technology is based on explosion forces - centrifugal force. This force creates stress, heat and pollution. Implosion technology, based on the natural rhythm of water, is the polar opposite of explosion. Centripetal technology cools down while running and creates a powerful diamagnetic force that can be tapped to serve all our present energy needs. This force actually cleans pollution from air and water while it runs.

Included in the book is an article from a 1953 issue of the "PENDULUM" (published in this issue of the journal) describing how to design you garden on these principles, with the result of healthy crops and beneficial results to nearby humans and animals. Discover for yourself the true power of nature!

IMPLOSION (BSRA #2-V).....\$7.50 plus P & H

-----CALIFORNIANS ADD 6% SALES TAX-----

The JOURNAL of
Borderland Research

Bulk Rate
U.S. POSTAGE
PAID
Vista, Calif.
Permit No. 42

A Publication of:
Borderland Sciences
Research Foundation
PO Box 549, Vista,
California USA
92083-0190